

# Residential Smart Inverter

## ES Uniq 3.0-6.0kW

- LX A5.0-10
- LX A5.0-30
- LX U5.0-30
- GW14.3-BAT-LV-G10

## Solutions Manual

## Copyright Statement

**Copyright©GoodWe Technologies Co., Ltd. 2025. All rights reserved.**

No part of this manual can be reproduced or transmitted to the public platform in any form or by any means without the prior written authorization of GoodWe Technologies Co., Ltd.

## **Trademarks**

**GOODWE** and other GOODWE trademarks are trademarks of GoodWe Technologies Co.,Ltd. All other trademarks or registered trademarks mentioned in this brochure are the property of their respective owners.

## **NOTICE**

The information in this user manual is subject to change due to product updates or other reasons.

This manual cannot replace the product safety labels unless otherwise specified. All descriptions in the manual are for guidance only.

## Table of Contents

1 About This Manual	14
1.1 Overview	14
1.2 Applicable Model	14
1.3 Symbol Definition	15
2 Safety Precautions	17
2.1 General Safety	17
2.2 Personal Requirements	17
2.3 System Safety	18
2.3.1 PV String Safety	19
2.3.2 Inverter Safety	19
2.3.3 Battery Safety	20
2.3.4 Smart Meter Safety	22
2.4 Safety Symbols and Certification Marks	22
2.5 EU Declaration of Conformity	24
2.5.1 Equipment with Wireless Communication Modules	24
2.5.2 Equipment without Wireless Communication Modules (Except Battery)	24
2.5.3 Battery	25
3 System Introduction	26
3.1 System Overview	26
3.2 Product Overview	37
3.2.1 Inverter	37

3.2.2 Battery	38
3.2.2.1 LX A5.0-10	38
3.2.2.2 LX A5.0-30	38
3.2.2.3 LX U5.0-30	39
3.2.2.4 GW14.3-BAT-LV-G10	39
3.2.3 Smart Meter	40
3.2.4 Smart Dongle	40
3.3 Supported Grid Types	41
3.4 System Working Mode	41
3.5 Features	51
4 Check and Storage	54
4.1 Check Before Receiving	54
4.2 Deliverables	54
4.2.1 Inverter Deliverables	54
4.2.2 Battery Deliverables	56
4.2.2.1 Battery Deliverables (LX A5.0-10)	56
4.2.2.2 Battery Deliverables (LX A5.0-30)	57
4.2.2.3 Battery Deliverables (LX U5.0-30)	58
4.2.2.4 Battery Deliverables (GW14.3- BAT-LV-G10)	60
4.2.3 Busbar Deliverables	61
4.2.3.1 BCB-11-WW-0	61
4.2.3.2 BCB-22-WW-0	61

4.2.3.3 BCB-32-WW-0	62
4.2.4 Smart Meter Deliverables	62
4.2.4.1 Smart Meter Deliverables (GMK110)	62
4.2.4.2 Smart Meter Deliverables (GM330)	63
4.2.5 Smart Dongle	63
4.2.5.1 Smart Dongle (WiFi/LAN Kit-20)	63
4.2.5.2 Smart Dongle (4G Kit-CN-G20 & 4G Kit-CN-G21)	63
4.2.5.3 Smart Dongle (Ezlink3000)	64
4.3 Storage	64
5 Installation	67
5.1 System Installation and Commissioning Procedure	67
5.2 Installation Requirements	67
5.2.1 Installation Environment Requirements	67
5.2.2 Installation Space Requirements	69
5.2.3 Tool Requirements	70
5.3 Equipment Handling	71
5.4 Installing the Inverter	73
5.5 Installing the Battery System	74
5.5.1 LX A5.0-30	80
5.5.2 LX A5.0-10	83
5.5.3 LX U5.0-30	85
5.5.4 GW14.3-BAT-LV-G10	86

5.6 Installing the Smart Meter.....	88
6 System Wirings.....	90
6.1 System Wiring Electrical Block Diagram.....	90
6.2 Detailed System Wiring Diagram.....	92
6.2.1 Detailed System Wiring Diagram for Single Inverter.....	92
6.2.2 Detailed System Wiring Diagram for Parallel System.....	94
6.3 Preparing Materials.....	96
6.3.1 Preparing Breakers.....	97
6.3.2 Preparing Cables.....	98
6.4 Connecting the PE Cable.....	102
6.5 Connecting the PV Cable.....	104
6.6 Connecting the Battery Cable.....	105
6.6.1 Connecting the Power Cable between the Inverter and Battery.....	123
6.6.2 Connecting the Communication Cable between the Inverter and Battery.....	128
6.7 Connecting the AC Cable.....	130
6.8 Connecting the Meter Cable.....	132
6.9 Connecting the Inverter Communication Cable.....	135
6.10 Installing the Battery Cover.....	139
6.10.1 LX A5.0-10.....	139
6.10.2 LX A5.0-30.....	140
6.10.3 LX U5.0-30.....	140

6.10.4 GW14.3-BAT-LV-G10	141
7 System Commissioning	142
7.1 Check Before Power ON	142
7.2 Power ON	142
7.3 Indicators	145
7.3.1 Inverter Indicators	145
7.3.2 Battery Indicators	146
7.3.2.1 LX A5.0-10	146
7.3.2.2 LX A5.0-30, LX U5.0-30	148
7.3.2.3 GW14.3-BAT-LV-G10	148
7.3.3 Smart Meter Indicator	151
7.3.3.1 GMK110	151
7.3.3.2 GM330	151
7.3.4 Smart Dongle Indicator	152
7.3.4.1 WiFi/LAN Kit-20	152
7.3.4.2 4G Kit-CN-G20 & 4G Kit-CN-G21	153
7.3.4.3 Ezlink3000	154
8 Rapid System Configuration	155
8.1 Downloading the App	155
8.1.1 Downloading SolarGo App	155
8.1.2 Downloading SEMS+ APP	155
8.2 Connecting the inverter via SolarGo	156

8.3 Setting Communication Parameters.....	157
8.3.1 Setting Privacy and Security Parameters.....	158
8.3.2 Setting WLAN/LAN Parameters.....	161
8.3.3 Setting APN Parameters.....	163
8.3.4 Setting RS485 Communication Parameters.....	164
8.4 Quick System Setup.....	165
8.4.1 Quick System Setup (Type III).....	166
8.5 Power Plant Creation.....	171
9 System Commissioning.....	173
9.1 Commissioning Method Overview.....	173
9.2 Configuration via LCD.....	173
9.2.1 LCD Overview.....	173
9.2.2 Quick Settings.....	175
9.2.3 Setting Advanced Parameters.....	181
9.2.4 Setting Immediate Charging.....	182
9.2.5 Setting the Basic Information.....	183
9.2.6 Viewing Device Information.....	183
9.2.7 Setting Port Connection.....	184
9.3 Configuration via SolarGo APP.....	188
9.3.1 App Introduction.....	188
9.3.1.1 Downloading and Installing the App.....	188
9.3.1.2 Connection Method.....	189



9.3.1.3 Introduction of Interface.....	190
9.3.2 Connecting the Energy Storage Inverter.....	191
9.3.2.1 Connecting the Energy Storage Inverter (Bluetooth).....	192
9.3.3 Introduction of the Energy Storage Inverter Interface.....	193
9.3.4 Setting Communication Parameters.....	195
9.3.4.1 Setting Privacy and Security Parameters.....	195
9.3.4.2 Setting WLAN/LAN Parameters.....	198
9.3.4.3 Setting APN Parameters.....	200
9.3.4.4 Setting RS485 Communication Parameters.....	201
9.3.5 Quick System Setup.....	202
9.3.5.1 Quick System Setup (Type III).....	203
9.3.6 Setting the Basic Information.....	208
9.3.6.1 Setting up Lightning Protection Alarm Function.....	208
9.3.6.2 Setting up Shadow Scanning Function.....	209
9.3.6.3 Setting Backup Power Parameters.....	210
9.3.7 Setting Advanced Parameters.....	212
9.3.7.1 Setting DRED/Remote Shutdown/RCR/EnWG 14a Function.....	212
9.3.7.2 Setting BACK-UP N and PE Relay Switches.....	213
9.3.7.3 Setting the On-Grid Power Limit.....	214
9.3.7.3.1 Setting the On-Grid Power Limit (General).....	214
9.3.7.3.2 Setting the On-Grid Power Limit (Australia).....	215
9.3.7.4 Setting the Arc Detection Function.....	217

9.3.7.5 Set Battery Function.....	217
9.3.7.5.1 Set Parameters for Lithium Battery.....	217
9.3.7.5.2 Setting Lead-acid Battery Parameter.....	221
9.3.7.6 Setting PV Connect Mode.....	225
9.3.8 Setting Customized Safety Parameters.....	226
9.3.8.1 Setting Reactive Curve.....	227
9.3.8.2 Setting Active Curve.....	231
9.3.8.3 Setting Grid Protection Parameters.....	237
9.3.8.4 Setting Grid Connection Parameters.....	238
9.3.8.5 Setting Voltage Fault Ride through Parameters.....	240
9.3.8.6 Setting Frequency Fault Ride through Parameters.....	241
9.3.9 Setting Generator/Load Control Parameters.....	242
9.3.9.1 Setting Load Control Parameters.....	242
9.3.9.2 Setting Generator Parameters.....	244
9.3.9.3 Setting Microgrid Parameters.....	247
9.3.10 Setting Smart Meter Parameters.....	249
9.3.10.1 Meter/CT Assisted Test.....	249
9.3.11 Equipment Maintenance.....	250
9.3.11.1 View Firmware Information/Firmware Upgrade.....	250
9.3.11.1.1 Regular Firmware Upgrades.....	250
9.3.11.1.2 One-click Firmware Upgrade.....	251
9.3.11.1.3 Automatic Firmware Upgrade.....	252

9.3.11.2 Changing Login Password.....	253
10 Power Plant Monitoring.....	255
10.1 SEMS+.....	255
10.1.1 App Introduction.....	255
10.1.1.1 Complementary Products.....	255
10.1.1.2 Downloading and Installing the App.....	255
10.1.1.3 Connection Method.....	256
10.1.1.4 Setting Language and Server.....	256
10.1.1.5 Setting Communication Parameters.....	257
10.1.2 Account Management.....	257
10.1.2.1 Registering.....	257
10.1.2.2 Account Login.....	258
10.1.2.3 Switch.....	259
10.1.2.4 Canceling.....	259
10.1.2.5 Account Permissions.....	260
10.1.3 Viewing Power Plant Information.....	264
10.1.3.1 View All Power Plant Overview Information.....	264
10.1.3.2 Viewing Monopower Plant Details.....	266
10.1.3.2.1 Viewing Power Plant Details (Traditional Mode).....	267
10.1.4 Viewing Alarm Information.....	269
10.1.4.1 Viewing Alarm Information for All Power Plants.....	269
10.1.4.2 Viewing the current power plant's alarm information.....	269

10.1.4.2.1 Viewing Alarm Information for the Current Power Plant (Traditional Mode)	270
10.1.4.3 Viewing the Current Device’s Alarm Information	270
10.1.5 Viewing Power Plant Report Information	271
10.1.6 Power Plant Management	273
10.1.6.1 Power Plant Creation	273
10.1.6.2 Configuring Power Plant Information	274
10.1.6.3 Power Plant Visitors Management	275
10.1.6.4 Power Plant Photos Management	276
10.1.6.5 Setting PV Component Layout	277
10.1.6.6 Adjusting the Information Displayed on the Power Station Details Page	278
10.1.6.7 Deleting Power Plant	279
10.1.6.8 Collecting Power Plant	280
10.1.7 Managing the Equipment in the Power Plant	281
10.1.7.1 Additional Equipment	281
10.1.7.2 Editing Device Information	282
10.1.7.3 Deleting Device	283
10.1.7.4 Upgrading Device Firmware Version	284
10.1.8 Remote Management Device	285
10.1.8.1 Setting Energy Storage Inverter Parameters	286
11 Maintenance	292
11.1 Power Off the System	292
11.2 Removing the Equipment	293

11.3 Disposing of the Equipment	293
11.4 Routine Maintenance	293
11.5 Fault	295
11.5.1 Viewing Fault/Alarms Information	295
11.5.2 Fault Information and Troubleshooting	295
11.5.2.1 System Failure	296
11.5.2.2 Inverter Troubleshooting	298
11.5.2.3 Battery Fault (LX A5.0-10)	341
11.5.2.4 Battery Fault (LX A5.0-30, LX U5.0-30)	343
11.5.2.5 Battery Fault (GW14.3-BAT-LV-G10)	346
11.5.3 Operation After Fault Clearance	349
11.5.3.1 Clear AFCI Alarm	349
12 Technical Parameters	351
12.1 Inverter Parameters	351
12.2 Battery Technical Data	361
12.2.1 LX A5.0-10	361
12.2.2 LX A5.0-30	362
12.2.3 LX U5.0-30	364
12.2.4 GW14.3-BAT-LV-G10	366
12.3 Smart Meter Technical Data	368
12.3.1 GMK110	368
12.3.2 GM330	368

12.4 Smart Dongle Technical Data	369
12.4.1 WiFi/LAN Kit-20	370
12.4.2 4G Kit-CN-G20, 4G Kit-CN-G21	370
12.4.3 Ezlink3000	371
13 Appendix	372
13.1 FAQ	372
13.1.1 How to Conduct Auxiliary Detection for Smart Meters/CT?	372
13.1.2 How to Upgrade the Device Version	372
13.2 Abbreviations	373
13.3 Explanation of Terms	376
13.4 Meaning of Battery SN Code	377
14 Contact Details	379

# 1 About This Manual

## 1.1 Overview

The energy storage system consists of inverter, battery system, and smart meter. This manual describes the product information, installation, electrical connection, commissioning, troubleshooting and maintenance of the system. Read through this manual before installing and operating the products to understand product safety information and familiarize yourself with functions and features of the product. This manual is subject to update without notice. For more product details and latest documents, visit <https://en.goodwe.com/>.

## 1.2 Applicable Model

The energy storage system consists the following products:

Product type	Product information	Description
Inverter	GW3000-ES-C10	Nominal output power: 3.0kW
	GW3000-ES-C11	
	GW3600-ES-C10	Nominal output power: 3.0kW
	GW5000-ES-C10	Nominal output power: 3.0kW
	GW6000-ES-C10	Nominal output power: 3.0kW
Battery System	LX A5.0-10	Usable energy of 5.0kWh, supports a maximum of 15 batteries connected in parallel.
	LX A5.0-30	Usable energy of 5.12kWh, supports a maximum of 30 batteries connected in parallel.
	LX U5.0-30	Usable energy of 5.12kWh, supports a maximum of 30 batteries connected in parallel.
	GW14.3-BAT-LV-G10	Usable energy of 14.3kWh, supports a maximum of 16 batteries connected in parallel.

Product type	Product information	Description
Smart Meter	GMK110	It is a monitoring module in the energy storage system which can detect information such as operating voltage, current, and other data in the system.
	GM330	
Smart Dongle	WiFi/LAN Kit-20	In the single inverter scenario, the system operation information can be uploaded to a monitoring platform through WiFi or LAN signals.
	4G Kit-CN-G20 4G Kit-CN-G21	In the single inverter scenario, the system operation information can be uploaded to a monitoring platform through 4G signal.
	Ezlink3000	In parallel system with multi inverters, it is installed on the master inverter to upload the system running information to monitoring platform through WiFi or LAN signals.

### 1.3 Symbol Definition

<b>DANGER</b>
Indicates a high-level hazard that, if not avoided, will result in death or serious injury.
 <b>WARNING</b>
Indicates a medium-level hazard that, if not avoided, could result in death or serious injury.
<b>CAUTION</b>
Indicates a low-level hazard that, if not avoided, could result in minor or moderate injury.



## NOTICE

Highlights key information and supplements the texts. Or some skills and methods to solve product-related problems to save time.

## 2 Safety Precautions

Please strictly follow these safety instructions in the user manual during the operation.

### WARNING

The products are designed and tested strictly to comply with related safety rules. Follow all the safety instructions and cautions before any operations. Improper operation might cause personal injury or property damage as the products are electrical equipment.

### 2.1 General Safety

#### NOTICE

- The information in this user manual is subject to change due to product updates or other reasons. This manual cannot replace the product safety labels unless otherwise specified. All descriptions in the manual are for guidance only.
- Before installations, read through the user manual to learn about the product and the precautions.
- All operations should be performed by trained and knowledgeable technicians who are familiar with local standards and safety regulations.
- Use insulating tools and wear personal protective equipment(PPE) when operating the equipment to ensure personal safety. Wear anti-static gloves, wrist strips, and cloths when touching electronic devices to protect the equipment from damage.
- Unauthorized dismantling or modification may damage the equipment, and the damage is not covered under the warranty.
- Strictly follow the installation, operation, and configuration instructions in this manual or the user manual. The manufacturer shall not be liable for equipment damage or personal injury if you do not follow the instructions. For more warranty details, please visit <https://www.goodwe.com/warrantyrelated.html>.

### 2.2 Personal Requirements

## NOTICE

- Personnel who install or maintain the equipment must be strictly trained, learn about safety precautions and correct operations.
- Only qualified professionals or trained personnel are allowed to install, operate, maintain, and replace the equipment or parts.

## 2.3 System Safety

### DANGER

- Disconnect the upstream switches to power off the equipment before any electrical connections. Do not work with power on. Otherwise, an electric shock may occur.
- Install a breaker at the voltage input side of the equipment to prevent personal injury or equipment damage caused by energized electrical work.
- All operations such as transportation, storage, installation, use and maintenance shall comply with applicable laws, regulations, standards and specifications.
- Perform electrical connections in compliance with local laws, regulations, standards and specifications, including cables and component specifications.
- Use the connectors included in the package to connect cables. The manufacturer shall not be liable for the equipment damage if connectors of other models are used.
- Ensure all cables are connected correctly, tightly, and securely. Inappropriate wiring may cause poor connection and damage the equipment.
- The PE cables must be connected and secured properly.
- To protect the equipment and components from damage during transportation, ensure that the transportation personnel are professionally trained. All operations during the transportation have to be recorded. The equipment shall be kept in balance to avoid falling down.
- The equipment is heavy. Please equip the corresponding personnel according to its weight, so that the equipment does not exceed the maximum weight that the personnel can carry to avoid personnel injuries.
- Keep the equipment stable to avoid dumping, which can result in equipment damage and personal injuries.

 WARNING

- Do not apply mechanical load to terminals, otherwise the terminals may be damaged.
- If the cable bears too much tension, the connection may be poor. Reserve a certain length of the cable before connecting it to corresponding ports.
- Tie the cables of the same type together, and place cables of different types at least 30mm apart. Do not place the cables entangled or crossed.
- Place the cables at least 30mm away from the heating components or heat sources, otherwise the insulation layer of the cables may be aging or broken due to high temperature.

### 2.3.1 PV String Safety

 WARNING

- Ensure the PV module frames and the bracket system are securely grounded.
- Ensure the DC cables are connected tightly, securely and correctly. Inappropriate wiring may cause poor contacts or high impedances, and damage the inverter.
- Measure the positive and negative terminals of the DC cable using a multimeter to avoid reverse polarity connection. Also, the voltage should be within the permissible range.
- Measure the DC cable using the multimeter to avoid reverse polarity connection. Also, the voltage should be under the max DC input voltage. The manufacturer shall not be liable for the damage caused by reverse connection and extremely high voltage.
- The PV strings cannot be grounded. Ensure the minimum insulation resistance of PV string to the ground meets the minimum insulation resistance requirements before connecting the PV string to the inverter ( $R = \text{maximum input voltage (V)} / 30\text{mA}$ ).
- Do not connect the same PV string to multiple inverters at the same time. Otherwise, the inverters may be damaged.
- PV modules used with inverters must comply with IEC 61730 Class A standard.

### 2.3.2 Inverter Safety

## WARNING

- The voltage and frequency at the connecting point should meet the on-grid requirements.
- Additional protective devices like circuit breakers or fuses are recommended on the AC side. Specification of the protective device should be at least 1.25 times the maximum AC output current.
- The arc fault alarms will be cleared automatically if the alarms are triggered less than 5 times in 24 hours. The inverter will shutdown for protection after the 5th electric arc fault. The inverter can operate normally after the fault is solved.
- BACK-UP is not recommended if the PV system is not configured with batteries. Otherwise, there may be a risk of system power outage.

### 2.3.3 Battery Safety

## DANGER

- Keep Power Off before any operations to avoid danger of electric shock. Strictly follow all safety precautions outlined in this manual and safety labels on the equipment during the operation.
- Do not disassemble, modify, or replace any part of the battery or the power control unit without official authorization from the manufacturer. Otherwise, it will cause electrical shock or damages to the equipment, which shall not be borne by the manufacturer.
- Do not hit, pull, drag, squeeze or step on the equipment or put the battery into fire. Otherwise, the battery may explode.
- Do not place the battery in a high temperature environment. Make sure that there is no direct sunlight and no heat source near the battery. When the ambient temperature exceeds 60 °C, it will cause fire.
- Do not use the battery or the power control unit if it is defective, broken, or damaged. Damaged battery may leak electrolyte.
- Do not move the battery system while it is working. Contact after-sales service if the battery shall be replaced or added.
- A short circuit in the battery may cause personal injury. The instantaneous high current caused by a short circuit can release a large amount of energy and may cause a fire.

 WARNING

- Factors such as temperature, humidity, weather conditions, etc. may limit the battery's current and affect its load.
- Contact after-sale service immediately if the battery is not able to be started. Otherwise, the battery might be damaged permanently.
- Inspect and maintain the battery regularly according to the maintenance requirements of the battery.

### Emergency Measures

- Battery Electrolyte Leakage

If the battery module leaks electrolyte, avoid contact with the leaking liquid or gas. The electrolyte is corrosive. It will cause skin irritation or chemical burn to the operator. Anyone contact the leaked substance accidentally has to act/respond as following:

- Breath in the leaked substance: Evacuate from the polluted area, and seek immediate medical assistance.
  - Eye contact: Rinse your eyes for at least 15 minutes with clean water and seek immediate medical assistance.
  - Skin contact: Thoroughly wash the touch area with soap and clean water, and seek immediate medical assistance.
  - Ingestion: Induce vomiting, and seek immediate medical assistance.
- Fire
    - The battery may burn when the ambient temperature exceeds 150°C. Poisonous and hazardous gas may be released if the battery is on fire.
    - In the event of a fire, please make sure that the carbon dioxide extinguisher or Novec1230 or FM-200 is nearby.
    - The fire cannot be put out by ABC dry powder extinguisher. Firefighters are required to wear full protective clothing and self-contained breathing apparatus.
  - Battery triggers fire protection

For batteries with fire protection functions, perform the following operations after the fire protection function is triggered:

    - Immediately cut off the main power switch to ensure that no current passes through the battery system.
    - Conduct a preliminary inspection of the appearance of the battery to determine if there is any damage, deformation, leakage, or odor. Check the battery casing,

connectors, and cables.

- Use temperature sensors to detect the temperature of the battery and its environment, ensuring there is no risk of overheating.
- Isolate and label damaged batteries, and handle them properly in accordance with local regulations.

### 2.3.4 Smart Meter Safety



#### WARNING











If the voltage of the power grid fluctuates, resulting in the voltage over 265V. In this case, long-term overvoltage operation may cause damage to the meter. It is recommended to add a fuse with a rated current of 0.5A on the voltage input side of the meter to protect it.

## 2.4 Safety Symbols and Certification Marks





#### DANGER

- All labels and warning marks should be visible after the installation. Do not cover, scrawl, or damage any label on the equipment.
- The following descriptions are for reference only. Please refer to the actual labeling of the equipment.

No.	Symbol	Descriptions
1		Potential risks exist. Wear proper PPE before any operations.
2		HIGH VOLTAGE HAZARD. High voltage exists. Disconnect all incoming power and turn off the product before working on it.
3		High-temperature hazard. Do not touch the product under operation to avoid being burnt.

No.	Symbol	Descriptions
4		Operate the equipment properly to avoid explosion.
5		Batteries contain flammable materials, beware of fire.
6		The equipment contains corrosive electrolytes. In case of a leak in the equipment, avoid contacting the leaked liquid or gas.
7		Delayed discharge. Wait 5 minutes after power off until the components are completely discharged.
8		Install the equipment away from fire sources.
9		Keep away from children.
10		Do not pour with water.
11		Read through the user manual before any operations.
12		Wear PPE during installation, operation and maintaining.
13		Do not dispose of the System as household waste. Deal with it in compliance with local laws and regulations, or send it back to the manufacturer.
14		Grounding point.



No.	Symbol	Descriptions
15		Recycle regeneration mark.
16		CE Mark.
17		TUV mark.
18		RCM mark.

## 2.5 EU Declaration of Conformity

### 2.5.1 Equipment with Wireless Communication Modules

The equipment with wireless communication modules sold in the European market meets the requirements of the following directives:

- Radio Equipment Directive 2014/53/EU (RED)
- Restrictions of Hazardous Substances Directive 2011/65/EU and (EU) 2015/863 (RoHS)
- Waste Electrical and Electronic Equipment 2012/19/EU
- Registration, Evaluation, Authorization and Restriction of Chemicals (EC) No 1907/2006 (REACH)

### 2.5.2 Equipment without Wireless Communication Modules (Except Battery)

The equipment without wireless communication modules sold in the European market meets the requirements of the following directives:

- Electromagnetic compatibility Directive 2014/30/EU (EMC)
- Electrical Apparatus Low Voltage Directive 2014/35/EU (LVD)
- Restrictions of Hazardous Substances Directive 2011/65/EU and (EU) 2015/863 (RoHS)

- Waste Electrical and Electronic Equipment 2012/19/EU
- Registration, Evaluation, Authorization and Restriction of Chemicals (EC) No 1907/2006 (REACH)

### **2.5.3 Battery**

The batteries sold in the European market meets the requirements of the following directives:

- Electromagnetic compatibility Directive 2014/30/EU (EMC)
- Electrical Apparatus Low Voltage Directive 2014/35/EU (LVD)
- Battery Directive 2006/66/EC and Amending Directive 2013/56/EU
- Waste Electrical and Electronic Equipment 2012/19/EU
- Registration, Evaluation, Authorization and Restriction of Chemicals (EC) No 1907/2006 (REACH)

You can download the EU Declaration of Conformity from our [official website](#).

## 3 System Introduction

### 3.1 System Overview

The residential smart inverter solution consists of inverter, battery system, smart meter, smart dongle, etc. In the PV system, solar energy can be converted to electric energy for household needs. The IoT devices in the system control the electrical equipment by recognizing the overall power consumption situation. So that the power will be managed in a smart way, deciding whether the power is to be used by the loads, stored in batteries, or exported to the grid, etc.

#### WARNING

- Select the battery model according to the inverter model and the approved battery list. For battery requirements used in the same system, such as whether the models can be mixed and matched, and whether the capacities are consistent, please refer to the corresponding model's battery user manual or contact the battery manufacturer for relevant requirements. Battery Compatibility Overview:  
[https://.goodwe.com/Ftp/EN/Downloads/User%20Manual/GW\\_Battery%20Compatibility%20Overview-EN.pdf](https://.goodwe.com/Ftp/EN/Downloads/User%20Manual/GW_Battery%20Compatibility%20Overview-EN.pdf)
- Due to product upgrades or other reasons, the document content may be updated irregularly. The matching relationship between inverters and IoT products can refer to:  
[https://.goodwe.com/Ftp/EN/Downloads/User%20Manual/GW\\_Compatibility-list-of-GoodWe-inverters-and-IoT-products-EN.pdf](https://.goodwe.com/Ftp/EN/Downloads/User%20Manual/GW_Compatibility-list-of-GoodWe-inverters-and-IoT-products-EN.pdf)
- For the detailed network configuration and wiring schemes for various scenarios, please refer to: [6.2.System Wiring Detail Diagram\(Page 92\)](#).

#### Off-Grid Load-Carrying Capacity of Inverter Description

Load Type	GW3000-ES-C10 GW3000-ES-C11 GW3600-ES-C10	GW5000-ES-C10 GW6000-ES-C10
Rated Power of Single Generator Load (kVA)	0.55	1.1

### Off-Grid Load-Carrying Capacity of Inverter Description

Total Rated Power of Generator Loads (kVA)	$0.75 * P_n$	$0.75 * P_n$
Capacitive Load (kVA)	$0.33 * P_n$	$0.33 * P_n$
Half-wave load(kW)	$0.5 * P_n$	$0.5 * P_n$

Note:

- $P_n$ : Rated Output Power of the inverter.
- If the rated power of a single generator load is greater than or equal to the nominal value in the above table, a VFD/VSD shall be configured;
- For 2 or more units operating in parallel, the allowable total generator load power = Single generator load nominal power \* Number of parallel units \* 80%.

### General Scenario

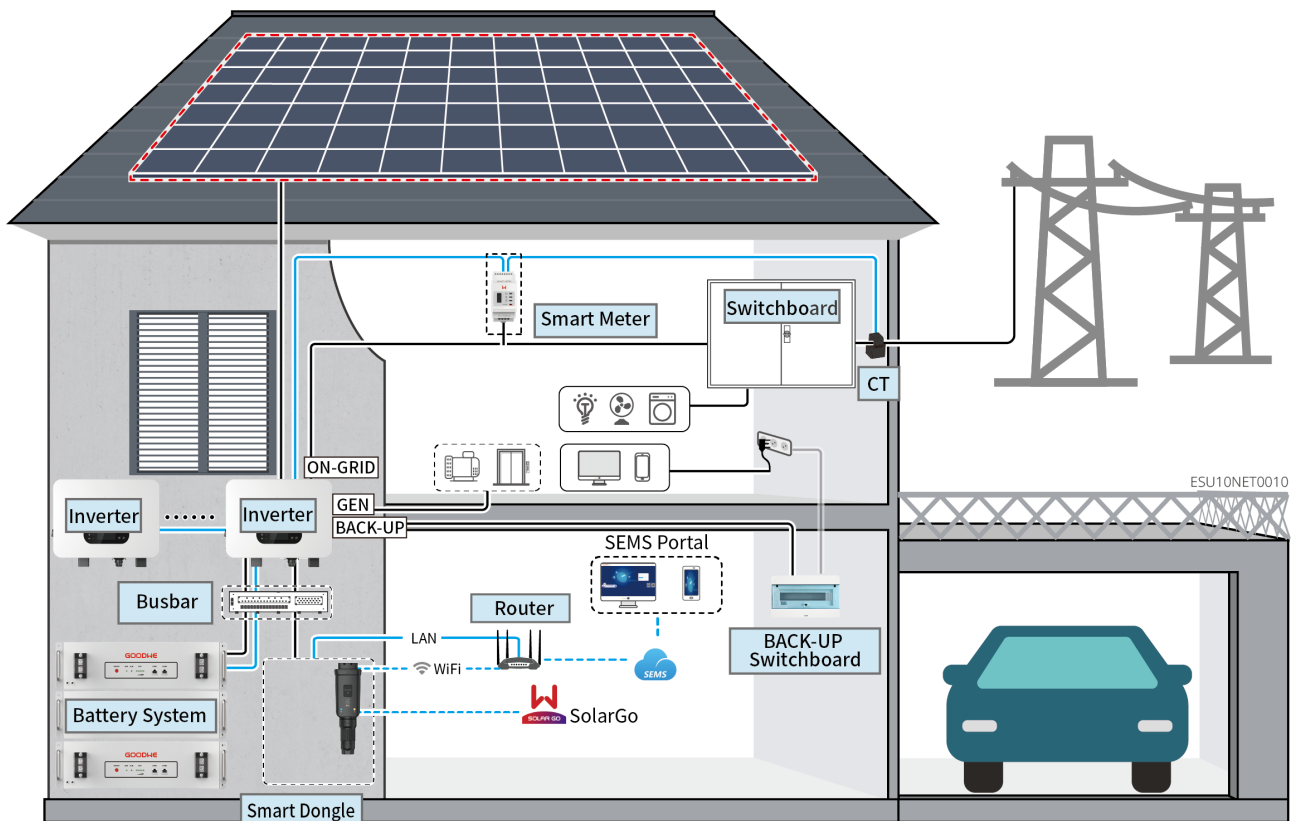



Product Type	Model	Description
	LX U5.0-30	The nominal charging current of a single battery is 60A; and the nominal discharging current is 100A; the maximum charging current is 90A; the maximum discharging current is 100A. A maximum of 30 batteries can be connected in parallel in one system.
	GW14.3-BAT-LV-G10	The rated charge/discharge current for a single battery is 140A; the maximum charge current is 224A; the maximum discharge current is 260A, and the system supports up to 15 batteries in parallel.
	Lead Acid Battery	<ul style="list-style-type: none"> <li>• Supports connection to lead-acid batteries of AGM, GEL, and Flooded types.</li> <li>• The number of batteries that can be connected in series is calculated based on the voltage of lead-acid batteries, and the total voltage of batteries connected in series is not allowed to exceed 60V.</li> </ul>
Busbar	BCB-11-WW-0 BCB-22-WW-0 BCB-32-WW-0 BCB-33-WW-0 (Purchase from GoodWe)	<p>Please select the busbar according to the charging/discharging capacity of the inverter, the load size, and the charging/discharging capacity of the battery in the system.</p> <ul style="list-style-type: none"> <li>• BCB-11-WW-0:               <ul style="list-style-type: none"> <li>◦ Used with LX A5.0-10, the battery system supports a maximum working current of 360A, working power of 18kW, and can connect to a maximum of 3 inverters, and 6 batteries.</li> </ul> </li> <li>• BCB-22-WW-0:               <ul style="list-style-type: none"> <li>◦ Used with LX A5.0-10, the battery system supports a maximum working current of 720A, working power of 36kW, and can connect to a maximum of 6 inverters, and 12 batteries..</li> <li>◦ Used with LX A5.0-30, the battery system supports a maximum working current of 720A, working power of 36kW, and can connect to a maximum of 6 inverters, and 6 batteries.</li> </ul> </li> </ul>

Product Type	Model	Description
		<ul style="list-style-type: none"> <li>◦ Used with LX U5.0-30, the battery system supports a maximum working current of 720A, working power of 36kW, and can connect to a maximum of 6 inverters, and 6 batteries.</li> <li>• BCB-32-WW-0: <ul style="list-style-type: none"> <li>◦ Used with LX A5.0-10, the battery system supports a maximum working current of 720A, working power of 36kW, and can connect to a maximum of 6 inverters, and 15 batteries..</li> <li>◦ Used with LX A5.0-30, the battery system supports a maximum working current of 720A, working power of 36kW, and can connect to a maximum of 6 inverters, and 15 batteries..</li> <li>◦ Used with LX U5.0-30, the battery system supports a maximum working current of 720A, working power of 36kW, and can connect to a maximum of 6 inverters, and 6 batteries.</li> <li>◦ Used with GW14.3- BAT-LV-G10, the battery system supports a maximum working current of 720A, working power of 36kW, and can connect to a maximum of 6 inverters, and 15 batteries.</li> </ul> </li> <li>• BCB-33-WW-0: <ul style="list-style-type: none"> <li>◦ Used with LX U5.0-30, the battery system supports a maximum working current of 720A, working power of 36kW, and can connect to a maximum of 6 inverters, and 15 batteries.. When the number of batteries exceeds 8, two 600A fuses need to be connected in parallel..</li> </ul> </li> <li>• Others: Please prepare busbar based on actual system power and current.</li> </ul>

Product Type	Model	Description
Smart Meter	<ul style="list-style-type: none"> <li>• Built-in Smart Meter (Standard)</li> <li>• GMK110 (purchase from GoodWe)</li> <li>• GM330 (purchase from GoodWe)</li> </ul>	<ul style="list-style-type: none"> <li>• Built-in smart meter: When the number of parallel inverters <math>\leq 2</math> and the CT cable length <math>\leq 10</math> meters, the built-in smart meter can be used. Built-in smart meter: 10-meter wire CT, default CT ratio: 120A/40mA.</li> <li>• GMK110: When the length of the inverter's built-in CT cable is insufficient to reach the distribution panel, an external GMK110 electricity meter can be used for extension. It is not supported to change the CT to other type, CT ratio: 120A/40mA.</li> <li>• GM330: Supports purchasing from GOODWE or third-party, CT ratio requirement: nA/5A</li> <li>• nA: CT Primary side input current, the range of n is 200-5000</li> <li>• 5A: CT Secondary side output voltage.</li> </ul>
Communication Module	<ul style="list-style-type: none"> <li>• WiFi/LAN Kit-20 (Standard)</li> <li>• 4G Kit- CN-G20 (Only for China)</li> <li>• 4G Kit- CN-G21 (Only for China)</li> <li>• Ezlink3000 (purchase from GoodWe)</li> </ul>	<ul style="list-style-type: none"> <li>• For a single inverter unit, use the WiFi/LAN Kit-20, 4G Kit-CN-G20, or 4G Kit-CN-G21 module.</li> <li>• In parallel system, only master inverter needs to be connected to Ezlink3000, and slave inverter does not need to be connected to communication module. Ezlink3000 firmware version is 05 or above.</li> </ul>



Product Type	Model	Description
Heavy Load	-	<p>SG Ready is supported, and specifications for large loads are as follow:</p> <ol style="list-style-type: none"> <li>1. Large load total power &lt; GEN port maximum output power</li> <li>2. The specifications for large loads are as follows: Large load power + BACK-UP power &lt; AC maximum input power (grid)</li> </ol>
Generator	-	Generator rated voltage meets inverter GEN port rated voltage.

### Microgrid Scenario

**WARNING**

- In microgrid scenarios, the PV open-circuit voltage of the PV storage hybrid inverter is recommended to be < 0.85\*PV maximum input voltage to prevent the system voltage from becoming too high and triggering overvoltage protection under adverse conditions.
- In the microgrid system, parallelization is not supported by the inverter, and only a single inverter can be supported to use in the system..
- If the system is in a high temperature or BMS current limiting situation, it may cause the battery charging power to be limited, which may lead to high system voltage triggering over-voltage protection.
- In microgrid scenarios, make sure that the overfrequency derating point of the on-grid inverter is the same as that of the hybrid inverter.
- Make sure that the overfrequency derating curve of the on-grid inverter is set according to the following via SolarGo:
  - Set the end power to 0% Pn
  - Set the quiet time to 0
  - Set the power response mode to Off.

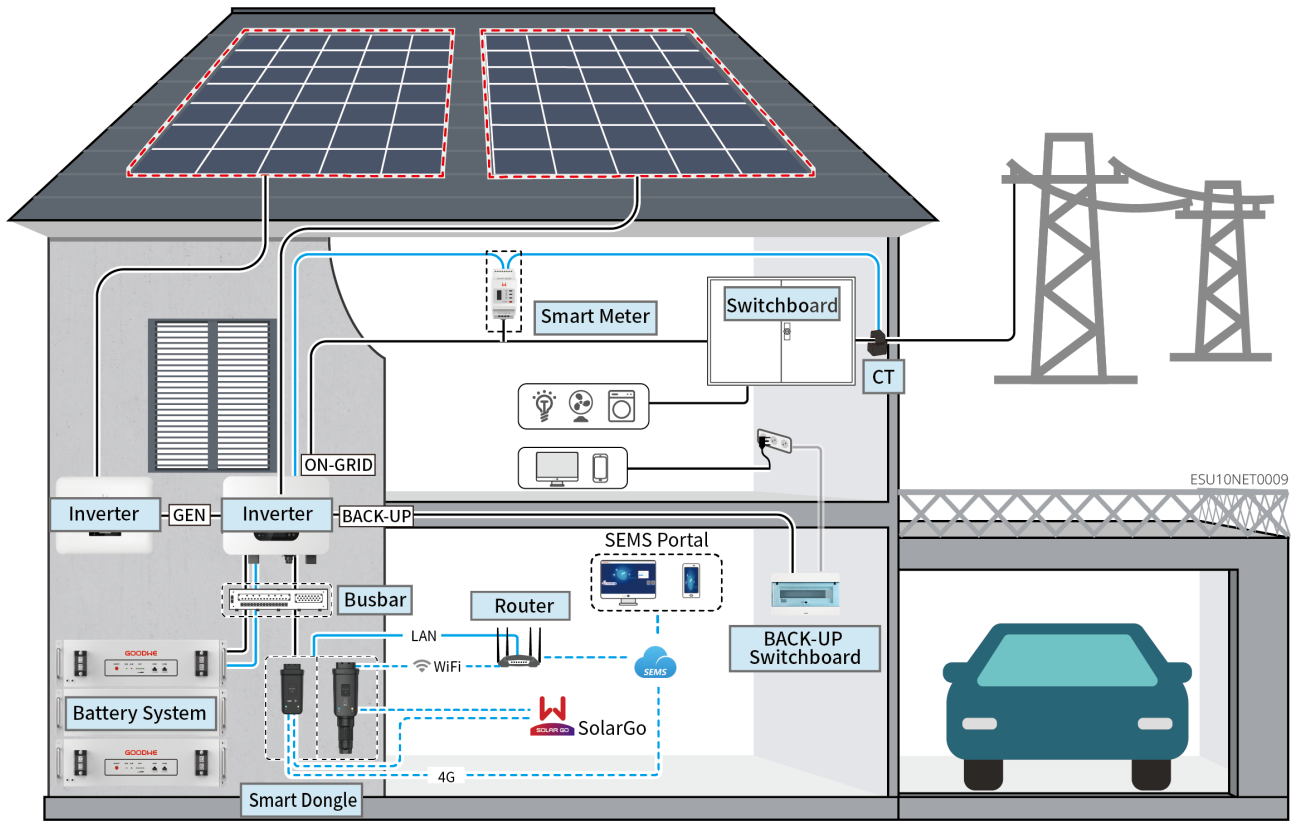

Product Type	Model	Description
Hybrid Inverter	GW3000-ES-C10	<ul style="list-style-type: none"> <li>In the microgrid system, parallelization is not supported by the inverter, and only a single inverter can be supported to use in the system.</li> <li>Inverter               <ul style="list-style-type: none"> <li>The ARM software version of the inverter is 12.451 and above.</li> <li>The DSP software version of the inverter is 0.1313 and above.</li> </ul> </li> <li>To be compatible with the GW14.3-BAT-LV-G10 battery, the following version requirements must be met:               <ul style="list-style-type: none"> <li>The ARM software version of the inverter is 14.470 and above.</li> <li>The DSP software version of the inverter is 1.408 and above.</li> </ul> </li> </ul>
	GW3000-ES-C11	
	GW3600-ES-C10	
	GW5000-ES-C10	
	GW6000-ES-C10	
	LX A5.0-10	

Product Type	Model	Description
Battery system	LX A5.0-30	<p>Battery of different models cannot be mixed.</p> <ul style="list-style-type: none"> <li>LX A5.0-10: The nominal charging and discharging current of a single battery is 60A; a maximum of 15 batteries can be connected in parallel in one system.</li> <li>LX A5.0-30: The nominal charging current of a single battery is 60A, and the discharging current is 100A; the maximum charging current is 90A; the maximum discharging current is 100A. a maximum of 30 batteries can be connected in parallel in one system.</li> </ul>
	LX U5.0-30	The nominal charging current of a single battery is 60A; and the nominal discharging current is 100A; the maximum charging current is 90A; the maximum discharging current is 100A. A maximum of 30 batteries can be connected in parallel in one system.
	GW14.3-BAT-LV-G10	The rated charge/discharge current for a single battery is 140A; the maximum charge current is 224A; the maximum discharge current is 260A, and the system supports up to 16 batteries in parallel.
	Lead Acid Battery	<ul style="list-style-type: none"> <li>Supports connection to lead-acid batteries of AGM, GEL, and Flooded types.</li> <li>The number of batteries that can be connected in series is calculated based on the voltage of lead-acid batteries, and the total voltage of batteries connected in series is not allowed to exceed 60V.</li> </ul>
Busbar	BCB-11-WW-0 BCB-22-WW-0 BCB-32-WW-0 BCB-33-WW-0 (Purchase from GoodWe)	<p>Please select the busbar according to the charging/discharging capacity of the inverter, the load size, and the charging/discharging capacity of the battery in the system.</p> <ul style="list-style-type: none"> <li>BCB-11-WW-0:</li> </ul>

Product Type	Model	Description
		<ul style="list-style-type: none"> <li>◦ Used with LX A5.0-10, the battery system supports a maximum working current of 360A, working power of 18kW, and can connect to a maximum of 3 inverters, and 6 batteries.</li> <li>• BCB-22-WW-0: <ul style="list-style-type: none"> <li>◦ Used with LX A5.0-10, the battery system supports a maximum working current of 720A, working power of 36kW, and can connect to a maximum of 6 inverters, and 12 batteries..</li> <li>◦ Used with LX A5.0-30, the battery system supports a maximum working current of 720A, working power of 36kW, and can connect to a maximum of 6 inverters, and 6 batteries.</li> <li>◦ Used with LX U5.0-30, the battery system supports a maximum working current of 720A, working power of 36kW, and can connect to a maximum of 6 inverters, and 6 batteries.</li> </ul> </li> <li>• BCB-32-WW-0: <ul style="list-style-type: none"> <li>◦ Used with LX A5.0-10, the battery system supports a maximum working current of 720A, working power of 36kW, and can connect to a maximum of 6 inverters, and 15 batteries..</li> <li>◦ Used with LX A5.0-30, the battery system supports a maximum working current of 720A, working power of 36kW, and can connect to a maximum of 6 inverters, and 15 batteries..</li> <li>◦ Used with LX U5.0-30, the battery system supports a maximum working current of 720A, working power of 36kW, and can connect to a maximum of 6 inverters, and 6 batteries.</li> <li>◦ Used with GW14.3- BAT-LV-G10, the battery system supports a maximum working current of 720A, working power of 36kW, and can connect to a maximum of 6 inverters, and 15 batteries.</li> </ul> </li> <li>• BCB-33-WW-0: <ul style="list-style-type: none"> <li>◦ Used with LX U5.0-30, the battery system</li> </ul> </li> </ul>

Product Type	Model	Description
		<p>supports a maximum working current of 720A, working power of 36kW, and can connect to a maximum of 6 inverters, and 15 batteries.. When the number of batteries exceeds 8, two 600A fuses need to be connected in parallel..</p> <ul style="list-style-type: none"> <li>Others: Please prepare busbar based on actual system power and current.</li> </ul>
Smart Meter	<ul style="list-style-type: none"> <li>Built-in Smart Meter (Standard)</li> <li>GMK110 (purchase from GoodWe)</li> <li>GM330 (purchase from GoodWe)</li> </ul>	<ul style="list-style-type: none"> <li>Built-in smart meter: When the number of parallel inverters <math>\leq 2</math> and the CT cable length <math>\leq 10</math> meters, the built-in smart meter can be used. Built-in smart meter: 10-meter wire CT, default CT ratio: 120A/40mA.</li> <li>GMK110: When the length of the inverter's built-in CT cable is insufficient to reach the distribution panel, an external GMK110 electricity meter can be used for extension. It is not supported to change the CT to other type, CT ratio: 120A/40mA.</li> <li>GM330: Supports purchasing from GOODWE or third-party, CT ratio requirement: nA/5A</li> <li>nA: CT Primary side input current, the range of n is 200-5000</li> <li>5A: CT Secondary side output voltage.)</li> </ul>
Communication Module	<ul style="list-style-type: none"> <li>WiFi/LAN Kit-20 (Standard)</li> <li>4G Kit- CN-G20 (Only for China)</li> <li>4G Kit- CN-G21 (Only for China)</li> </ul>	<p>For a single inverter unit, use the WiFi/LAN Kit-20, 4G Kit-CN-G20, or 4G Kit-CN-G21 module.</p>

Product Type	Model	Description
On-Grid Inverter	-	<ul style="list-style-type: none"> <li>• It's recommended to use on-grid inverter sold in GOODWE, and is supported to use the third-party on-grid inverter.</li> <li>• In microgrid systems, make sure that the rated output power of the on-grid inverter <math>\leq</math> the rated output power of the hybrid inverter.</li> <li>• When the coupled system is in parallel, if power limitation is required, make sure: <ul style="list-style-type: none"> <li>◦ the hybrid inverter should be set in the on-grid power limit interface of the SolarGo APP, and the on-grid inverter should be set according to the actual instruments used.</li> <li>◦ In order to ensure that the on-grid inverters can continue to generate power, the output power of the hybrid inverters must be adjusted in <b>the microgrid mode</b> interface of the SolarGo APP.</li> </ul> </li> </ul> <p>Note: The output power control precision of different on-grid inverters varies. Please set the on-grid power limit control parameter value according to the actual situation.</p>

## 3.2 Product Overview

### 3.2.1 Inverter

Inverter controls and optimizes power through an integrated energy management system in the photovoltaic system. The electricity generated by the photovoltaic system can be supplied to the load, stored in Battery, or exported to Utility grid, among other functions.

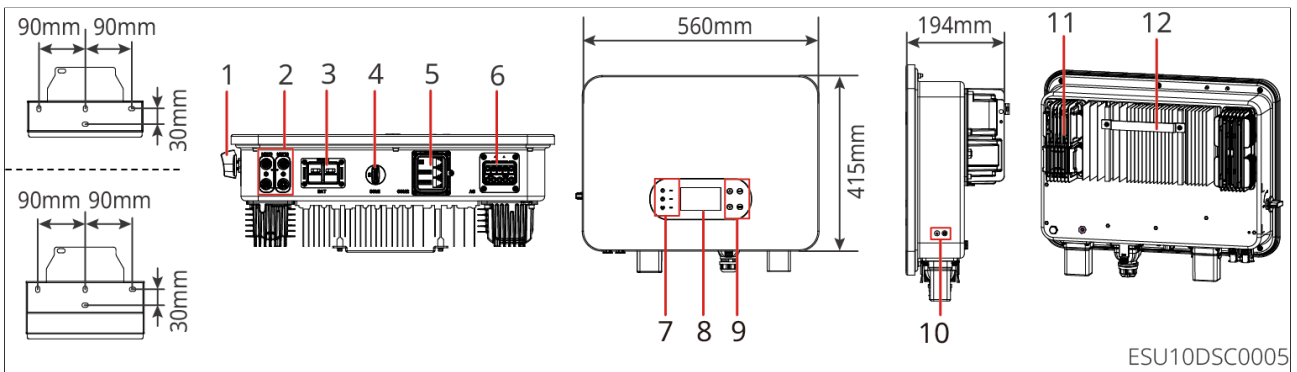

No.	Model	Nominal Output Power	Nominal Output Voltage
1	GW3000-ES-C10	3000W	220/230/240
2	GW3000-ES-C11	3000W	220/230/240
3	GW3600-ES-C10	3600W	220/230/240
4	GW5000-ES-C10	5000W	220/230/240
5	GW6000-ES-C10	6000W	220/230/240

### 3.2.2 Battery

The battery system stores and releases electricity based on the requirements of a PV energy storage system. The input and output ports of the energy storage system are both high-voltage direct current. The ES Uniq inverter supports connecting lead-acid batteries, and the product material of the battery can be obtained from the battery manufacturer.

#### 3.2.2.1 LX A5.0-10

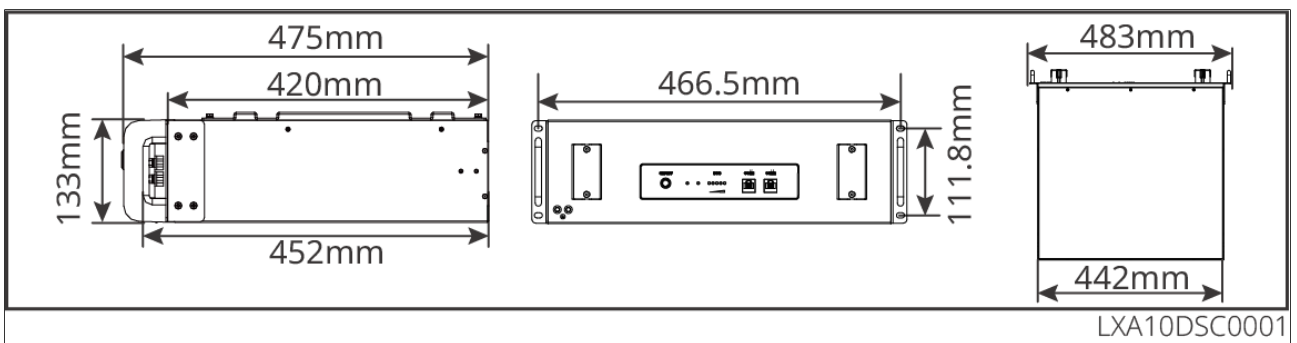

#### 3.2.2.2 LX A5.0-30

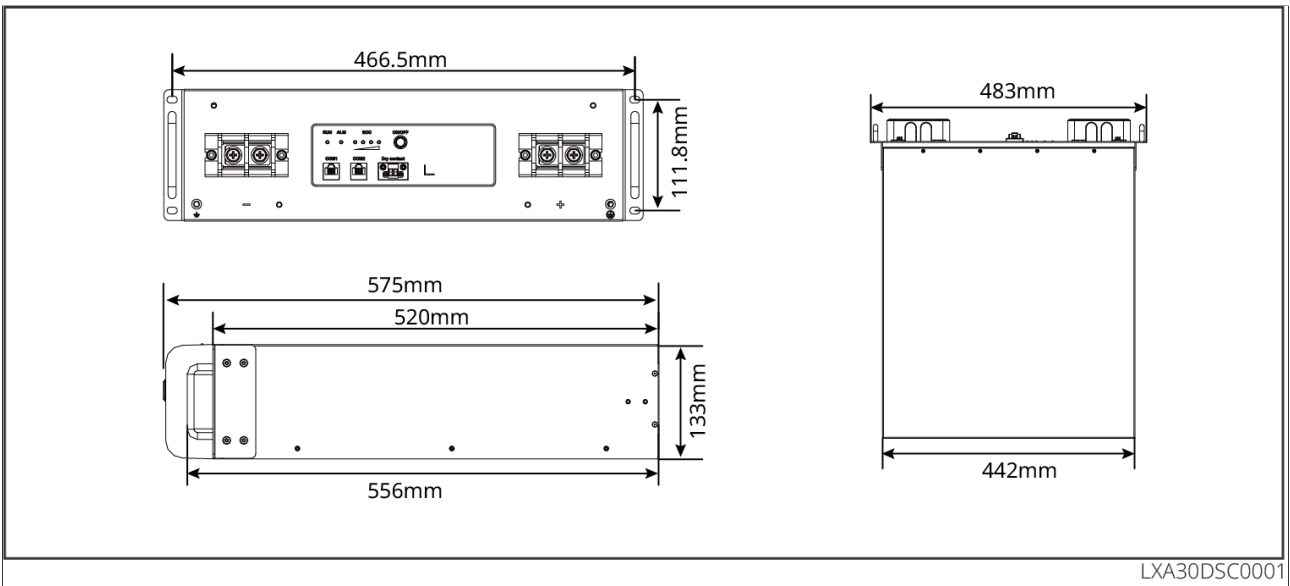

### 3.2.2.3 LX U5.0-30

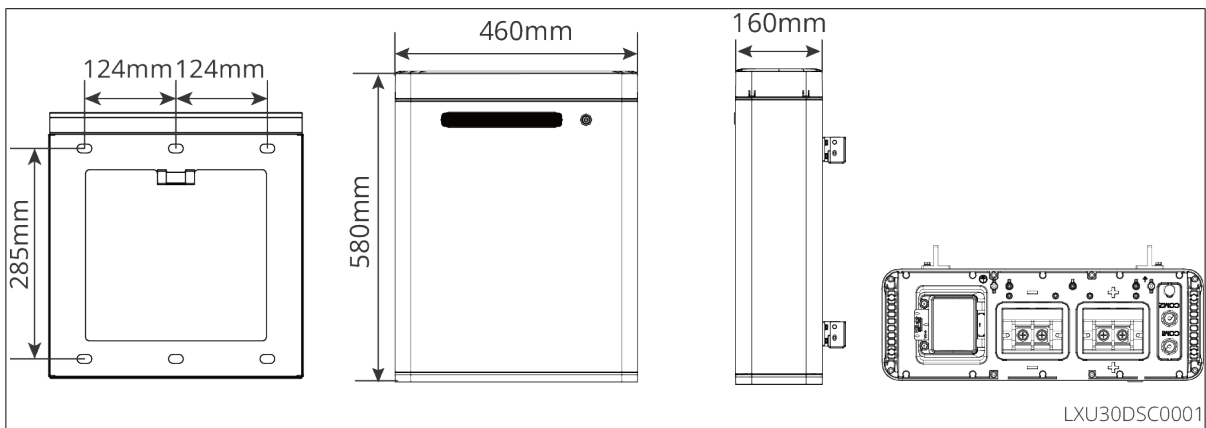

### 3.2.2.4 GW14.3-BAT-LV-G10



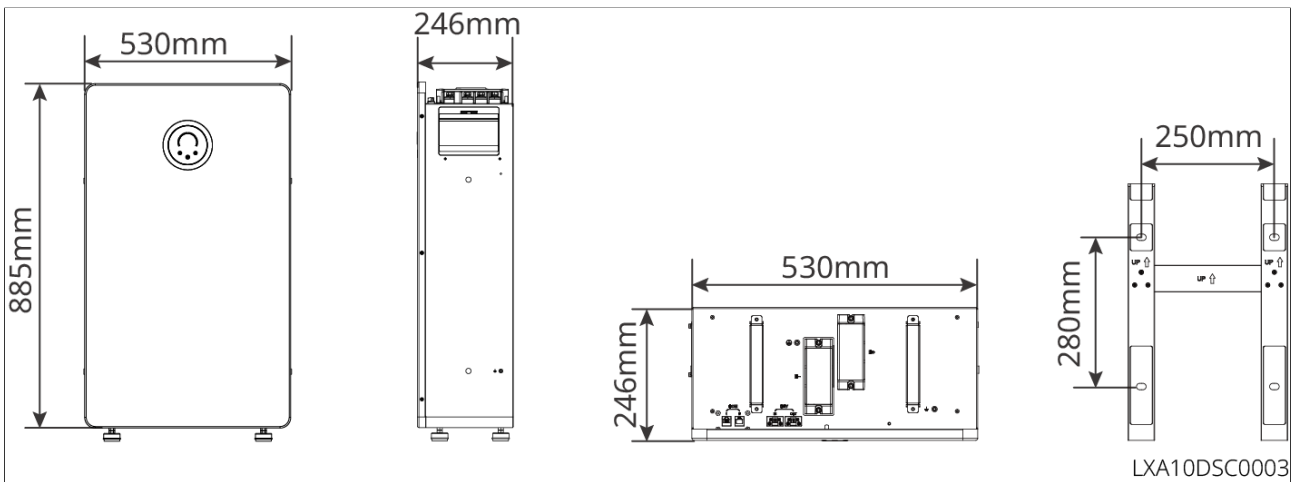

### 3.2.3 Smart Meter

The smart meter can measure and monitor the data in the photovoltaic energy storage system, such as voltage, current, frequency, power factor, and power, etc..

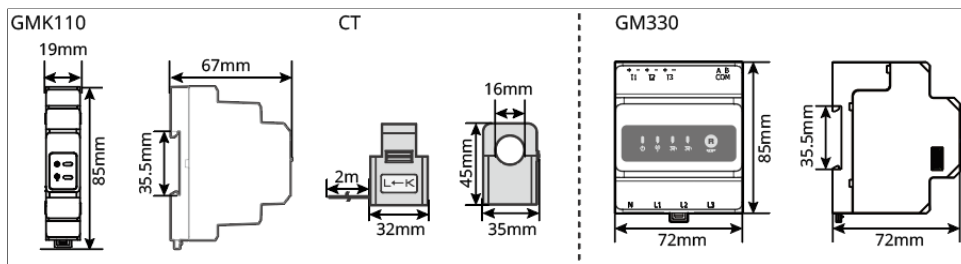

No.	Model	Applicable scenarios
1	GMK110	CT is not supported for changing to other type, CT ratio: 120A: 40mA
2	GM330	Order the CT for GM330 from GoodWe or other suppliers. CT ratio: nA: 5A <ul style="list-style-type: none"> <li>nA: For the primary input current of CT, n ranges from 200 to 5000.</li> <li>5A: CT secondary output current.</li> </ul>

### 3.2.4 Smart Dongle

The smart dongle can transmit various power generation data to SEMS Portal, the remote monitoring platform, in real time, and can communicate with the SolarGo App to complete the near-end equipment commissioning.

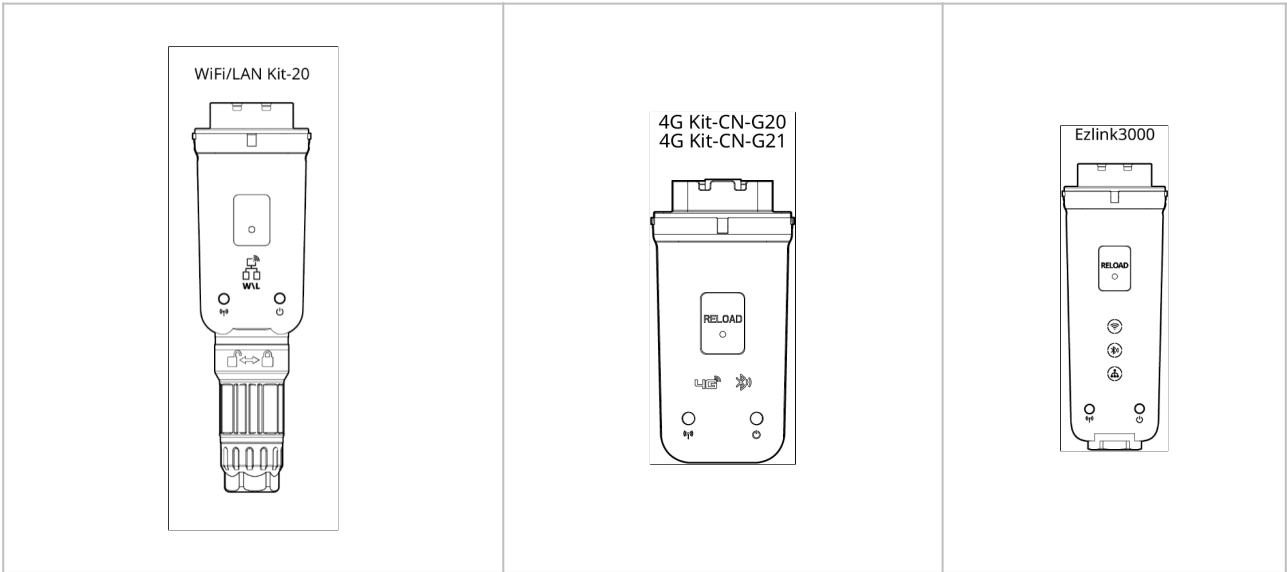

No.	Model	Signal	Applicable scenarios
1	WiFi/LAN Kit-20	Bluetooth, WiFi, LAN	Single inverter scenario
2	4G Kit-CN-G20	Bluetooth, 4G	
3	4G Kit-CN-G21	4G, bluetooth, GNSS	
4	Ezlink3000	Bluetooth, WiFi, LAN	Master inverter of a parallel system

### 3.3 Supported Grid Types

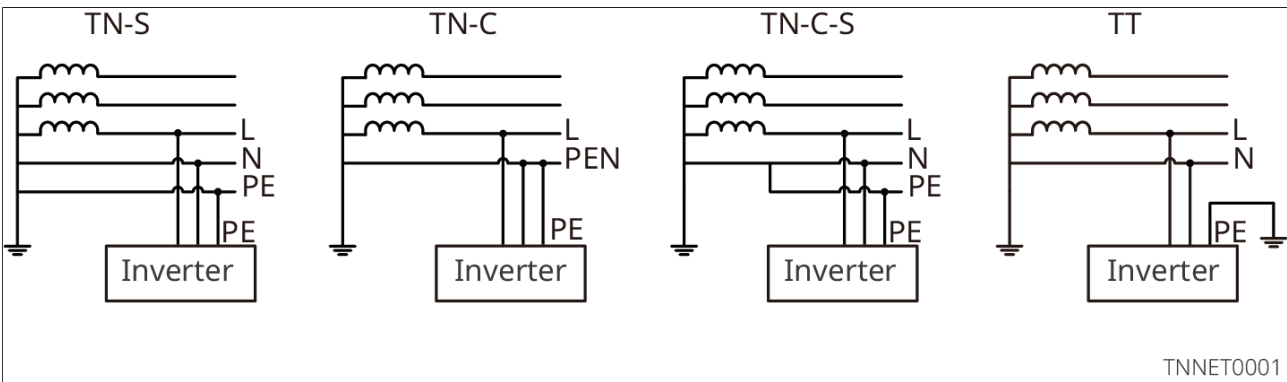

### 3.4 System Working Mode

## NOTICE

After the GW14.3-BAT-LV-G10 battery system is installed for the first time, it will automatically perform a full charge of the battery. Once completed, it will switch to the set operating mode.

## Self-use Mode

- Self-use mode is the basic working mode of the system.
- The power generated by the PV system supply the loads in priority; the excess power will charge the batteries, and then the remaining power will be sold to the utility grid. When the power generated in the PV system is insufficient, the battery will supply the loads in priority. If the battery power is insufficient, the load will be powered by the utility grid.

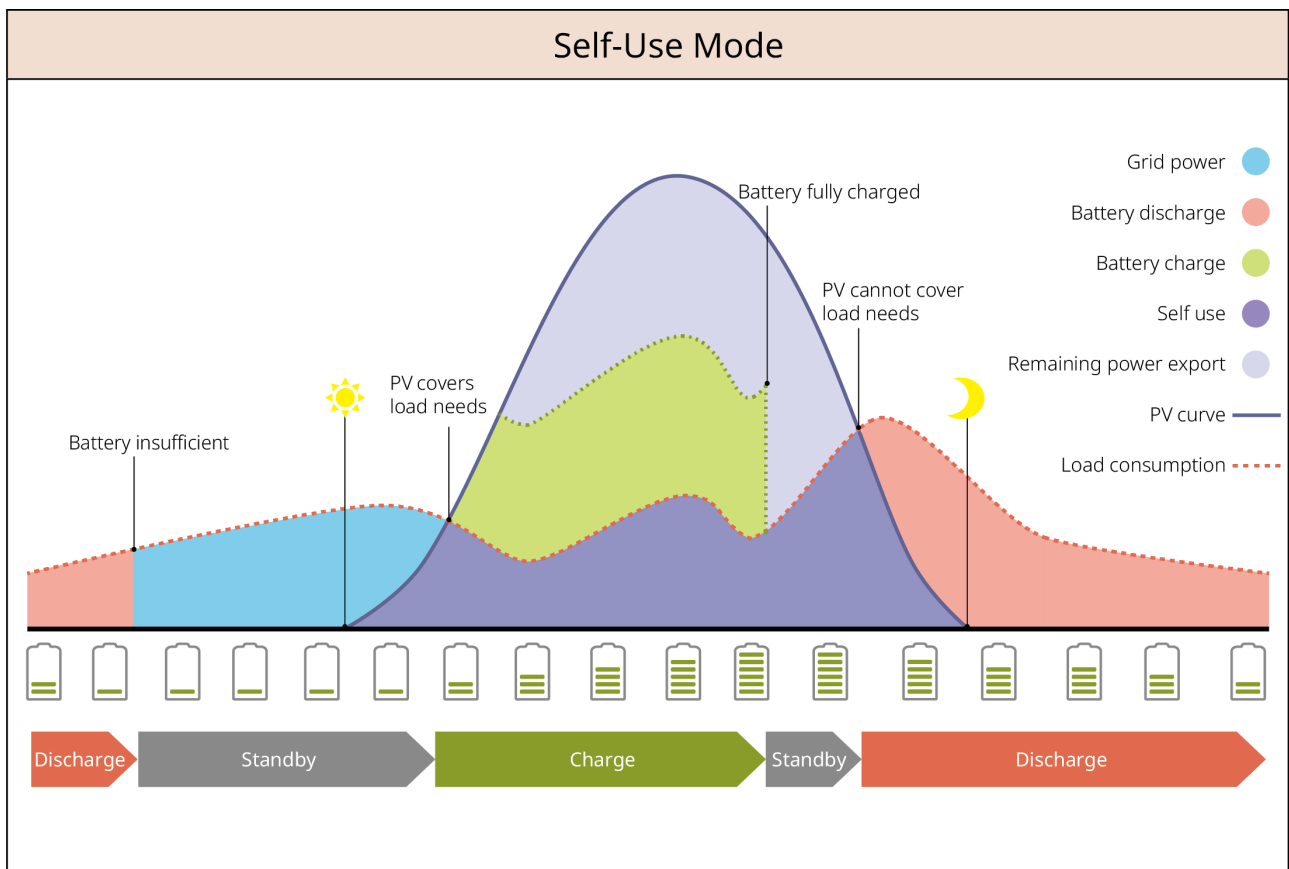

SLG00NET0009

## BACK-UP Mode

- The BACK-UP mode is mainly applied to the scenario where the grid is unstable.
- When the grid is disconnected, the inverter turns to off-grid mode and the battery

will supply power to the BACK-UP loads; when the grid is restored, the inverter switches to on-grid mode.

- To ensure that the battery SOC is sufficient to maintain normal operation of the system when it is off grid, the battery will be charged to the backup power SOC using PV or grid power during on-grid operation. If you need to purchase electricity from the power grid to charge the battery, please confirm compliance with local power grid laws and regulations.

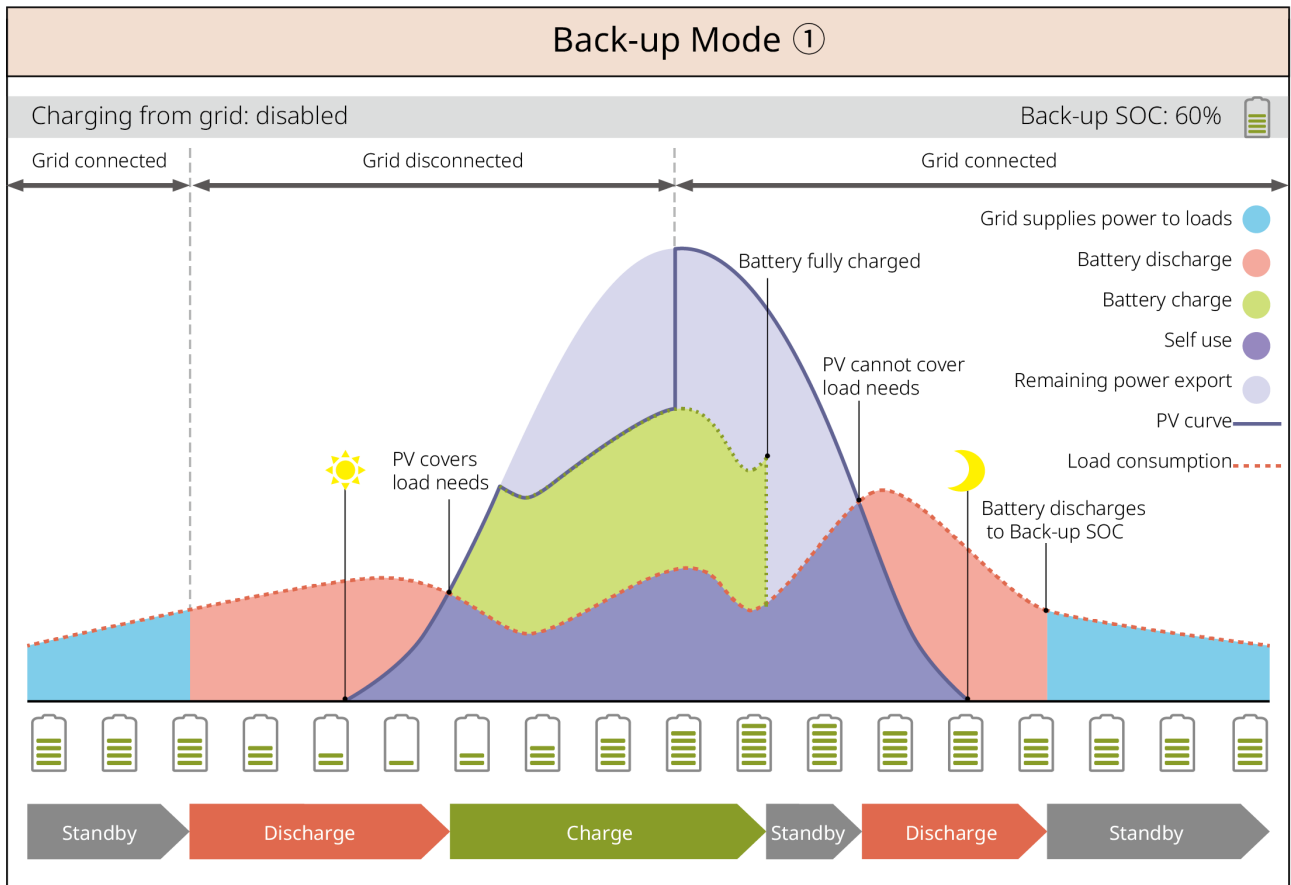

SLG00NET0002

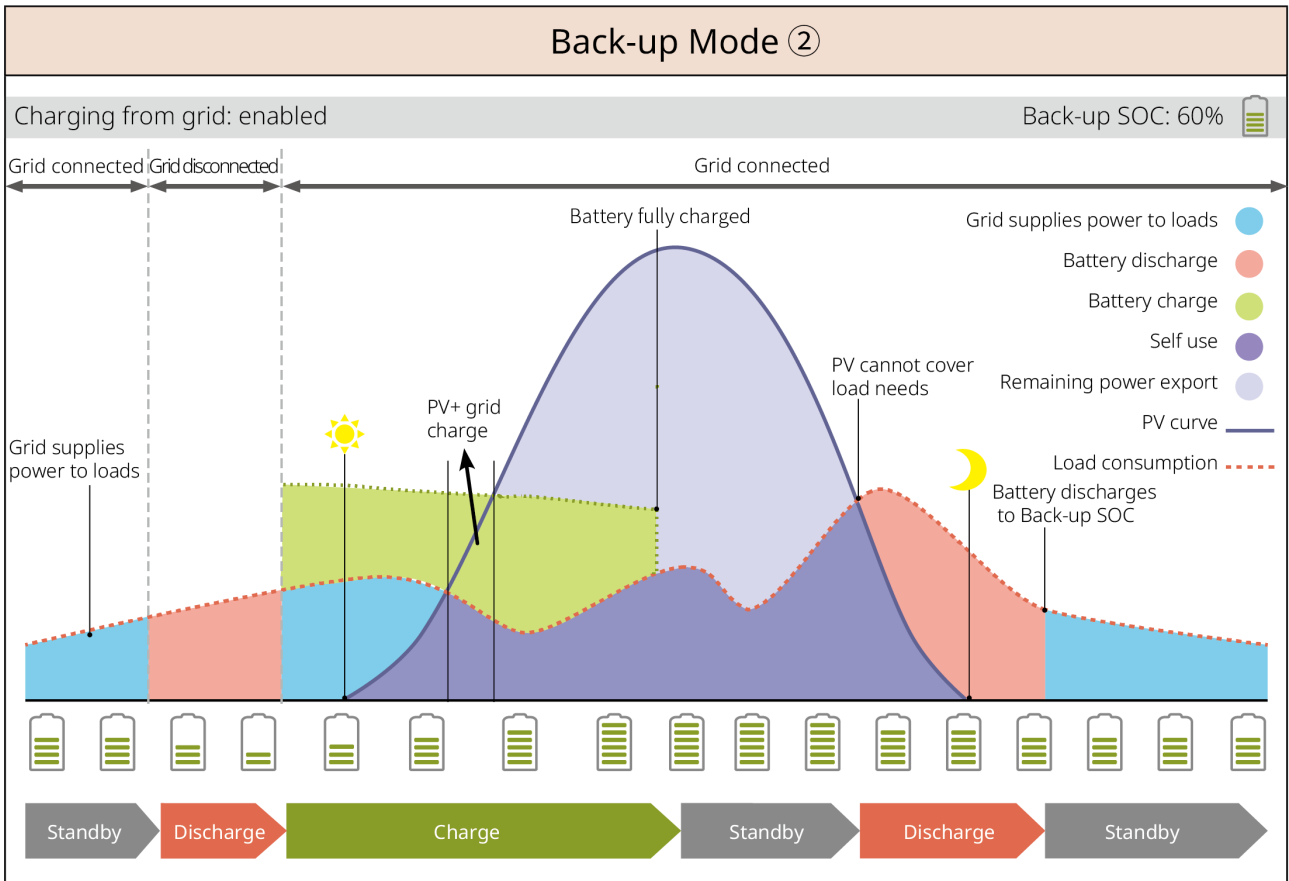

## TOU Mode

It is recommended to use TOU mode in scenarios when the peak-valley electricity price varies a lot. Select TOU mode only when it meets the local laws and regulations. For example, set the battery to charge mode during Valley period to charge battery with grid power. And set the battery to discharge mode during Peak period to power the load with the battery.

# TOU Mode ①

PV: Charge battery in priority

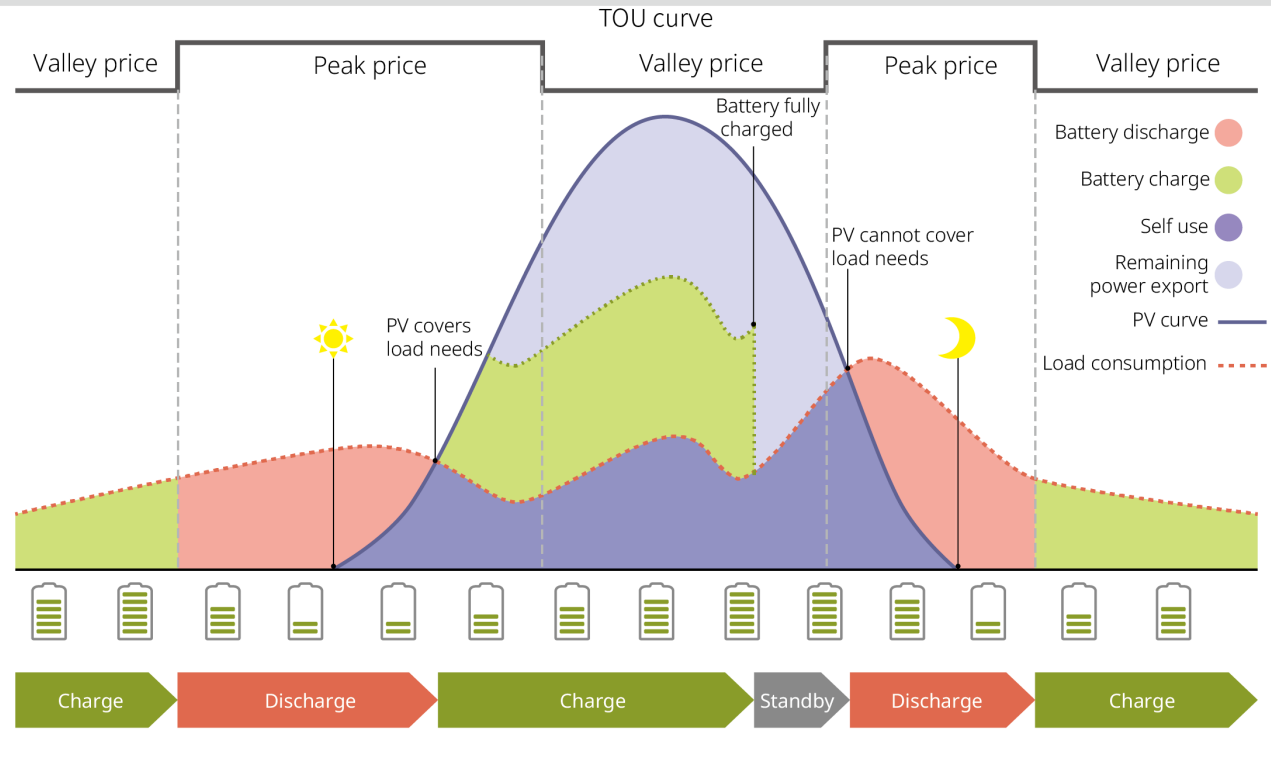

SLG00NET0004

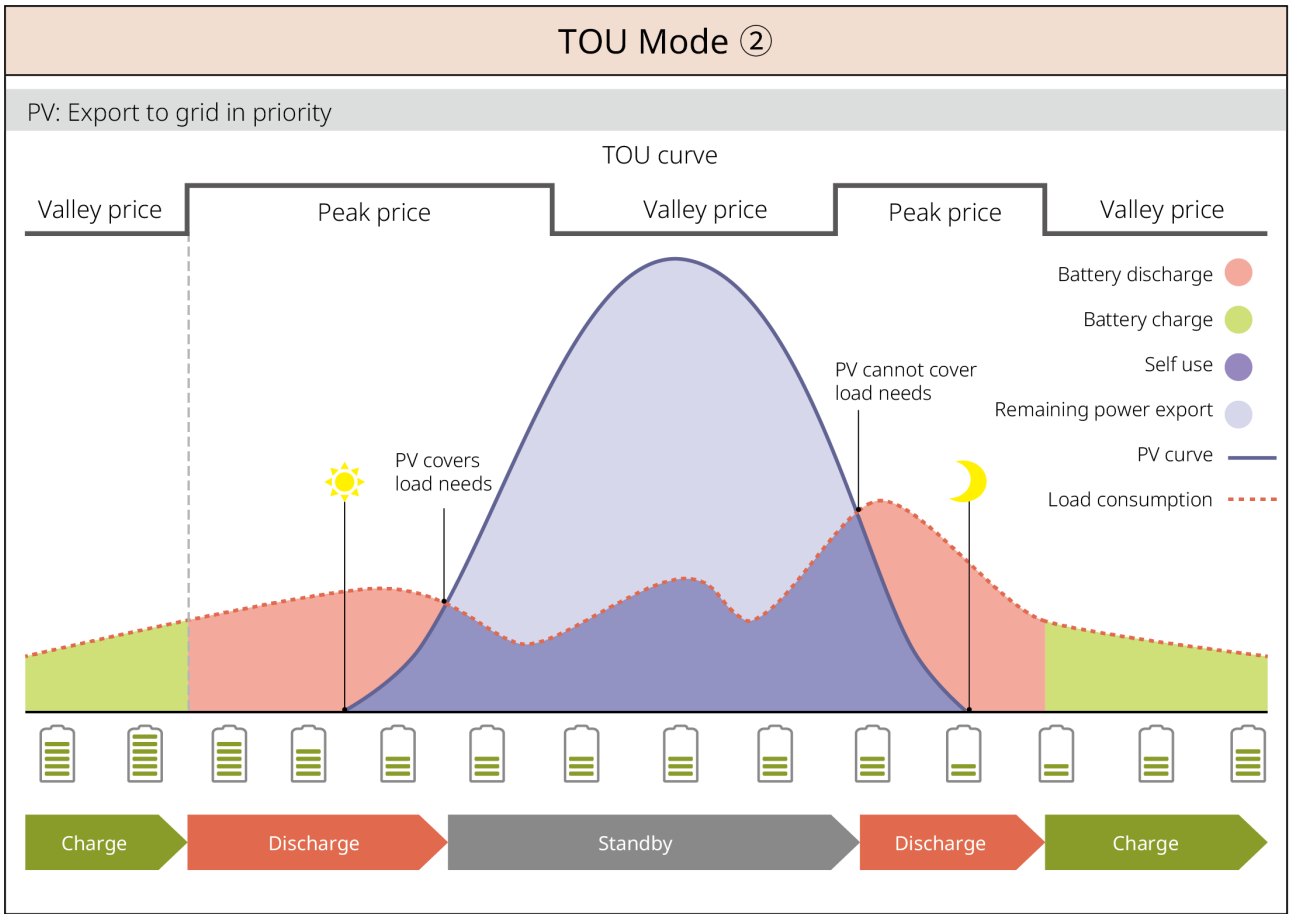

SLG00NET0005

### Delayed Charging Mode

- Suitable for areas with on-grid power output restrictions.
- Setting a peak power limit allows the PV power that exceeds the on-grid limit to be used to charge the battery; or setting a PV charging time period, during which the PV power is utilized to charge the battery.

# Smart Charging ①

PV > Peak Limit

Switch to Charge: enabled/disabled

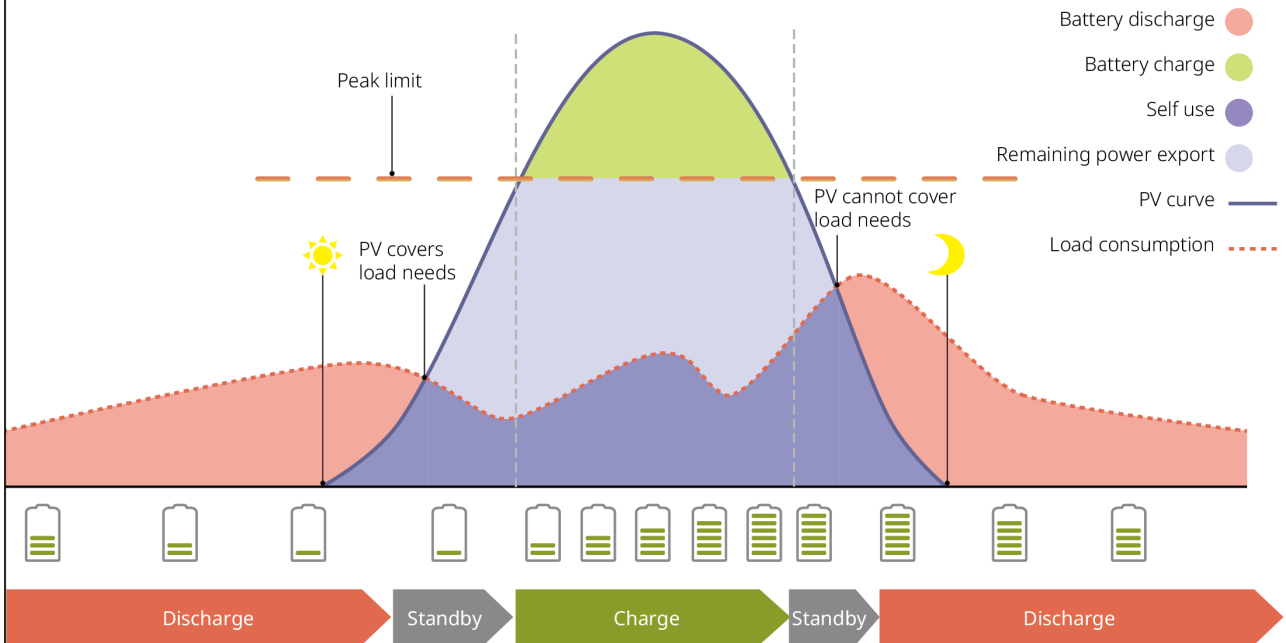

SLG00NET0006



## Smart Charging ②

PV < Peak Limit

Switch to Charge: enabled

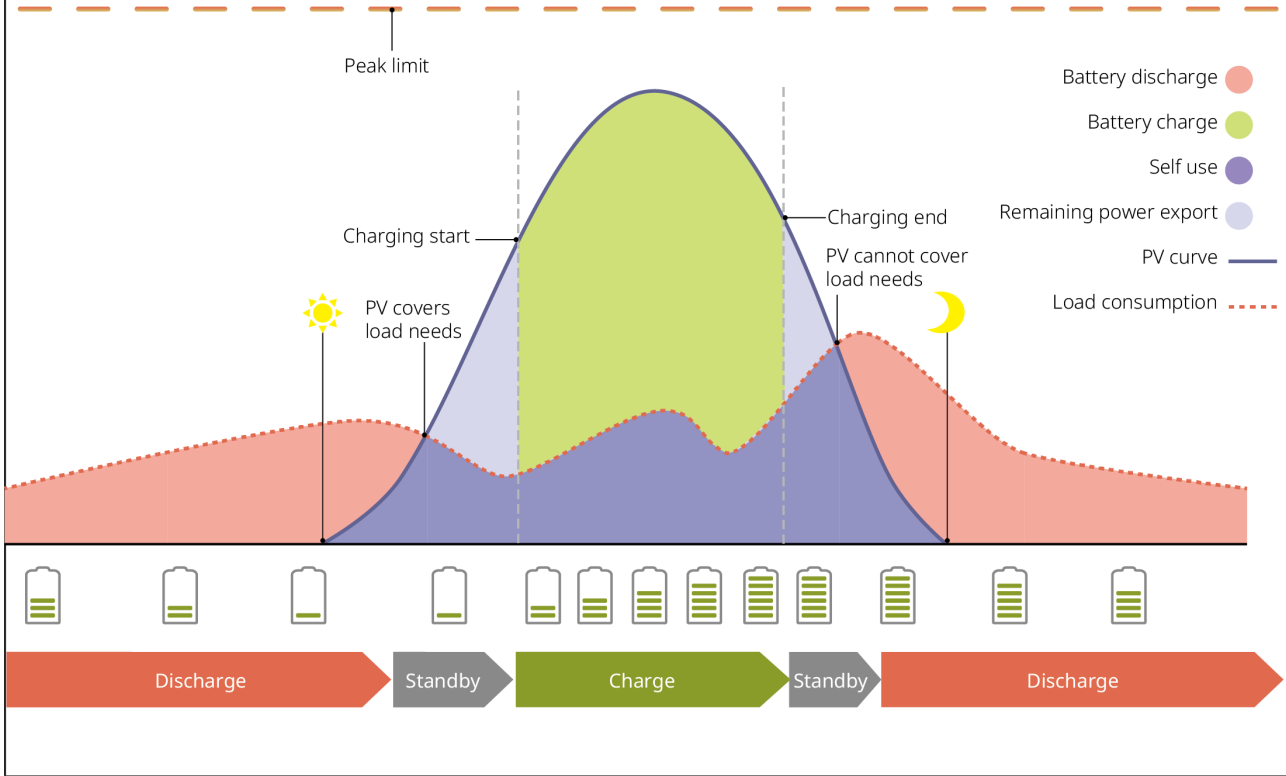

SLG00NET0007

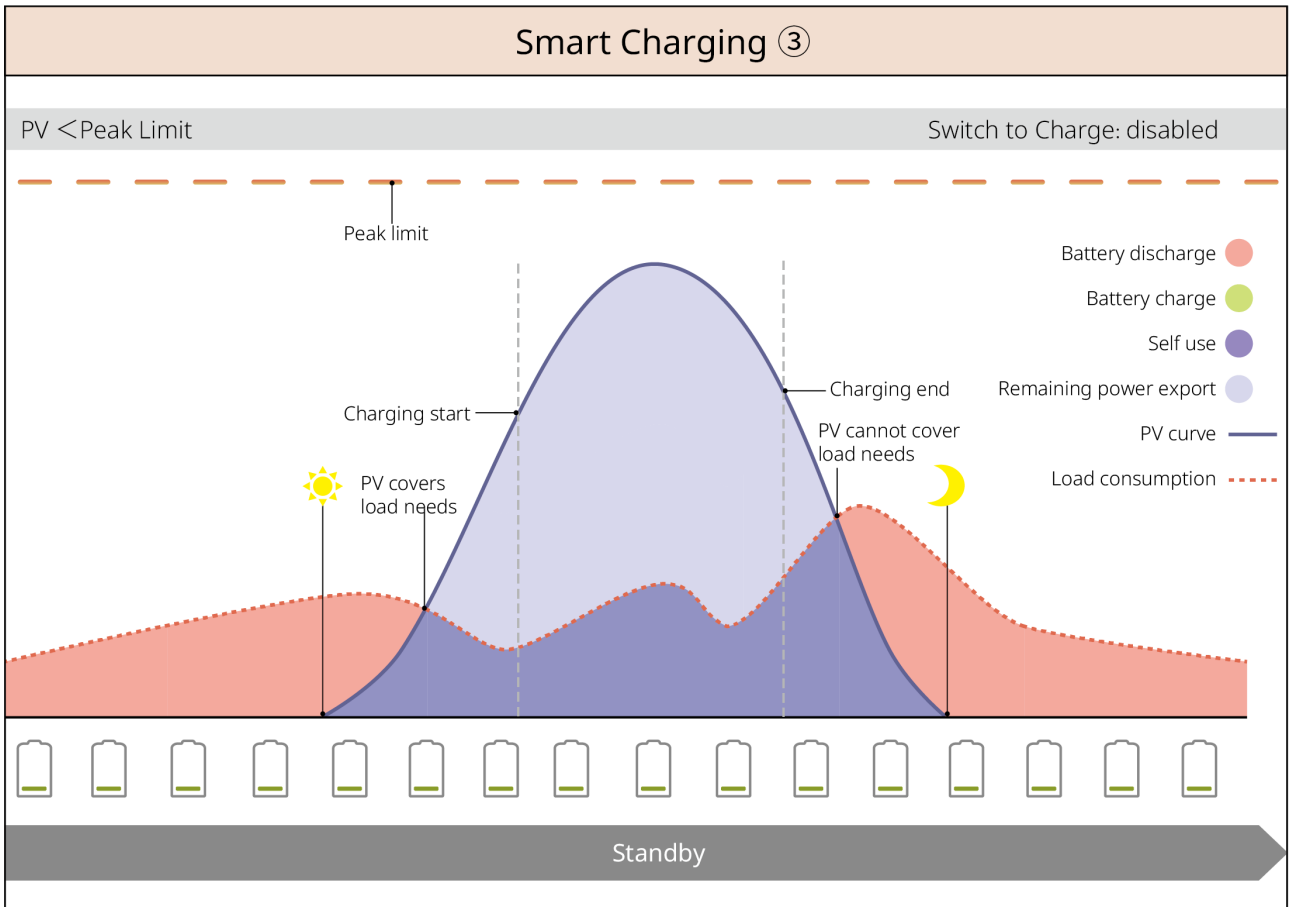

### Demand Management Model

- It is mainly applicable to industrial and commercial scenarios.
- When the total power consumption of the load exceeds the power quota within a short period of time, battery discharge can be used to reduce the amount of power consumption exceeding the quota.
- When the SOC of both battery strings in the inverter falls below the reserved SOC for demand management, the system purchases electricity from the grid based on the time period, load electricity consumption, and peak purchase limit. When the SOC of only one battery string in the inverter falls below the reserved SOC for demand management, the system purchases electricity from the grid based on load electricity consumption and the peak purchase limit.

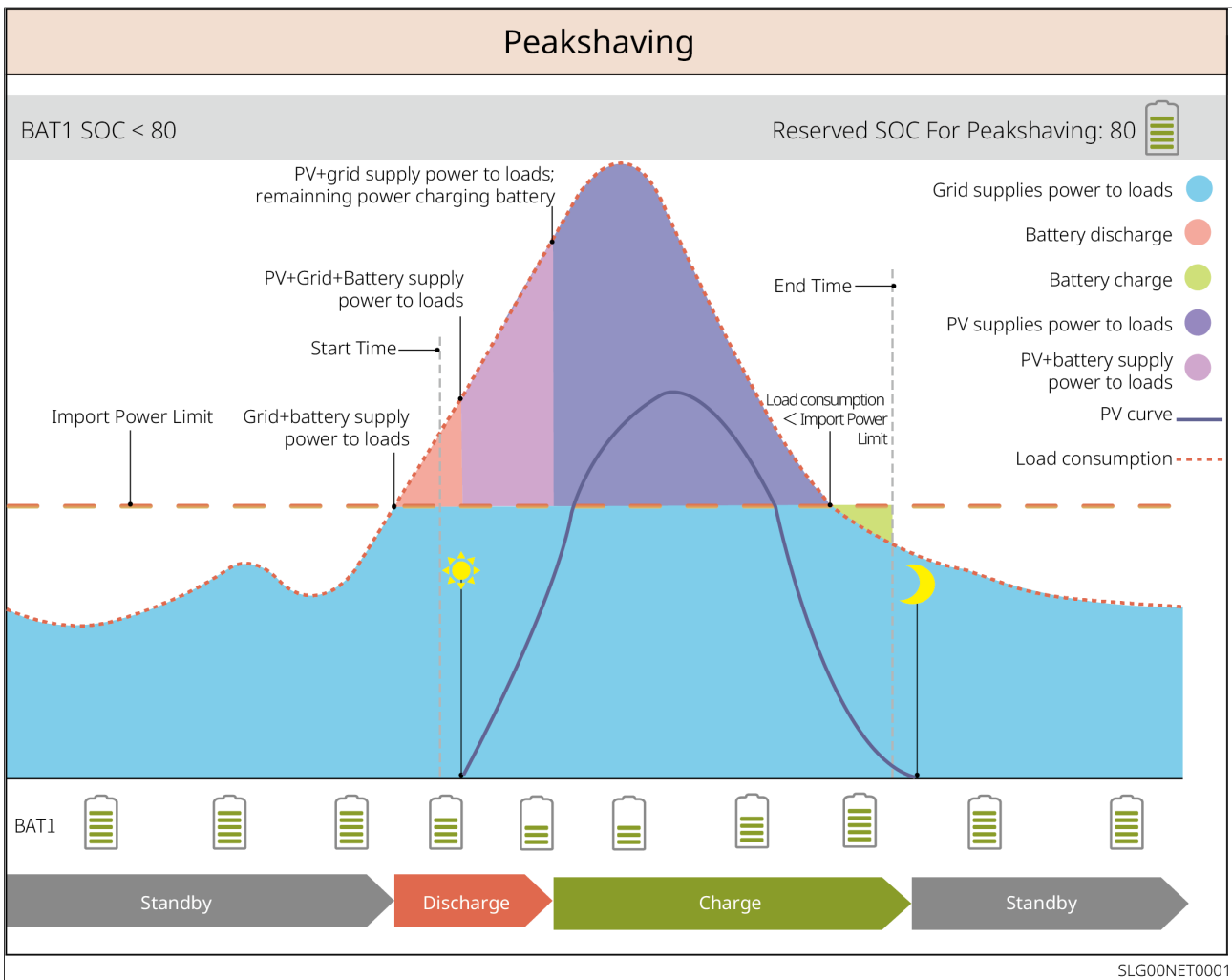

## Off-grid Mode

### NOTICE

Please do not operate the energy storage system in pure off-grid mode for long periods of time, otherwise there is a risk of over-discharge when the battery cannot be charged in low temperature or low light conditions.

When the power grid fails, the inverter switches to off-grid mode.

- During the day, PV power generation is prioritized for supplying power to loads, and excess power is used to charge batteries.
- Nighttime battery discharge powers the load to ensure uninterrupted power supply to the backup load.
- Off-grid SOC recovery: After the system goes offline, the battery gradually recovers to the minimum SOC through photovoltaic power generation or other power

generation methods.

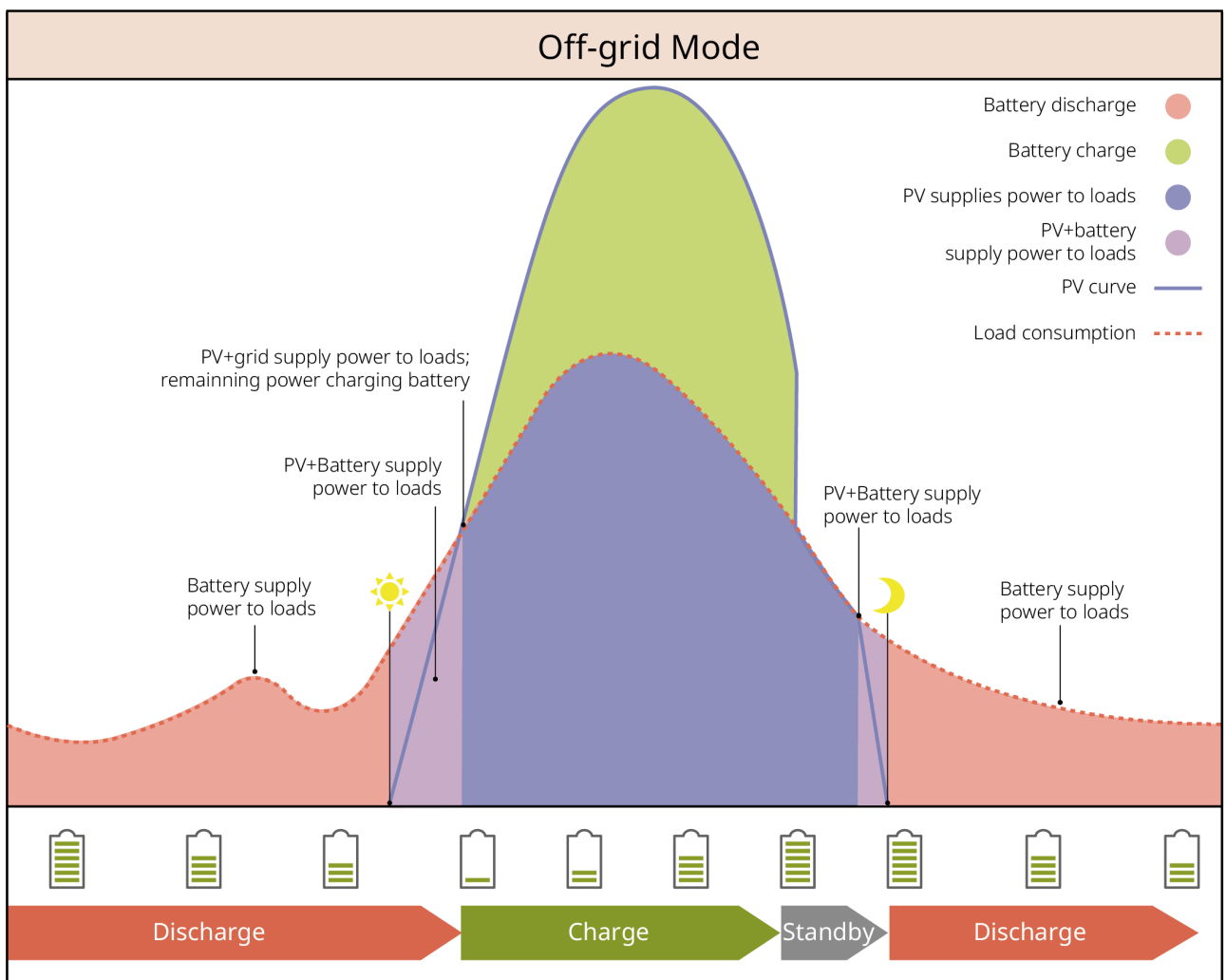

SLG00NET0012

### 3.5 Features

#### AFCI

The inverter is equipped with an integrated AFCI circuit protection device for detecting arc faults (arc fault) and quickly cutting off the circuit when detected, thus preventing electrical fires.

Reasons for the occurrence of electric arcs:

- Damaged connectors in the PV system.
- Wrong connected or broken cables.
- Aging connectors and cables.

## Troubleshooting:

1. When the inverter detects an arc, the type of barricade can be viewed through the inverter display or the App.
2. If the inverter triggers a fault less than 5 times in 24 hours, wait 5 minutes and the machine will automatically resume grid-tied machine protection. After the 5th electric arc fault, the inverter can operate normally after the fault is solved. For more details, refer to the SolarGo APP User Manual.

## Load control

Inverter dry contact control port to support connection of additional contactors for controlling loads on or off. Supports domestic loads, heat pumps, etc..

The load control methods are as follows:

- Time Control: Set the time to control the load to turn on or off, and the load will be automatically turned on or off in the set time period.
- Switch Control: When the control mode is selected as ON, the load will be turned on; when the control mode is set to OFF, the load will be turned off.
- BACK-UP LOAD CONTROL: The inverter has a built-in relay dry contact control port to control whether the load is turned off or not via a relay. In off-grid mode, the load connected to the relay port can be turned off if the overloaded battery SOC value at the BACK-UP end is detected to be lower than the battery off-grid protection setting.

## Rapid Shutdown (RSD)

In the rapid shutdown system, the transmitter is used in conjunction with a receiver to achieve the rapid shutdown of the system. The receiver maintains the component output by receiving signals from the transmitter. The transmitter can be external or built into the inverter. In the event of an emergency, the component can be shut down by enabling an external trigger to stop the transmitter.

- External Transmitter
  - Transmitter Model: GTP-F2L-20, GTP-F2M-20  
<https://www.goodwe.com/Ftp/Installation-instructions/RSD2.0-transmitter.pdf>
  - Receiver Model: GR-B1F-20, GR-B2F-20  
[https://en.goodwe.com/Ftp/EN/Downloads/User%20Manual/GW\\_RSD-20\\_Quick-Installation-Guide-POLY.pdf](https://en.goodwe.com/Ftp/EN/Downloads/User%20Manual/GW_RSD-20_Quick-Installation-Guide-POLY.pdf)
- Built-in Transmitter
  - External trigger device: AC side circuit breaker

- Receiver Model: GR-B1F-20, GR-B2F-20

[https://en.goodwe.com/Ftp/EN/Downloads/User%20Manual/GW\\_RSD-20\\_Quick-Installation-Guide-POLY.pdf](https://en.goodwe.com/Ftp/EN/Downloads/User%20Manual/GW_RSD-20_Quick-Installation-Guide-POLY.pdf)

## 4 Check and Storage

### 4.1 Check Before Receiving

Check the following items before accept.



1. Check the outer packing box for damage, such as holes, cracks, deformation, and other signs of equipment damage. Do not unpack the package and contact the supplier as soon as possible if any damage is found.
2. When removing the GW14.3-BAT-LV-G10 battery, make sure that the packaging carton is intact. If the packaging is damaged and you need to return or exchange the product due to quality issues, please contact GoodWe after-sales service or your dealer to obtain a special packaging box.
3. Check the product model. If the product model is not what you requested, do not unpack the product and contact the supplier.







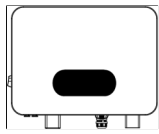
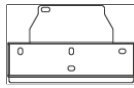
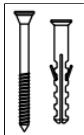

### 4.2 Deliverables

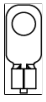
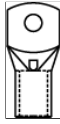
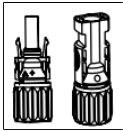
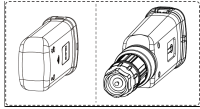

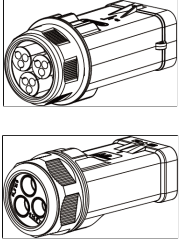
Check the deliverables for correct model, complete contents, and intact appearance. Contact the supplier as soon as possible if any damage is found.

#### 4.2.1 Inverter Deliverables

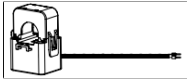
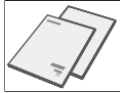
Component	Description	Component	Description
	Inverter x 1		Mounting plate x 1
	Expansion screws x 4		Grounding screw x 1



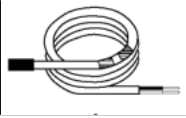
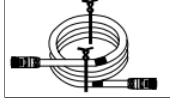
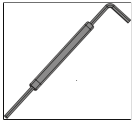

Component	Description	Component	Description
	Protective grounding terminal x 1		Battery power connection terminal x 2
	PV DC terminal <ul style="list-style-type: none"> <li>• GW3000-ES-C10、GW3000-ES-C11 x 1</li> <li>• Others x 2</li> </ul>		Smart dongle x 1
	2PIN terminal x1		6PIN terminal x 2
	AC terminal x 1 Provided on an actual basis.		Battery Connector x 1
	PIN communication terminal x 20		AC PIN terminal x 10
	CT x 1		Documents x 1
	Lead-acid battery temperature sensor cable fixing sticker x 2		One-piece screwdriver x 1





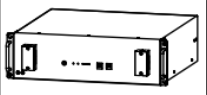
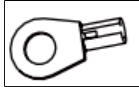

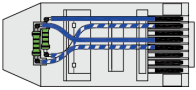
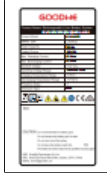
Component	Description	Component	Description
	Lead-acid battery temperature sensor cable x 1		BMS communication cable x 1
	AC unlocking tool x1		

## 4.2.2 Batteries Deliverables

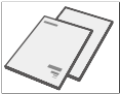
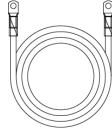
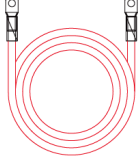
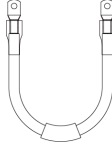
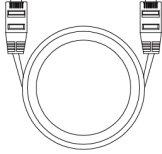
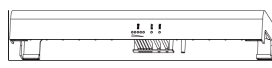

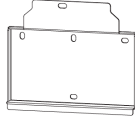

### 4.2.2.1 LX A5.0-10

Component	Description	Component	Description
	Battery module x1		(25--8) OT terminal x 4 (5.5--5) OT terminal x 2
	M5 grounding screw x 2		Warning label x 1
	Terminal resistor x 1		Electrical Label x 1
	M4*8 screw x 8 (optional) Provided when selecting bracket installation method.		Battery bracket x 2 (optional) Provided when selecting bracket installation method.



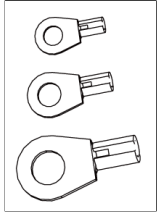
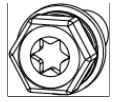
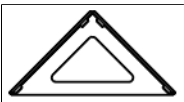
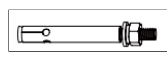
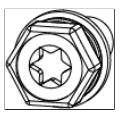
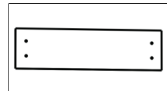

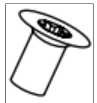
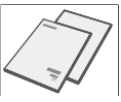
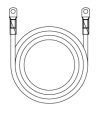
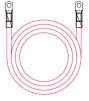
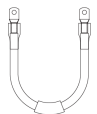

Component	Description	Component	Description
	Documents x 1		Negative power line (optional) x 1
	Positive power line (optional) x 1		Grounding cable (optional) x 1
	Communication cable (optional) x 1		Decorative cover (optional) x 1
	Mounting plate bracket expansion screws (optional) x 4		Mounting plate (optional) x 1
	Bracket (optional) x 1		Bracket screws (optional) x 4

#### 4.2.2.2 LX A5.0-30

Component	Description	Component	Description
	Battery module x1		Terminal resistor x 1 When connecting to a third-party busbar, this terminal resistor needs to be installed.

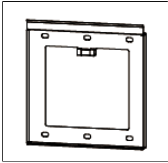

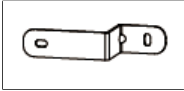
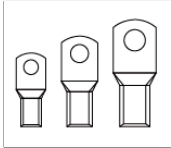

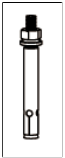
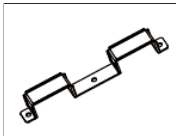



Component	Description	Component	Description
	<ul style="list-style-type: none"> <li>• M5 OT terminal x 2: Recommended for 10mm<sup>2</sup> cable</li> <li>• M8 OT terminal x 4: Recommended for 50mm<sup>2</sup> cable</li> <li>• M10 OT terminal x 2: Recommended for 70mm<sup>2</sup> cable</li> </ul>		M5*12 grounding screw x 2
	Bracket x 2 For wall-mounted installation		M6* 70 Expansion bolts x 4 For wall-mounted installation
	M5*12 grounding screw x 2 For wall-mounted installation		Line drawing template x 1 For wall-mounted installation
	Battery bracket x 2 (optional) For floor-mounted installation		M4*8 screw x 8 For floor-mounted installation
	Documents x 1		Negative power line (optional) x 1
	Positive power line (optional) x 1		Grounding cable (optional) x 1
	Communication cable (optional) x 1		Decorative cover (optional) x 1

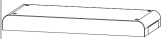

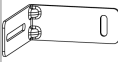
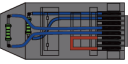

#### 4.2.2.3 LX U5.0-30

Component	Description	Component	Description
	Battery module x1		Cover x 1
	Mounting plate x 1		Expansion bolt x 2
	Locking bracket x 2		<ul style="list-style-type: none"> <li>• 35-8 OT terminal x 4: Recommended for connecting 25mm<sup>2</sup> or 35mm<sup>2</sup> cables</li> <li>• 50-8 OT terminal x 4: Recommended for 50mm<sup>2</sup> cable</li> <li>• 70-10 OT terminal x 2: Recommended for 70mm<sup>2</sup> cable</li> </ul>
	14--5 Grounding terminal x 2		M5 Screw x 7
	M10 Expansion bolt x 6		Cable harness fixing plate x 1

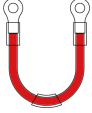

Component	Description	Component	Description
	Power connector protect cover x 2		Documents x 1
	Terminal resistor x 1	-	-

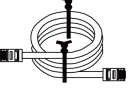
#### 4.2.2.4 Battery Deliverables (GW14.3- BAT-LV-G10)

Component	Description	Component	Description
	Battery x 1		Wire cover x 1
	Inverter handle x 1 (Shipped with the package after October 2025)		Expansion bolt x 2
	M5*16 internal cross external hexagon screw x 7		Wall locking anti-tip bracket x 2
	Terminal resistor x 1		Grounding OT terminal x 1 (Shipped with the package starting from October 2025)
	DC OT connector x 6 (Shipped with the package starting from October 2025)		Grounding cable (optional) x 1 (Shipped with the package after October 2025)

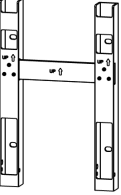
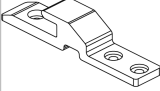
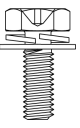

	Positive power cable (optional) x 1 (Shipped with the package after October 2025)		Negative power cable (optional) x 1 (Shipped with the package after October 2025)
	Communication cable x 1		Documents x 1

### Optional

Component	Description	Component	Description
	Wall mounting rack x 1		Hooks (optional) x 4
	M5*16 internal cross external hexagon (optional) x 12		M10 Expansion bolt x 4

## 4.2.3 Busbar Deliverables

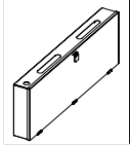

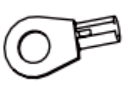
### 4.2.3.1 BCB-11-WW-0 (Optional)

Component	Description	Component	Description
	360A Manifold box x 1		M6 Expansion bolts x 4
	(25--8) OT terminal x 18 (70--10) OT terminal x 2	-	-

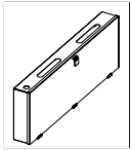
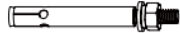
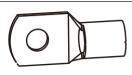
#### 4.2.3.2 BCB-22-WW-0

Component	Description	Component	Description
	360A Manifold box x 1		M6 Expansion bolts x 4
	(25--8) OT terminal x 36 (70--10) OT terminal x 6	-	-

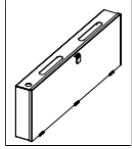

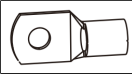

#### 4.2.3.3 BCB-32-WW-0, BCB-33-WW-0 (Optional)

Component	Description	Component	Description
	360A Manifold box x 1		M6 Expansion bolt x 4
	(50--8) OT terminal x 30 (70--10) OT terminal x 6	-	-

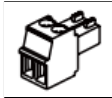



### 4.2.4 Smart Meter Deliverables

#### 4.2.4.1 GMK110

Component	Description	Component	Description
	Smart Meter and CT x 1		RS485 communication terminals x 1

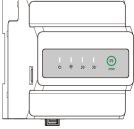

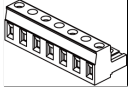
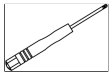
Component	Description	Component	Description
	Voltage input side terminal x 1		PIN terminal x 4
	Screw driver x 1		Documents x 1

#### 4.2.4.2 GM330

Component	Description	Component	Description
	Smart Meter x1		2 PIN terminal x1
	PIN terminal x 6		7 PIN terminal x1
	Screw driver x 1		Documents x 1



#### 4.2.5 Smart dongle

##### 4.2.5.1 WiFi/LAN Kit-20



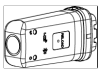

Component	Description	Component	Description
	Smart dongle x 1		Documents x 1

##### 4.2.5.2 4G Kit-CN-G20, 4G Kit-CN-G21

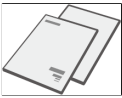

Component	Description	Component	Description
	Smart dongle x 1		Documents x 1

#### 4.2.5.3 Ezlink3000

Component	Description	Component	Description
	Smart dongle x 1		LAN cable connector x 1
	Documents x1		Unlock tool x1 Some modules need to be removed with the tool. If the tool is not provided, remove the module by pressing the unlock button on the module

### 4.3 Storage

If the equipment is not to be installed or used immediately, please ensure that the storage environment meets the following requirements: After the equipment is stored for a long period of time, it is required to be checked and confirmed by a professional before it can be used further.

1. If the inverter has been stored for more than two years or has not been in operation for more than six months after installation, it is recommended to be inspected and tested by professionals before being put into use.
2. To ensure good electrical performance of the internal electronic components of the inverter, it is recommended to power it on every 6 months during storage. If it has not been powered on for more than 6 months, it is recommended to be inspected and tested by professionals before being put into use.
3. In order to protect the performance and service life of the battery, it is

recommended to avoid unused storage for a long period of time. Prolonged storage may cause deep discharging of the battery, resulting in irreversible chemical loss, leading to capacity degradation or even complete failure, timely use is recommended. If the battery needs to be stored for a long period of time, please maintain it according to the following requirements:

Battery Model	Initial SOC Range for Battery Storage	Recommended Storage Temperature	Charge and Discharge Maintaining Period <sup>[1]</sup>	Battery Maintenance Method <sup>[2]</sup>
LX A5.0-10	30%~ 40%	0~35°C	-20~0°C, ≤1 month	Contact the dealer or the after-sales service for maintenance method.
n*LX A5.0-10			0~35°C, ≤6 months	
LX A5.0-30	30%~ 40%	0~35°C	-20~45°C, ≤6 months	
LX U5.0-30	30%~40%	0~35°C	-20~0°C, ≤1 month 0~35°C, ≤6 months 35~40°C, ≤1 month	
GW14.3-BAT-LV-G10	30%~40%	0~35°C	-20~35°C, ≤12 months 35~45°C, ≤6 months	

#### NOTICE

[1] The storage time starts from the SN date on the outer packaging of the battery and requires charging and discharging maintenance after the storage cycle is exceeded. (Battery maintenance time = SN date + charge/discharge maintenance cycle). For SN date, refer to [SN Code Meaning](#).

[2] After passing the charging/discharging maintenance, if there is a Maintaining Label attached to the outer box, then please update the maintenance information on the Maintaining Label. if there is no Maintaining Label, please record the maintenance time and SOC of the batteries by yourself and keep the data to facilitate the keeping of maintenance records.

#### **Packing requirements:**

Do not unpack the outer package or throw the desiccant away.

#### **Installation environment requirements:**

1. Place the equipment in a cool place where is away from direct sunlight.
2. Store the equipment in a clean place. Make sure the temperature and humidity are appropriate and there is no condensation. Do not install the equipment if the ports or terminals are condensed.
3. Keep the equipment away from flammable, explosive, and corrosive matters.

**Stacking requirements:**

1. The height and direction of the stacking inverter should follow the instructions on the packing box.
2. The inverter must be stacked with caution to prevent them from falling.

# 5 Installation



Install and connect the equipment with the deliverables included in the package. Otherwise, the manufacturer shall not be liable for the damage.

## 5.1 System Installation and Commissioning Procedure

Steps	1 Installation	2 PE	3 PV	4 Battery	5 AC	6 COM	7 Communication module		
Inverter							4G Kit-CN-G20 4G Kit-CN-G21 WiFi/LAN Kit-20 Ezlink3000		
Tools	1 D: 80mm φ: 8mm	M5 1.5-2N·m	Recommend: A-2546B	1 M8 5N·m 2 52mm 6-7N·m	1 M5 1.5-2N·m 2 65mm 10N·m	1 M4 1.5N·m 2 40mm 5-6N·m			
Steps	1 Installation						2 PE	3 Battery	4 COM
Battery	LXAS.0-10 LXAS.0-30	LXAS.0-30	LXAS.0-30	GW14.3-BAT-LV-G10	LXU.5.0-30	LXAS.0-10 LXAS.0-30 LXU.5.0-30	LXAS.0-10 LXAS.0-30 GW14.3-BAT-LV-G10	LXAS.0-10/LXAS.0-30 GW14.3-BAT-LV-G10 LXU.5.0-30	
Tools	M4 1.4N·m M6 6N·m	M6 6N·m M5 4N·m	M4 1.4N·m M6 6N·m	M6 6N·m M5 4N·m	M5 4N·m M10 15N·m M5 4N·m	M5 4N·m M5 4N·m M5 4N·m	M6 6N·m M8 1.2N·m M10 15N·m		
Steps	1 Installation		2 Cable Connections		3 Power	4 Commissioning			
Smart meter	GMK110 GM330	GMK110	GM330	GM330	AC breaker	QR code 1	SolarGo APP	QR code 2 SEMS Portal APP or SEMS Portal WEB	

## 5.2 Installation Requirements

### 5.2.1 Installation Environment Requirements

1. Do not install the equipment in a place near flammable, explosive, or corrosive materials.
2. The temperature and humidity at the installation site should be kept within the appropriate range.
3. Keep away from children.

4. When the equipment is working, its temperature may exceed 60 °C. Do not touch the surface to avoid burn.
5. Install the equipment in a sheltered place to avoid direct sunlight, rain, and snow. Build a sunshade if it is needed.
6. The place to install the equipment shall be well-ventilated for heat radiation and large enough for operations.
7. Check the protection rating of the equipment and ensure that the installation environment meets the requirements. The inverter, battery system, and smart dongle can be installed both indoors and outdoors, but the smart meter can only be installed indoors.
8. Install the equipment at a height that is convenient for operation and maintenance, electrical connections, and checking indicators and labels.
9. The altitude to install the inverter shall be lower than the maximum working altitude of the system.
10. Consult the manufacturer before installing the equipment outdoors in salt affected areas. A salt-affected area refers to the region within 500 meters offshore, and will be related to the sea wind, precipitation and topography.
11. Install the equipment away from electromagnetic interference. If there is any radio or wireless communication equipment below 30MHz near the equipment, you have to:
  - Inverter: add a multi-turn winding ferrite core at the AC output cable of the inverter, or add a low-pass EMI filter. Or the distance between the inverter and the wireless EMI equipment should be more than 30m.
  - Other equipment: the distance between the equipment and the wireless EMI equipment should be more than 30m.
12. The length of the DC cable and communication cable between the battery and the inverter must be less than 3m. Please ensure that the installation distance between the inverter and the battery meets the cable length requirements.

#### NOTICE

If installed in an environment below 0°C, the battery will not be able to continue charging to restore energy after being discharged, resulting in undervoltage protection.

- LX A5.0-30, LX U5.0-30, GW14.3-BAT-LV-G10: Charging temperature range:  $0 < T \leq 55^{\circ}\text{C}$ ; Discharging temperature range:  $-20 < T \leq 55^{\circ}\text{C}$ .
- LX A5.0-10: Charging temperature range:  $0 < T \leq 50^{\circ}\text{C}$ ; Discharging temperature range:  $-10 < T \leq 50^{\circ}\text{C}$ .

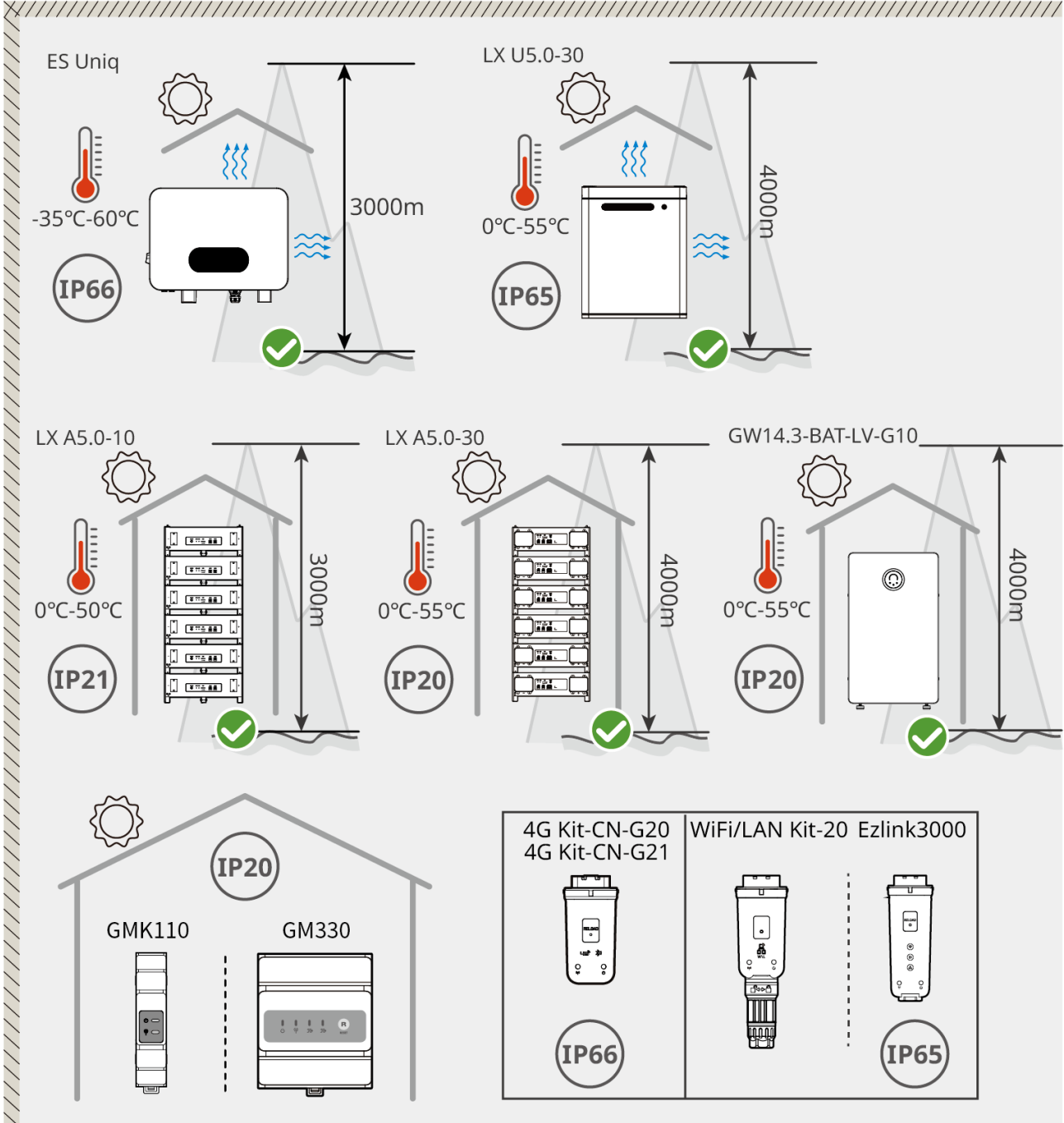

ESU10INT0012

## 5.2.2 Installation Space Requirements

Reserve enough space for operations and heat dissipation when installing the system. When using CAT7 communication cables among inverters, the maximum distance can reach 10 meters, while using CAT5 communication cables, the

maximum distance can reach 5 meters.

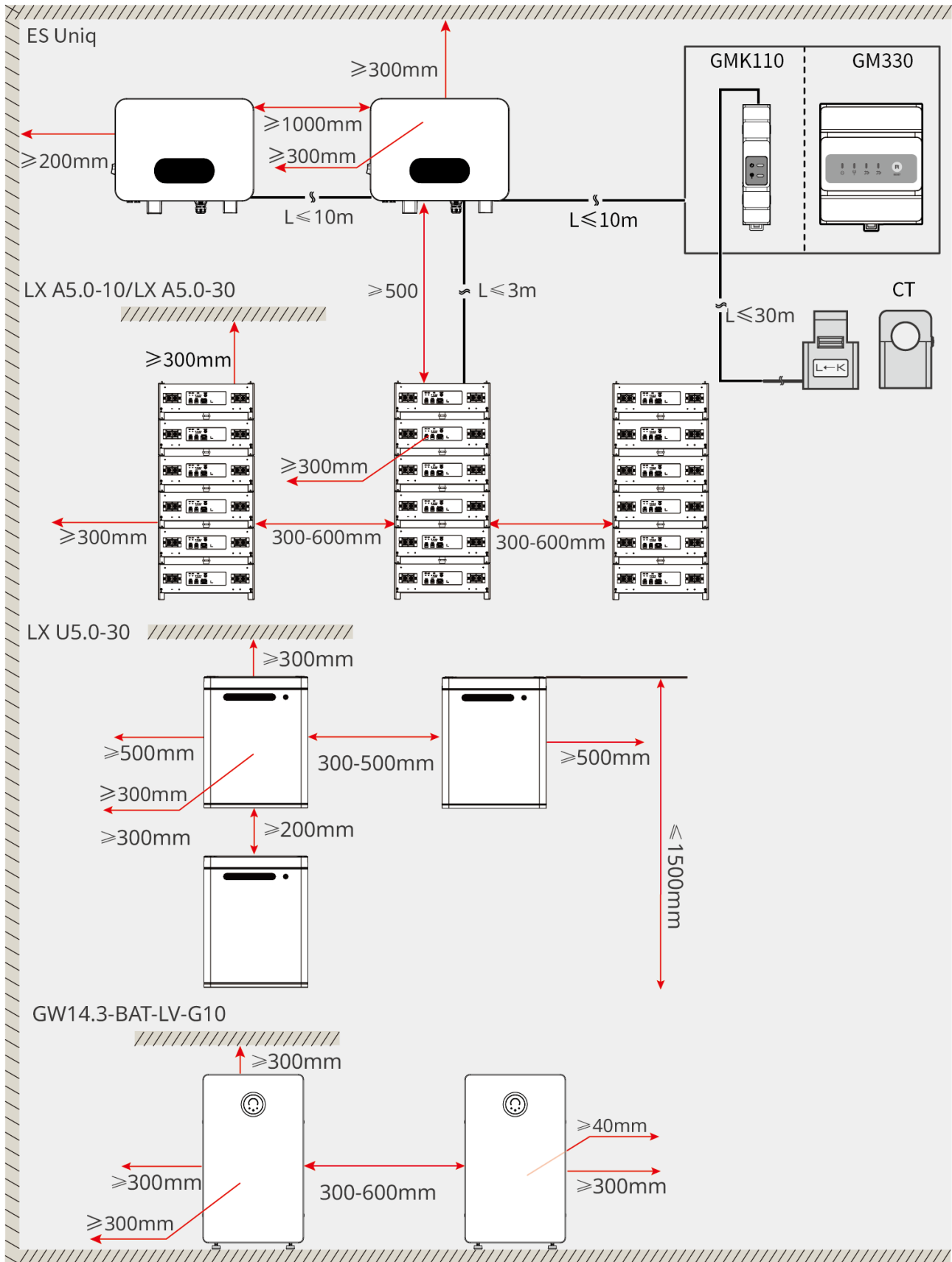

ESU10INT0013

## 5.2.3 Tool Requirements

### Notice

The following tools are recommended when installing the equipment. Use other auxiliary tools on site if necessary.

### Installation Tools

Tool Type	Description	Tool Type	Description
	Diagonal pliers		RJ45 crimping tool
	Wire stripper		Level ruler
	Adjustable wrench		PV connector tool A-2546B
	Impact drill (drill bits $\Phi 8\text{mm}$ )		Torque wrench M4/M5/M8
	Rubber hammer		Socket wrench set
	Marker		Multimeter Range $\leq 600\text{V}$
	Heat shrink tube		Heat gun
	Cable tie		Vacuum cleaner

### Personal Protective Equipment

Tool Type	Description	Tool Type	Description
	Insulating gloves and protective gloves		Dust mask
	Goggles		Safety shoes

## 5.3 Equipment Handling



 CAUTION

1. Operations such as transportation, turnover, installation and so on must meet the requirements of the laws and regulations of the country or region where inverters are installed.
2. Move the equipment to the site before installation. Follow the instructions below to avoid personal injury or equipment damage.
3. Please equip the corresponding personnel according to its weight, so that the equipment does not exceed the maximum weight that the personnel can carry to avoid personnel injuries.
4. Wear safety gloves to avoid personal injury.
5. Keep balance to avoid falling down when moving the equipment.
6. The battery system can be removed from the packaging box using a crane or hoist and transported to the installation site.
  - Crane requirements (GW14.3-BAT-LV-G10): Load capacity  $\geq$  180 kg
7. When moving equipment using a hoisting method, please use flexible slings or straps. The lifting rings and ropes for GW14.3-BAT-LV-G10 must meet the following requirements:
  - Suspension Ring: 4 M10 suspension rings, load capacity  $\geq$  260 kg
  - Suspension Rope: 1 suspension rope, rope length  $\geq$  2.5 m, suspension rope load capacity  $\geq$  600 kg

GW14.3-BAT-LV-G10:

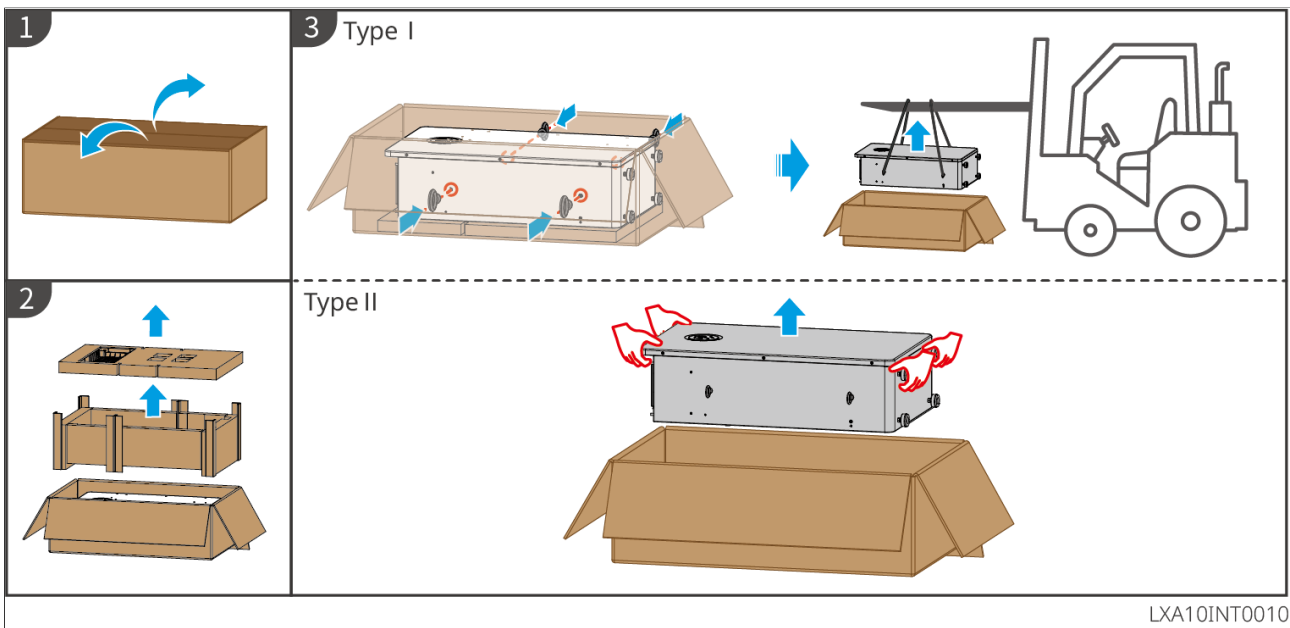

## 5.4 Installing the Inverter

### ⚠ CAUTION

- When drilling, ensure the hole position avoids water pipes, cables, etc. inside the wall to prevent danger.
- When punching holes, wear goggles and a dust mask to prevent dust from inhalation entering the respiratory tract or falling into the eyes.
- Ensure the inverter is securely mounted to prevent falling and causing injury.

1. Place the mounting plate horizontally on the wall and use a marker to mark the drilling positions.
2. Use hammer drill for punching.
3. Use expansion bolt to secure the Inverter mounting plate bracket to the wall.
4. Mount the Inverter onto the backplate. After mounting, secure the backplate and Inverter using screws to ensure the Inverter Installation is stable.

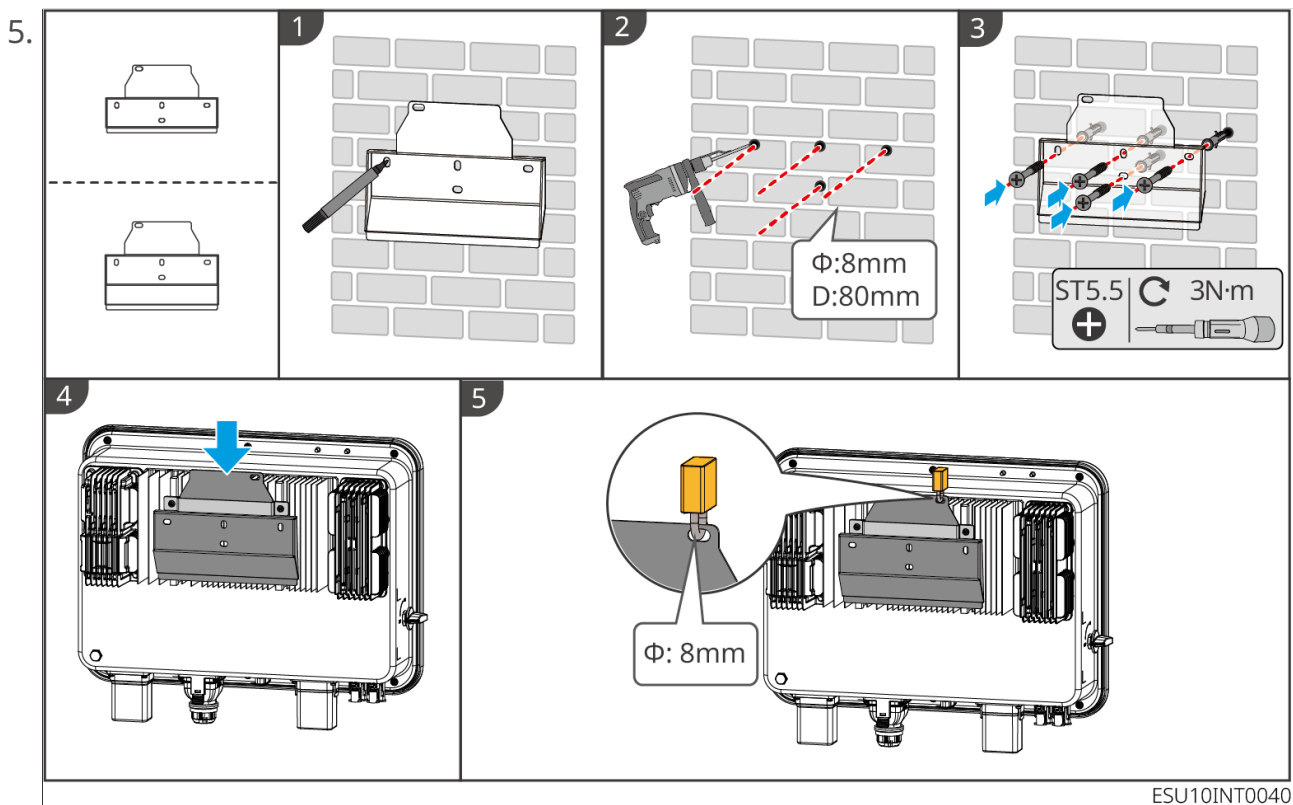

## 5.5 Installing the Battery System

### ⚠ WARNING

- Ensure that the battery system is installed vertically and securely. When using the locking bracket, the bracket should be vertically attached to the wall and the surface of the battery system.
- Cover the equipment with a cardboard to prevent foreign matters when drilling holes. Otherwise, the system may be damaged.
- After marking the drilling position with a marker pen, the battery system needs to be moved away to avoid equipment damage caused by the impact drill when drilling.

LX A5.0-30: Stacking installation

### NOTICE

Up to 6 batteries can be stacked.

1. Place the battery vertically, and remove the battery handles.
2. Install brackets on the battery, and secure them with screws.
3. Place the battery flat and stack multiple batteries. Ensure that the locating pin is inserted into the locating hole.

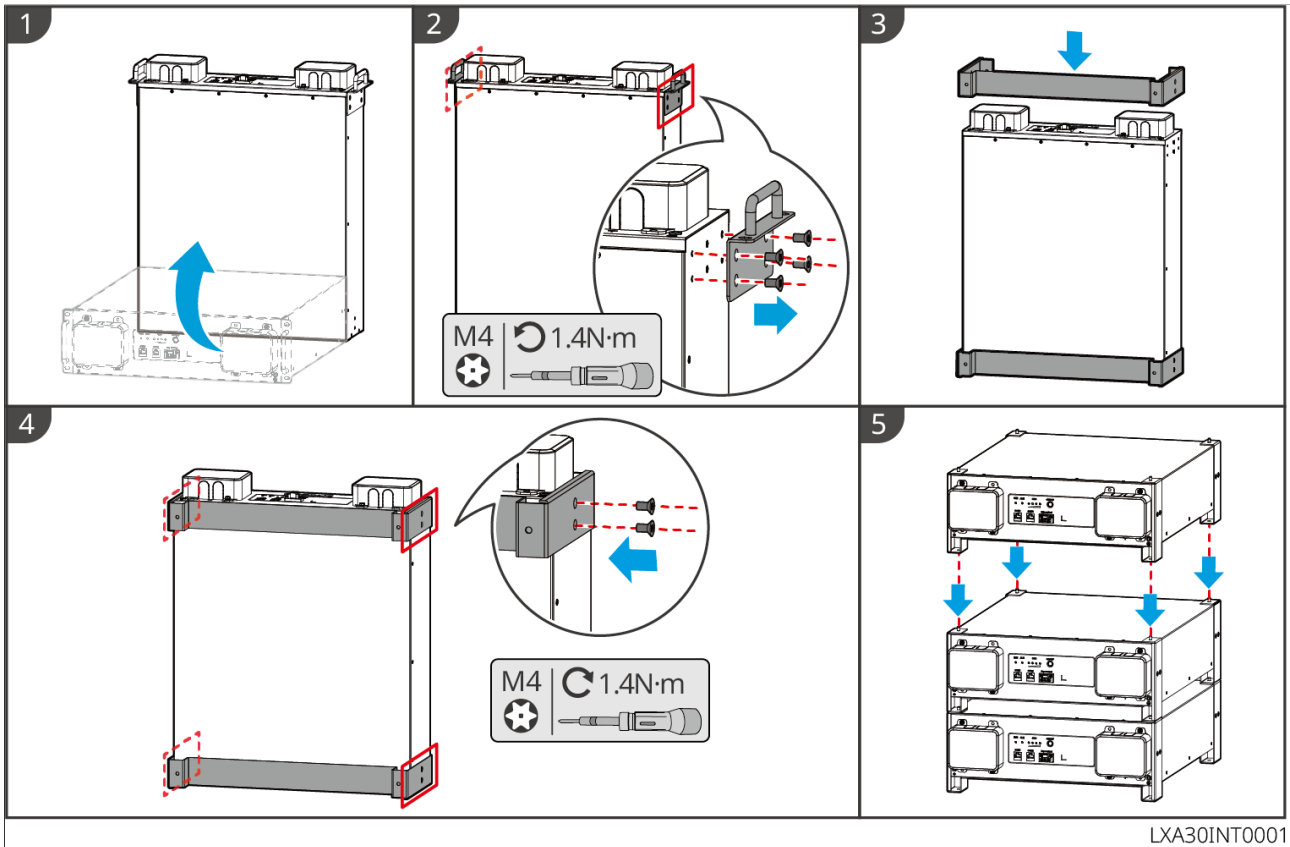

## LX A5.0-30: Cabinet Installation

### NOTICE

- It is recommended to install it in a 19-inch standard cabinet with a length \* width of 600\*800mm and above, and the height should be determined based on the thickness of the battery (133mm) and above.
- For cabinet installation, electrical labels and warning labels need to be attached to any position of the front panel of the battery (these labels are shipped as additional accessories).

1. Place the battery on the guide rail of the rack and secure the battery to the rack with screws from the handle. \

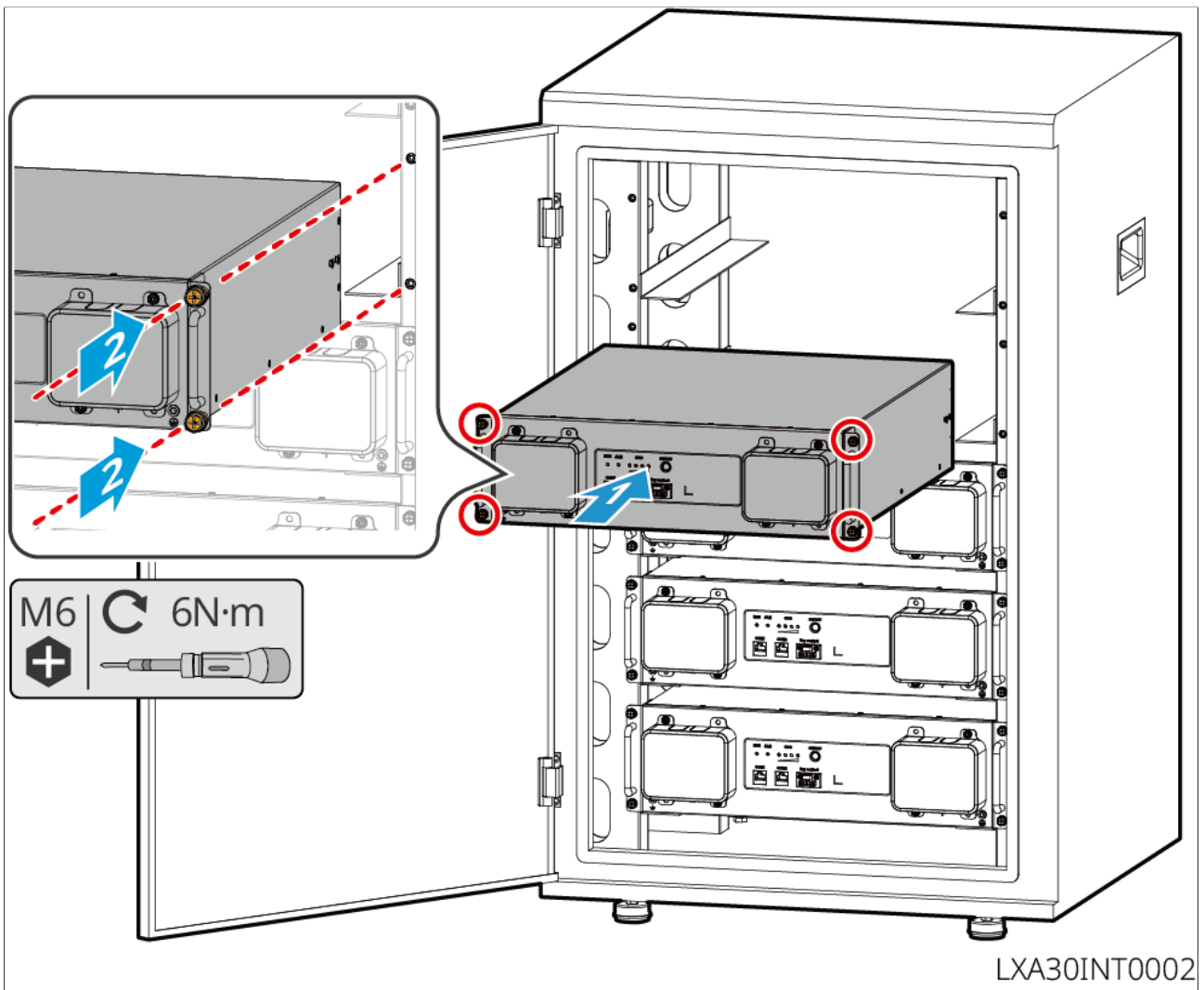

### LX A5.0-30: Wall-mounted Installation

1. Determine the drilling position with installation positioning cardboard and marker pen.
2. Use an impact drill to drill holes.
3. Install the battery brackets.
4. Install the battery on the brackets and use screws to secure the battery.

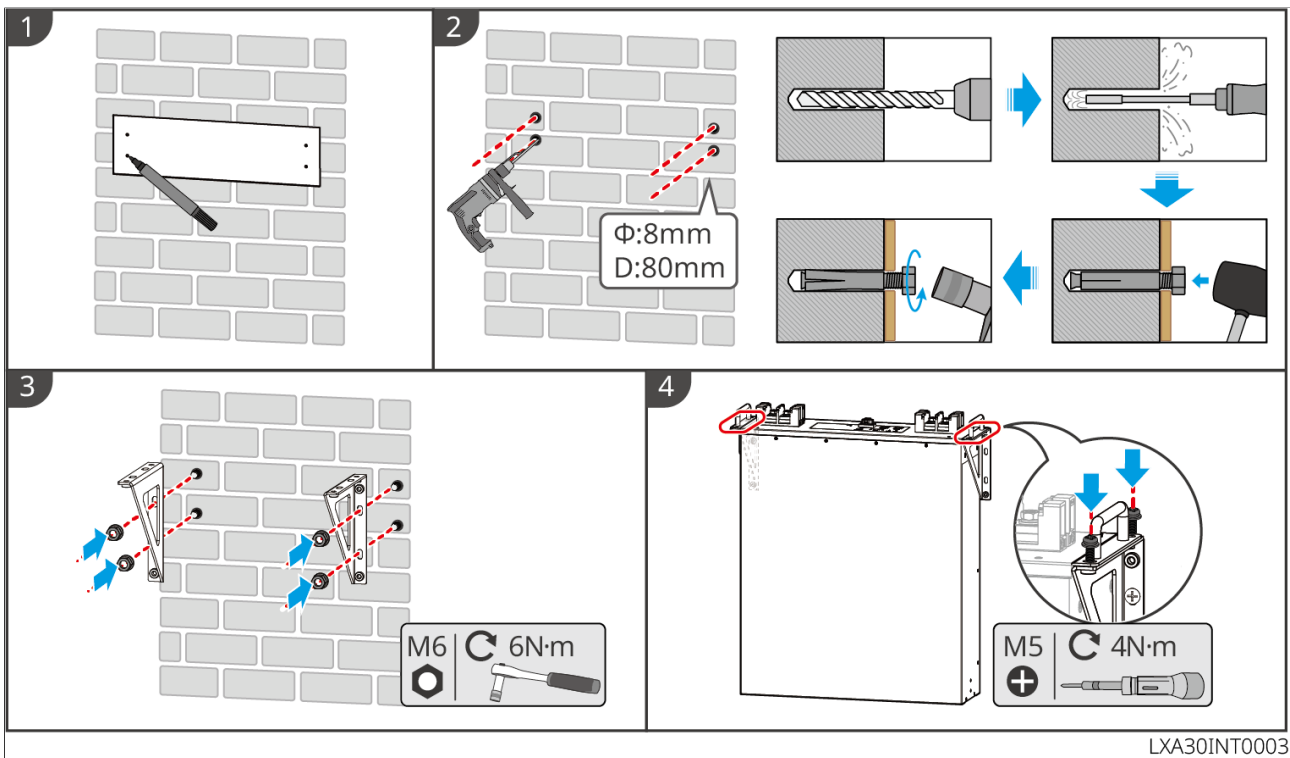

LXA30INT0003

## LX A5.0-10: Stacking installation

### NOTICE

Up to 6 batteries can be stacked for floor-mounted installation.

1. Place the battery vertically.
2. Install the bracket on the bottom of the battery, and then remove the handles from the battery.
3. Install another bracket on the battery.
4. Use screws to tight the brackets, then place the battery flatly.
5. Stack multiple batteries.
  - Insert locating pin on the bracket into locating hole. Align the positioning pins on the lower battery bracket with the positioning holes on the upper battery bracket.

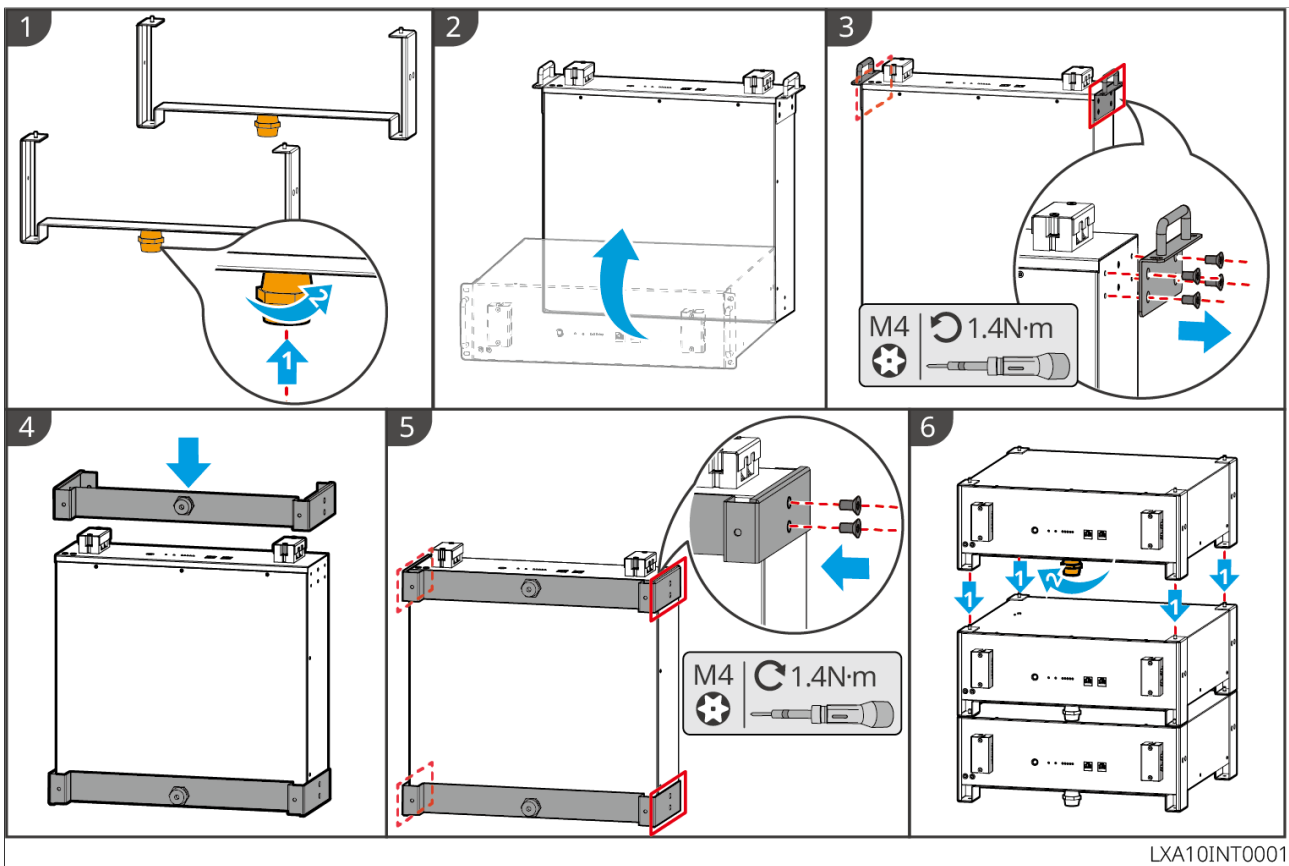

LXA10INT0001

## LX A5.0-10: Cabinet Installation

### NOTICE

- It is recommended to use a 19-inch standard cabinet with physical length and width of 600\*800mm and above. The height can be chosen according to the number of batteries in parallel.
- For cabinet installation, electrical labels and warning labels need to be attached to any position of the front panel of the battery (these labels are shipped as additional accessories).

1. Stick the electrical label and warning label to the position of the front panel of any battery.
2. Place the battery on the guide rail of the rack and secure the battery to the rack with screws from the handle.

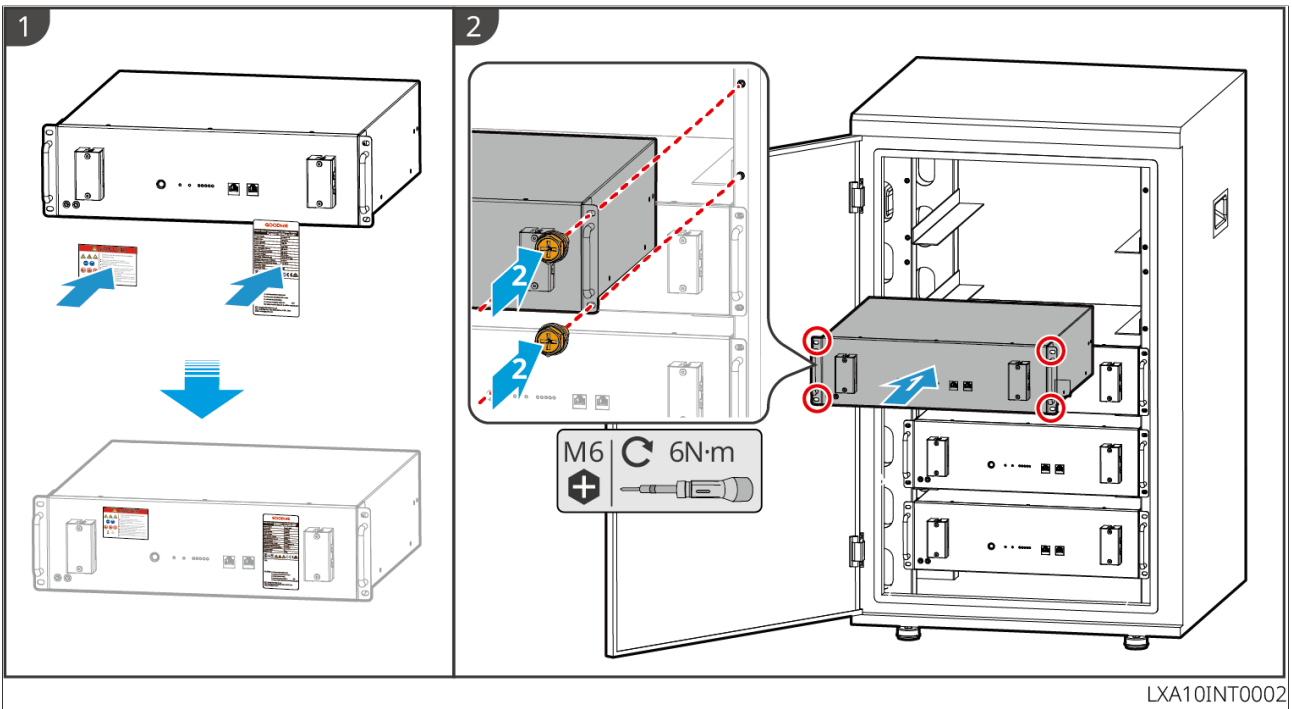

### LXU 5.0-30: Floor-mounted Installation

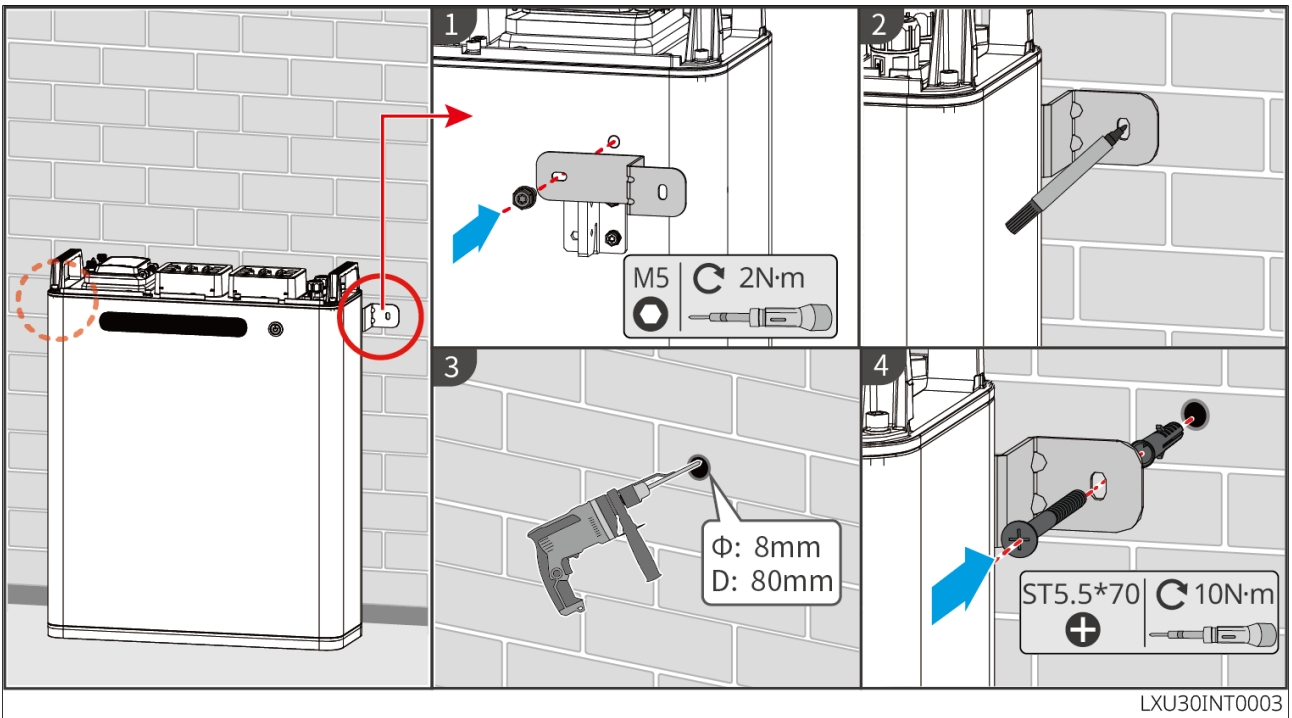

### LXU 5.0-30: Wall-mounted Installation



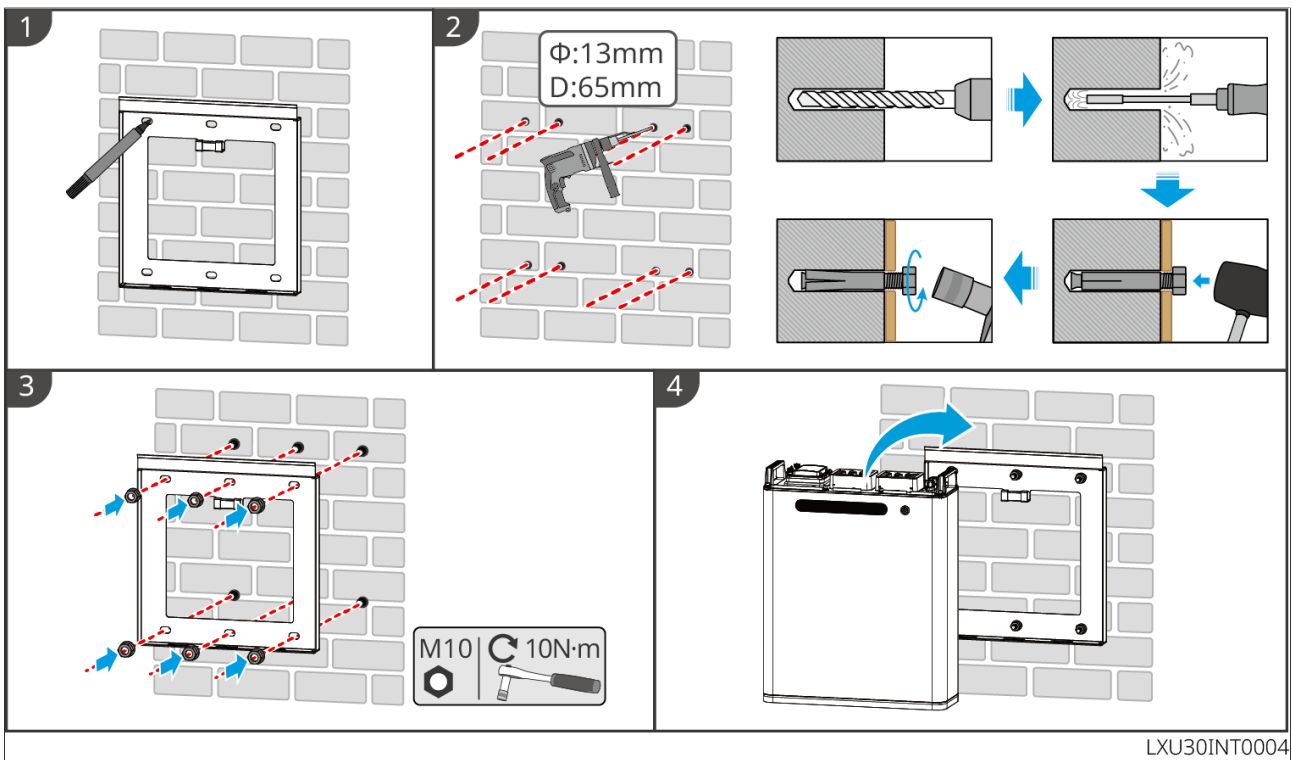

### 5.5.1 LX A5.0-30

LX A5.0-30: Stacking installation

#### NOTICE

Up to 6 batteries can be stacked.

1. Place the battery vertically, and remove the battery handles.
2. Install brackets on the battery, and secure them with screws.
3. Place the battery flat and stack multiple batteries. Ensure that the locating pin is inserted into the locating hole.

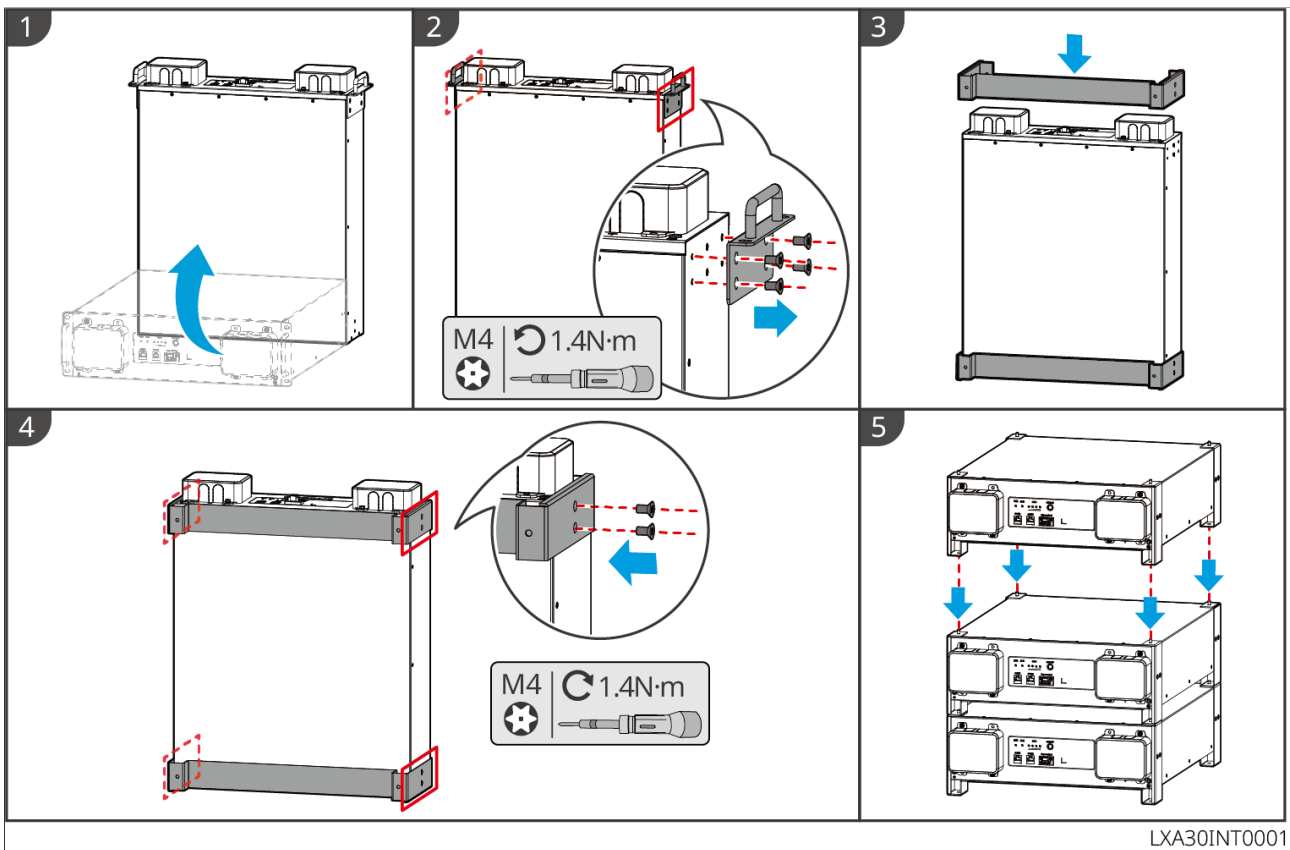

## LX A5.0-30: Cabinet Installation

### NOTICE

- It is recommended to install it in a 19-inch standard cabinet with a length \* width of 600\*800mm and above, and the height should be determined based on the thickness of the battery (133mm) and above.
- For cabinet installation, electrical labels and warning labels need to be attached to any position of the front panel of the battery (these labels are shipped as additional accessories).

1. Place the battery on the guide rail of the rack and secure the battery to the rack with screws from the handle.

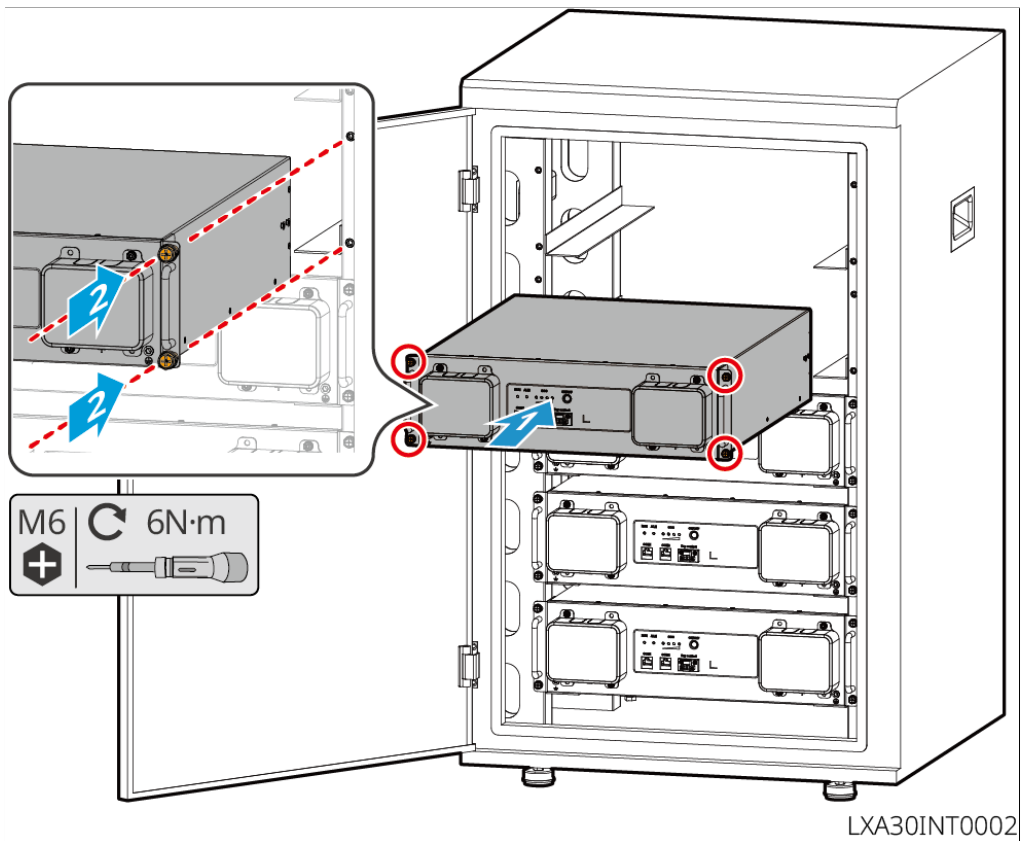

### LX A5.0-30: Wall-mounted Installation

1. Determine the drilling position with installation positioning cardboard and marker pen.
2. Use an impact drill to drill holes.
3. Install the battery brackets.
4. Install the battery on the brackets and use screws to secure the battery.

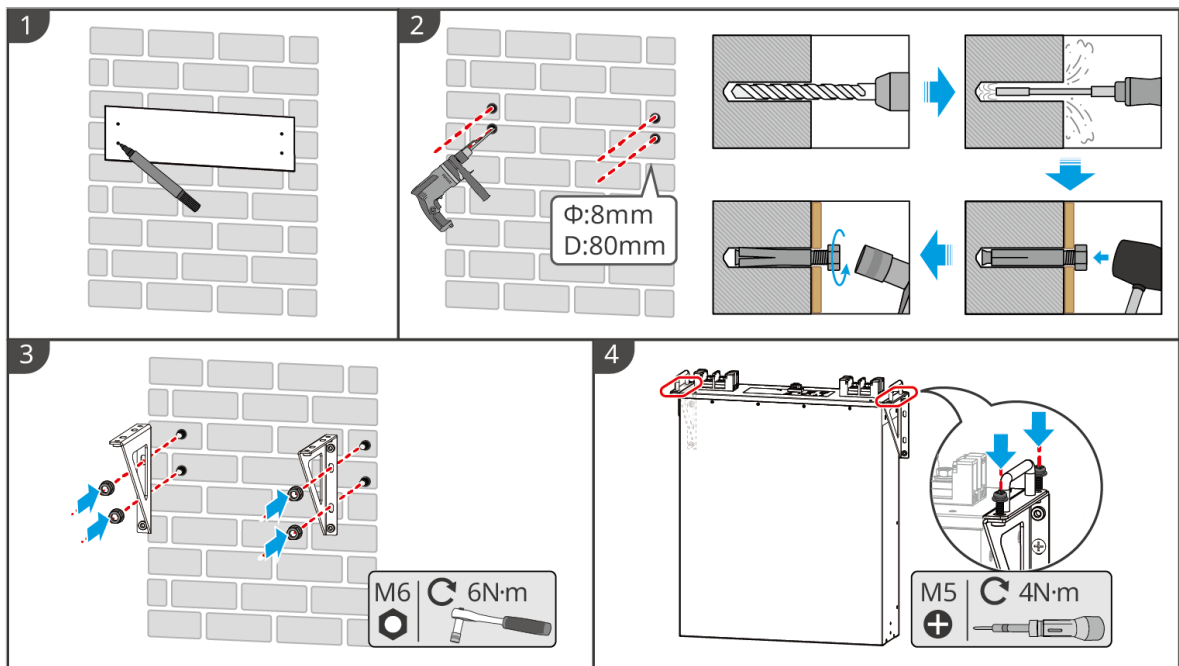

LXA30INT0003

## 5.5.2 LX A5.0-10

LX A5.0-10: Stacking installation

### NOTICE

Up to 6 batteries can be stacked for floor-mounted installation.

1. Place the battery vertically.
2. Install the bracket on the bottom of the battery, and then remove the handles from the battery.
3. Install another bracket on the battery.
4. Use screws to tight the brackets, then place the battery flatly.
5. Stack multiple batteries.
  - Insert locating pin on the bracket into locating hole. Align the positioning pins on the lower battery bracket with the positioning holes on the upper battery bracket.

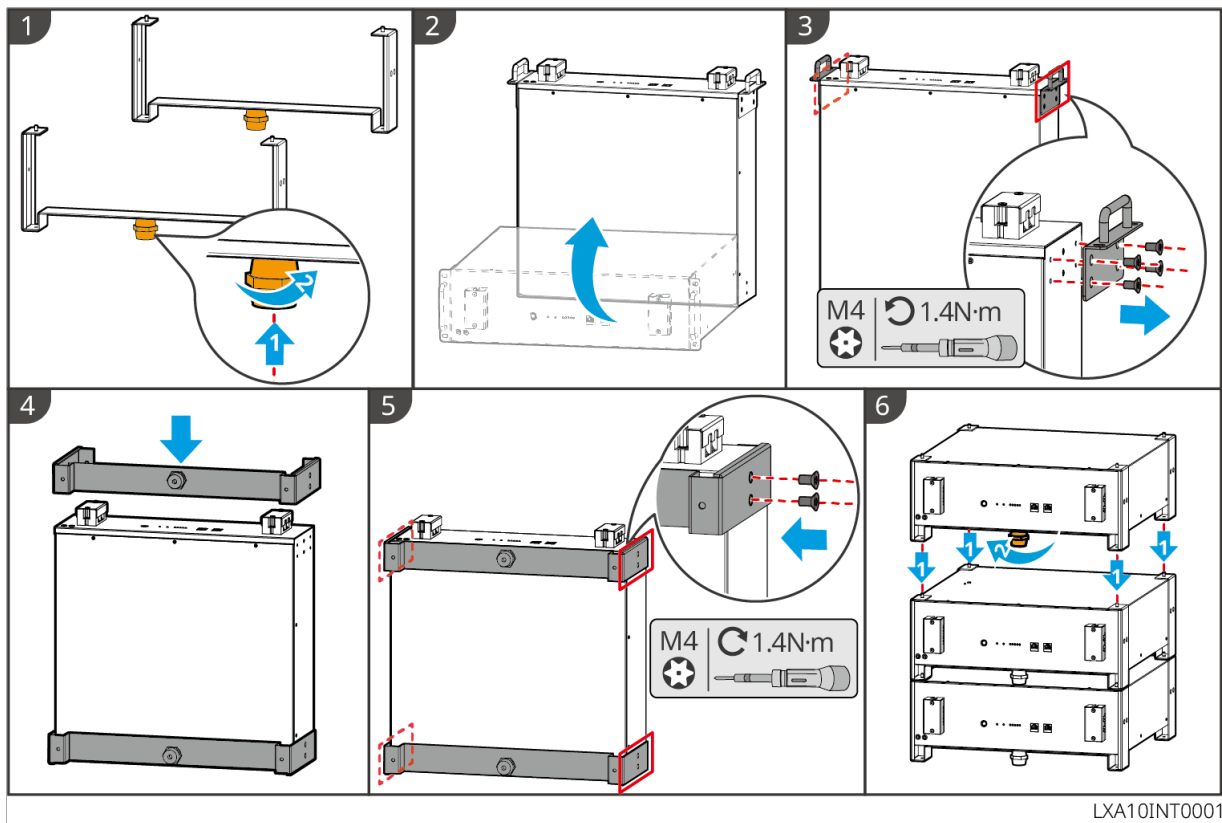

## LX A5.0-10: Cabinet Installation

### NOTICE

- It is recommended to use a 19-inch standard cabinet with physical length and width of 600\*800mm and above. The height can be chosen according to the number of batteries in parallel.
- For cabinet installation, electrical labels and warning labels need to be attached to any position of the front panel of the battery (these labels are shipped as additional accessories).

1. Stick the electrical label and warning label to the position of the front panel of any battery.
2. Place the battery on the guide rail of the rack and secure the battery to the rack with screws from the handle.

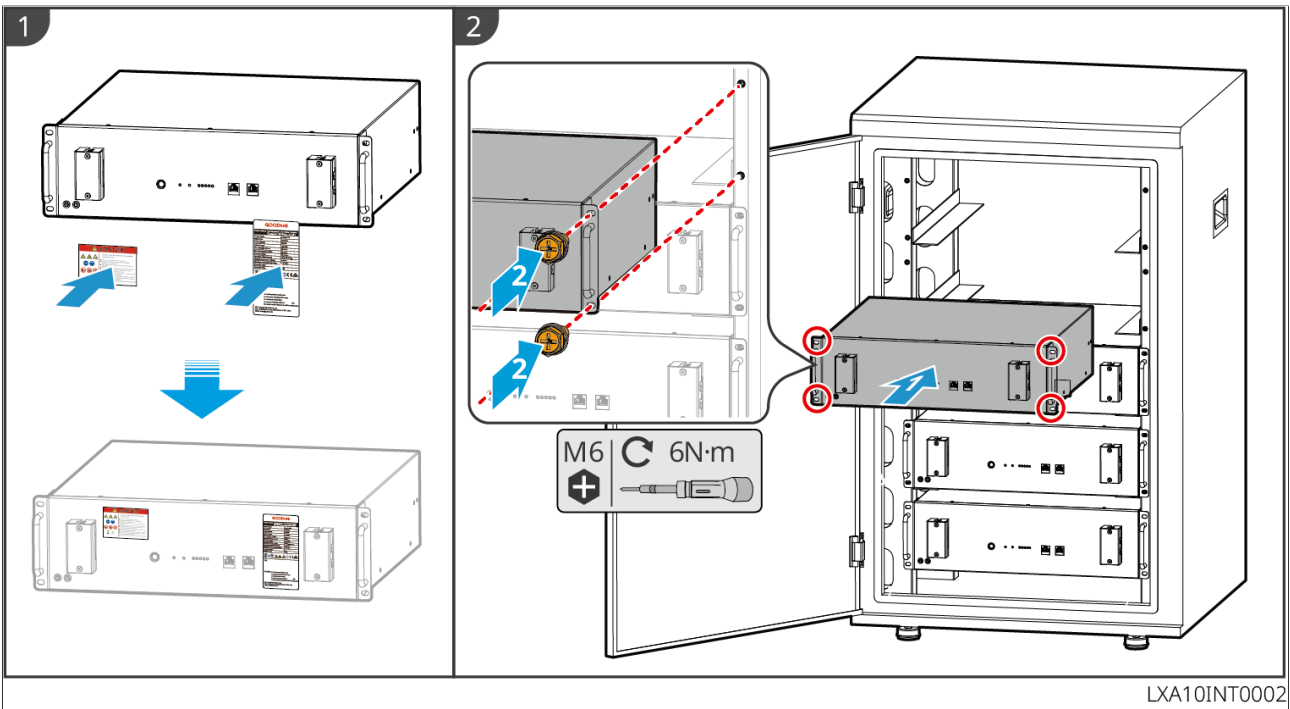

### LX A5.0-10: Wall-mounted Installation

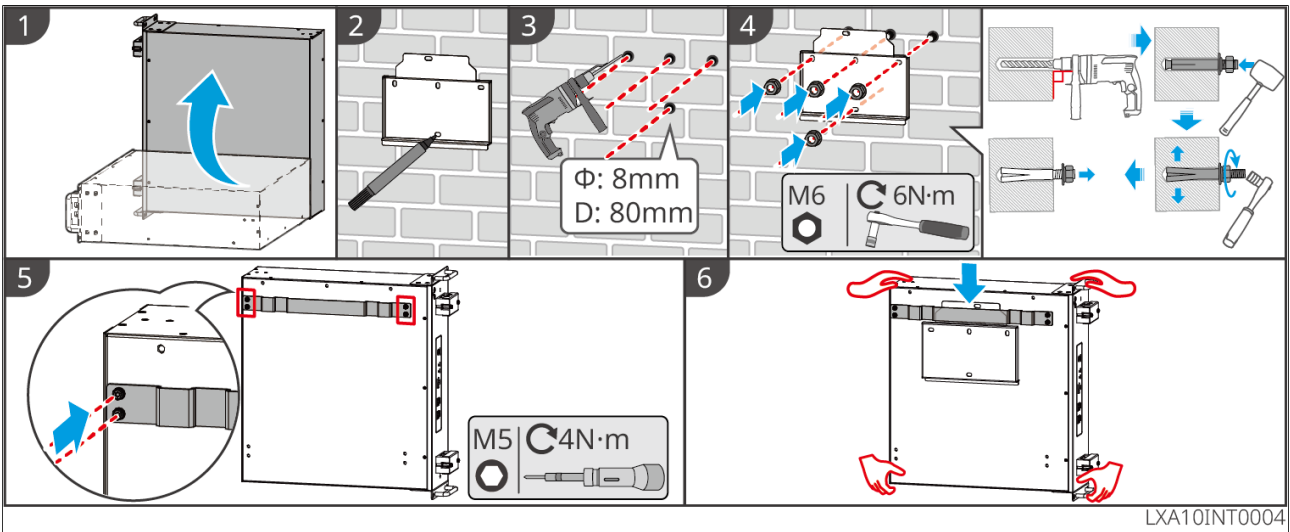

### 5.5.3 LX U5.0-30

#### LX U5.0-30: Floor-mounted Installation

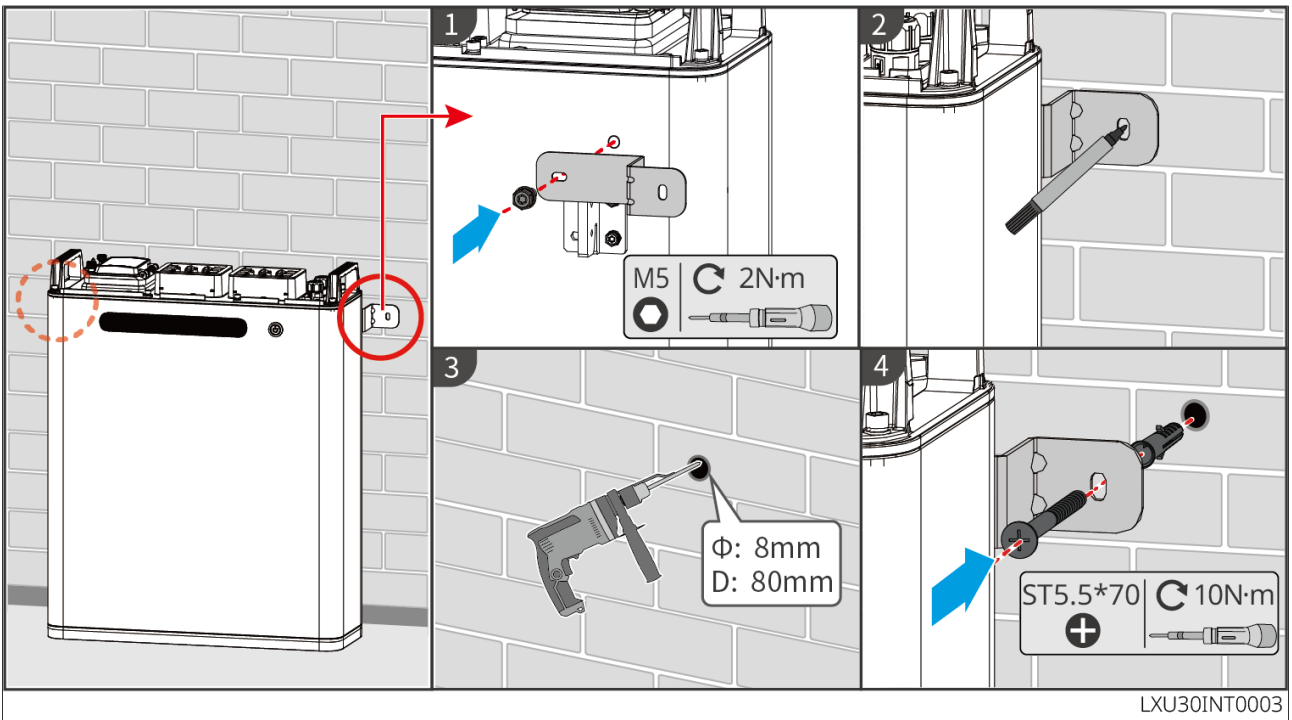

LX U5.0-30: Wall-mounted Installation

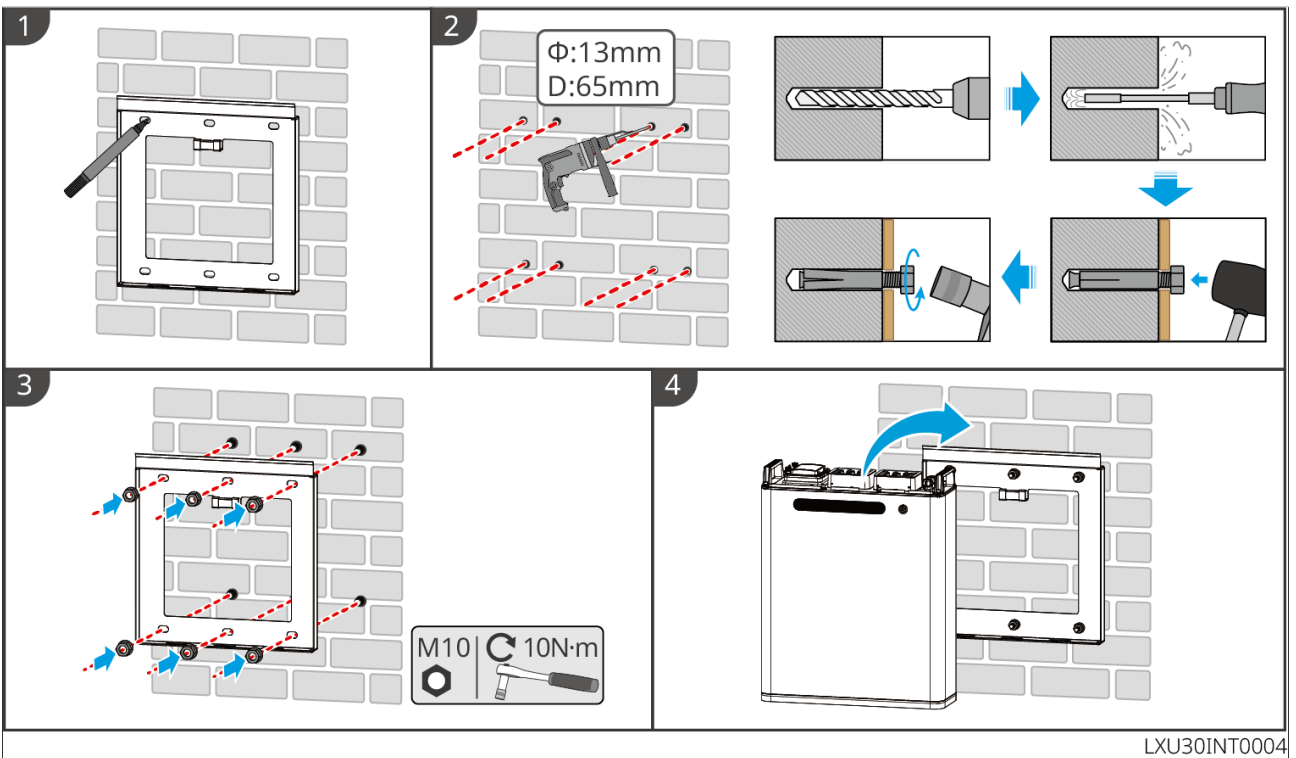

5.5.4 GW14.3-BAT-LV-G10

## NOTICE

- Wall mounting requires two people.

### GW14.3-BAT-LV-G10: Floor-mounted installation

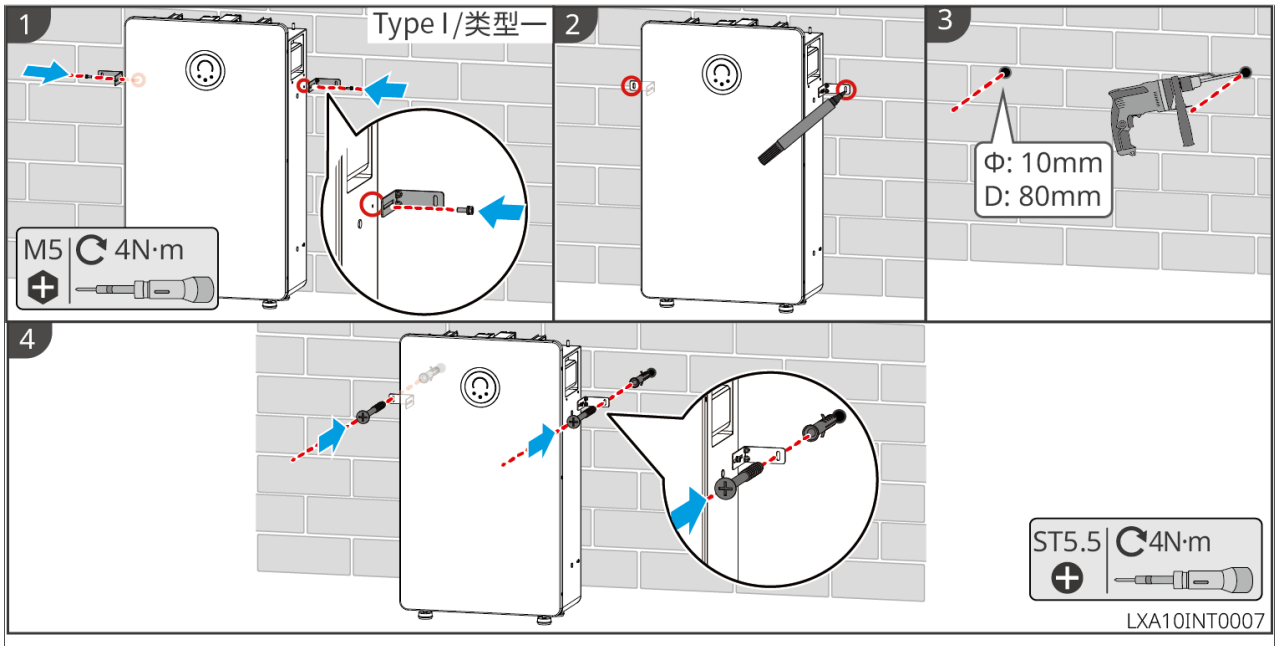

### GW14.3-BAT-LV-G10: Wall-mounted Installation



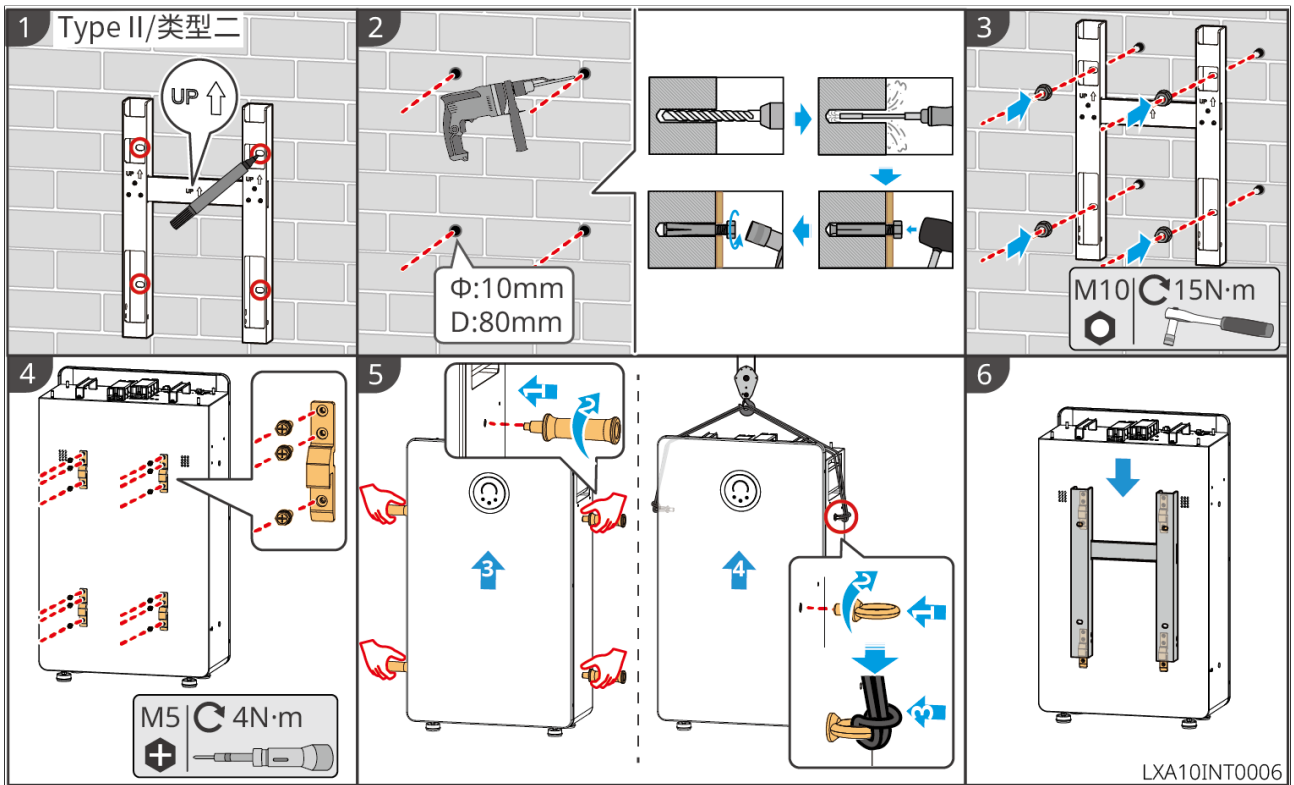

## 5.6 Installing the Smart Meter

### ⚠ WARNING

In areas at risk of lightning, if the meter cable exceeds 10m and the cables are not wired with grounded metal conduits, you are recommended to use an external lightning protection device.

GMK110

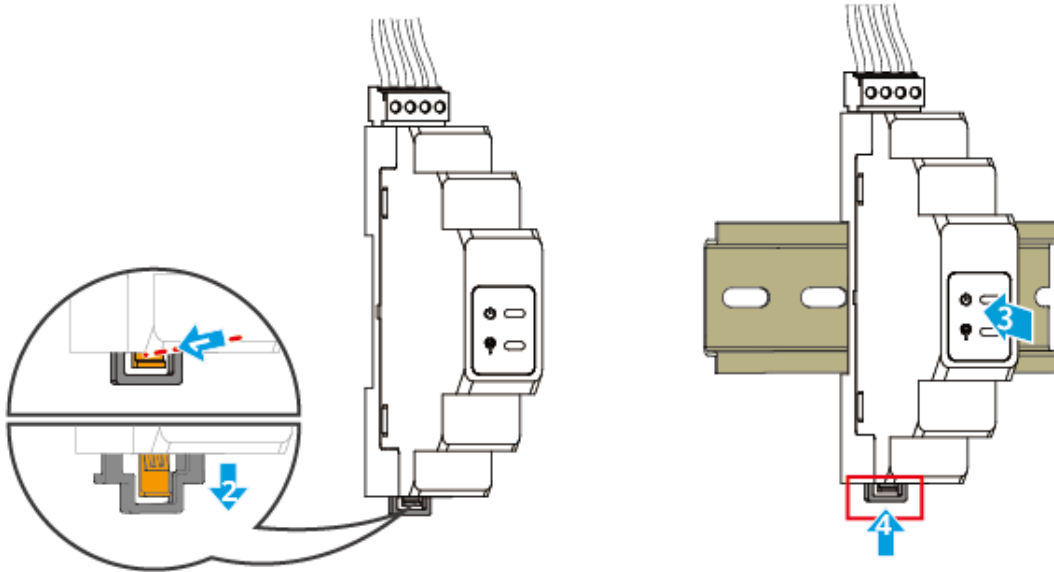

GM330

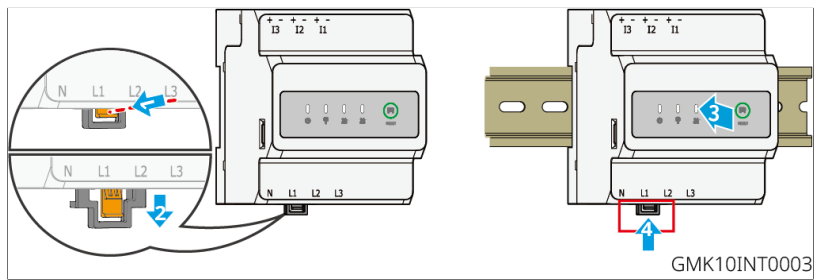

## 6 System Wirings

### DANGER

- The erection, routing, and connection of cables must be in compliance with local laws and regulations.
- Perform electrical connections in compliance with local laws and regulations, including operations, cables, and component specifications.
- Disconnect the DC switches and the AC output switches to power off the equipment before any electrical connections. Do not work with power on. Otherwise, an electric shock may occur.
- Tie the same type cables together, and place them separately from cables of different types. Do not place the cables entangled or crossed.
- If the cable bears too much tension, the connection may be poor. Reserve a certain length of the cable before connecting it to the inverter cable port.
- Make sure that the cable conductor is in full contact with the terminal and the cable insulation part is not crimped with the terminal when crimping the terminal. Otherwise, the device may not be able to work properly, or the connection may be unreliable during working, which may cause terminal block damage, etc..

### NOTICE

- Wear personal protective equipment like safety shoes, safety gloves, and insulating gloves during electrical connections.
- All electrical connections should be performed by qualified professionals.
- Cable colors in this document are for reference only. The cable specifications shall meet local laws and regulations.
- For parallel systems, follow the safety precautions in the user manuals of related products in the system.

### 6.1 System Wiring Electrical Block Diagram

### NOTICE

- N and PE wiring of ON-GRID and BACK-UP ports of the inverter are different according to the regulation requirements of different regions. Refer to the specific requirements of local regulations.
- The inverter features built-in relays for the ON\_GRID and BACK\_UP AC ports. When the inverter is in off-grid mode, the built-in ON\_GRID state relay is disconnected; when the inverter is in on-grid operation mode, the built-in ON-GRID relay is connected.
- When the inverter is powered on, the BACK-UP AC port is energized. Power off the inverter first if maintenance is required on the BACK-UP loads. Otherwise, it may cause electric shock.

N and PE cables are separately wired in the Main Panel

#### NOTICE

- Ensure that the grounding of BACK-UP is correctly tightened. Otherwise, the BACK-UP function may be abnormal in case of grid failure.
- The following diagram is applicable to areas except Australia or New Zealand.

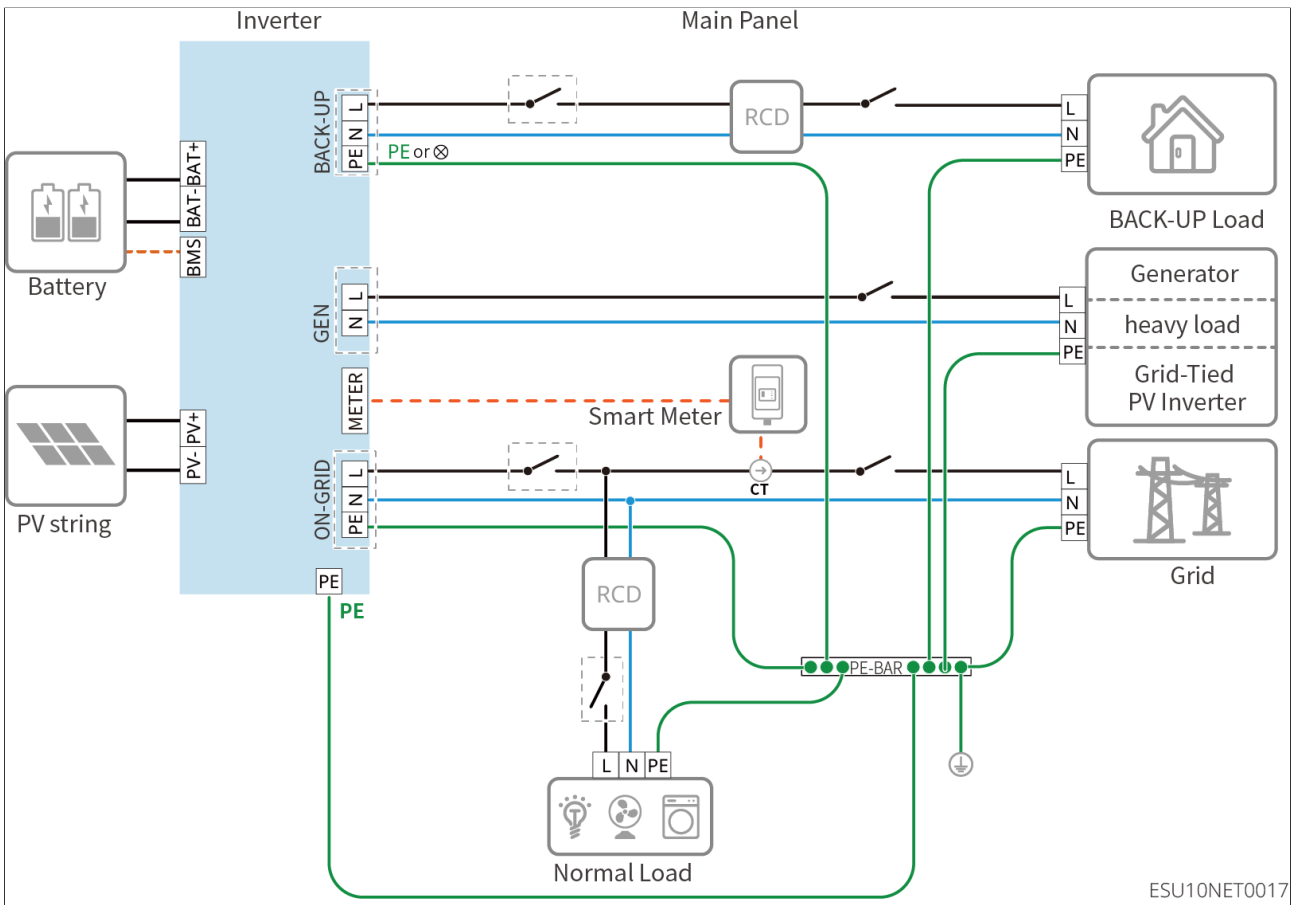

ESU10NET0017

## 6.2 Detailed System Wiring Diagram

### 6.2.1 Detailed System Wiring Diagram for Single Inverter

GM330 and other meters that meet the requirements can also be used in single inverter scenarios. Only the recommended types are shown here:

With built-in smart meter

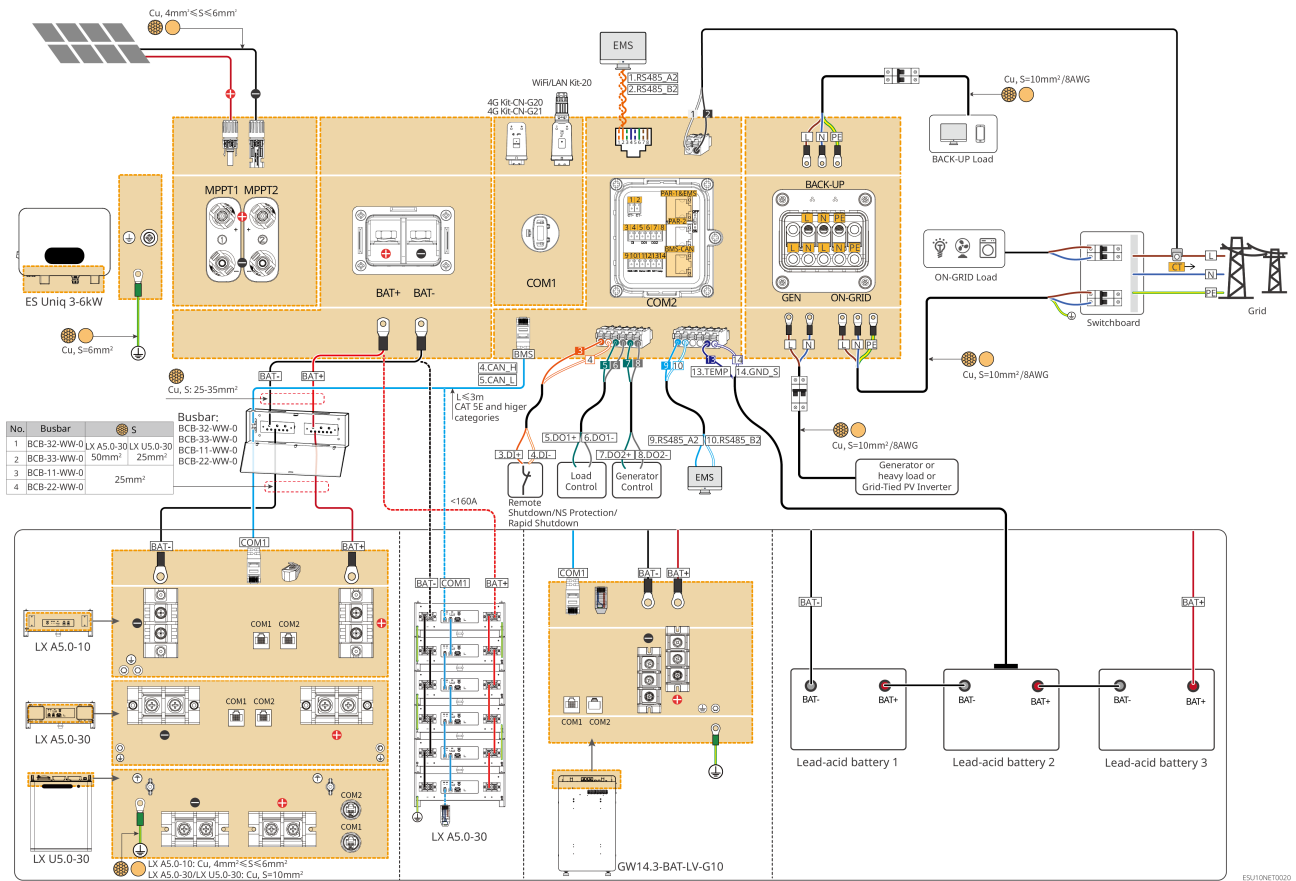

Use GM110 in the system

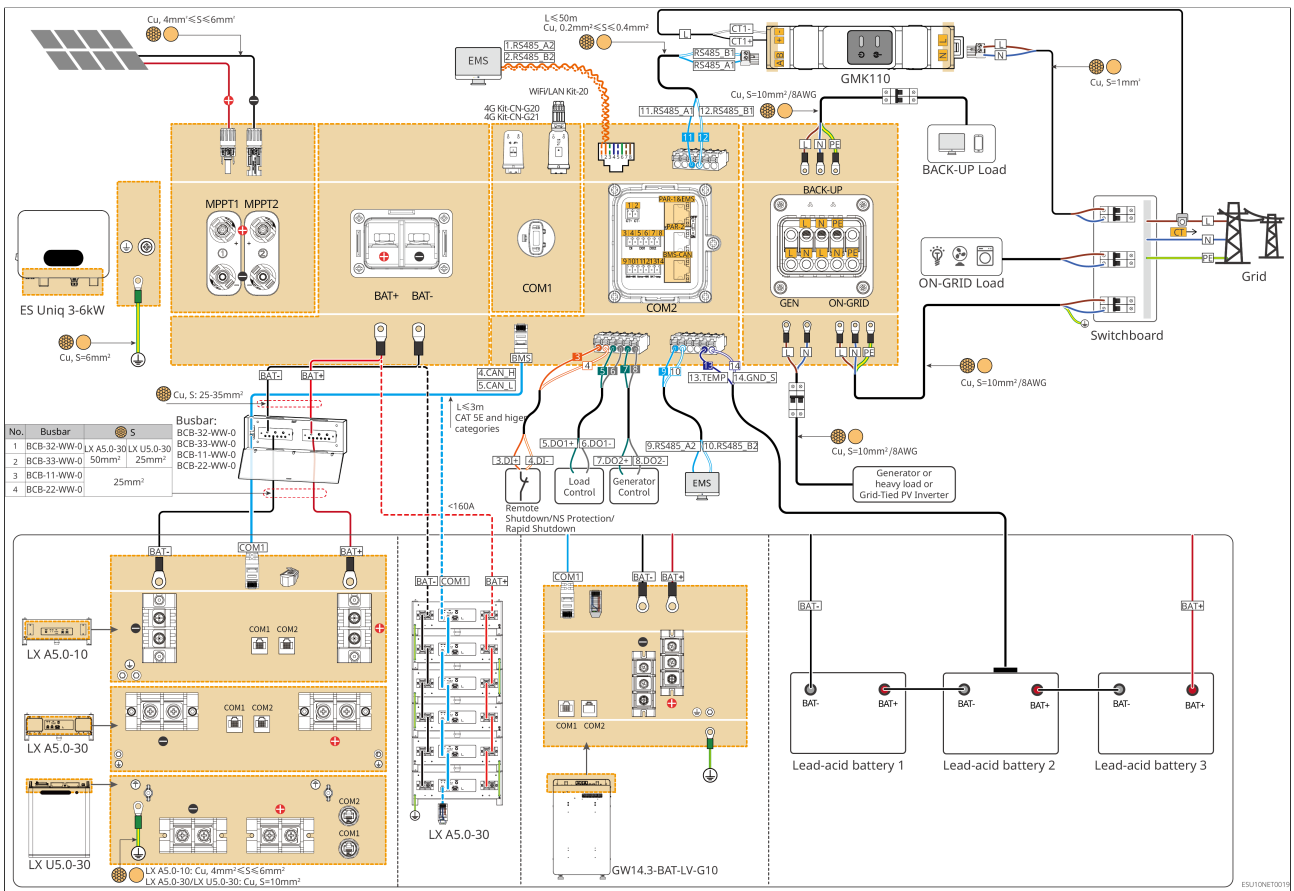

## 6.2.2 Detailed System Wiring Diagram for Parallel System

- In parallel scenarios, the inverter connected to the Ezlink and smart meter is considered as the master inverter, while all the others are slave inverters. Do not connect any smart dongle to the slave inverters.
- Generator, large loads and grid-tied PV inverter are not supported in parallel system.
- The following diagram mainly introduces parallel connections. For other port connections, refer to the single system.

Use GM330 in the system

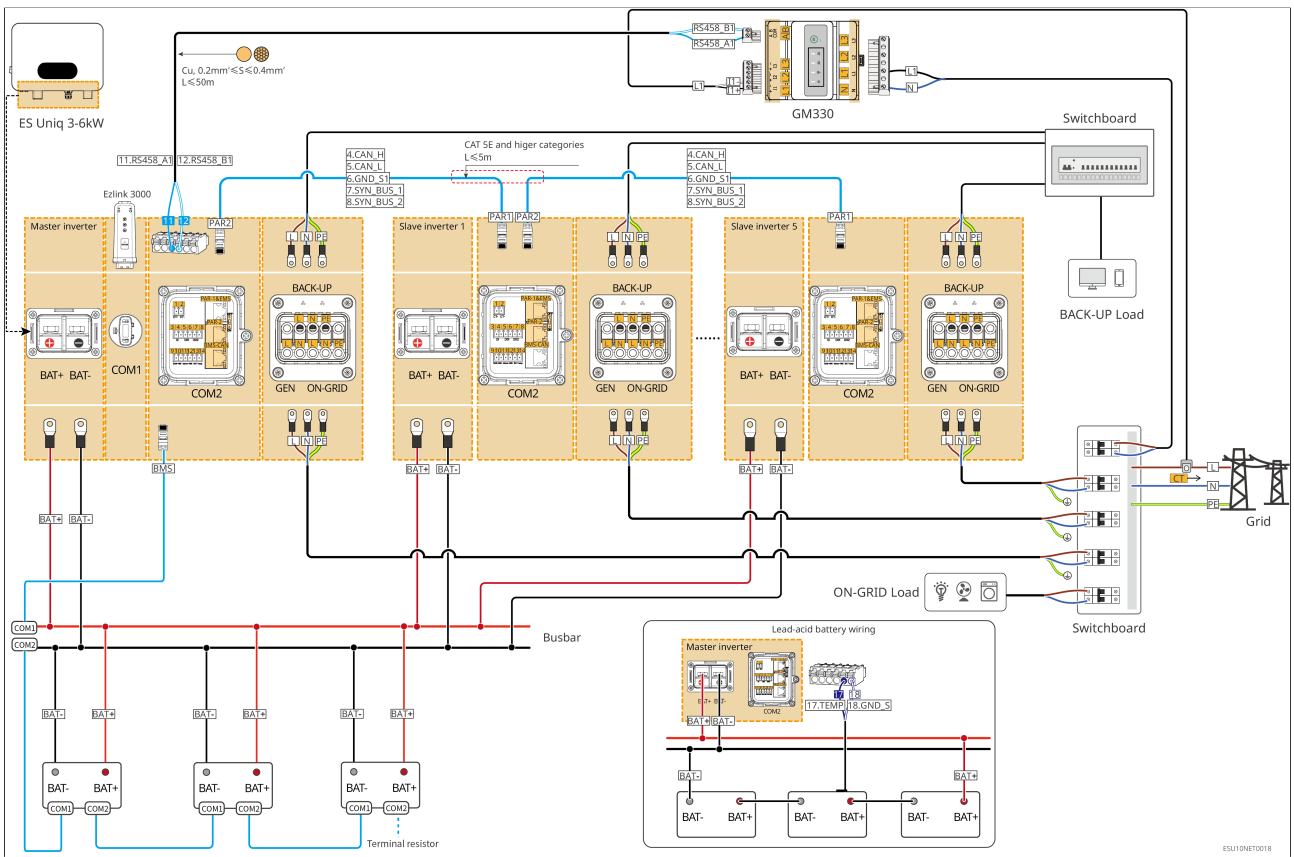

Use GM110 in the system



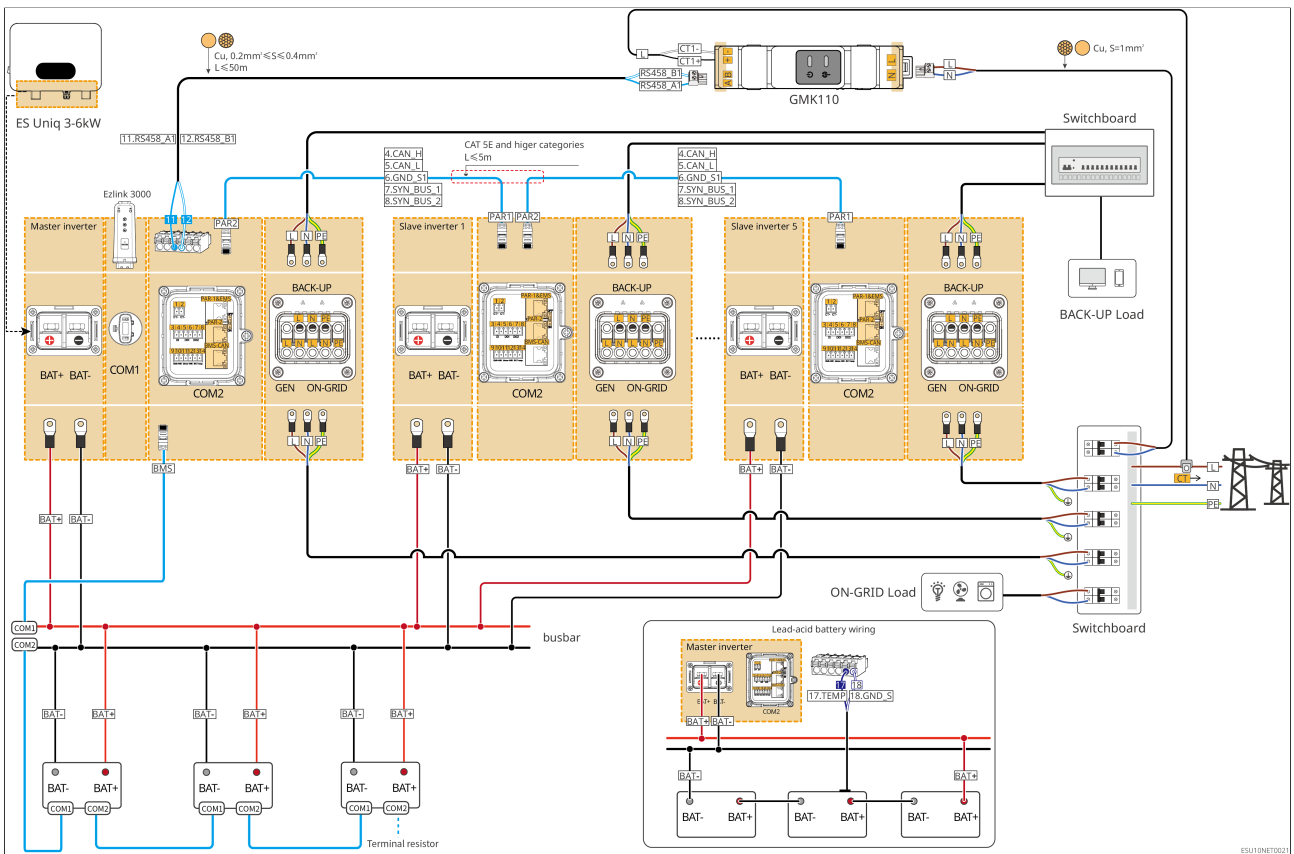

### 6.3 Preparing Materials



- Do not connect loads between the inverter and the AC switch that is directly connected to the inverter.
- Install one AC output circuit breaker for each inverter. Multiple inverters cannot share one AC circuit breaker.
- An AC circuit breaker shall be installed on the AC side to make sure that the inverter can be safely disconnected with the grid when an exception happens. Select the appropriate AC circuit breaker in compliance with local laws and regulations.
- When the inverter is powered on, the BACK-UP AC port is energized. Power off the inverter first if maintenance is required on the BACK-UP loads. Otherwise, it may cause electric shock.
- For cables used in the same system, it is recommended that the conductor material, cross sectional area, length, etc. of the cables should be consistent.
  - The AC cable for BACK-UP port of each inverter
  - The AC cable for ON-GRID port of each inverter
  - The power cable between inverter and battery
  - The power cable between batteries
  - The power cable between inverter and busbar
  - The power cable between battery and busbar

### 6.3.1 Preparing Breakers

No.	Circuit breaker	Recommended specifications	Comment
1	<ul style="list-style-type: none"> <li>• ON-GRID circuit breaker</li> <li>• BACK-UP load breaker</li> <li>• GEN breaker</li> </ul>	<ul style="list-style-type: none"> <li>• GW3000-ES-C10, GW3000-ES-C11, GW3600-ES-C10: nominal current <math>\geq 40A</math>, nominal voltage <math>\geq 230V</math></li> <li>• GW5000-ES-C10, GW6000-ES-C10: nominal current <math>\geq 50A</math>, nominal voltage <math>\geq 230V</math></li> </ul>	Prepared by customers.

No.	Circuit breaker	Recommended specifications	Comment
2	Battery breaker	<p>Optional in compliance with local laws and regulations</p> <ul style="list-style-type: none"> <li>• GW3000-ES-C10: nominal current <math>\geq 90A</math>, nominal voltage <math>\geq 60V</math></li> <li>• GW3000-ES-C11: nominal current <math>\geq 175A</math>, nominal voltage <math>\geq 60V</math></li> <li>• GW3600-ES-C10: nominal current <math>\geq 115A</math>, nominal voltage <math>\geq 60V</math></li> <li>• GW5000-ES-C10: nominal current <math>\geq 150A</math>, nominal voltage <math>\geq 60V</math></li> <li>• GW6000-ES-C10: nominal current <math>\geq 175A</math>, nominal voltage <math>\geq 60V</math></li> </ul>	Prepared by customers.
3	RCD	<p>Optional in compliance with local laws and regulations</p> <ul style="list-style-type: none"> <li>• Type A</li> <li>• ON-GRID RCD: 300mA</li> <li>• BACK-UP RCD: 30mA</li> </ul>	Prepared by customers.

### 6.3.2 Preparing Cables

No.	Cable	Recommended specifications	Acquisition method
1	Inverter PE cable	<ul style="list-style-type: none"> <li>• Single-core outdoor copper cable</li> <li>• Conductor cross-sectional area: <math>S=6\text{mm}^2</math></li> </ul>	Prepared by customers

No.	Cable	Recommended specifications	Acquisition method
2	Battery PE cable	<ul style="list-style-type: none"> <li>• Single-core outdoor copper cable</li> <li>• Conductor cross-sectional area:</li> <li>• LX A5.0-10: 4-6mm<sup>2</sup></li> <li>• LX A5.0-30: 10mm<sup>2</sup></li> <li>• LX U5.0-30: 10mm<sup>2</sup></li> <li>• GW14.3-BAT-LV-G10: 10mm<sup>2</sup></li> </ul>	<ul style="list-style-type: none"> <li>• Prepared by customers</li> <li>• LX A5.0-30, LX A5.0-10: Accessory acquisition (optional)</li> <li>• GW14.3-BAT-LV-G10: For some inverters, the grounding cables are shipped together with the battery accessories.</li> </ul>
3	PV DC cable	<ul style="list-style-type: none"> <li>• Commonly used outdoor photovoltaic cable</li> <li>• Conductor cross-sectional area: 4-6mm<sup>2</sup></li> <li>• Outer diameter: 4.8mm-6.3mm</li> </ul>	Prepared by customers

No.	Cable	Recommended specifications	Acquisition method
4	Battery DC cable	<ul style="list-style-type: none"> <li>• Single-core outdoor copper cable</li> <li>• Wiring requirements for inverter battery ports: <ul style="list-style-type: none"> <li>◦ Conductor cross-sectional area: 25-35mm<sup>2</sup></li> <li>◦ Outer diameter: 8-13mm</li> </ul> </li> <li>• Requirements for cables between battery and busbar: <ul style="list-style-type: none"> <li>◦ LX A5.0-30, conductor cross-sectional area: 50mm<sup>2</sup></li> <li>◦ LX (A5.0 -10, LX A5.0-30, conductor cross-sectional area: 25mm<sup>2</sup></li> <li>◦ GW14.3-BAT-LV-G10, conductor cross-sectional area: 70 mm<sup>2</sup></li> </ul> </li> <li>• Requirements for cables between batteries: <ul style="list-style-type: none"> <li>◦ LX A5.0-30, conductor cross-sectional area: 50mm<sup>2</sup></li> <li>◦ LX (A5.0 -10, LX A5.0-30, conductor cross-sectional area: 25mm<sup>2</sup></li> <li>◦ GW14.3-BAT-LV-G10, conductor cross-sectional area: 70 mm<sup>2</sup></li> </ul> </li> </ul>	<ul style="list-style-type: none"> <li>• Prepared by customers</li> <li>• LX U5.0-30: Supports purchase from GoodWe</li> <li>• LX A5.0-30, LX A5.0-10: Accessory acquisition (optional)</li> <li>• GW14.3-BAT-LV-G10: For some inverters, the battery DC cables are shipped together with the battery accessories.</li> </ul>

No.	Cable	Recommended specifications	Acquisition method
5	AC cable	<ul style="list-style-type: none"> <li>• AC input and output cables of inverter (BACKUP/ GRID):               <ul style="list-style-type: none"> <li>◦ Conductor Cross-sectional area: 10mm<sup>2</sup>/ 8AWG</li> <li>◦ Outer diameter of multi-core outdoor copper cable: 15-18mm</li> <li>◦ Outer diameter of single-core outdoor copper cable: 5.5mm-7mm</li> </ul> </li> <li>• Generator power cable (GEN):               <ul style="list-style-type: none"> <li>◦ Conductor Cross-sectional area: 10mm<sup>2</sup>/ 8AWG</li> <li>◦ Outer diameter of multi-core outdoor copper cable: 14mm-17mm</li> <li>◦ Outer diameter of single-core outdoor copper cable: 5.5mm-7mm</li> </ul> </li> </ul>	Prepared by customers
6	Smart meter power cable	<ul style="list-style-type: none"> <li>• Outdoor copper cable</li> <li>• Conductor Cross-sectional area: 1mm<sup>2</sup></li> </ul>	Prepared by customers
7	Battery communication cable	Communication between the combiner box and the battery, as well as between batteries, requires the use of CAT 5E and above standard shielded network cable and RJ45 shielded connector.	<ul style="list-style-type: none"> <li>• Prepared by customers</li> <li>• LX A5.0-10, LX A5.0-30: Accessory acquisition (optional)</li> <li>• GW14.3-BAT-LV-G10: Standard configuration</li> </ul>

No.	Cable	Recommended specifications	Acquisition method
8	Smart meter RS485 communication cable	<ul style="list-style-type: none"> <li>• Shielded twisted pair cable</li> <li>• Conductor Cross-sectional area: 0.2mm<sup>2</sup>-0.4mm<sup>2</sup></li> </ul>	Prepared by customers
9	Communication cable for parallel connected inverters WiFi/LAN Kit-20 communication cable	CAT 5E and above standard shielded network cable and RJ45 shielded connector	Prepared by customers
10	Remote shutdown communication cable Rapid shutdown communication cable NS Protection communication cable	<ul style="list-style-type: none"> <li>• Copper core twisted pair cable</li> <li>• Conductor Cross-sectional area: 0.2mm<sup>2</sup>-0.4mm<sup>2</sup></li> </ul>	Prepared by customers

## 6.4 Connecting the PE Cable

**WARNING**

- The PE cable connected to the enclosure of the inverter cannot replace the PE cable connected to the AC output port. Make sure that both of the two PE cables are securely connected.
- Make sure that all the grounding points on the enclosures are equipotential connected when there are multiple inverters.
- To improve the corrosion resistance of the terminal, it is recommended to apply silica gel or paint on the ground terminal after installing the PE cable.
- Connect the PE cable first before installing the equipment; Disconnect the PE cable before dismantling the equipment.

## Inverter

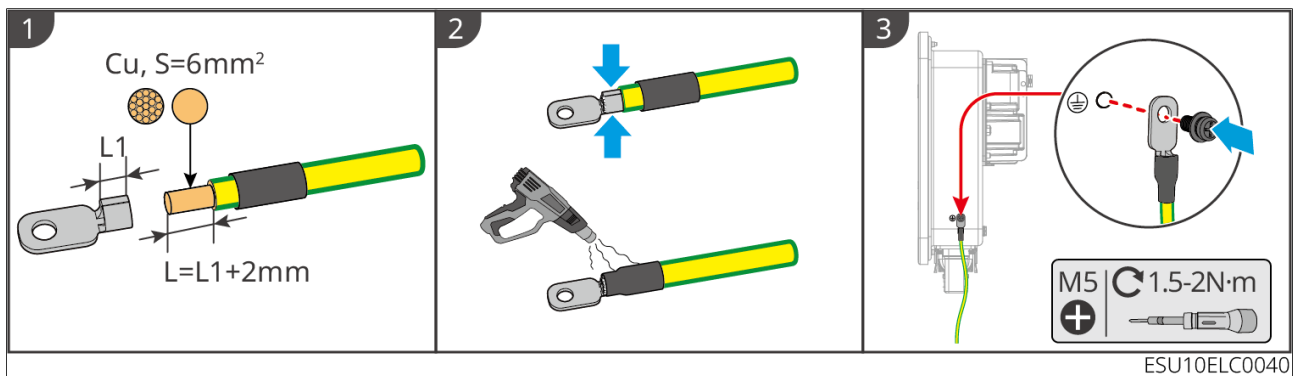

## Batteries

- GW14.3-BAT-LV-G10: If the grounding cables are shipped together with the battery accessories, please use the shipped cables; no crimping is required.



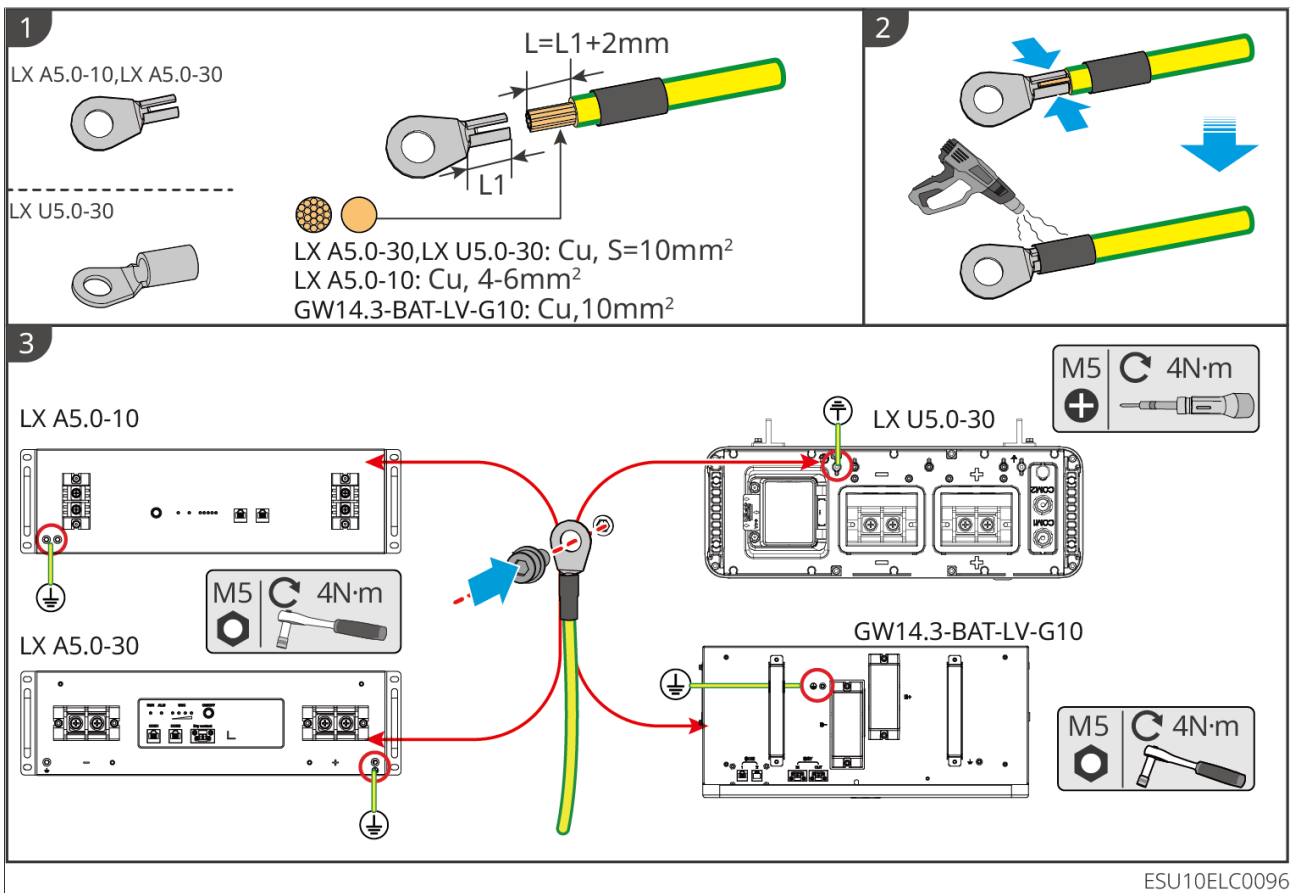

## 6.5 Connecting the PV Cable

### ⚠ DANGER

- Do not connect the same PV string to multiple inverters at the same time. Otherwise, the inverters may be damaged.
- Confirm the following information before connecting the PV string to the inverter. Otherwise, the inverter may be damaged permanently or even cause fire and cause personal and property losses.
  1. Make sure that the max short circuit current and the maximum input voltage per MPPT are within the permissible range.
  2. Make sure that the positive pole of the PV string connects to the PV+ of the inverter. And the negative pole of the PV string connects to the PV- of the inverter.

### ⚠ WARNING

- The PV strings cannot be grounded. Ensure the minimum insulation resistance of PV string to the ground meets the minimum insulation resistance requirements before connecting the PV string to the inverter ( $R = \text{maximum input voltage} / 30\text{mA}$ ).
- Ensure the DC cables are connected tightly, securely and correctly.
- Measure the positive and negative terminals of the DC cable using a multimeter to avoid reverse polarity connection. Also, the voltage should be within the permissible range.

### NOTICE

The two input strings per MPPT should contain the same number of identical PV modules with the same tilt and angle to ensure the best efficiency.

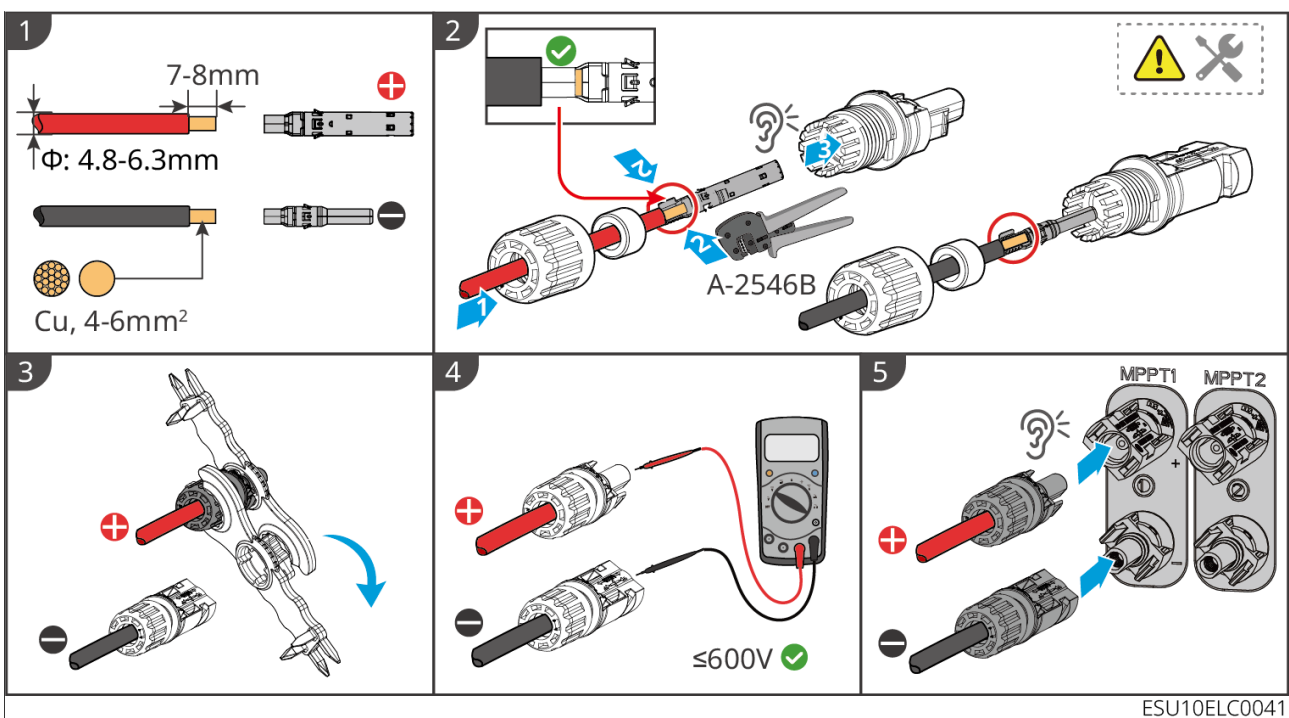

## 6.6 Connecting the Battery Cable

**! DANGER**

- In a single inverter system, do not connect the same battery pack to multiple inverters, which may cause inverter damage.
- It is forbidden to connect loads between the inverter and the battery.
- When connecting battery cables, use insulated tools to prevent accidental electric shock or short circuit to the batteries.
- Ensure that the open circuit voltage of the battery is within the permissible range of the inverter.
- Install a DC breaker between the inverter and the battery in compliance with local laws and regulations.

### Battery system wiring diagram

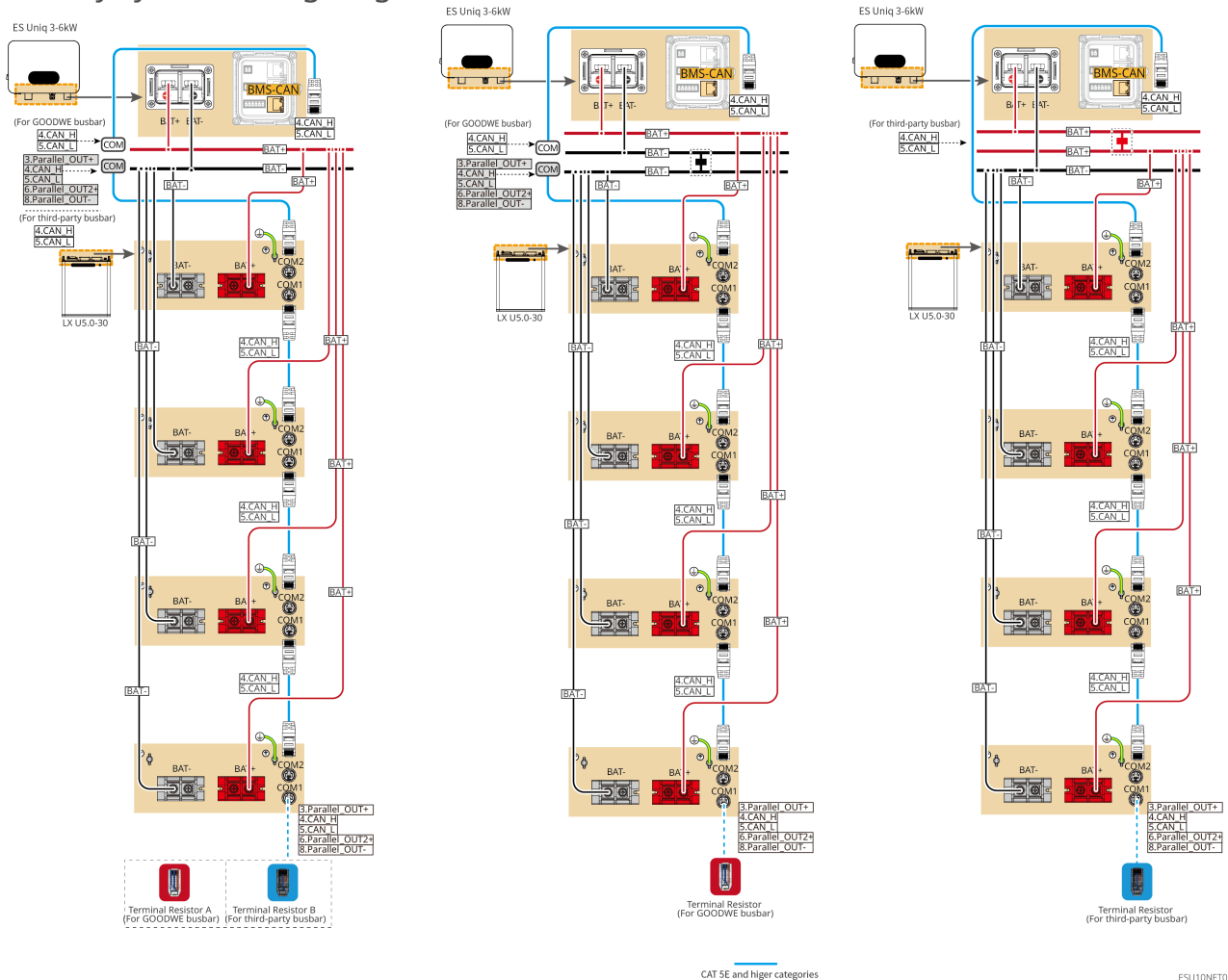

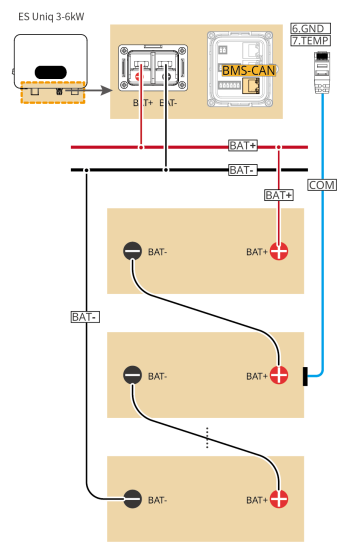
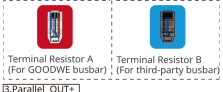
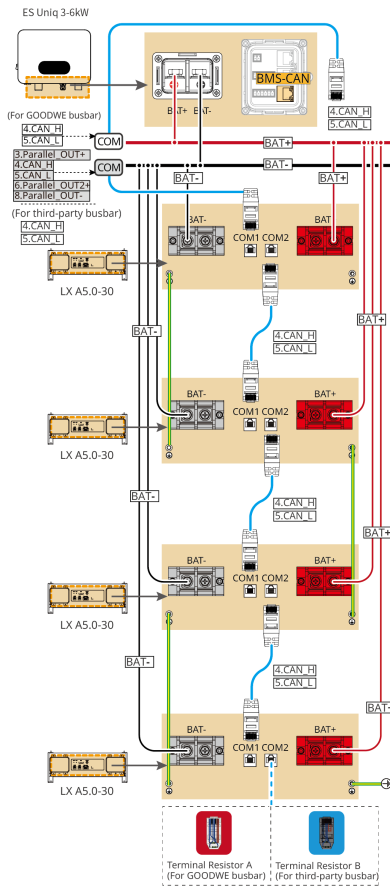
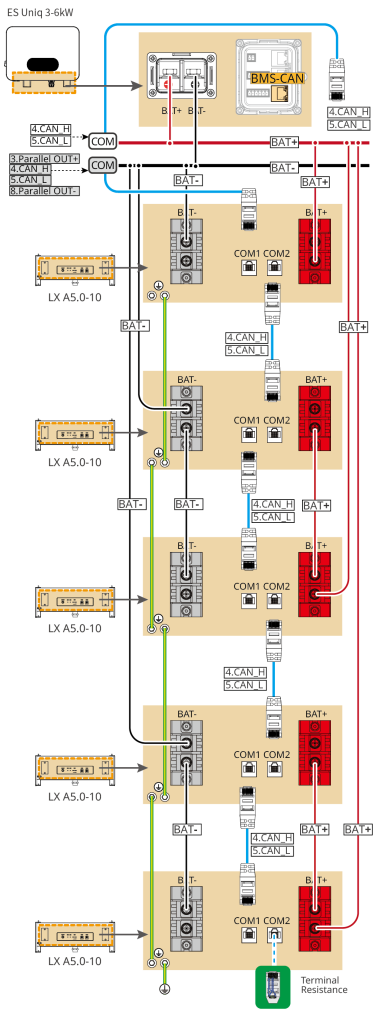

The quantity of batteries depends on the required voltage.

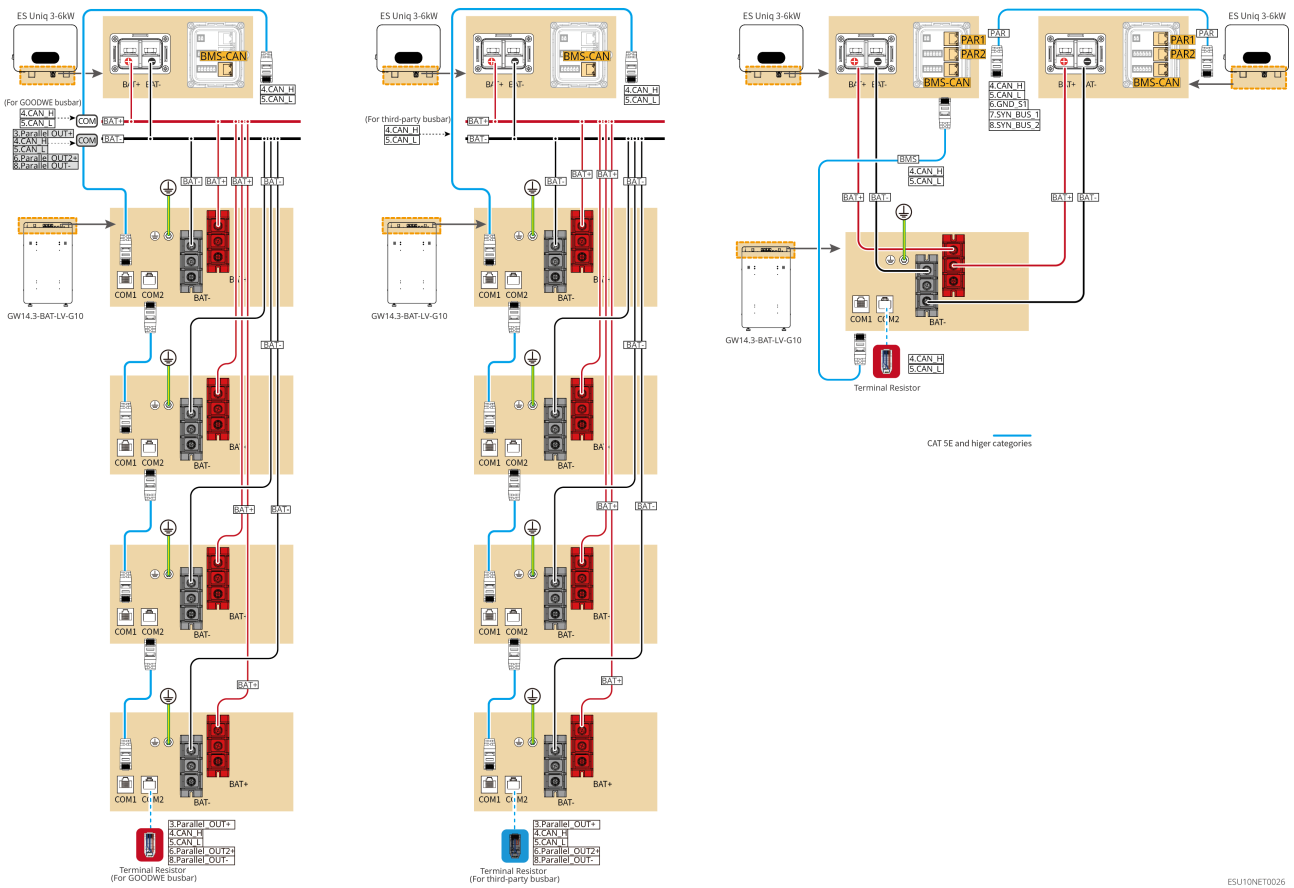

ESU10NET0026

### LXA5.0-30: Hand-to-hand connection

- The battery system supports a maximum working current of 160A, working power of 8kW, and it consists of a maximum of 1 inverter, and 30 batteries.

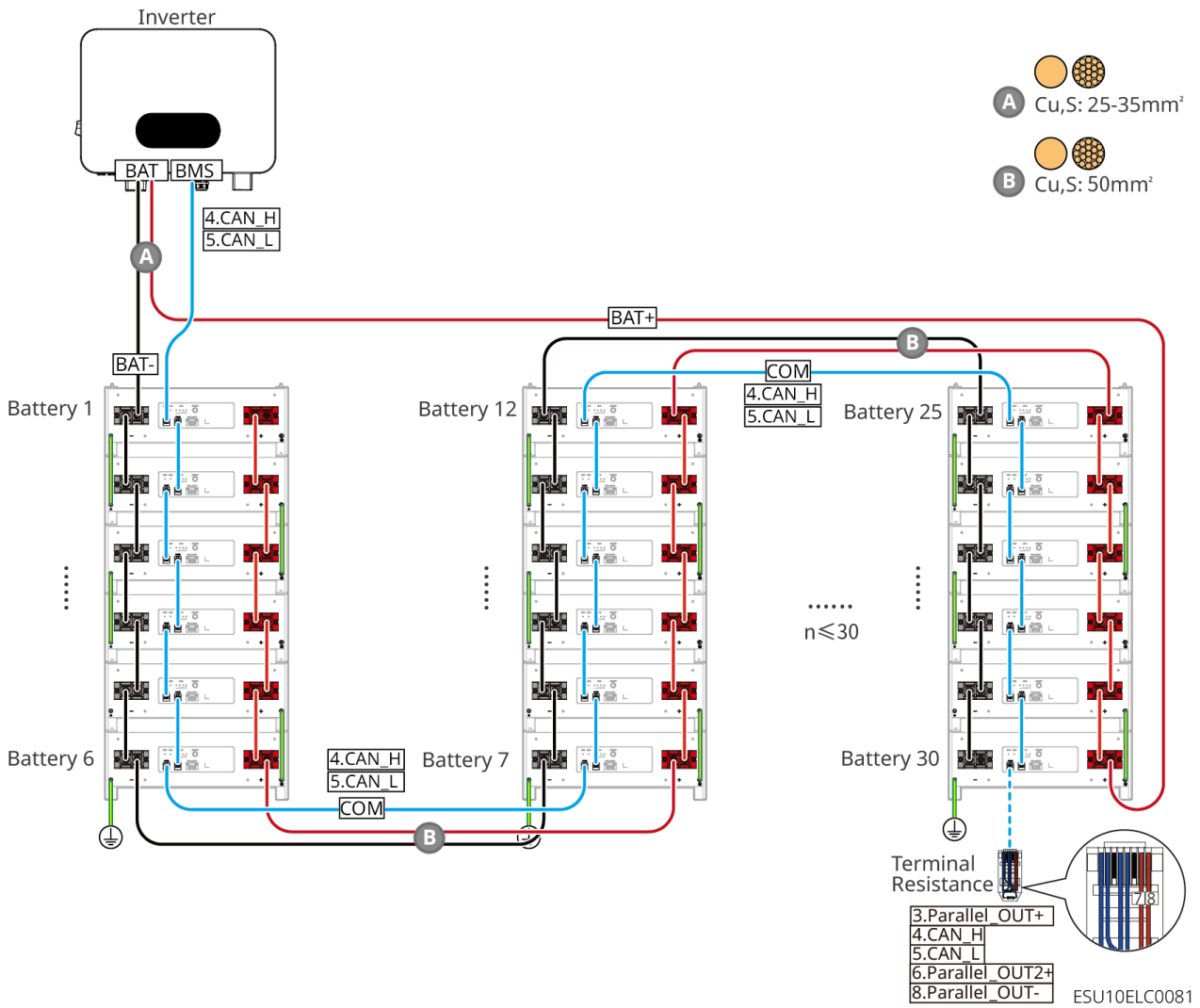

LXA5.0-30: Using with busbar BCB-22-WW-0

- The battery system supports a maximum working current of 160A, working power of 8kW, and it consists of a maximum of 6 inverter, and 6 batteries.

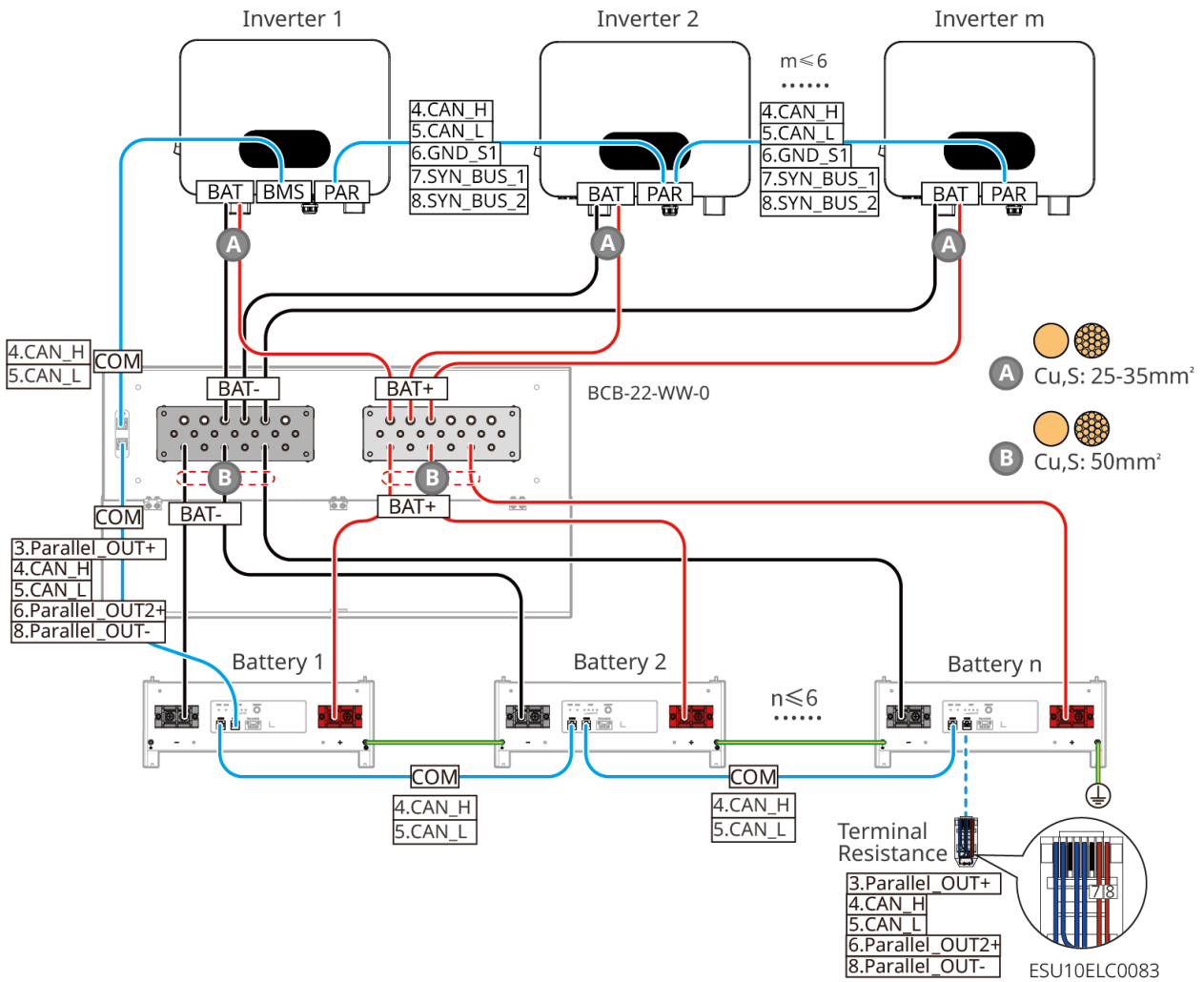

### LXA5.0-30: Using with busbar BCB-32-WW-0

- The battery system supports a maximum working current of 160A, working power of 8kW, and it consists of a maximum of 6 inverter, and 15 batteries.

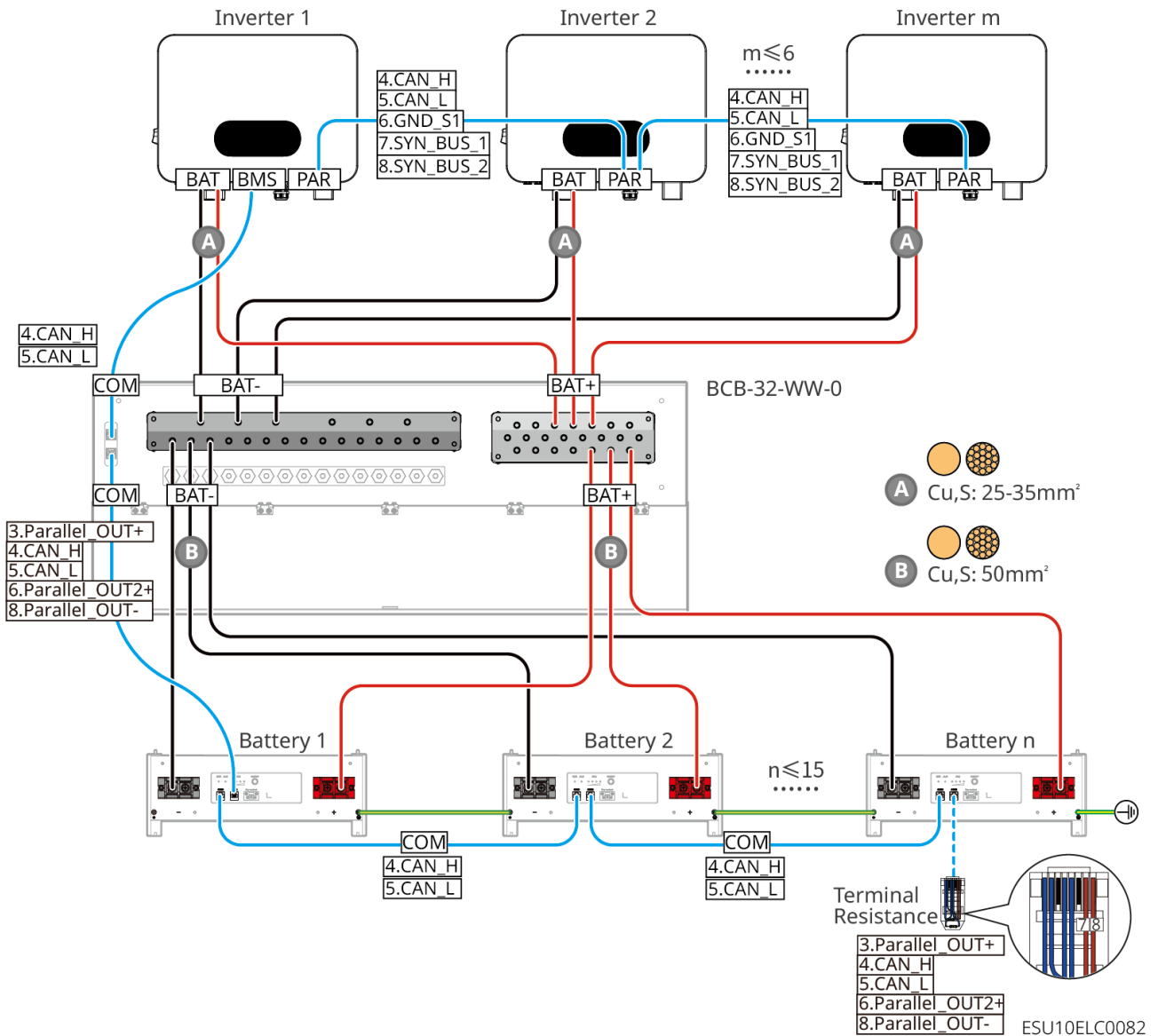

### LXA5.0-30: Using with third-party busbar

- The nominal charging current of a single battery is 60A; and the nominal discharging current is 100A; the maximum charging current is 90A; the maximum discharging current is 150A. A maximum of 30 batteries can be connected in parallel in one system.



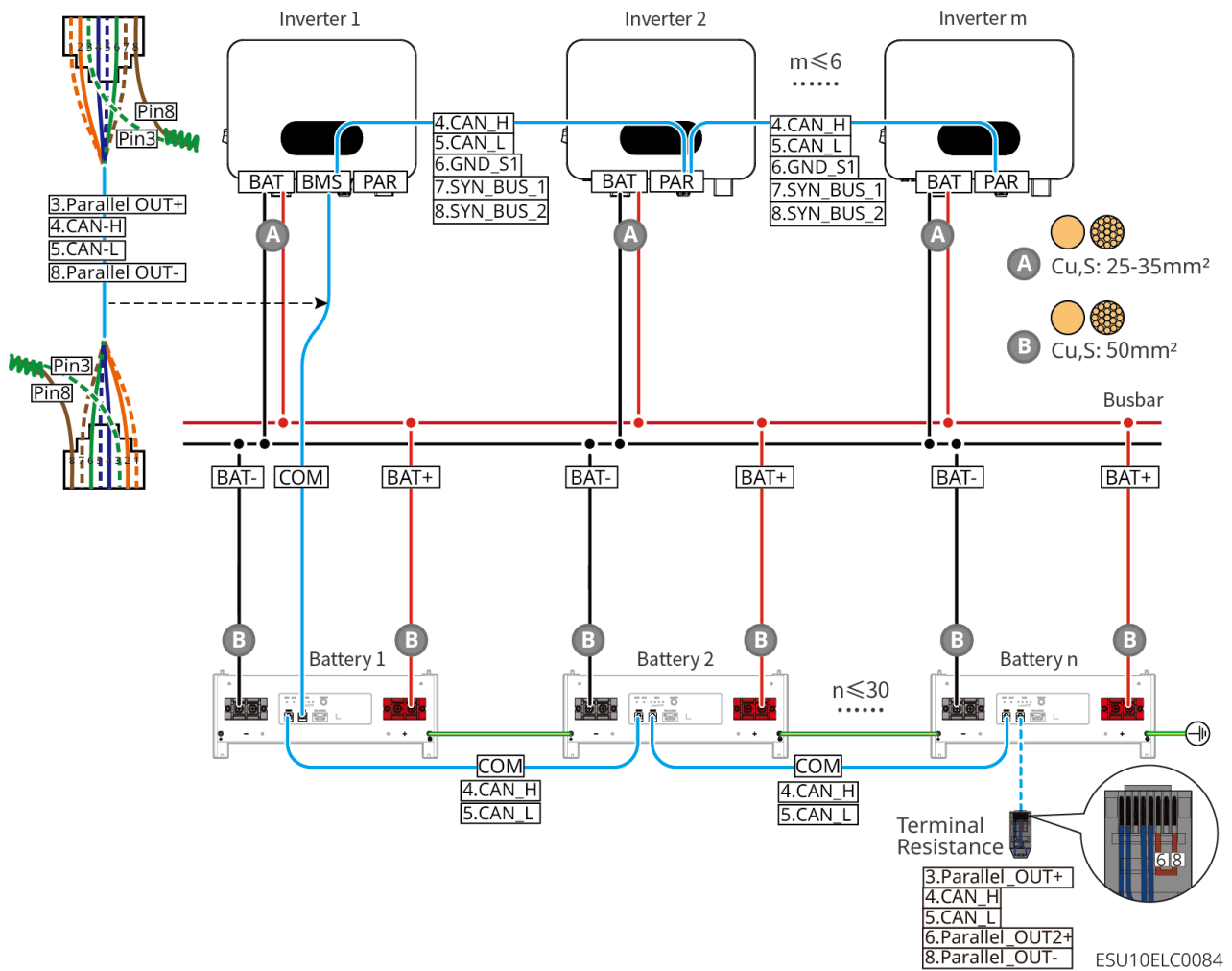

## LX A5.0-10: Hand-to-Hand Connection

- The nominal charging and discharging current of a single battery is 60A.
- The battery system supports a maximum working current of 160A, working power of 8kW, and it consists of a maximum of 1 inverter, and 2 batteries.

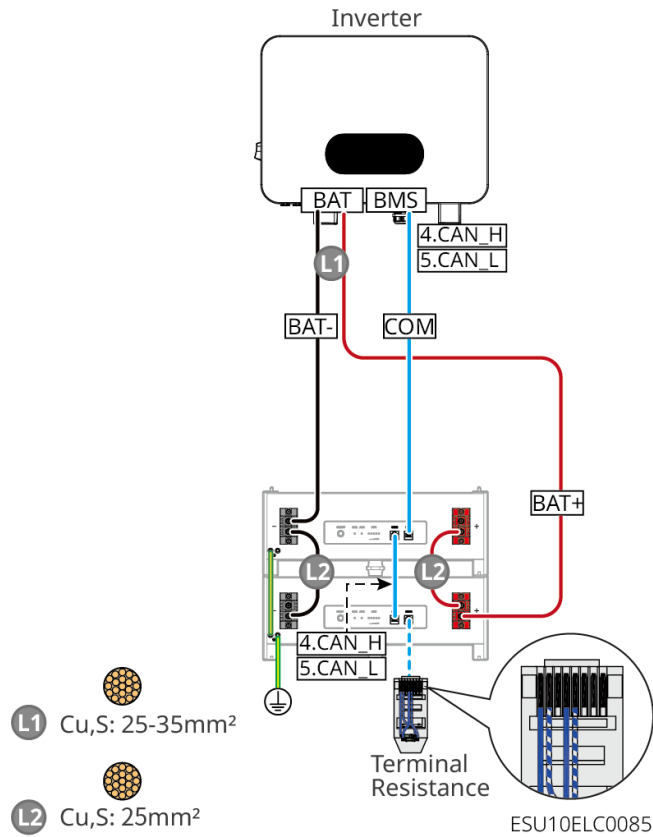

#### LX A5.0-10: Using with busbar BCB-22-WW-0

- The nominal charging and discharging current of a single battery is 60A.
- The battery system supports a maximum working current of 360A, working power of 18kW, and it consists of a maximum of 3 inverters, and 6 batteries.

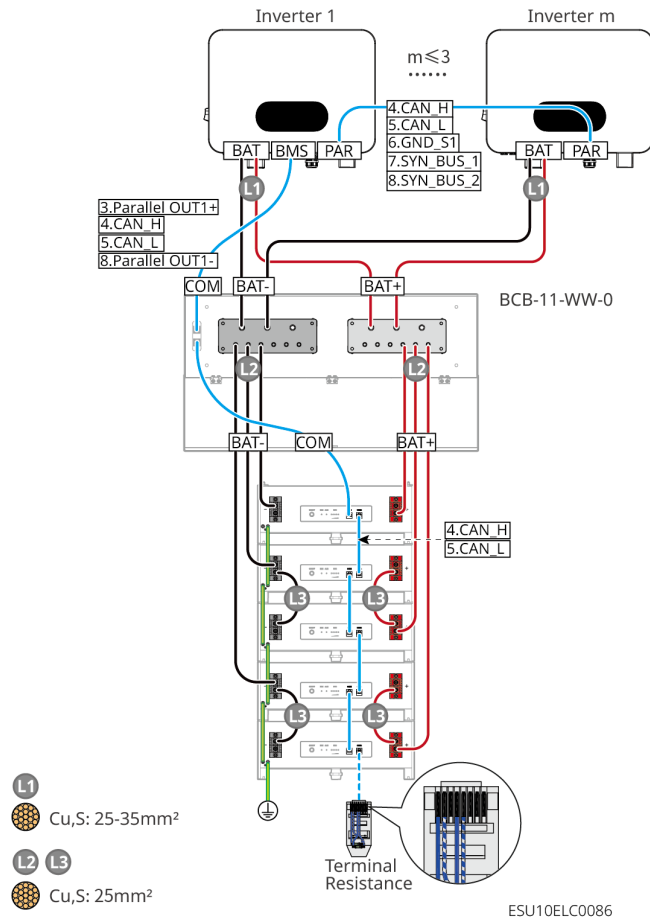

### LX A5.0-10: Using with busbar BCB-22-WW-0

- The nominal charging and discharging current of a single battery is 60A.
- The battery system supports a maximum working current of 160A, working power of 8kW, and it consists of a maximum of 6 inverter, and 12 batteries.

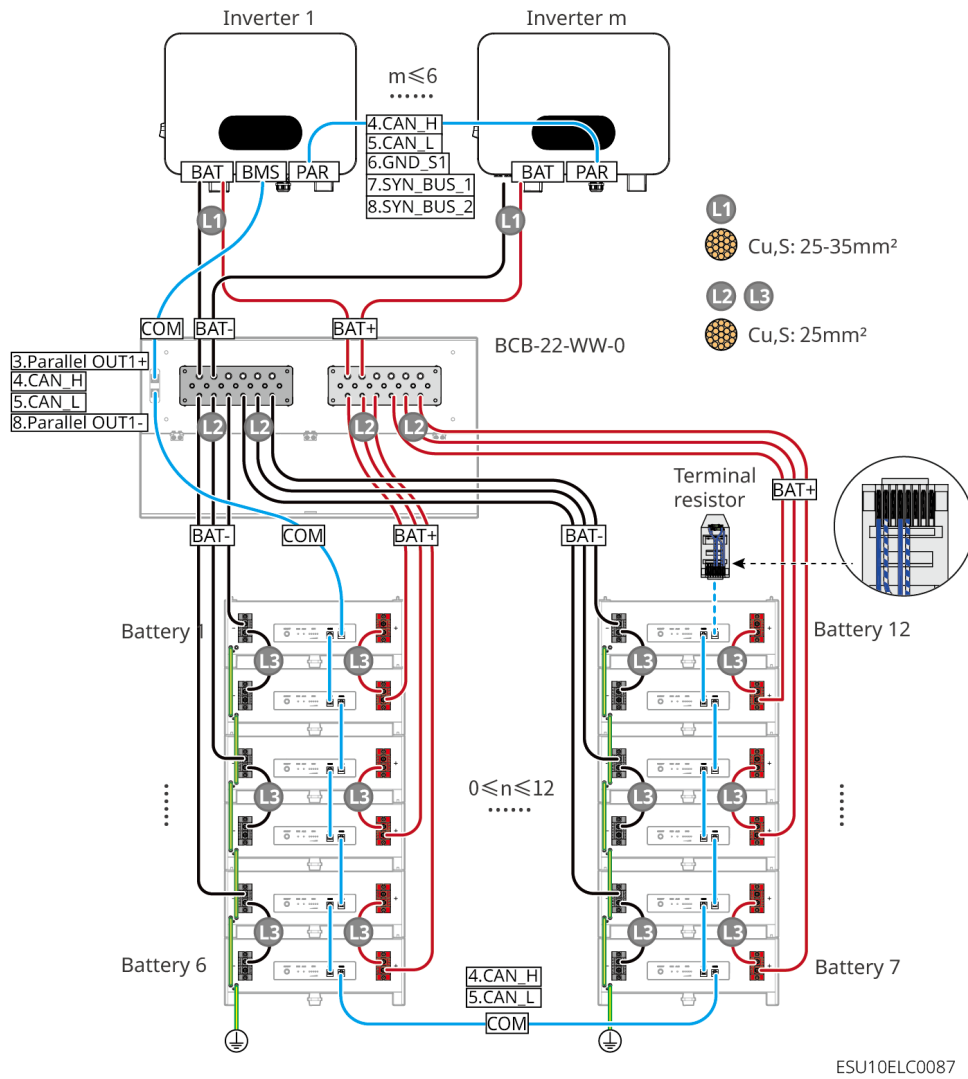

ESU10ELC0087

### LX A5.0-10: Using with third-party busbar

- The nominal charging and discharging current of a single battery is 60A.
- The battery system supports a maximum working current of 900A, working power of 45kW, and 15 batteries.

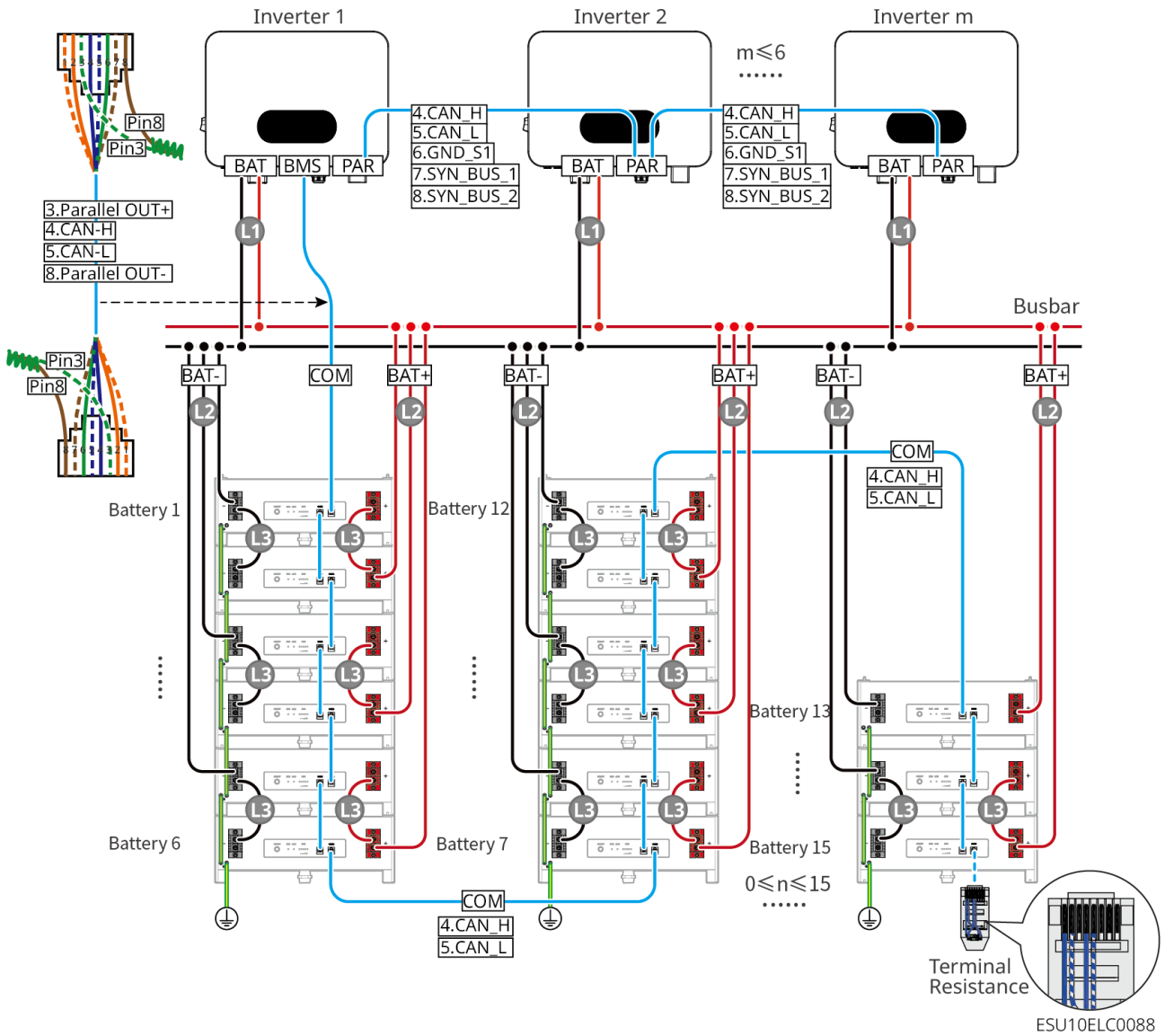

LX U5.0-30: Hand-to-Hand Connection

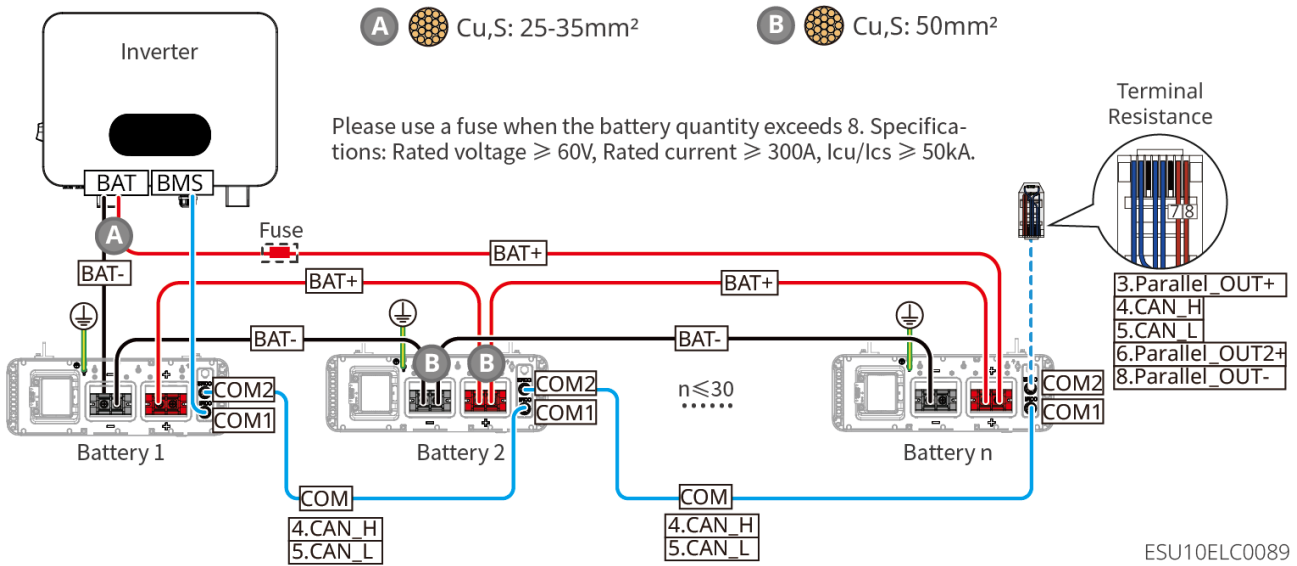

LX U5.0-30: When the battery quantity is less than or equal to 6, and the busbar BCB-22-WW-0 is used, the wiring diagram is as follows:

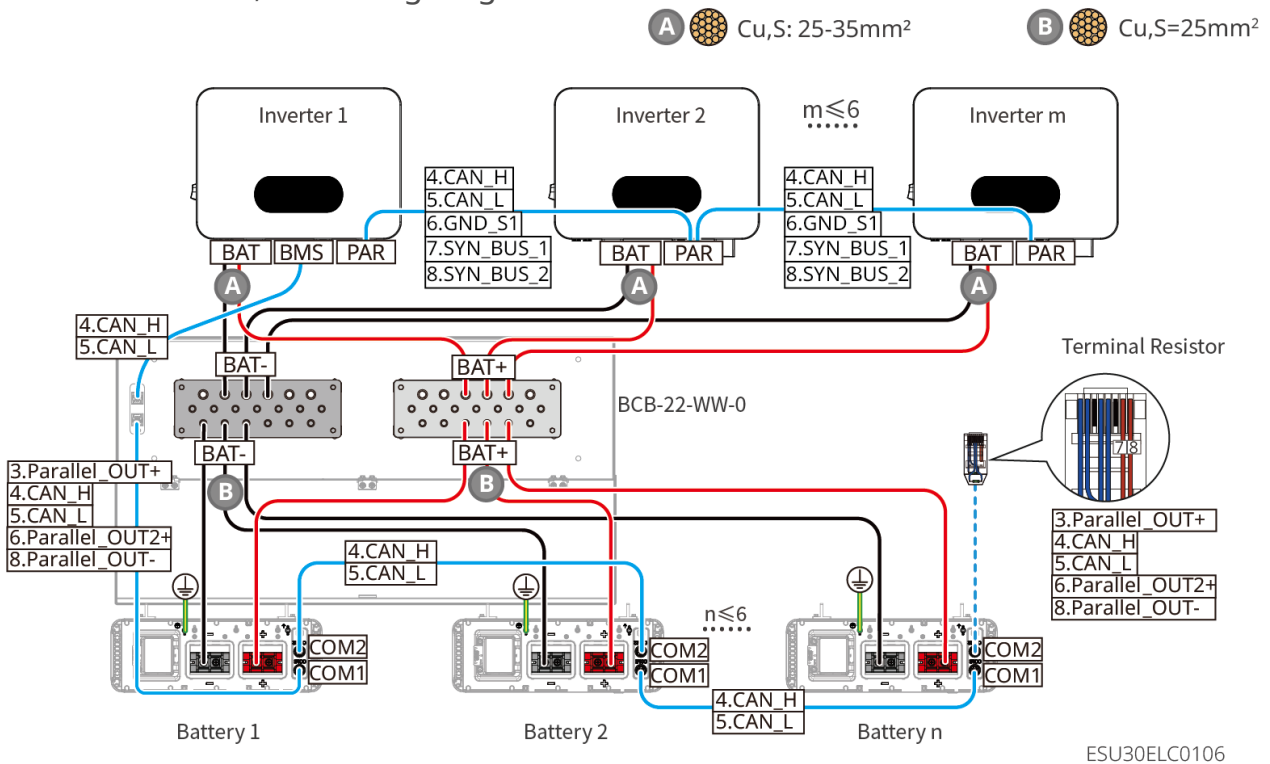

LX U5.0-30: When the battery quantity is less than or equal to 8, and the busbar BCB-32-WW-0 is used, the wiring diagram is as follows:

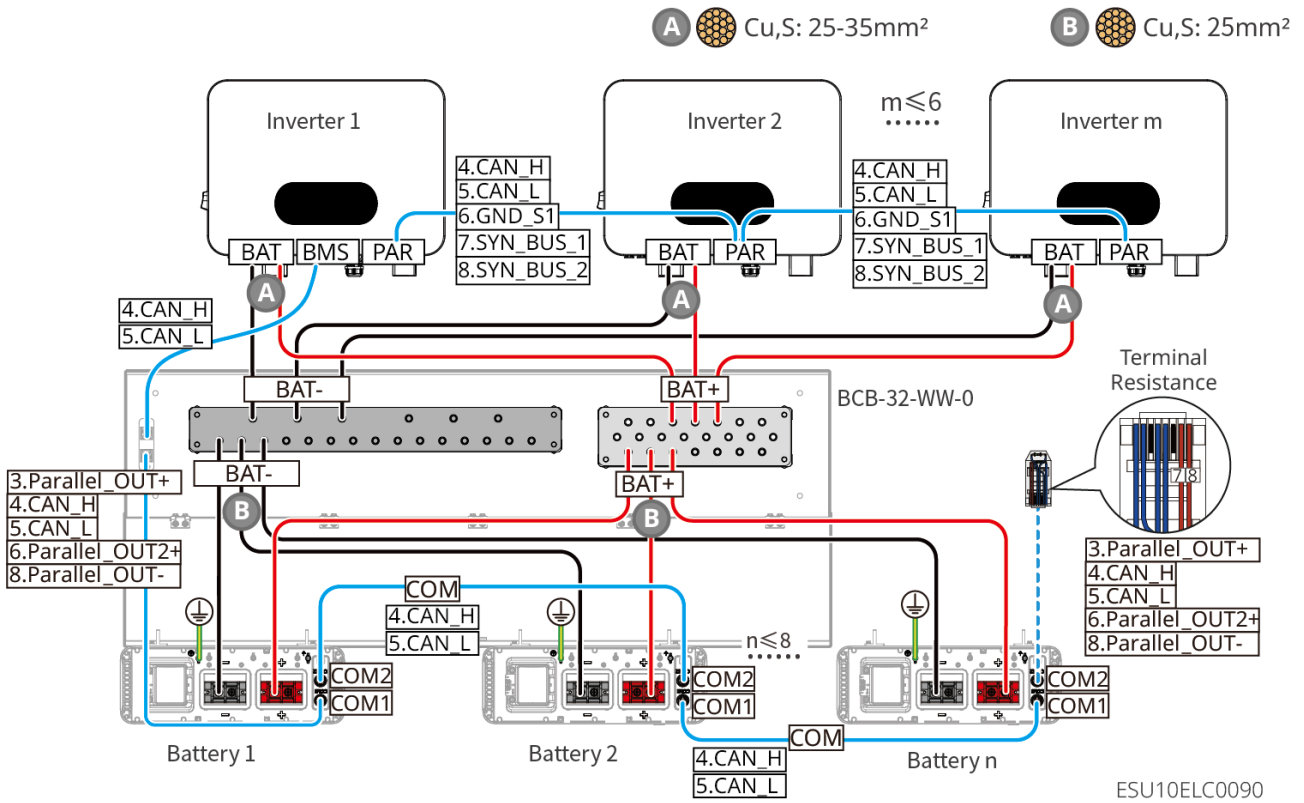

LX U5.0-30: When the battery quantity is less than or equal to 15, and the busbar BCB-33-WW-0 is used, the wiring diagram is as follows:

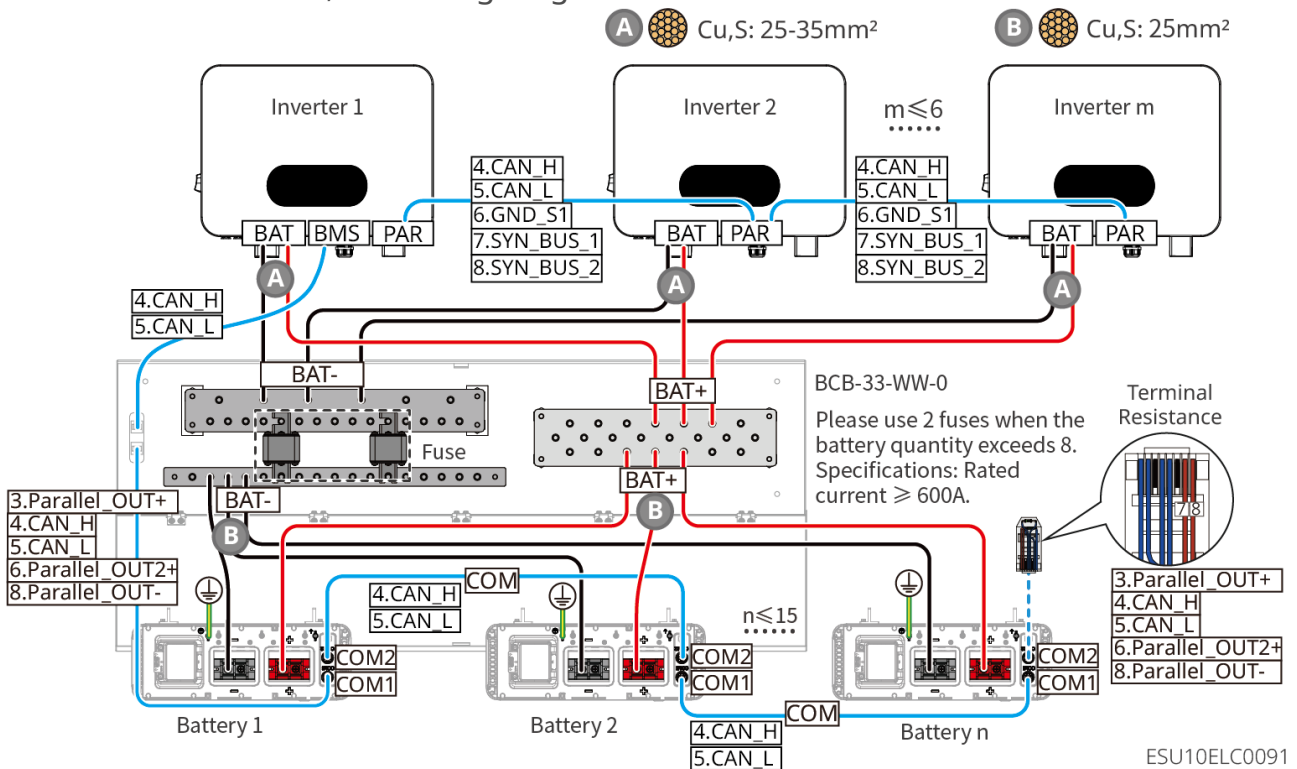

LX U5.0-30: When the battery quantity is less than or equal to 8, and a third-party busbar is used, the wiring diagram is as follows:

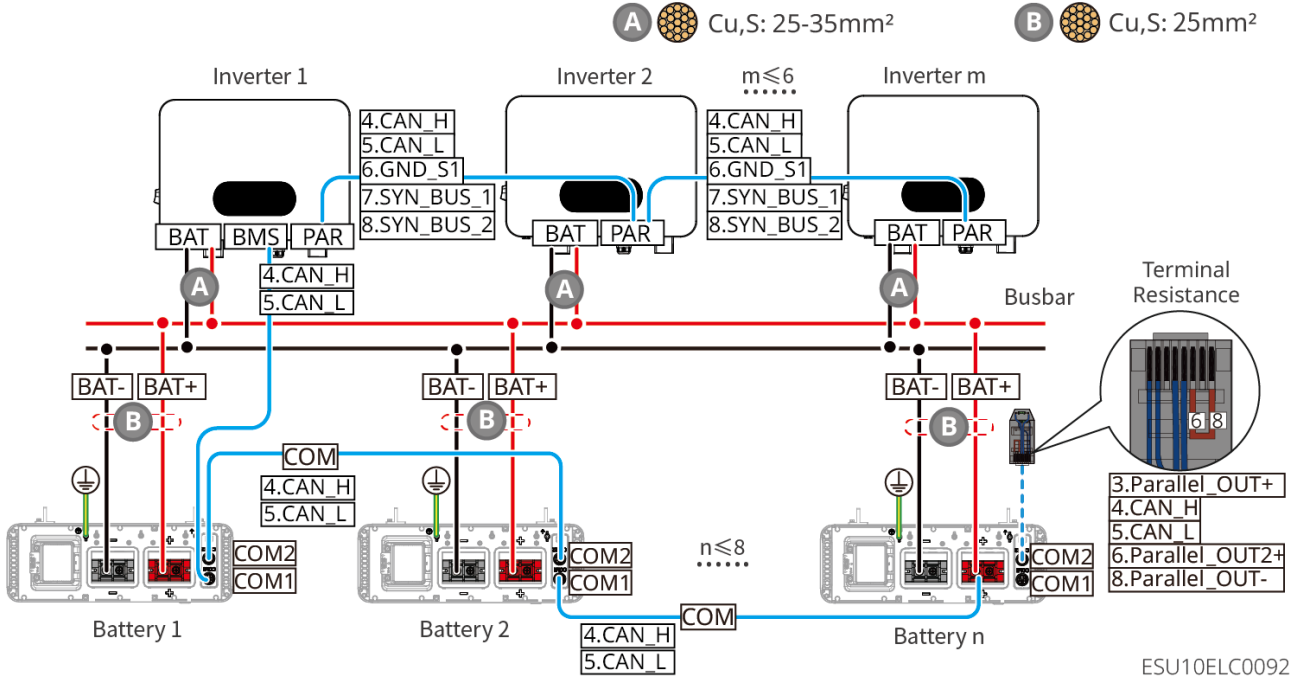

LX U5.0-30: When the battery quantity is larger than 8, and a third-party busbar is used, the wiring diagram is as follows:

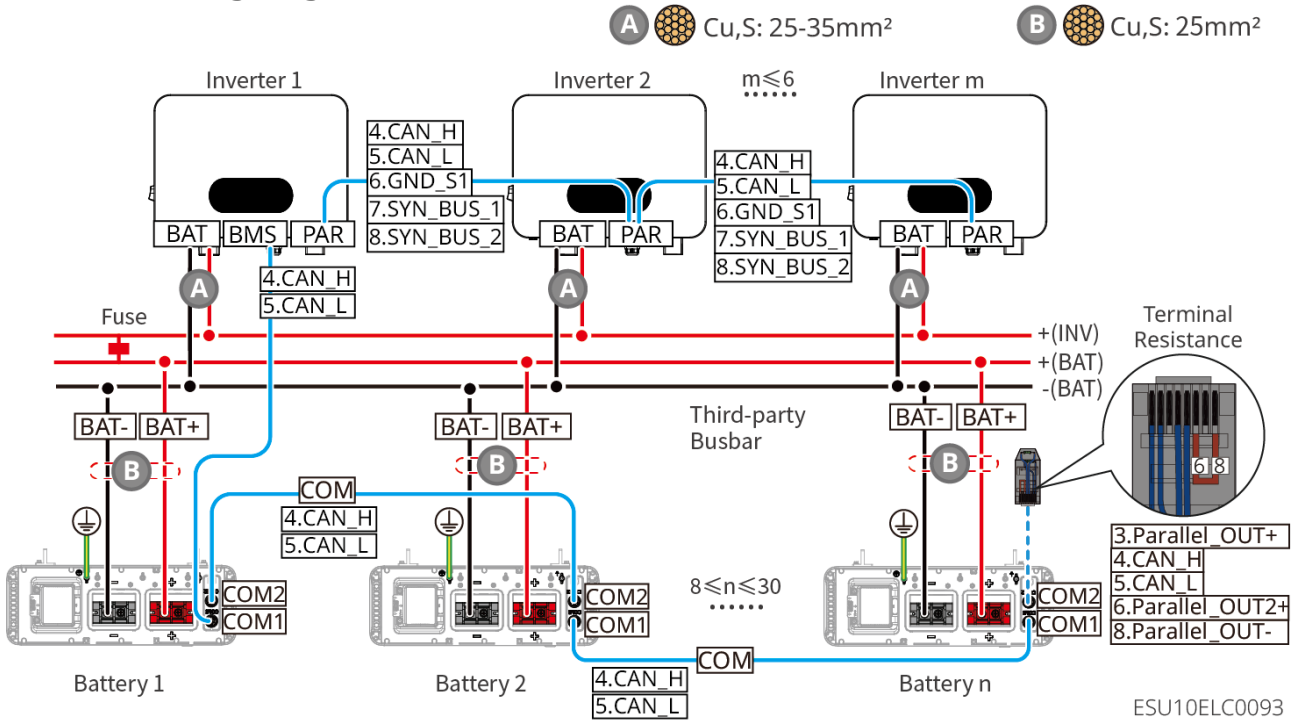

GW14.3-BAT-LV-G10: When the battery is directly connected to a single 1-way output



inverter, the wiring diagram is as follows:

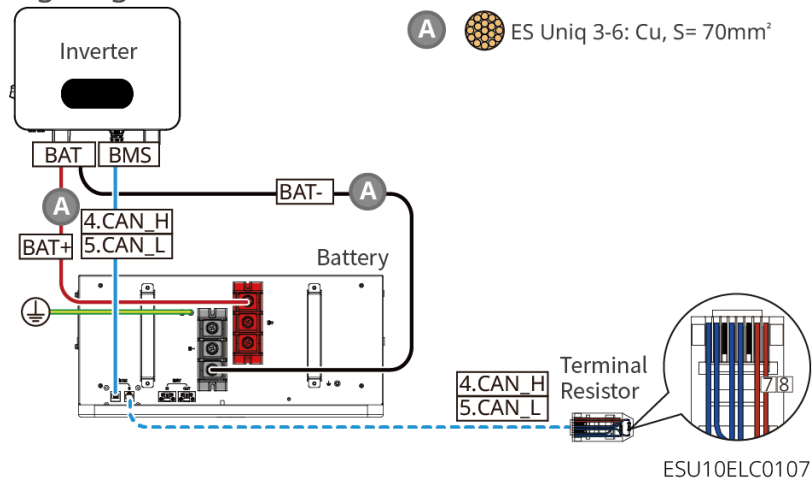

GW14.3-BAT-LV-G10: When the battery is directly connected to two 1-way output inverters, the wiring diagram is as follows:

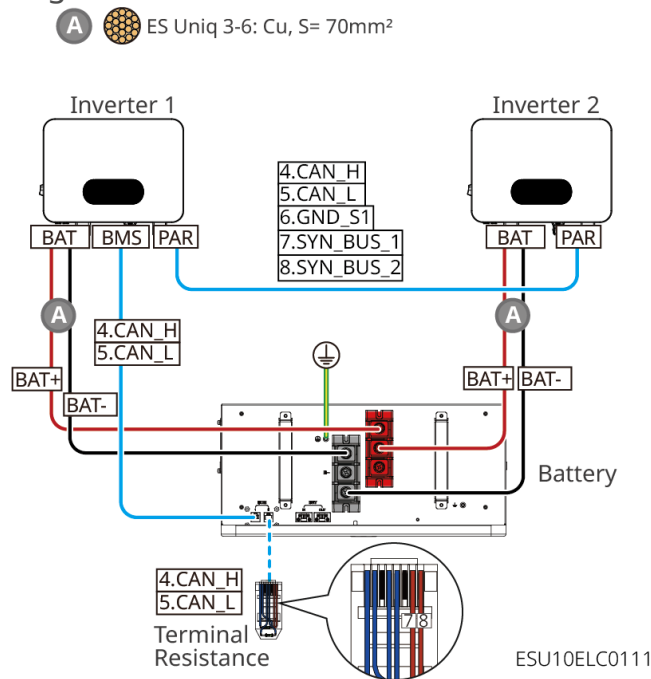

GW14.3-BAT-LV-G10: When the battery is in hand-to-hand connection with a single 1-way output inverter, the wiring diagram is as follows:

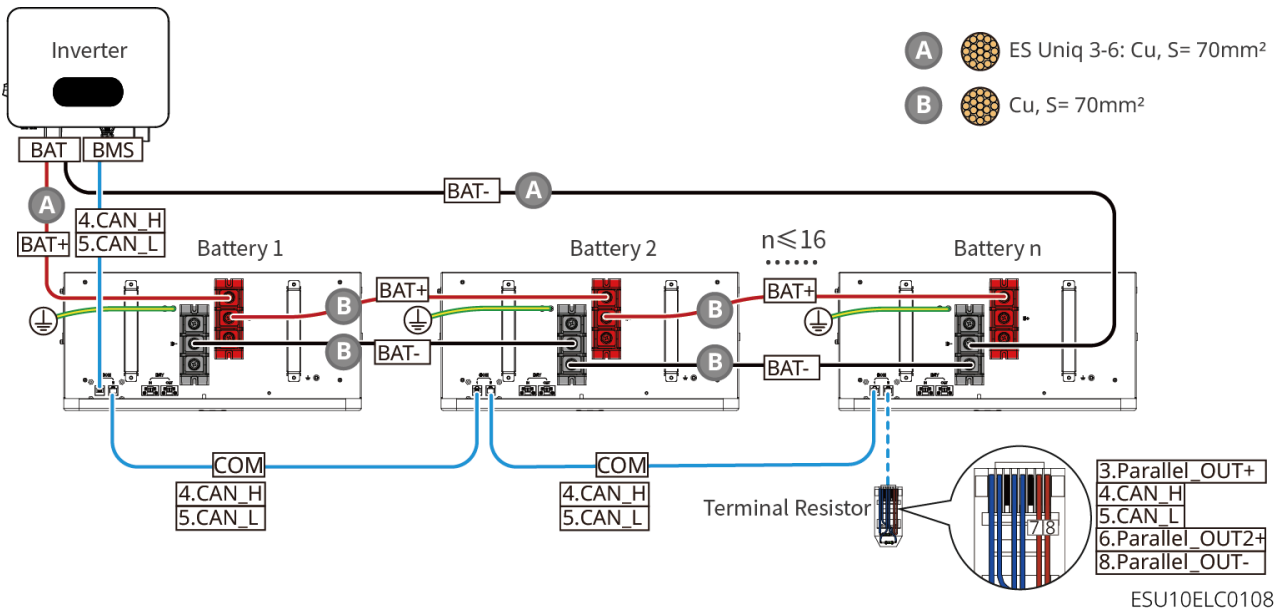

GW14.3-BAT-LV-G10: When the number of batteries is less than or equal to 15 and a busbar (BCB-32-WW-0, current  $\leq 720A$ ) is used to connect one output inverter, the wiring diagram is as follows:

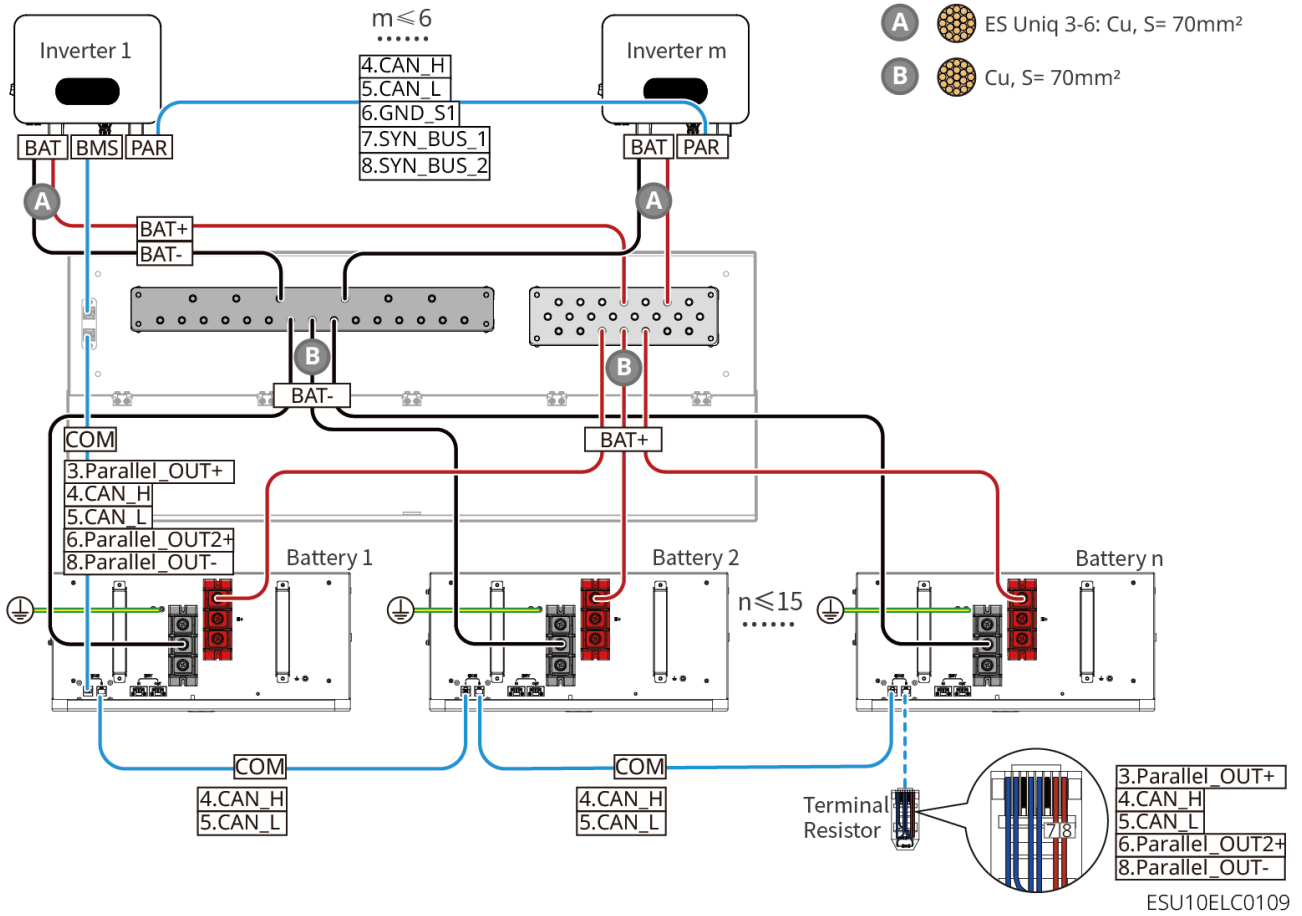

GW14.3-BAT-LV-G10: When the number of batteries is less than or equal to 16 and a third-party busbar is used to connect to a single-output inverter, the wiring diagram is as follows:

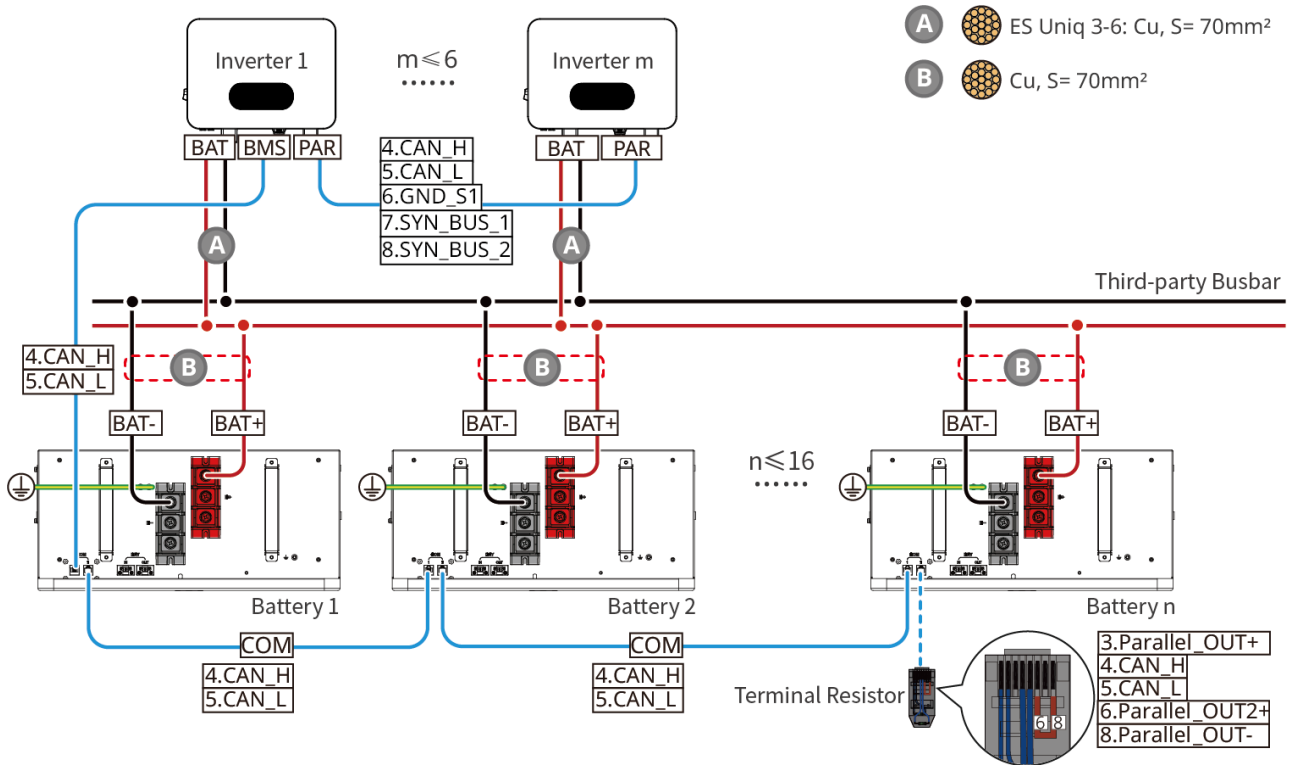

ESU10ELC0110

### LX A5.0-30 Communication Port Definition

PIN	COM1	COM2	Description
1	-	-	Reserved
2	-	-	
3	Parallel OUT+	Parallel OUT+	Parallel operation communication port
4	CAN_1H	CAN_1H	Connect the inverter communication port or battery parallel communication port
5	CAN_1L	CAN_1L	
6	Parallel OUT2+	Parallel OUT2+	Parallel interlock communication port
7	-	-	Reserved
8	Parallel OUT-	Parallel OUT-	Parallel operation communication port

### LX A5.0-10 Communication Port Definition

PIN	COM1	COM2	Description
1	-	-	Reserved
2	-	-	
3	Parallel OUT+	Parallel OUT+	Parallel operation communication port
4	CAN_1H	CAN_1H	Connect the inverter communication port or battery parallel communication port
5	CAN_1L	CAN_1L	
6	-	-	Reserved
7	-	-	
8	Parallel OUT-	Parallel OUT-	Parallel operation communication port

#### LX U5.0-30 Communication Port Definition

PIN	COM1	COM2	Description
1	RS485A	RS485A	Reserved
2	RS485B-	RS485B-	
3	Parallel OUT+	Parallel OUT+	Parallel operation communication port
4	CAN_H	CAN_H	Connect the inverter communication port or battery parallel communication port
5	CAN_L	CAN_L	
6	Parallel OUT2+	Parallel OUT2+	Parallel operation communication port
7	-	-	Reserved
8	Parallel OUT-	Parallel OUT-	Parallel operation communication port

#### GW14.3-BAT-LV-G10 Communication Port Definition

PIN	COM1	COM2	Description
1	RS485A	RS485A	Reserved
2	RS485B-	RS485B-	
3	Parallel OUT+	Parallel OUT+	Parallel operation communication port
4	CAN_H	CAN_H	Connect the inverter communication port or battery parallel communication port
5	CAN_L	CAN_L	
6	Parallel OUT2+	Parallel OUT2+	Parallel operation communication port
7	-	-	Reserved
8	Parallel OUT-	Parallel OUT-	Parallel operation communication port

## 6.6.1 Connecting the Power Cable between the Inverter and Battery

### WARNING

- Measure the DC cables using a multimeter to avoid reverse polarity connection. Also, the voltage should be under the permissible range.
- Connect the battery cables to the corresponding terminals such as BAT, BAT+, BAT-, and grounding ports correctly. Otherwise, it will cause damage to the inverter.
- Ensure that the whole cable cores are inserted into the terminal holes, and no part of the cable core can be exposed.
- Ensure that the cables are connected securely. Otherwise, it will cause damage to the inverter due to overheating during its operation.
- Do not connect one battery pack to more than one inverter at the same time. Otherwise, it may cause damage to the inverter.

Overview of inverter and battery power cable



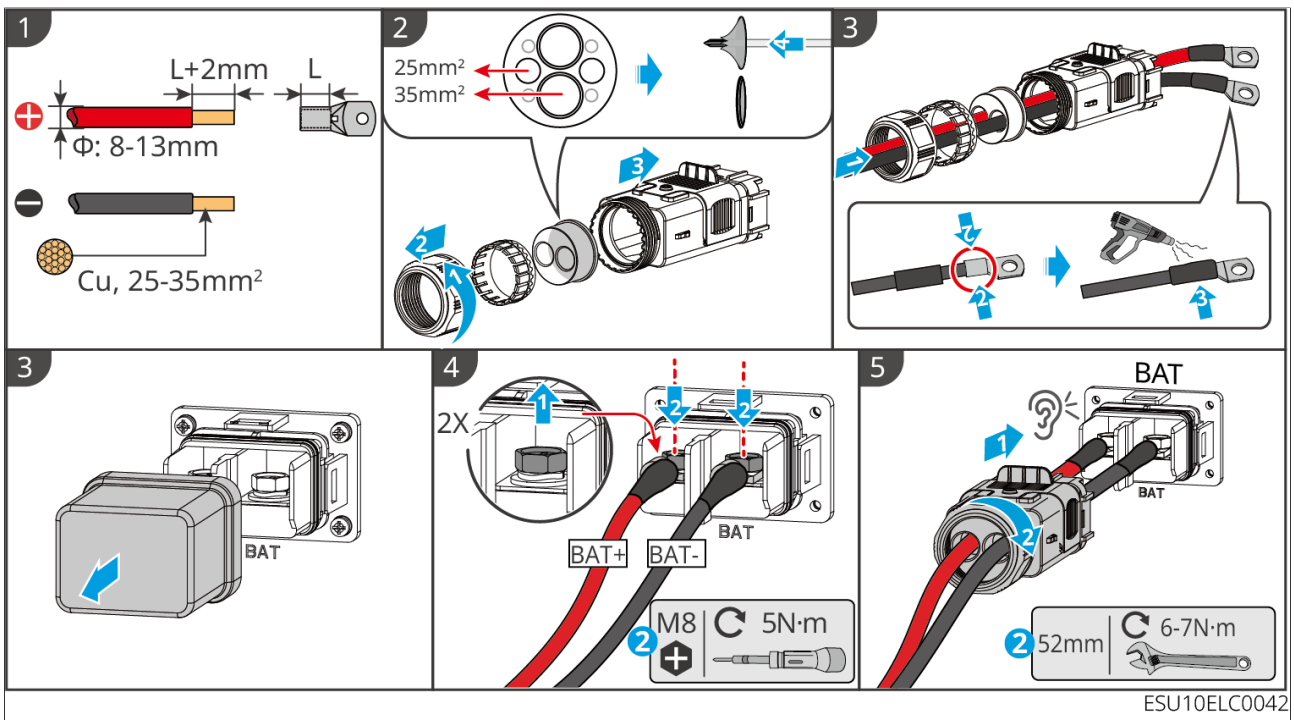

Inverter battery cover disassembly (optional)

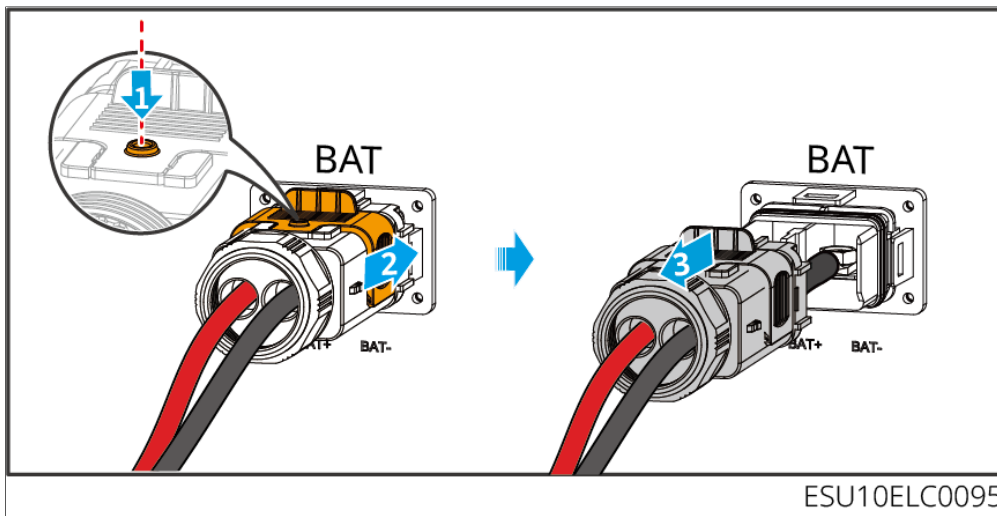

Battery power cable manufacturing (LX A5.0-10 and LX A5.0-30)

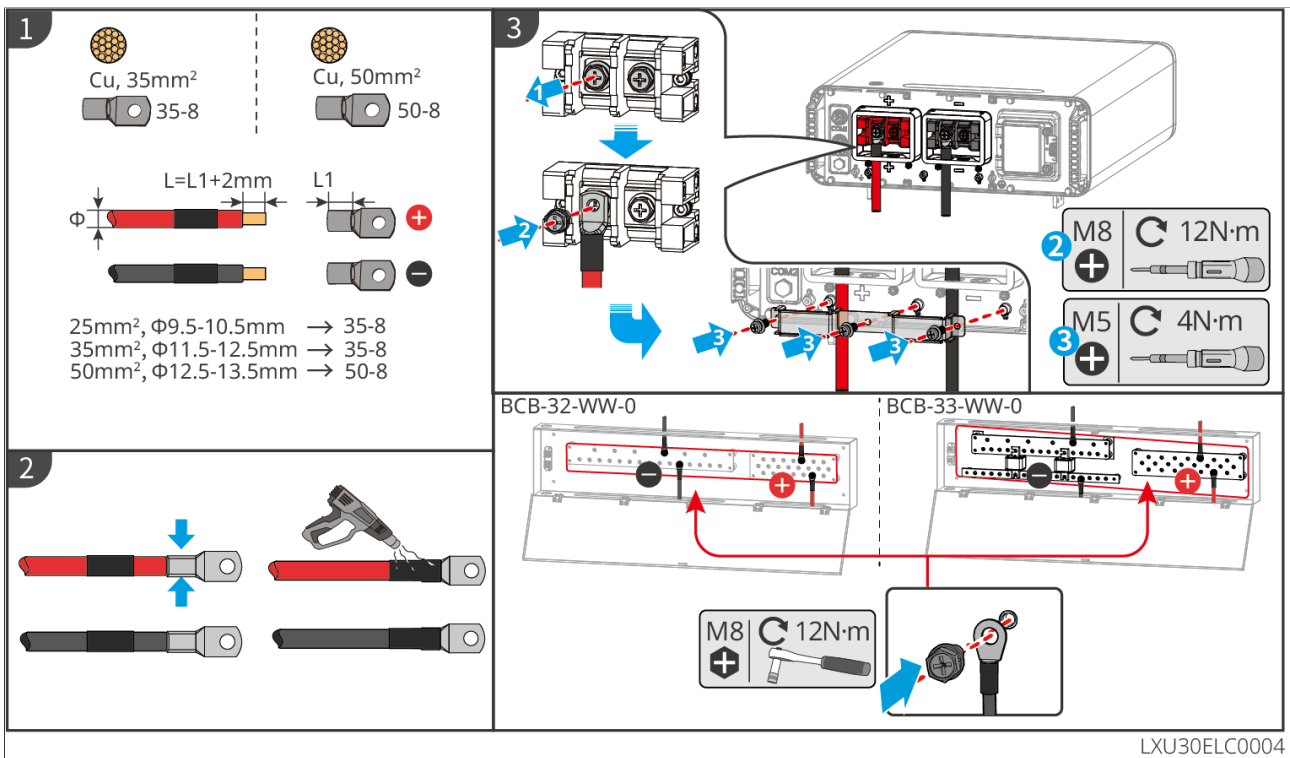

Battery power cable manufacturing (LXU 5.0-)

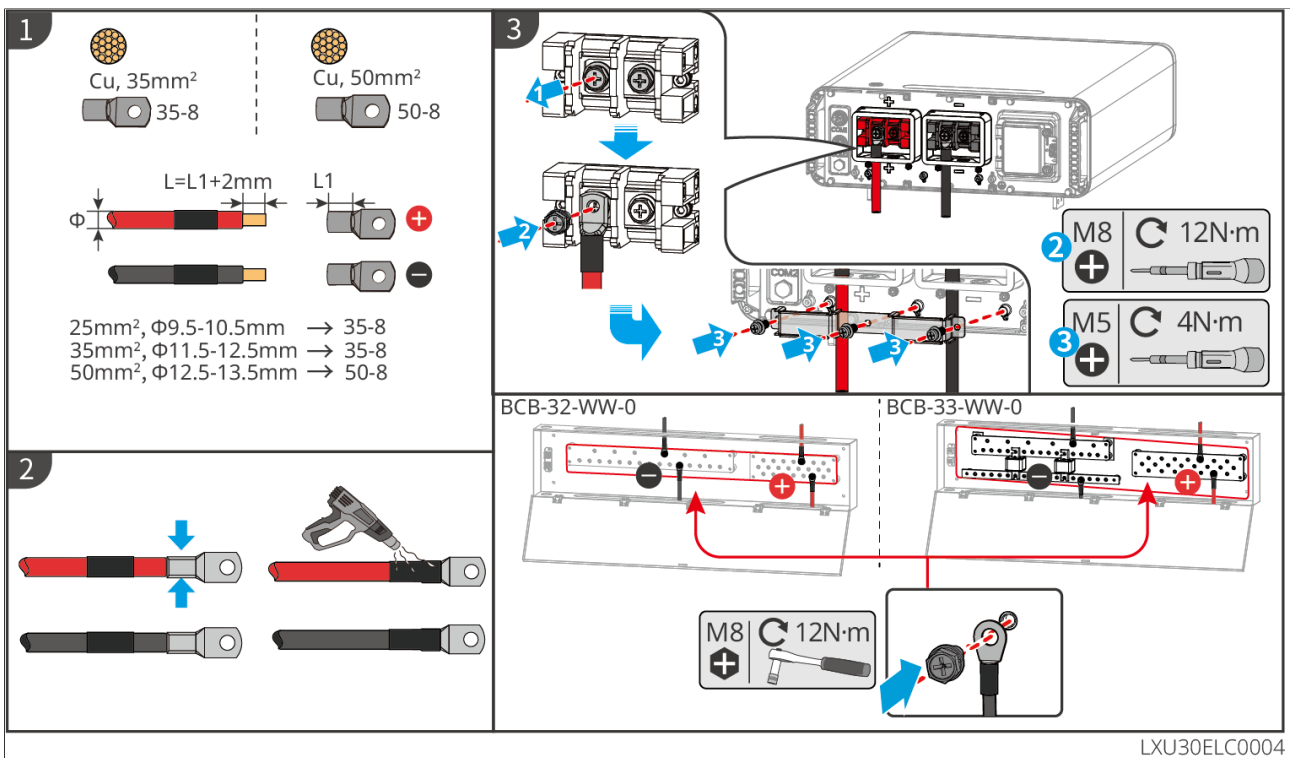

Battery power cable manufacturing (GW14.3-BAT-LV-G10)



- GW14.3-BAT-LV-G10: If the grounding cables are shipped together with the battery accessories, please use the shipped cables; no crimping is required.

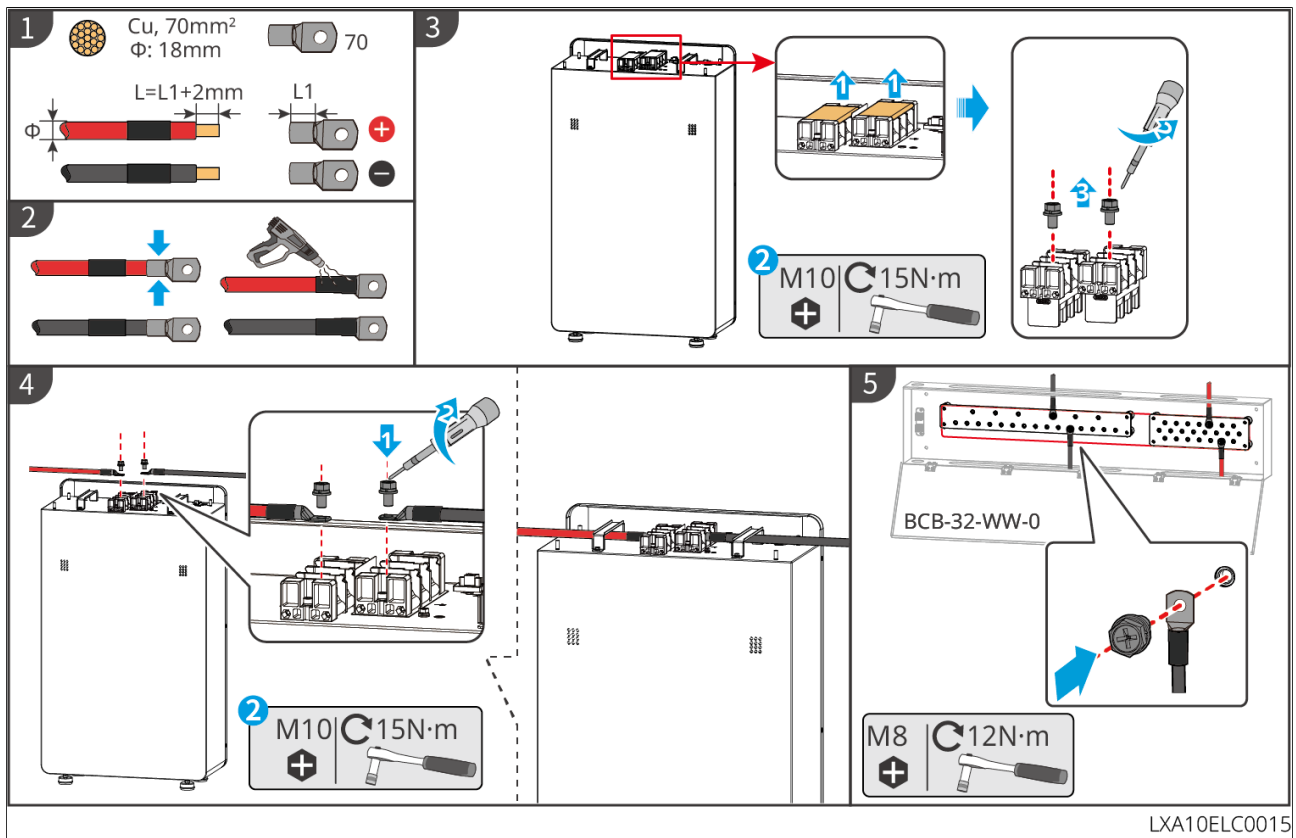

## 6.6.2 Connecting the Communication Cable between the Inverter and Battery

### NOTICE

It is recommended to use the included BMS communication cable in the package of the inverter. If the included communication cables do not meet the requirement, prepare shielded network cables and RJ connectors by yourself to make the cable. Only crimp PIN4 and PIN5 of the connector when making the cable, otherwise the communication may fail.

Instructions for BMS communication connection between inverter and battery

Inverter port	Connected to the battery port	Port definition	Description
BMS(CAN)	COM1	4: CAN_H 5: CAN_L	<ul style="list-style-type: none"> <li>The inverter communicates with the battery through CAN.</li> <li>Connect the BMS port of the inverter to the COM1 port of the battery.</li> </ul>

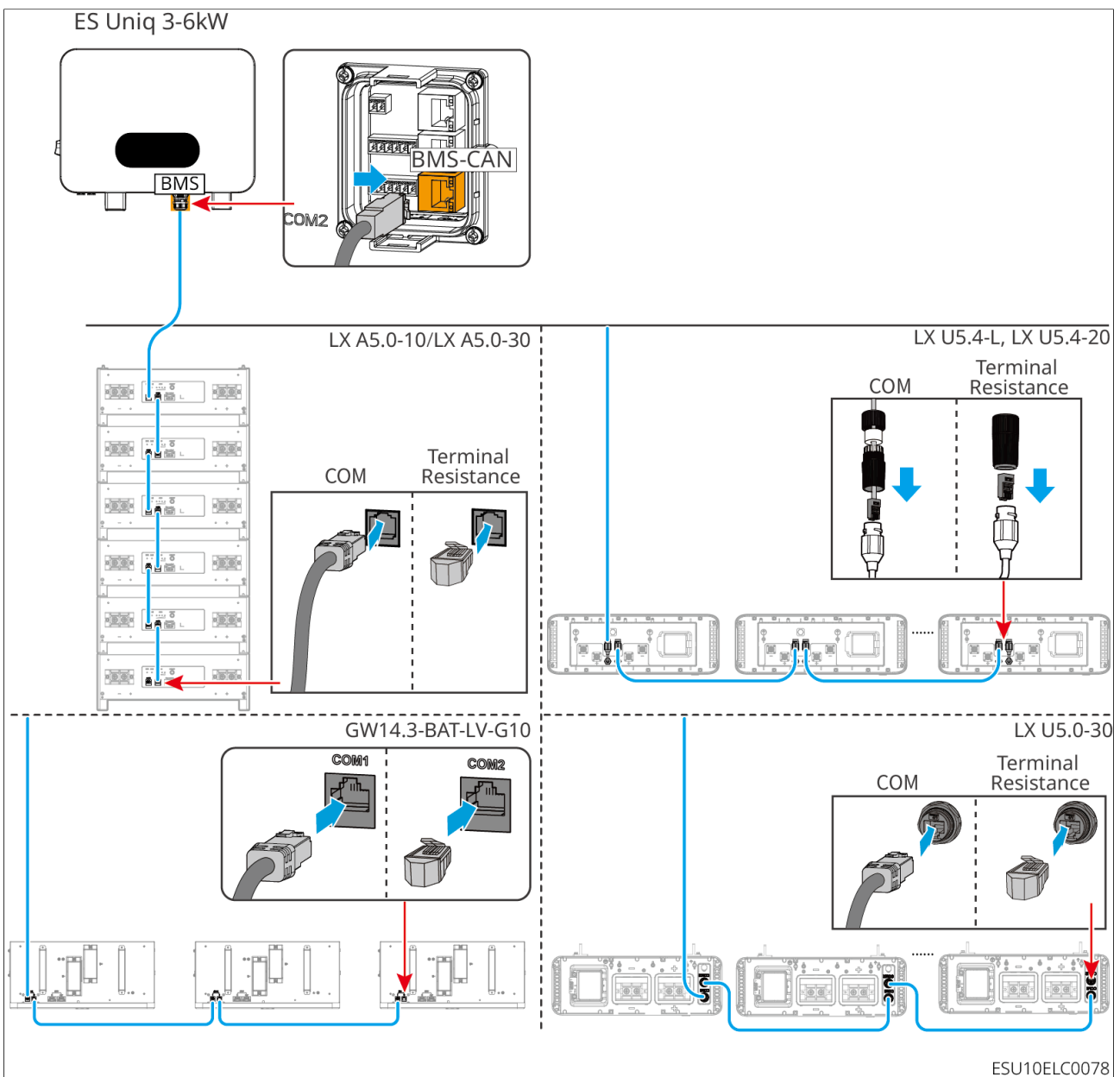

## NOTICE

- When connecting the lead-acid battery temperature sensor cable, it is recommended to connect the temperature sensor cable at a location with poor heat dissipation. For example, when lead-acid batteries are placed side by side, the sensor should be fixed on the lead-acid battery located in the middle.
- To better protect the battery cell, a temperature sampling cable must be installed, and it is recommended to place the battery in a well-ventilated environment.

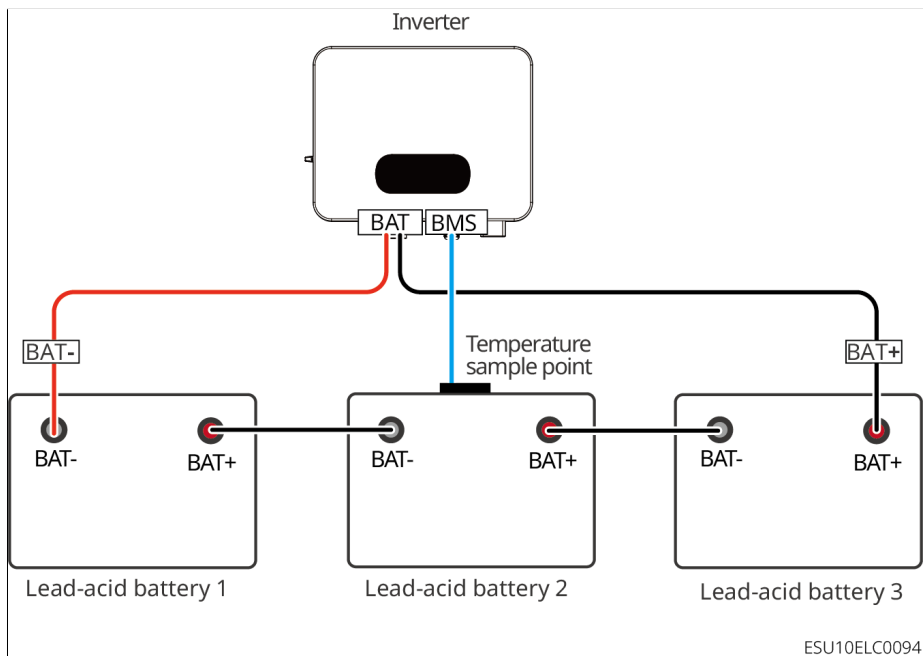

## 6.7 Connecting the AC Cable

**⚠ WARNING**

- The residual current monitoring unit (RCMU) is integrated into the inverter to avoid that the residual current exceeds the limit. The inverter will disconnect with the utility grid quickly once it found the residual current exceeds the limit.
- When wiring, ensure that the AC cable is completely matched with the "BACKUP", "ON-GRID", "GEN", and grounding ports of the AC terminal. Incorrect cable connection will lead to equipment damage.
- Ensure that the whole cable cores are inserted into the terminal holes, and no part of the cable core can be exposed.
- Ensure that the insulation board is inserted into the AC terminal tightly.
- Ensure that the cables are connected securely. Otherwise it will cause damage to the inverter due to overheat during its operation.

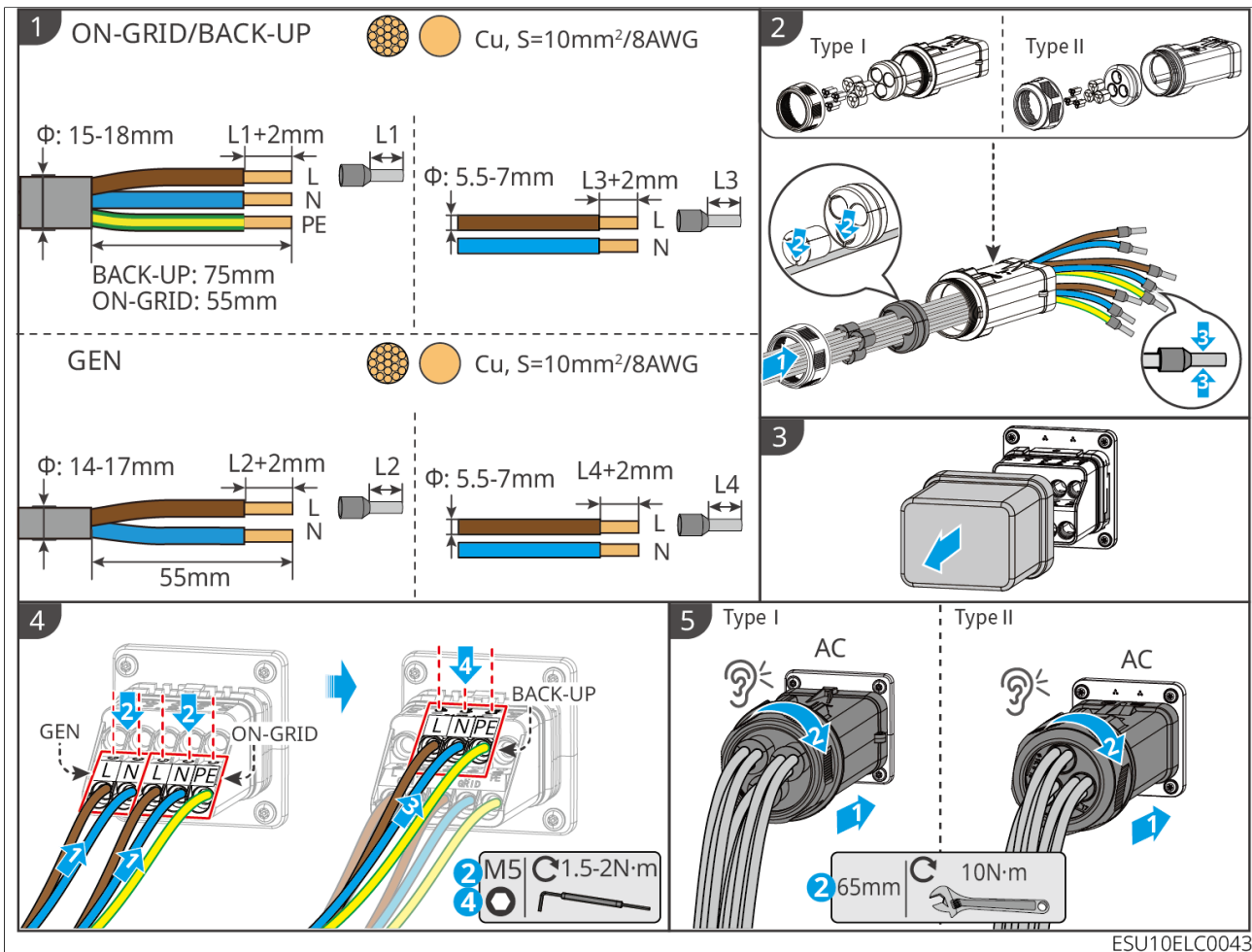

Inverter AC cover disassembly (optional)

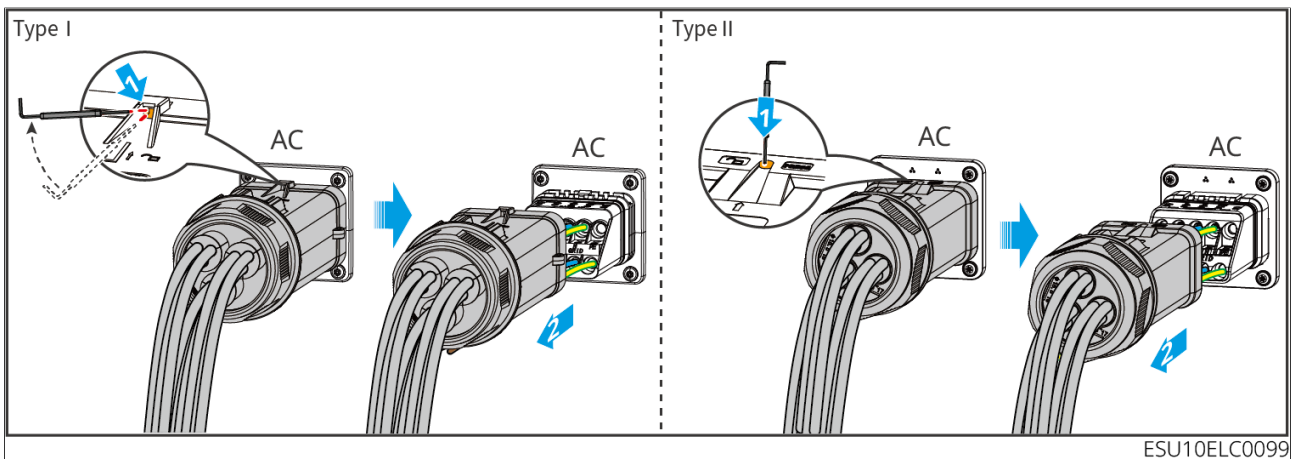

## 6.8 Connecting the Meter Cable

### NOTICE

- Contact the manufacturer for additional smart meters if multiple inverters are connected.
- Ensure that the CT is connected in the correct direction and phase sequences, otherwise the monitoring data will be incorrect.
- Ensure all cables are connected correctly, tightly, and securely. Inappropriate wiring may cause poor contacts and damage the equipment.
- In areas at risk of lightning, if the meter cable exceeds 10m and the cables are not wired with grounded metal conduits, you are recommended to use an external lightning protection device.

### Wiring of GMK110

### NOTICE

- Outer diameter of the AC cable should be smaller than the holes diameter of the CT, so that the AC cable can be threaded through the CT.
- To ensure accurate current detection, the CT cable is recommended to be shorter than 30m.
- Do not use network cable as the CT cable, otherwise the smart meter may be damaged due to high current.
- The CTs vary slightly in dimensions and appearance among different models, but they are installed and connected in the same way.

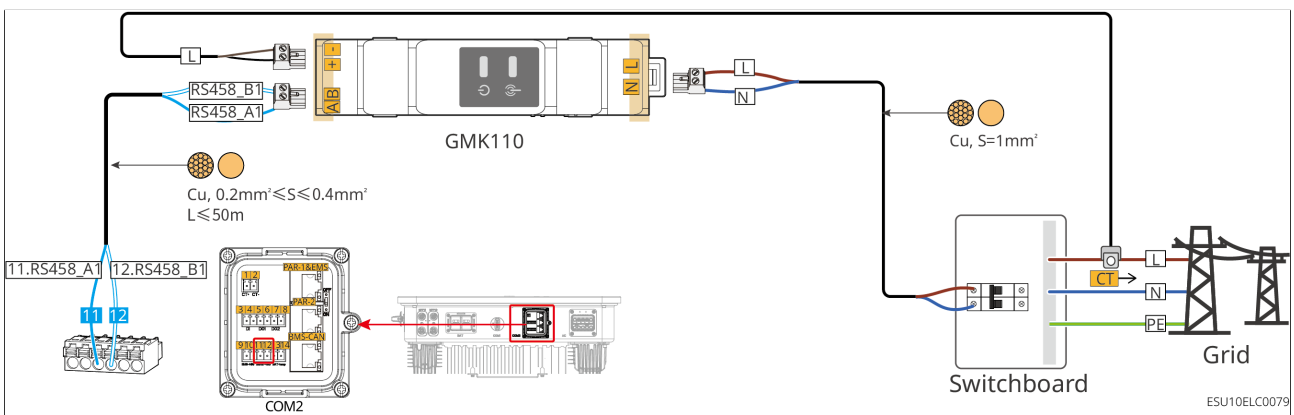

## Connection steps

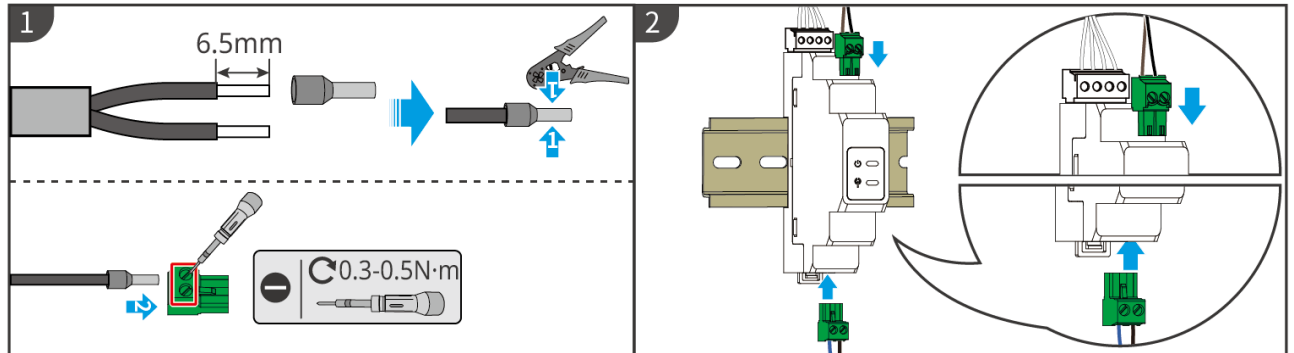

► GMK110: CT x 1; GMK110D: CT x 2

GMK10ELC0002

## Wiring of GMK110

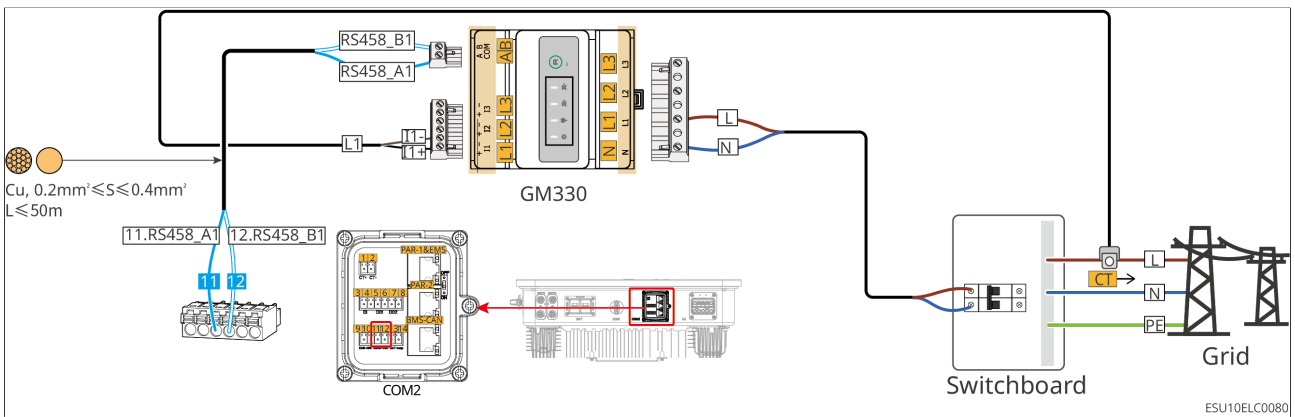

### Connection steps

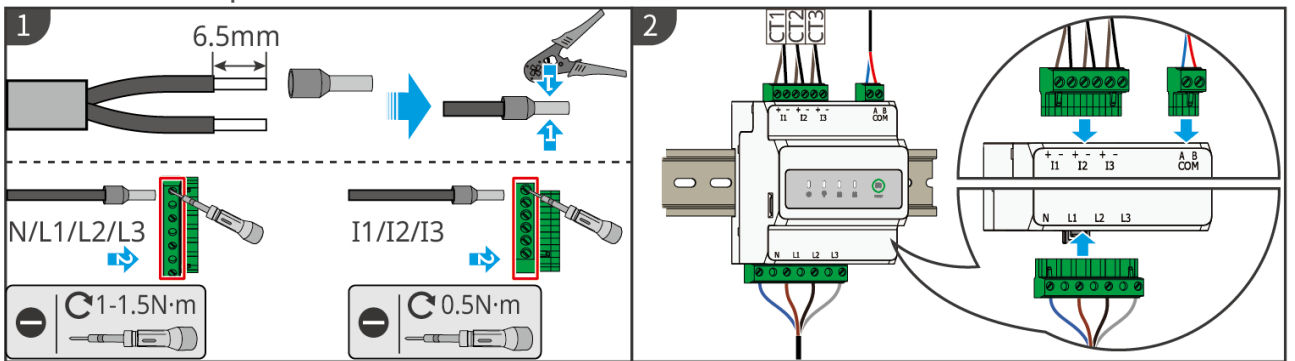

### Installing the CT (Type I)

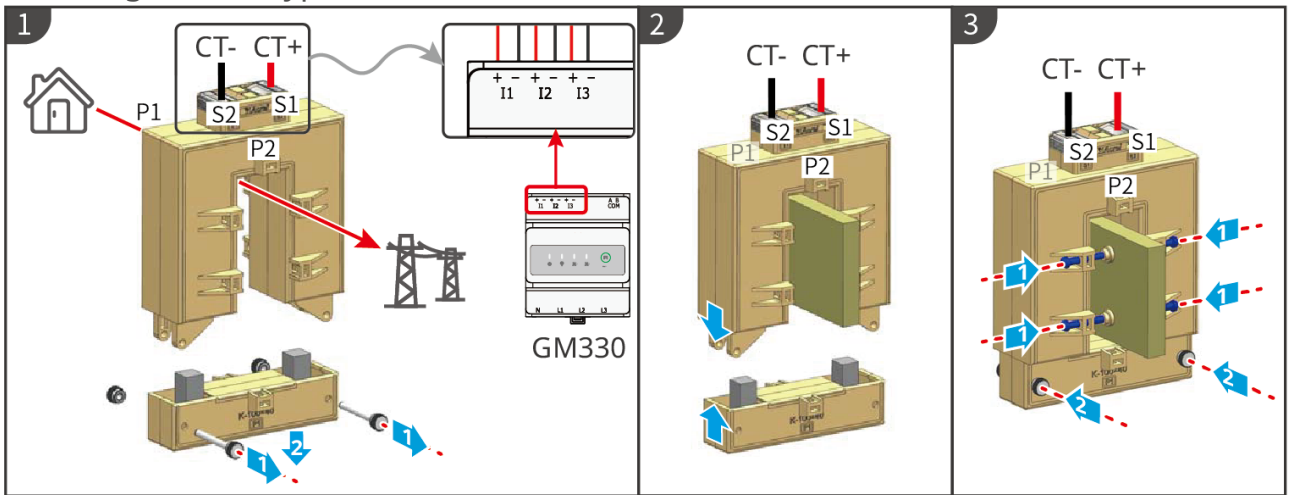

### Installing the CT (Type II)

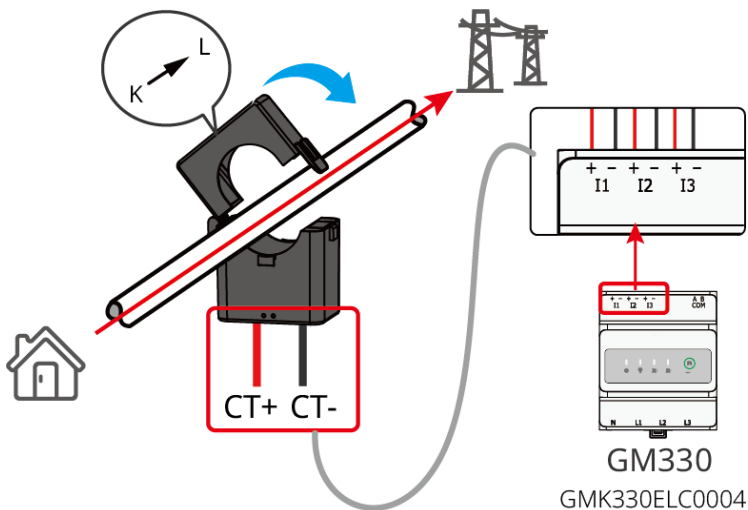

## 6.9 Connecting the Inverter Communication Cable

### NOTICE

- The communication functions are optional. Connect the cables based on actual needs.
- The inverter supports parameter setting via Bluetooth nearby. It also supports connecting to mobile phones or WEB interfaces through communication modules such as WiFi, LAN and 4G to set device-related parameters, view device operation information and error messages, and keep abreast of the system status in a timely manner.
- Please use the WiFi/LAN Kit-20 module in single inverter system. When the system contains multiple inverters in parallel to the network, the master inverter needs to be installed with Ezlink3000 module for networking.
- If you need to use the remote shutdown function, please turn it on in the SolarGo App after wiring is completed.
- Do not turn on the remote shutdown function in the SolarGo App if the inverter is not connected to a remote shutdown device, otherwise the inverter will be unable to operate on-grid.
- In a parallel system, please connect the communication cable to the master inverter to achieve the remote shutdown function, otherwise, the function will not work.

Communication Description



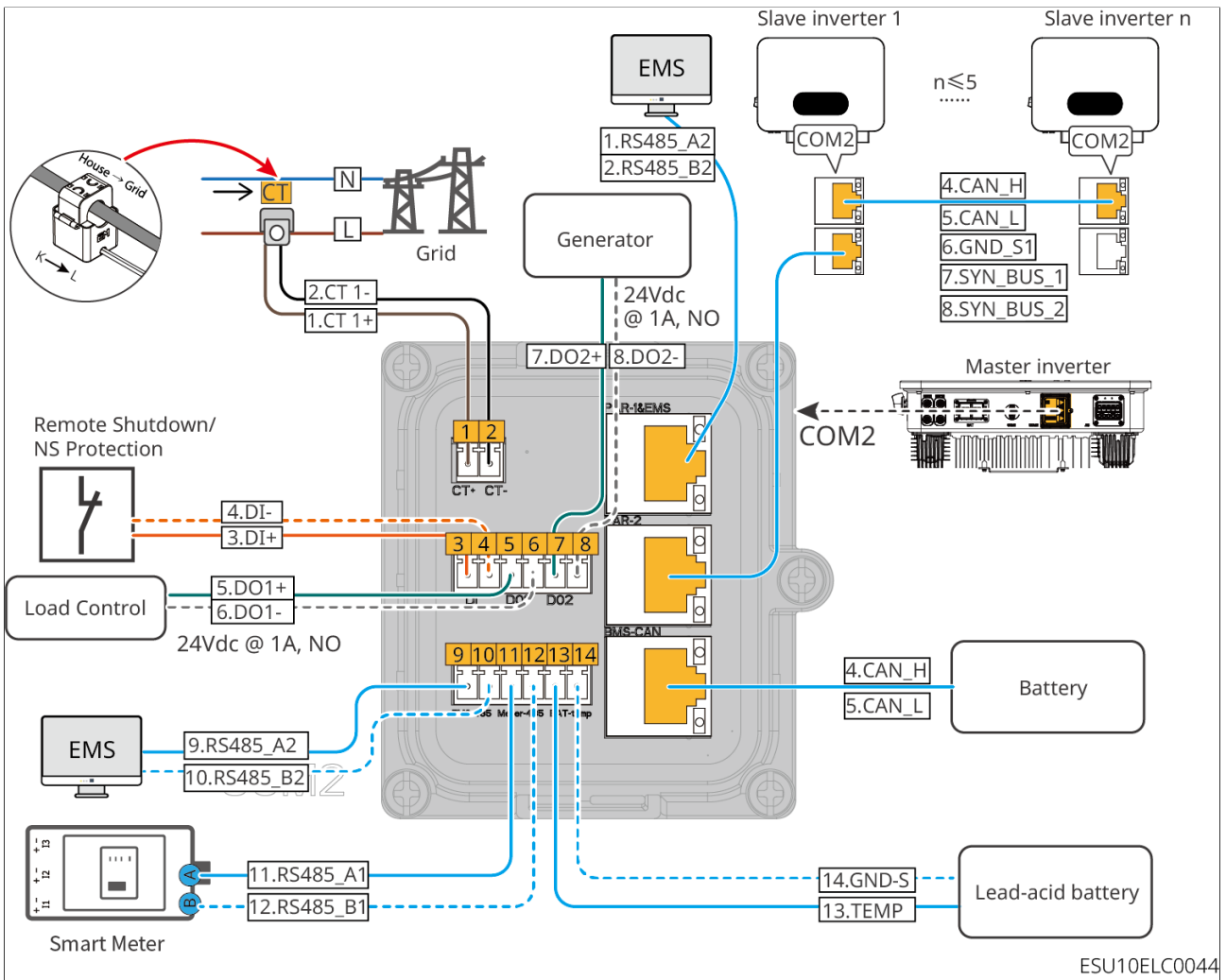

Number	Function	Description
1-2	CT connection port	Connecting the CT communication cable.

Number	Function	Description
3-4	Remote Shutdown Rapid Shutdown NS Protection	<p>Provides signal control port to control equipment remote shutdown or realize NS protection function.</p> <p><b>Rapid shutdown:</b> In the rapid shutdown system, the transmitter is used in conjunction with a receiver to achieve the rapid shutdown of the system. The receiver maintains the component output by receiving signals from the transmitter. The transmitter can be external or built into the inverter. In the event of an emergency, the component can be shut down by enabling an external trigger to stop the transmitter.</p> <p><b>Remote shutdown:</b></p> <ul style="list-style-type: none"> <li>• In the event of an accident, the equipment can be shut down.</li> <li>• Remote shutdown devices need to be normally closed switches.</li> </ul>
5-6	Load control	<ul style="list-style-type: none"> <li>• It supports connection with dry contact signals to achieve functions such as load control. The capacity of the DO contact is 12V DC@1A. NO/COM is a Normally Open contact.</li> <li>• It supports the connection of SG Ready heat pumps and controls the heat pumps through dry contact.</li> <li>• Supported operating modes: <ul style="list-style-type: none"> <li>◦ Operating mode 2 (signal: 0:0 ): energy saving mode. In this mode, the heat pump operates in energy saving mode.</li> <li>◦ Operating Mode 3 (Signal: 0:1 ): It's recommended to turn on. In this mode, the heat pump increases the hot water reserve while maintaining the existing operation to store heat.</li> </ul> </li> </ul>

Number	Function	Description
7-8	Generator start/stop control control port	Access to generator control signals is supported.
9-10	EMS communication port	It's used to connect third-party EMS devices that support RS485 communication. The third-party EMS devices are not supported to be connected in the parallel scenario. Note: It's the same line as EMS in PAR-1 & EMS port.
11-12	Smart meter communication	Connecting to external smart meters through RS485 communication is supported.
13-14	Lead-acid temperature measurement port	Temperature sensing wire to connect lead-acid temperature measurement
PAR-1 & EMS	Parallel communication port 1 EMS communication port (PAR-1&EMS)	<ul style="list-style-type: none"> <li>• CAN and BUS: parallel communication ports, using CAN communication to connect other inverters in the on-grid network; using BUS to control the parallel inverters in the on-grid and off-grid status.</li> <li>• RS485: used to connect third-party EMS devices that support RS485 communication. The third-party EMS devices are not supported to be connected in the parallel scenario.</li> </ul>
PAR-2	Parallel operation communication port 2 (PAR-2)	For parallel communication, using CAN communication to connect to other inverters is supported; BUS is used to control the inverters in the on-grid and off-grid status.
BMS-CAN	Battery BMS Communications	When connected to a lithium-ion battery, it is used to connect the battery system BMS communication line and supports the use of CAN signal communication.

Connecting the communication cable.

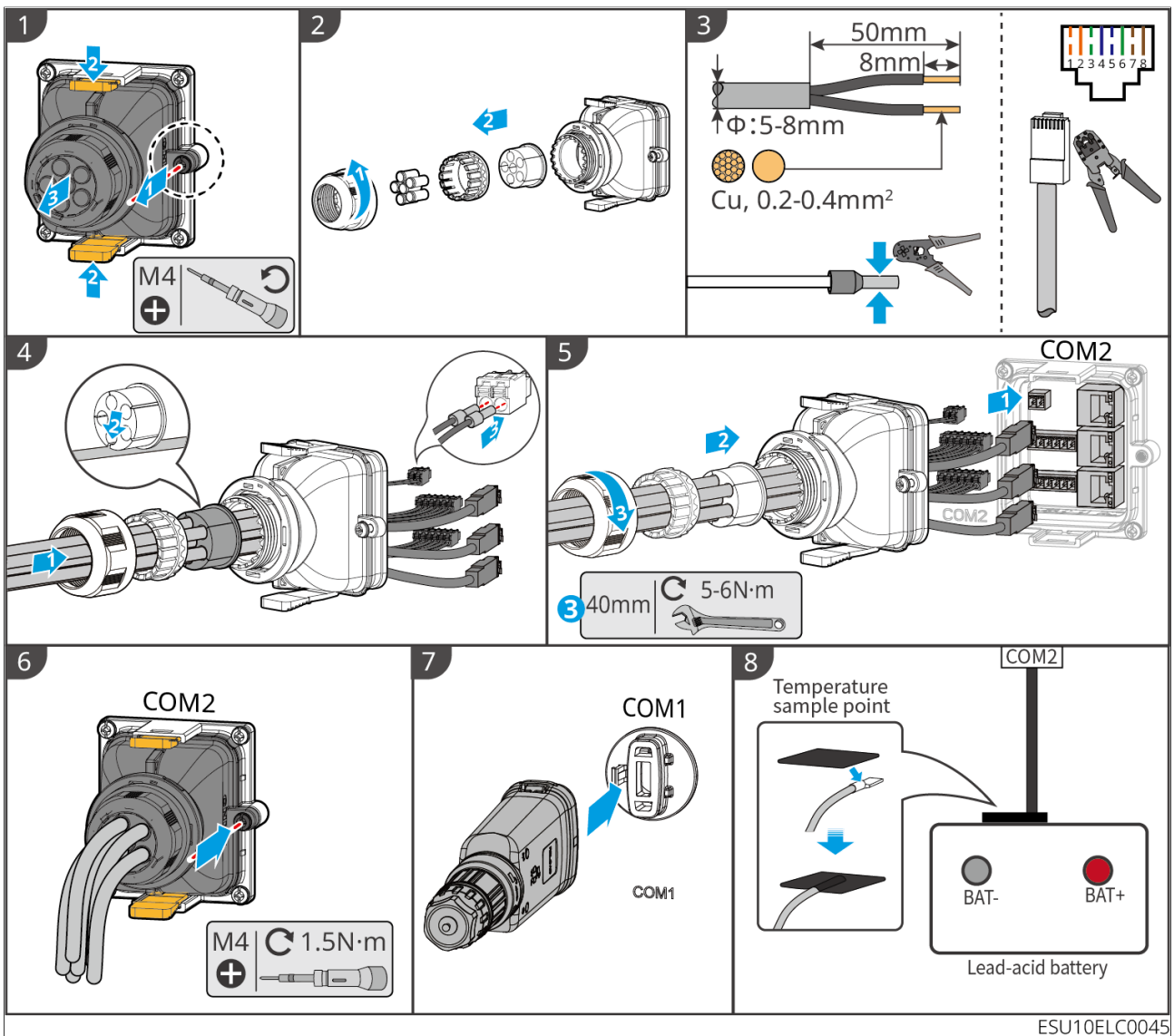

ESU10ELC0045

## 6.10 Installing the Battery Cover

### 6.10.1 LX A5.0-10

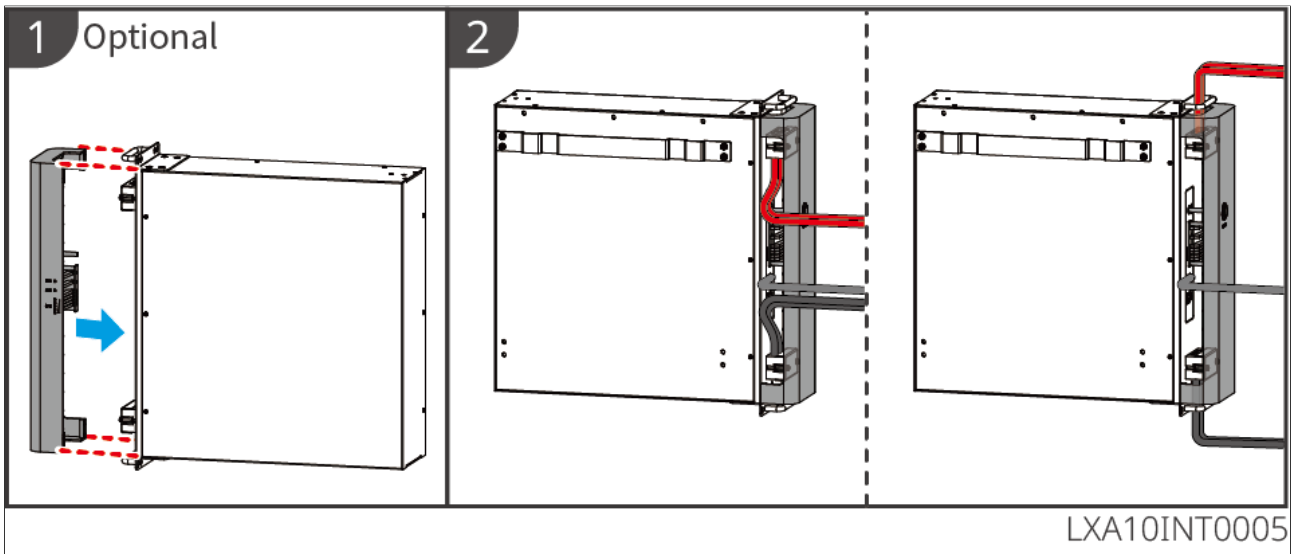

### 6.10.2 LX A5.0-30

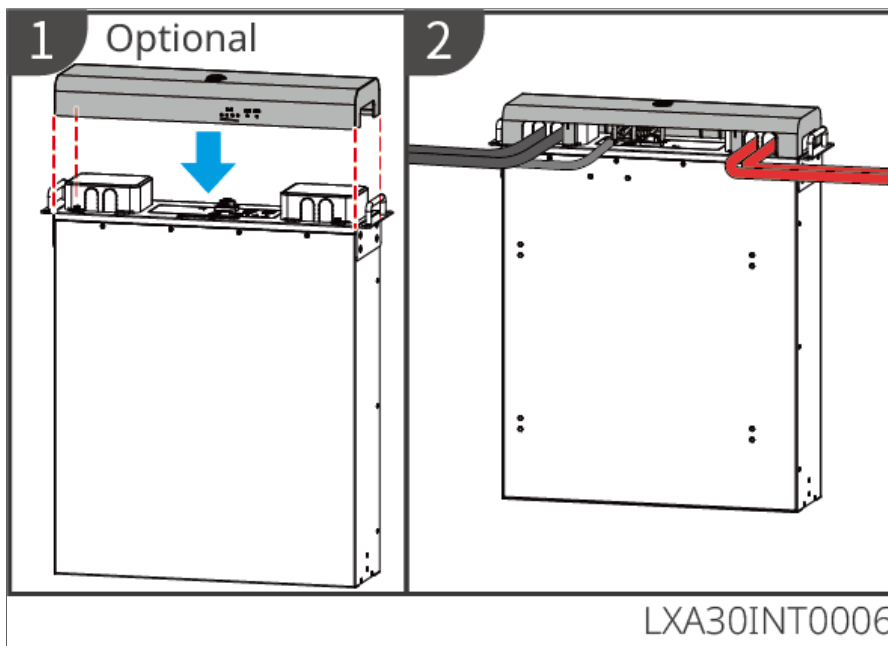

### 6.10.3 LX U5.0-30

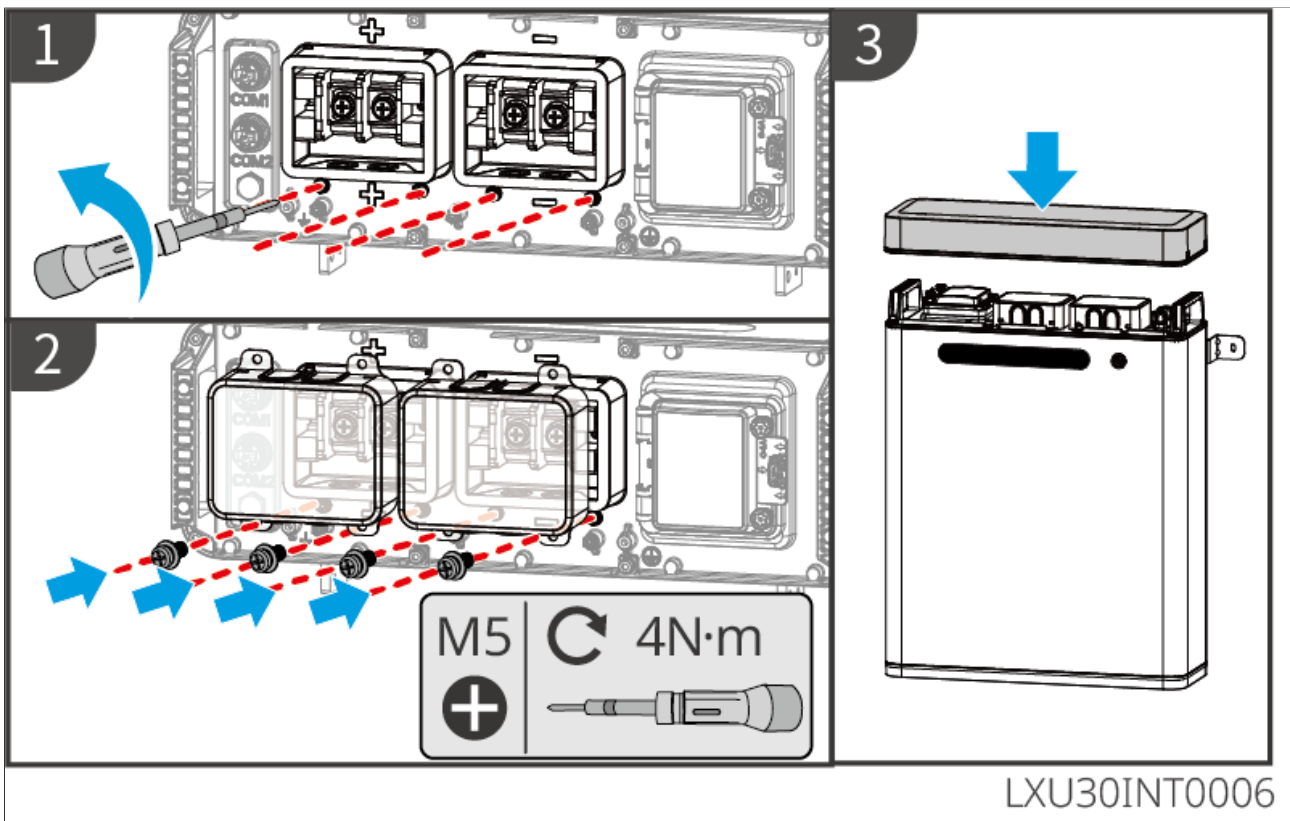

#### 6.10.4 GW14.3-BAT-LV-G10

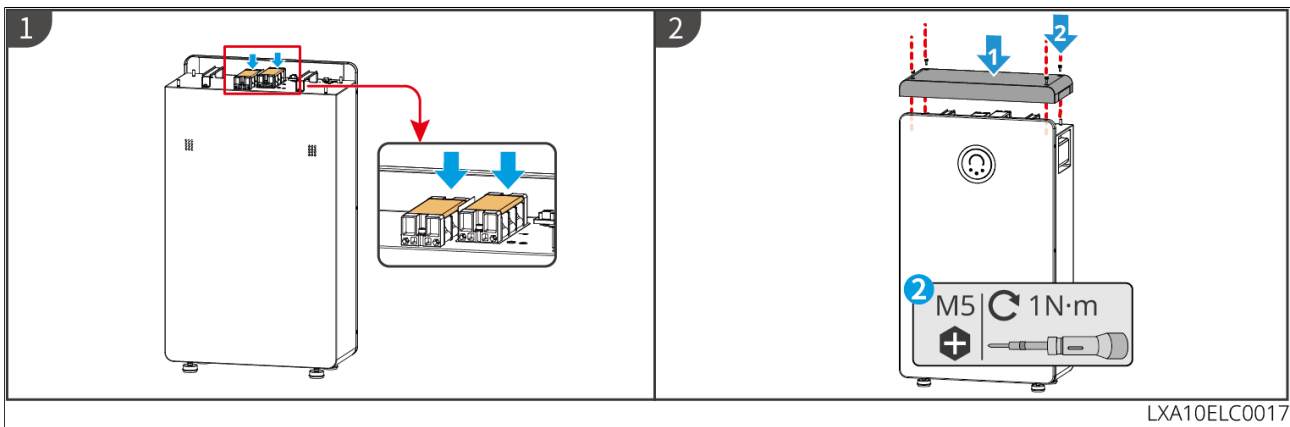

## 7 System Commissioning

### 7.1 Check Before Power ON

No.	Check Item
1	The inverter is firmly installed in a clean place where is well-ventilated and easy to operate.
2	Ensure that the ground wire, DC wire, AC wire, communication wire, and terminal resistor are connected correctly and securely.
3	The cable binding shall comply with routing requirements, with reasonable distribution and no damage.
4	Unused wire holes and ports should connect with reliable terminals provided with the accessories and be sealed up.
5	The used cable holes are sealed.
6	The voltage and frequency at the connection point meet the inverter grid connection requirements.

### 7.2 Power ON



- When there are multiple inverters in the system, please ensure that all slave inverter AC sides are powered on within one minute after the master inverter AC side is powered on.
- Battery black start scenarios:
  - The inverter needs to be activated by battery.
  - When there is no inverter and you need to charge and discharge the battery, etc..
- After the battery system is started, please ensure that the communication between the inverter and the battery system is normal within 15 minutes. If the inverter cannot communicate with the battery system, the battery system breaker will be disconnected automatically, and the battery system will be powered off.
- When multiple batteries are connected in parallel in the system, starting any one battery will start all batteries.
  - GW14.3-BAT-LV-G10: After the battery is powered off and then powered on again, each battery must be restarted individually, or any battery can be started after waiting 15 minutes, and all batteries will start.

### **Power on process**

1. Turn on the BACK-UP circuit breaker.
2. Turn on the ON-GRID circuit breaker.
3. (Optional) Turn on the GEN circuit breaker.
4. (Selected in accordance with local laws and regulations) Turn on the circuit breaker between the PV module and the inverter.
5. Turn on the DC switch of the inverter.
6. (Selected in accordance with local laws and regulations) Turn on the switch between the inverter and the battery.
7. Turn on the battery switch.
8. Turn on the battery system switch (LX A5.0-10, LX A5.0-30). Turn on the battery system integration circuit breaker (LX U5.0-30, GW14.3-BAT-LV-G1).
9. (LX U5.0-30 and GW14.3-BAT-LV-G1 only) Press the battery system button.

### Single Inverter System



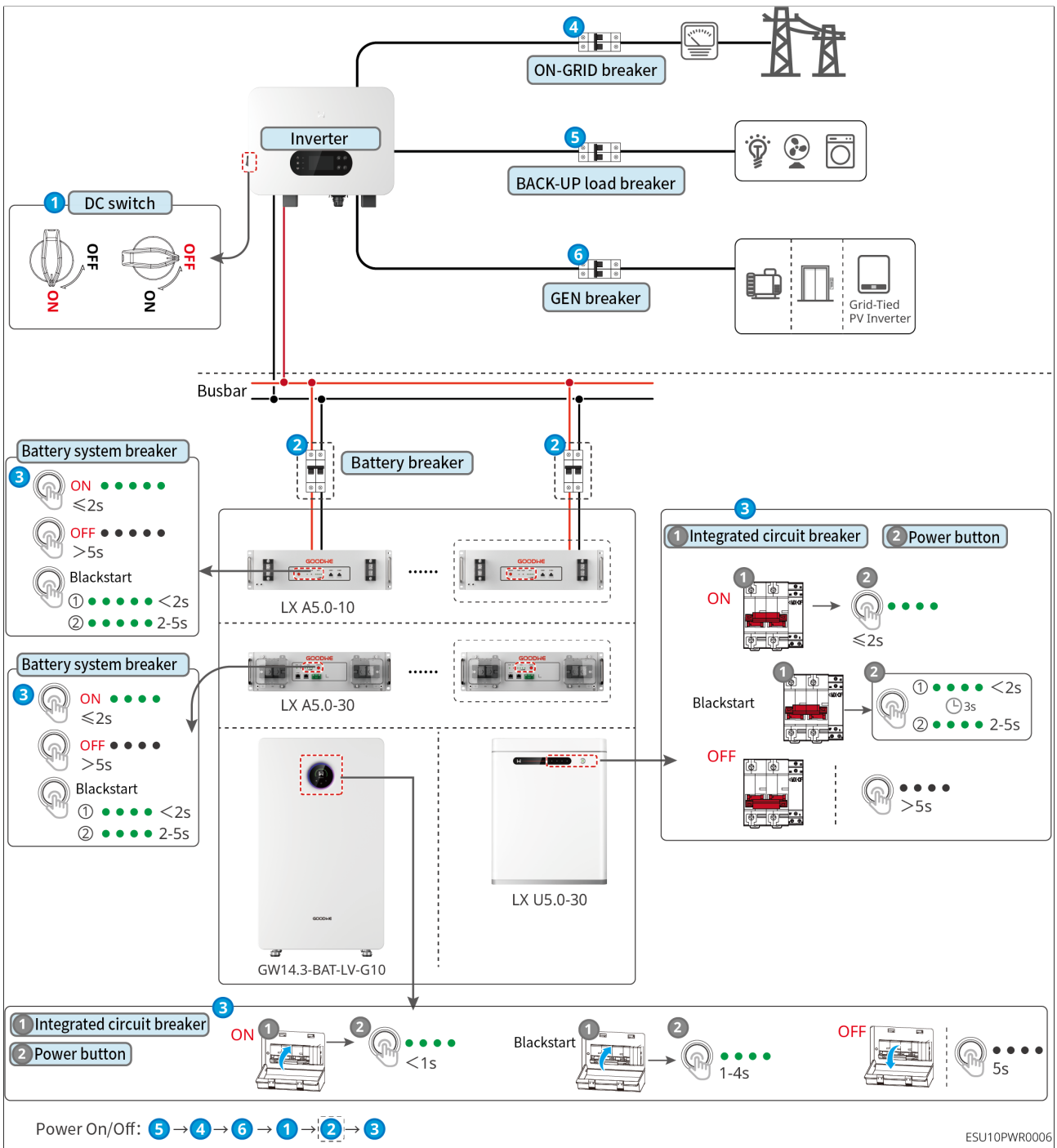



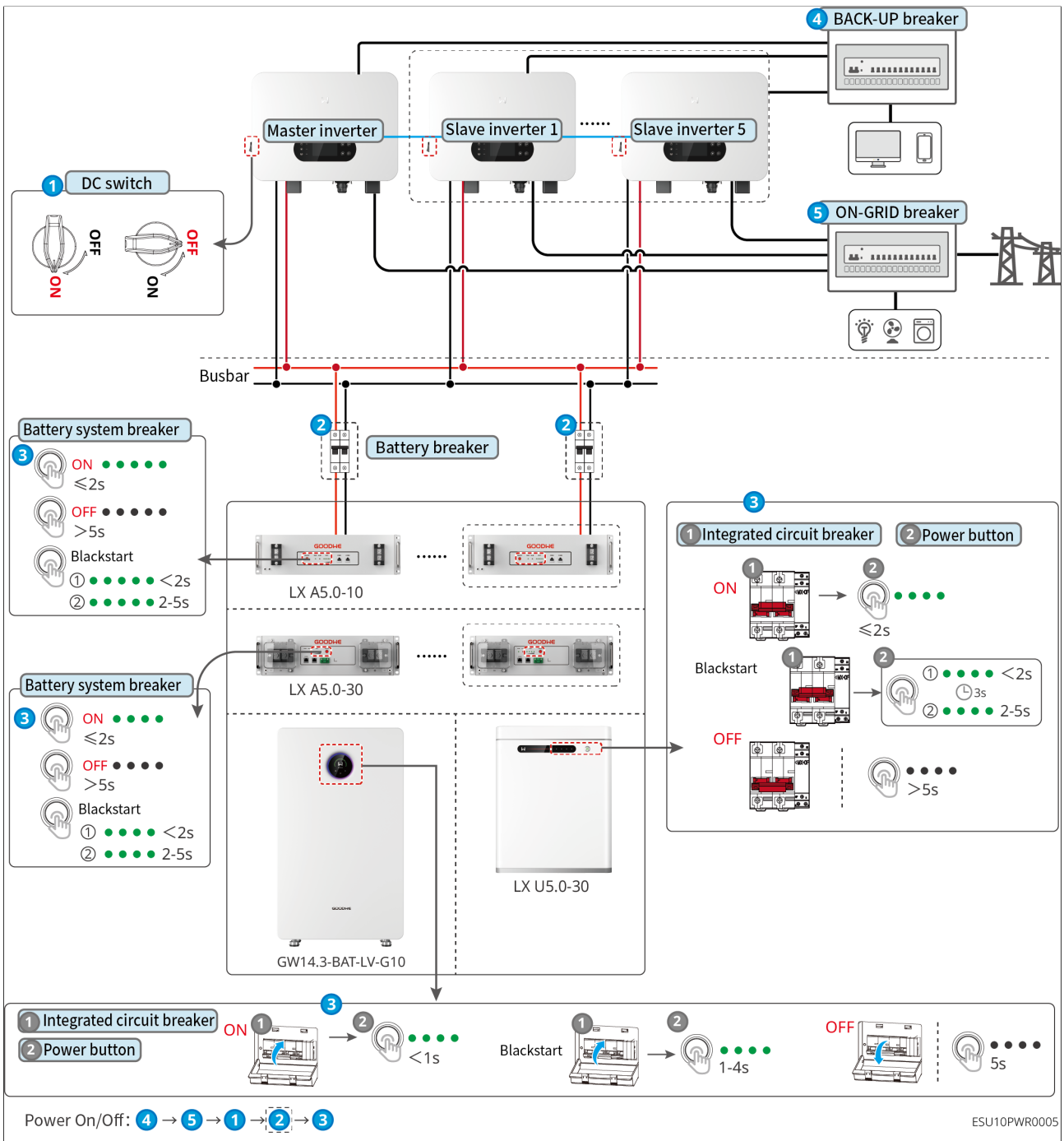













## Parallel System



## 7.3 Indicators







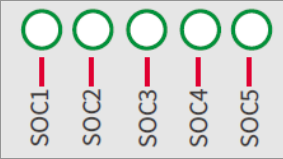

### 7.3.1 Inverter Indicators

Indicator	Status	Description
		The inverter is starting up and in the self-check mode.
		The inverter is powered on and in the standby mode.
		BACK-UP output overload.
		System failure.
		LCD ON: The inverter is powered on and in the standby mode. LCD OFF: The inverter is powered off.
		The grid is abnormal, and the power supply to the BACK-UP port of the inverter is normal.
		The grid is normal, and the power supply to the BACK-UP port of the inverter is normal.
		The BACK-UP port has no power supply.
		The monitoring module of the inverter is resetting.
		The inverter fails to connect with the communication Termination.
		Communication fault between the communication termination and server.
		The monitoring of the inverter operates well.
		The monitoring module of the inverter has not been started yet.

## 7.3.2 Battery Indicators

### 7.3.2.1 LX A5.0-10

Normal status







<p style="text-align: center;"><b>SOC Indicator</b></p> 	<p style="text-align: center;"><b>RUN light</b></p> 	<p style="text-align: center;"><b>Battery system status</b></p>
<p>The SOC indicator represents the battery system's usable energy.</p> <p>  SOC&lt;5%   5%≤SOC&lt;25%   25%≤SOC&lt;50%   50%≤SOC&lt;75%   75%≤SOC&lt;95%   95%≤SOC≤100% </p>	<p>Green light flashes 1 time/s.</p> <p>Green light flashes 2 time/s.</p> <p>Green light is on.</p>	<p>The battery system is in the standby mode.</p> <p>The battery system is in an idle state.</p> <p>The battery system is in the charging state.</p>
<p>The last SOC indicator flashes 1 time/s.</p> <ul style="list-style-type: none"> <li>• When 25% ≤ SOC &lt; 50%, SOC2 flashes.</li> <li>• When 25% ≤ SOC &lt; 50%, SOC2 flashes.</li> <li>• When 25% ≤ SOC &lt; 50%, SOC2 flashes.</li> <li>• When 25% ≤ SOC &lt; 50%, SOC2 flashes.</li> <li>• When 95% ≤ SOC &lt; 100%, SOC5 flashes.</li> </ul>	<p>Green light is on.</p>	<p>The battery system is in discharging status.</p>

### Abnormal status

<p><b>ALM Light</b></p> 	<p><b>Battery system status</b></p>	<p><b>Description</b></p>
<p>Red light blinks 1 time/s.</p>	<p>Battery system alarms.</p>	<p>Once an alarm occurs, the battery system will perform a self-check. After the self-checking is complete, the battery system enters into an operation or fault mode.</p>

<b>ALM Light</b> 	<b>Battery system status</b>	<b>Description</b>
Red light is on.	The battery system has malfunctioned.	Check the SOC indicator status to identify the fault type and handle the problem as recommended in the Troubleshooting section.

### 7.3.2.2 LX A5.0-30, LX U5.0-30



<b>Indicator</b>	<b>System Status</b>
	No SOC indicator shows green. SOC=0%
	The first SOC indicator shows green. $0% < SOC \leq 25%$
	The first two SOC indicators are green. $0% < SOC \leq 25%$
	The first three SOC indicators are green. $0% < SOC \leq 25%$
	All SOC indicators are green. $0% < SOC \leq 25%$
 RUN light	Green light is on. The battery system is working normally.
	Green light flashes 1 time/s. The battery system is in the standby mode.
	Green light flashes 3 time/s. The PCS communication is lost.
	Green flashes slowly. The battery system gives an alarm, and conducts a self-check. After the self-checking is over, it will change to normal working status or fault status.
 ALM Light	Red light is on. Check the SOC indicator status to identify the fault type and handle the problem as recommended in the Troubleshooting section.

### 7.3.2.3 GW14.3-BAT-LV-G10



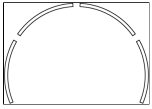
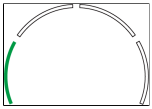
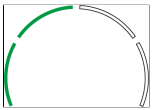
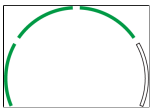
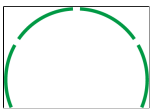

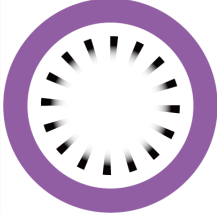
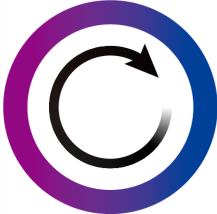

Normal status

Indicat or name	Indicator status		Corresponding to other light statuses	System Status
SOC Indicat or	 	SOC indicator green and steady on.	/	SOC=0% $0% < SOC \leq 25%$ $25% < SOC \leq 50%$ $50% < SOC \leq 75%$ $75% < SOC \leq 100%$
	  	SOC indicator flashing green.		The battery system is in discharging status.

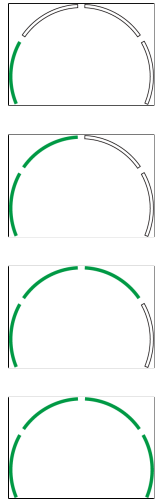
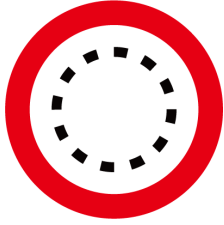

Indicator or name	Indicator status	Corresponding to other light statuses	System Status
Operation indicator light + touch button		White light is on.  Blue-purple breathing light	The system is working normally.
		White light flashes.  Blue-purple marquee	The system is preparing.
Communication Light		White light is on. /	PCS communication normal

Abnormal status

Indicator or name	Indicator status	Corresponding to other light statuses	System Status
SOC Indicator	 <p>SOC indicator shows green.</p>	 Red light flashes.  Power Off  Red light is on.	Check the SOC indicator status to identify the fault type and handle the problem as recommended in the Troubleshooting section.
Communication Light	 <p>Power Off /</p>		The PCS communication is lost.
System alarm light	 <p>White light is on. /</p>		System alarms. Undervoltage faults 2, 3, and 4





### 7.3.3 Smart Meter Indicator

#### 7.3.3.1 GMK110

Type	Status	Description
Power light 	Steady on	The smart meter is power on.
	Off	The smart meter has been powered off.
Communication indicator 	Blinks.	Meter communication is normal.
	Off	Meter communication is abnormal or has no communication.













### 7.3.3.2 GM330

Type	Status	Description
Power light 	On	Power on, no RS485 communication.
	Blinks.	Power on, RS485 communication works properly.
	Off	The smart meter has been powered off.
Communication indicator 	Off	Reserved.
	Blinks.	Press the Reset button for more than 5 seconds, power light, buying or selling electricity indicator light flash: Reset the meter.
Importing or exporting indicator 	On	Importing from the grid.
	Blinks.	Exporting to the grid.
	Off	Exporting to the grid.
	Reserved.	

### 7.3.4 Smart Dongle Indicator

#### 7.3.4.1 WiFi/LAN Kit-20



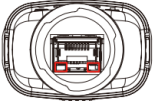

Indicator	Status	Description
Power light 		On: The smart dongle has been powered on.
		Power Off: The smart dongle is not powered on.
Communication indicator 		On: Communication in WiFi mode or LAN mode is normal.
		Blinks 1 time: The smart dongle Bluetooth has been turned on, and is waiting for connecting to the SolarGo App.
		Blinks 2 times: The smart dongle is not connected to the router.
		Blinks 4 times: The smart dongle is communicating normally with the router, but has not been connected to the server.





Indicator	Status	Description
		Blinks 6 times: The smart dongle is recognizing the connected device.
		Off: The software of the smart dongle is resetting or is not powered on.

Indicator	Color	Status	Description
Communication indicator in LAN Port 	Green	On	The 100Mbps wired network is normally connected.
		Off	<ul style="list-style-type: none"> <li>The Ethernet cable is not connected.</li> <li>Fail to connect the 100Mbps wired network.</li> <li>The 10Mbps wired network is normally connected.</li> </ul>
	Yellow	On	The 10/100Mbps wired network is normally connected, but no communication data is received or transmitted.
		Blinks.	The communication data is being transmitted or received.
		Off	The Ethernet cable is not connected.

Button	Description
Reload	Press and hold for 0.5 to 3 seconds to reset the Smart Dongle. Press and hold for 6 to 20 seconds to restore the Smart Dongle to factory settings.







### 7.3.4.2 4G Kit-CN-G20 & 4G Kit-CN-G21

Indicator	Status	Description
Power light 		On: The smart dongle has been powered on.
		Power Off: The smart dongle is not powered on.
		On: The smart dongle is communicating normally with the server.
		Blinks 2 times: Smart dongle is not connected to the base station.

Indicator	Status	Description
Communication indicator 		Blinks 4 times: The smart dongle is connected to the base station, but has not been connected to the server.
		Blinks 6 times: The smart dongle is disconnected from the inverter.
		Off: The software of the smart dongle is resetting or is not powered on.

Button	Description
Reload	Short press for 0.5 to 3 seconds to restart the smart dongle.
	Press and hold for 6 to 20 seconds to restore the Smart Dongle to factory settings.

### 7.3.4.3 Ezlink3000

Indicator / Silkscreen	Color	Status	Description
Power light 	Blue		Blink = The smart dongle is working properly.
			OFF = The smart dongle is powered off.
Communication indicator 	Green		ON = The smart dongle is connected to the server.
			Blink 2 = The smart dongle is not connected to the router.
			Blink 4 = The smart dongle is connected to the router, but not connected to the server.
RELOAD	-	-	<ul style="list-style-type: none"> <li>• Short press for 1 to 3 seconds to restart the smart dongle.</li> <li>• Long press for 6 to 10 seconds to restore factory settings.</li> </ul> Double press quickly to activate Bluetooth signal (only lasts for 5 minutes).

## 8 Rapid System Configuration

### 8.1 Downloading the App

#### 8.1.1 Downloading SolarGo App

Make sure that the mobile phone meets the following requirements:

- Mobile phone operating system: Android 5.0 or later, iOS 13.0 or later.
- The mobile phone can access the Internet.
- The mobile phone supports WLAN or Bluetooth.

#### NOTICE

Once the SolarGo App has been installed, you will receive automatic notifications when updates are available.

Method 1: Search SolarGo in Google Play (Android) or App Store (iOS) to download and install the app.



Method 2: Scan the QR code below to download and install the App.

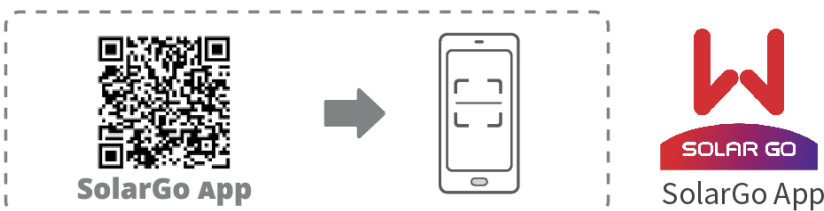

#### 8.1.2 Downloading SEMS+ APP

Make sure that the mobile phone meets the following requirements:

- Mobile phone operating system: Android 6.0 or later, iOS 13.0 or later.
- The mobile phone can access the Internet.
- The mobile phone supports WLAN or Bluetooth.

## Download Method:

### Method 1:

Search SEMS+ in Google Play (Android) or App Store (iOS) to download and install the App.



### Method 2:

Scan the QR code below to download and install the App.



## 8.2 Connecting the inverter via SolarGo

### NOTICE

The device name varies depending on the inverter model or smart dongle type:

- Wi-Fi Kit: Solar-WiFi\*\*\*
- Bluetooth Module: Solar-BLE\*\*\*
- WiFi/LAN Kit-20: WLA-\*\*\*
- Ezlink3000: CCM-BLE\*\*\*; CCM-\*\*\*; \*\*\*

### Connect to the inverter via Bluetooth

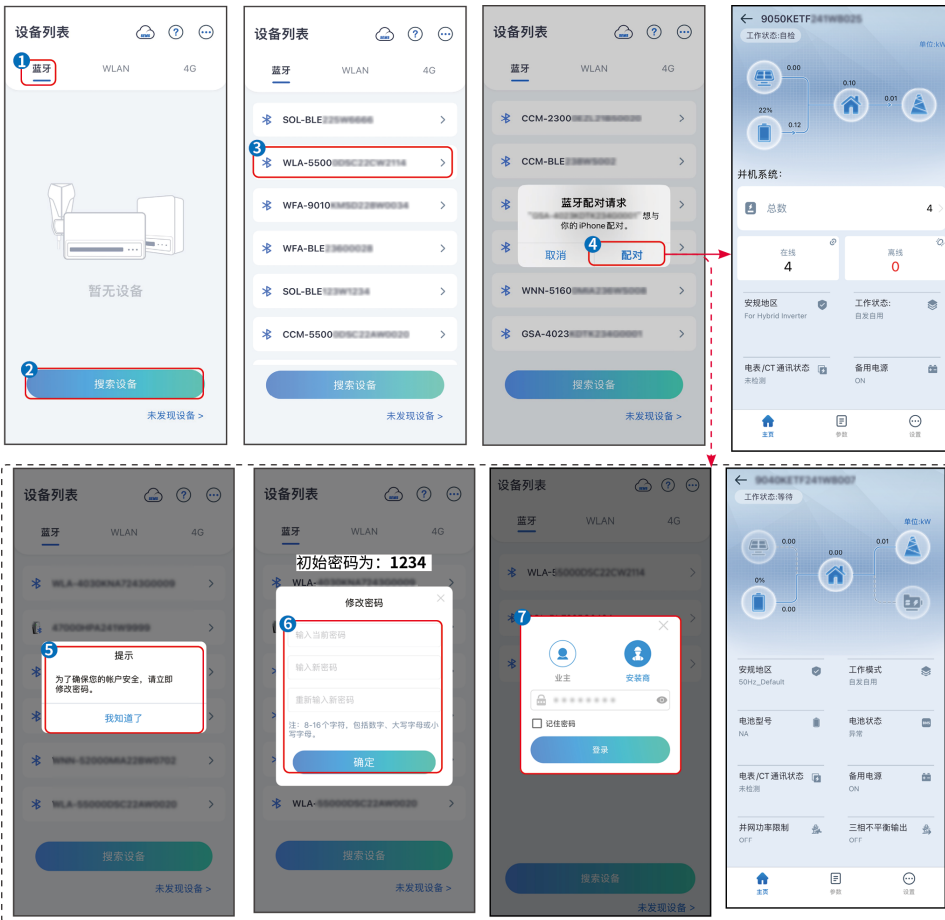

### Connect to the inverter via WiFi

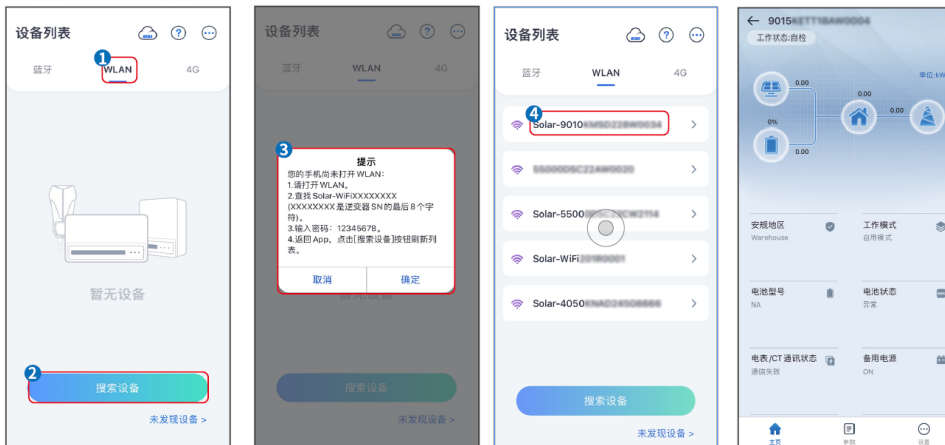

## 8.3 Setting Communication Parameters

## NOTICE

The communication configuration interface may be different if the inverter uses different communication modes or connects different communication modules. Please refer to the actual interface.

### 8.3.1 Setting Privacy and Security Parameters

#### Type I

**Step 1** : Tap **Home > Settings > Communication Setting > Privacy & Security** to set the parameters.

**Step 2** : Set the new password for the WiFi hotspot of the communication module, and tap **Save**.

**Step 3** Open the WiFi settings of your phone and connect to the inverter's WiFi signal (Solar WiFi\*\*) with the new password.

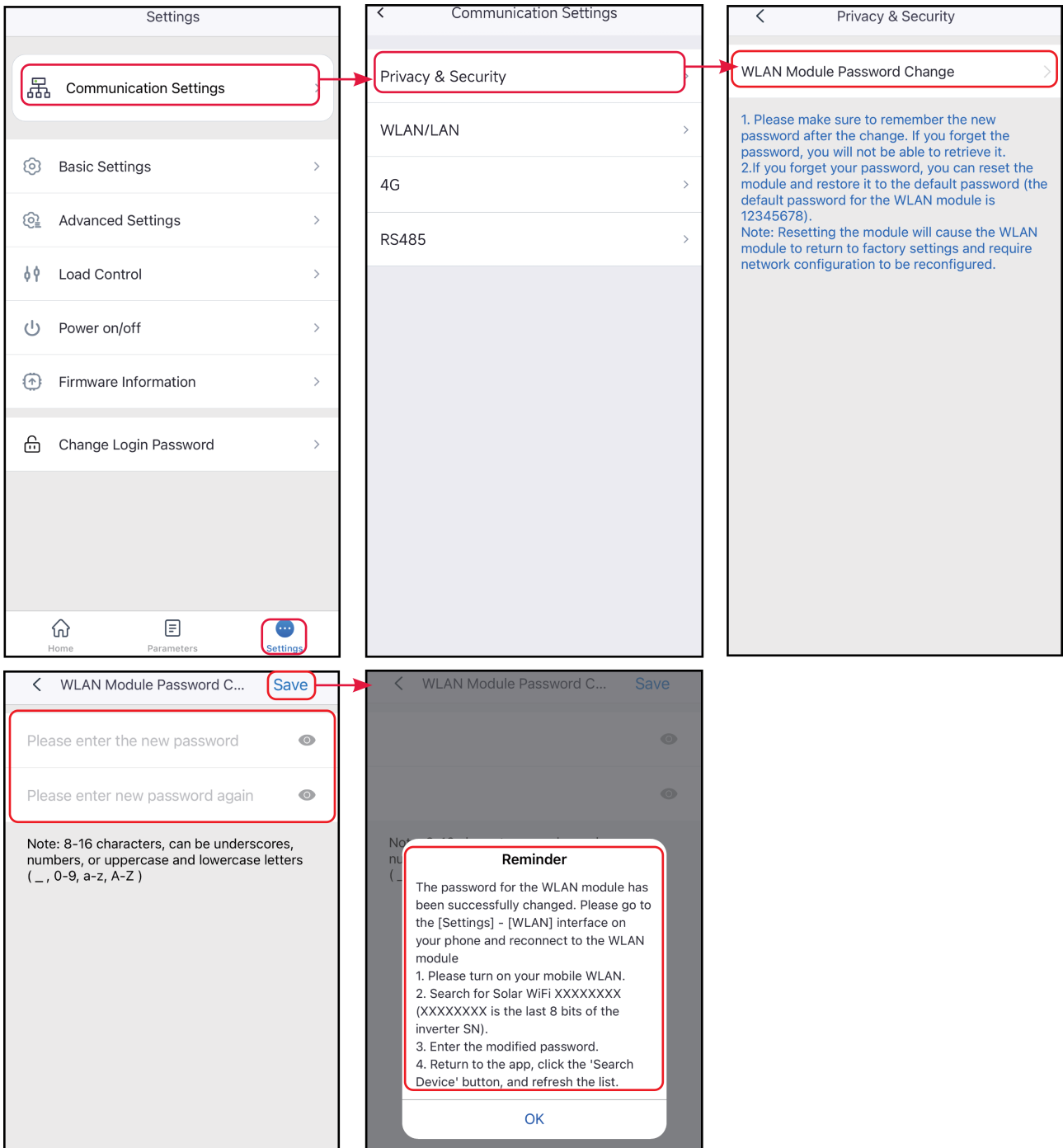

## Type II

**Step 1 :** Tap **Home > Settings > Communication Setting > Privacy & Security** to set the parameters.

**Step 2** Enable Bluetooth Stays On or WLAN Control based on actual needs.



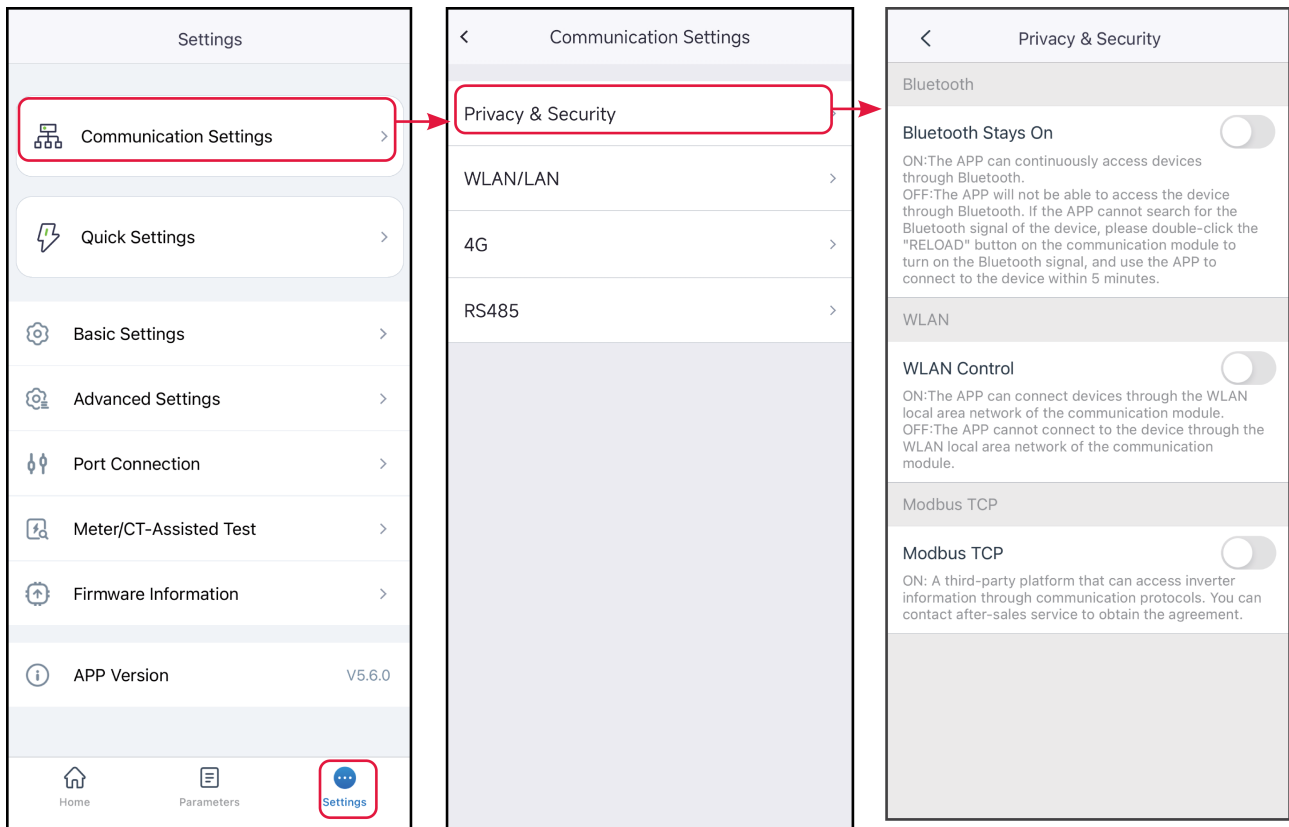

No.	Parameters	Description
1	Bluetooth Stays On	Disabled by default. Enable the function, the bluetooth of the device will be contentious on to keep connected to SolarGo. Otherwise, the bluetooth will be off in 5 minutes, and the device will be disconnected from SolarGo.
2	WLAN Control	Disabled by default. Enable the function, the device and the SolarGo can be connected through the WLAN when they are on the same LAN. Otherwise, they cannot be connected even if they are on the same LAN.
3	Modbus-TCP	Enable the function, the third party monitoring platform can access inverter through Modbus-TCP communication protocol.
4	SSH control Ezlink	After enabling this function, third-party platforms can connect to and control EzLink's Linux system.

### Type III

**Step 1 :** Tap **Home > Settings > Communication Setting > Privacy & Security** to set

the parameters.

**Step 2 : Enable Bluetooth Stays On or Login Password based on actual needs.**

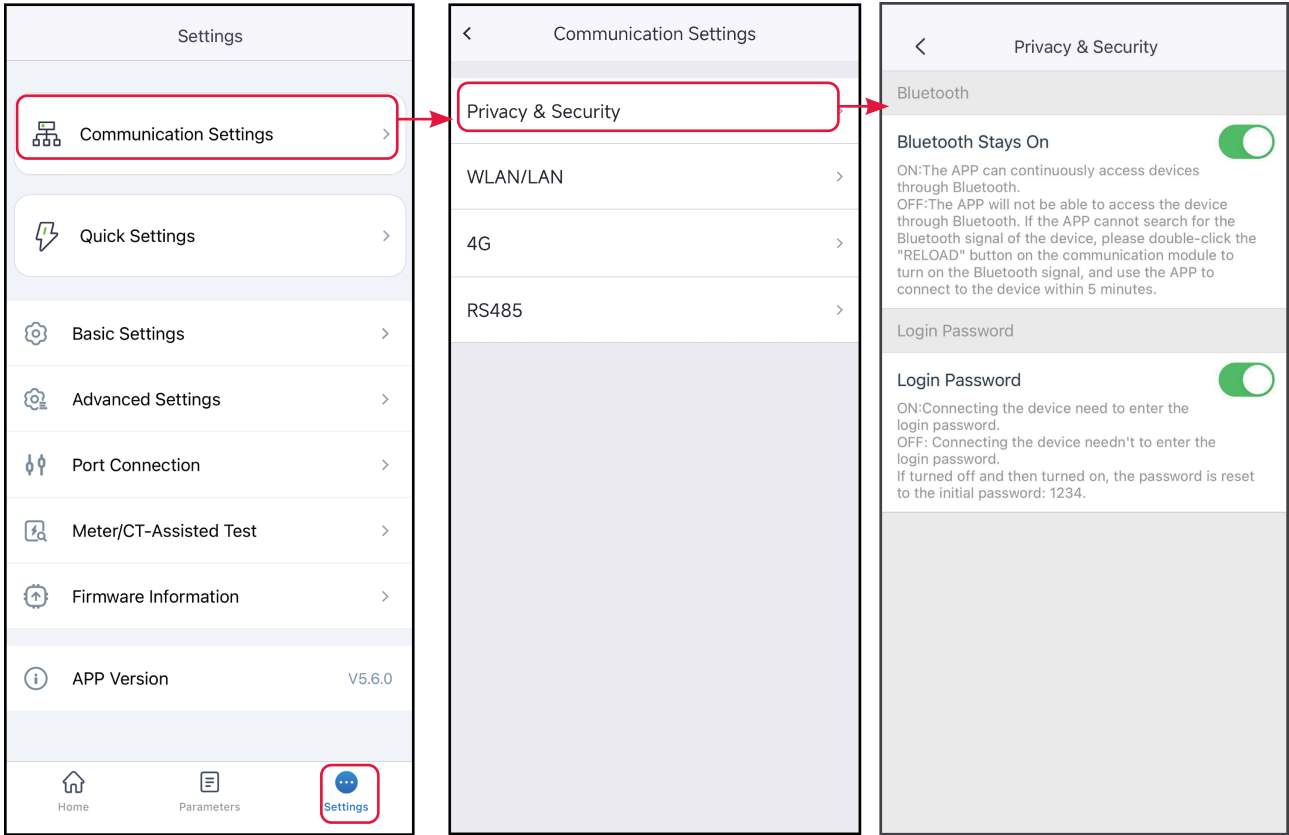

No.	Parameters	Description
1	Bluetooth Stays On	Disabled by default. Enable the function, the bluetooth of the device will be contentious on to keep connected to SolarGo. Otherwise, the bluetooth will be off in 5 minutes, and the device will be disconnected from SolarGo.
2	Password	Disabled by default. Enable the function, you will be prompted to enter the login password when connecting the device to SolarGo. Use the initial password and change it at the first login prompt.

**8.3.2 Setting WLAN/LAN Parameters**

## NOTICE

When the inverter is connected to different communication modules, the communication configuration interface may be different. Please refer to the actual interface.

**Step 1 :** Tap **Home > Settings > Communication Setting > WLAN/LAN** to set the parameters.

**Step 2 :** Configure the WLAN or LAN parameters based on actual needs.

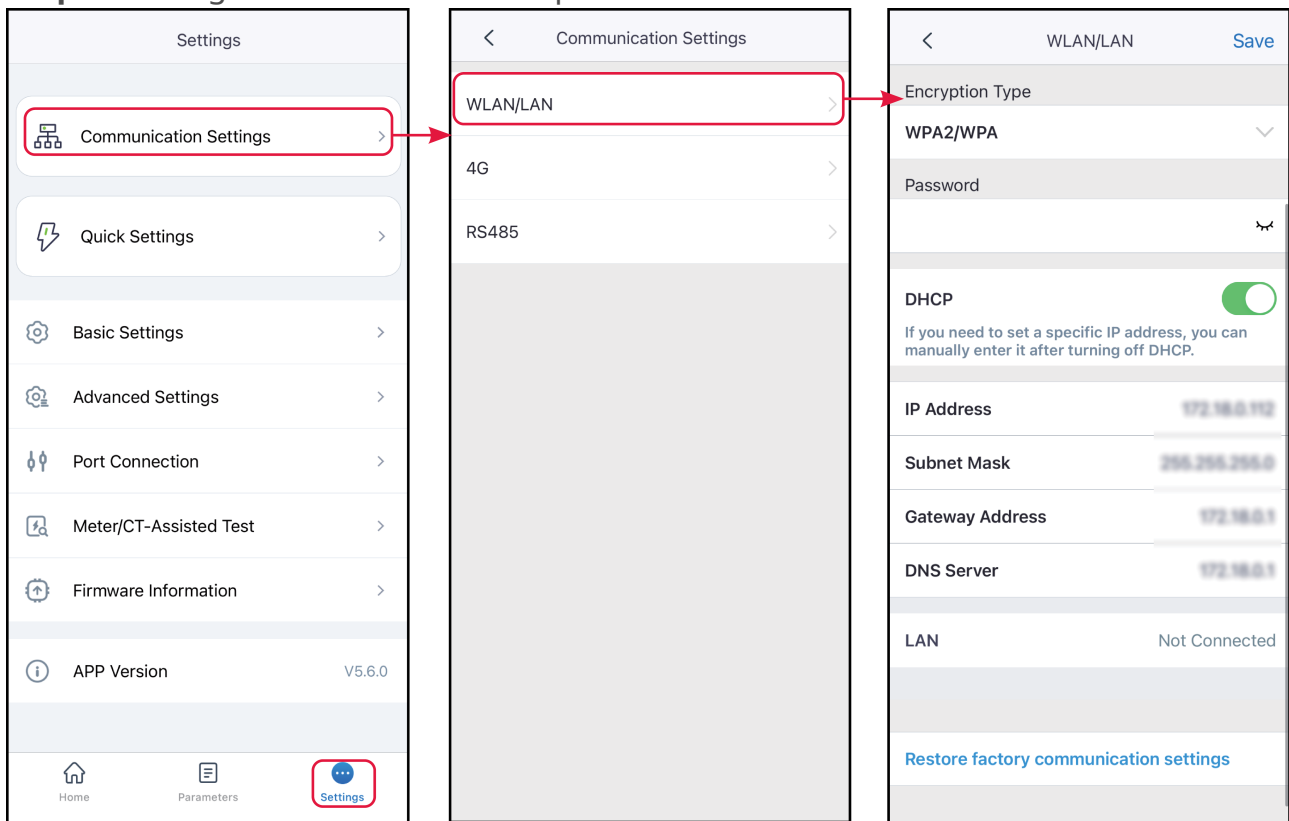

No.	Parameters	Description
1	Network Name	Only for WLAN. Select WiFi based on the actual connecting.
2	Password	Only for WLAN. WiFi password for the actual connected network.
3	DHCP	Enable DHCP when the router is in dynamic IP mode. Disable DHCP when a switch is used or the router is in static IP mode.

No.	Parameters	Description
4	IP Address	Do not configure the parameters when DHCP is enabled. Configure the parameters according to the router or switch information when DHCP is disabled.
5	Subnet Mask	
6	Gateway Address	
7	DNS Server	

### 8.3.3 Configuring APN Parameters

#### NOTICE

- Configure the SIM card information of 4G communication device.
- If the 4G module does not offer bluetooth signal, please configure the APN parameters through the Bluetooth module or WiFi module first to achieve 4G communication.

**Step 1:** Tap **Home > Settings > Communication Settings > 4G** to set the parameters.

**Step 2:** Set the region and operator based on actual needs.

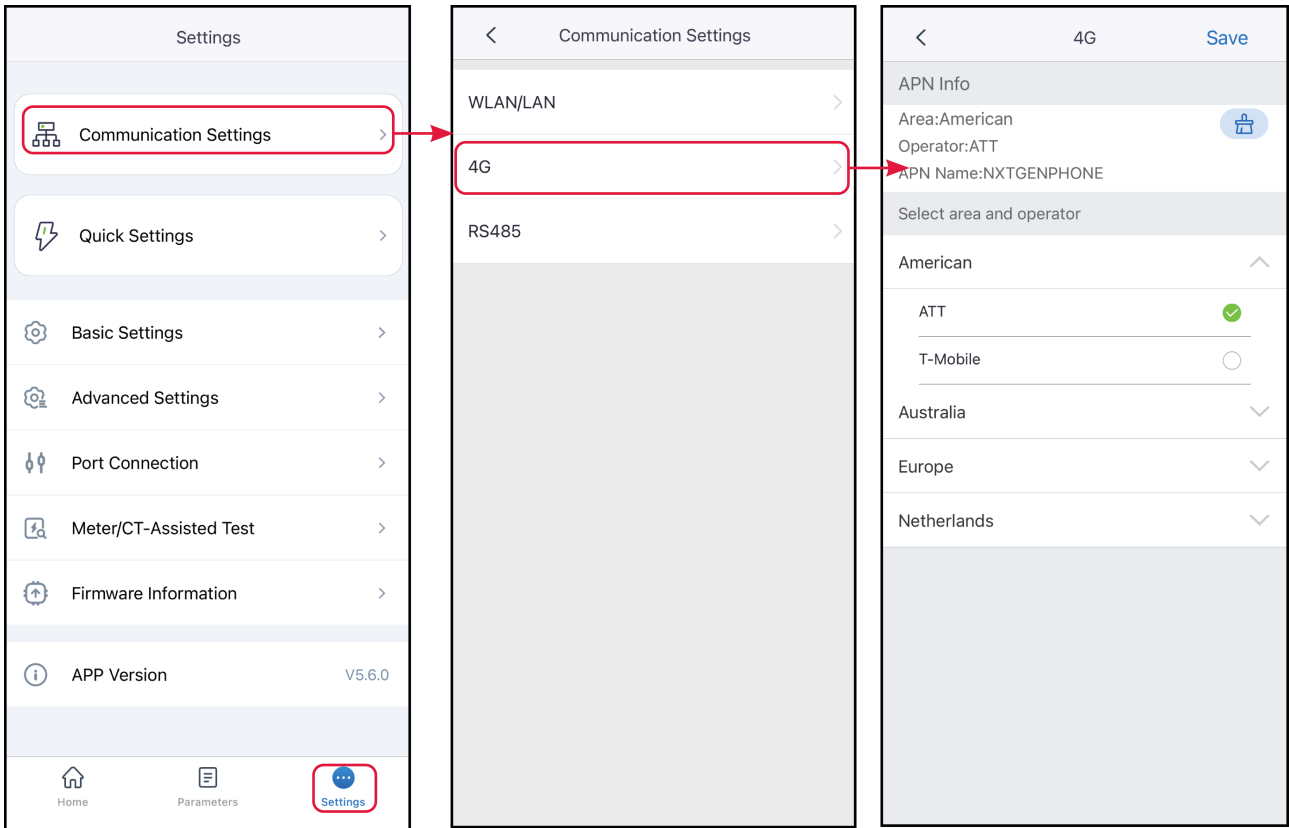

### 8.3.4 Configuring RS485 Parameters

#### NOTICE

Set the communication address of the inverter. For a single inverter, the address is set based on actual needs. For multi connected inverters, the address of each inverter should be different while cannot be 247.

**Step 1:** Tap **Home > Settings > Communication Settings > RS485** to set the parameters.

**Step 2 :** Set the Modbus Address And Baud Rate base on actual situation.

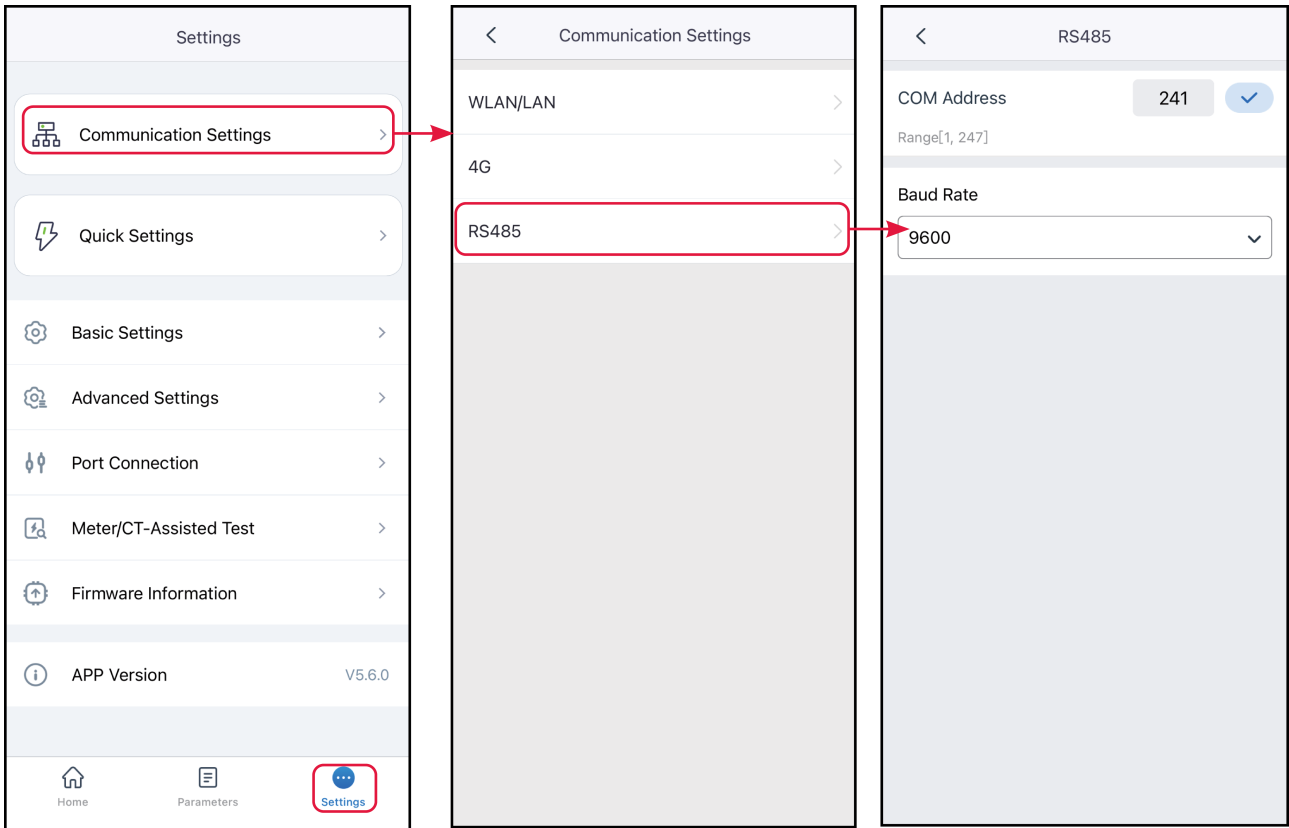

## 8.4 Quick Setting the Basic Information

## NOTICE

- The setting page varies depending on inverter model.
- The parameters will be configured automatically after selecting the safety country/region, including overvoltage protection, undervoltage protection, overfrequency protection, underfrequency protection, voltage/frequency connection protection,  $\cos\phi$  curve, Q(U) curve, P(U) curve, FP curve, HVRT, LVRT, etc. Tap Home > Settings > Advanced Settings > Safety Parameters to check the parameters after selecting the safety country.
- The power generation efficiency is different in different working modes. Set the working mode according to the local requirements and situation.
  - Self-use mode: The basic working mode of the system. PV power generation is used to supply power to the load first, the excess power is used to charge the battery, and the remaining power is sold to the grid. When PV power generation cannot meet the load's power demand, the battery will supply power to the load; when the battery power also cannot meet the load's power demand, the grid will supply power to the load.
  - Back-up mode: The back-up mode is mainly applied to the scenario where the grid is unstable. When the grid is disconnected, the inverter turns to off-grid mode and the battery will supply power to the load; when the grid is restored, the inverter switches to grid-tied mode.
  - Economic mode: It is recommended to use economic mode in scenarios when the peak-valley electricity price varies a lot. Select Economic mode only when it meets the local laws and regulations. Set the battery to charge mode during Vally period to charge battery with grid power. And set the battery to discharge mode during Peak period to power the load with the battery.
  - Off-grid mode: suitable for areas without power grid. PV and batteries form a pure off-grid system. PV generates electricity to power the load and excess electricity charges the battery. When PV power generation cannot meet the power demand of the load, the battery will supply power to the load.
  - Smart charging: In some countries/regions, the PV power feed into the utility grid is limited. Select Smart Charging to charge the battery using the surplus power to minimize PV power waste.
  - Peak shaving mode: Peak shaving mode is mainly applicable to peak power limited scenarios. When the total power consumption of the load exceeds the power consumption quota in a short period of time, battery discharge can be used to reduce the power exceeding the quota.

### 8.4.1 Quick Setting the Basic Information( Type III)

**Step 1:** Tap **Home > Settings > Quick Settings** to set the parameters.

**Step 2 :** Enter the password for quick settings. Contact the supplier or after sales service for password. Password for professional technicians only.

**Step 3:** Select safety country accordingly. Tap **Next** to set the Battery Connect Mode.

**Step 4 :** Select the actual mode in which the battery is connected to the inverter. The basic settings are completed if there is no battery connected in the system. Tap **Next** to set the Battery Model if there is any battery connected in the system.

**Step 5:** Select the actual battery model. Tap **Next** to set the Working Mode.

**Step 6:**Set the working mode based on actual needs. Tap **Next** to conduct System Self-Test.

- If Peakshaving mode is selected, tap Settings to set the parameters.

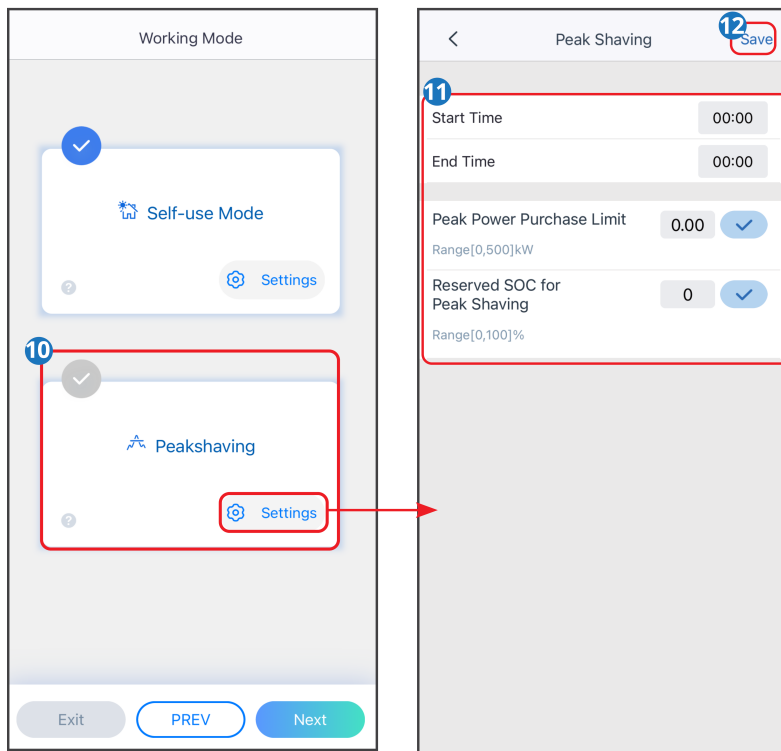

No.	Parameters	Description
Peakshaving		
1	Start Time	



No.	Parameters	Description
2	End Time	The utility grid will charge the battery between Start Time and End Time if the load power consumption do not exceed the power quota. Otherwise, only PV power can be used to charge the battery.
3	Peak Power Purchase Limit	Set the maximum power limit allowed to purchase from the grid. When the loads consume power exceed the sum of the power generated in the PV system and Peak Power Purchase Limit, the excess power will be made up by the battery.
4	Reserved SOC For Peakshaving	In Peak Shaving mode, the battery SOC should be lower than Reserved SOC For Peakshaving. Once the battery SOC is higher than Reserved SOC For Peakshaving, the peak shaving mode fails.

- When Self-Use Mode is selected, tap Settings to set the Depth Of Discharge(On-Grid)and Depth Of Discharge(Off-Grid). And tap Advanced Settings to set Back-Up Mode, TOU Mode or Smart Charging based on actual needs. If TOU Mode is selected, tap Add to set the working time and working mode of the battery group.

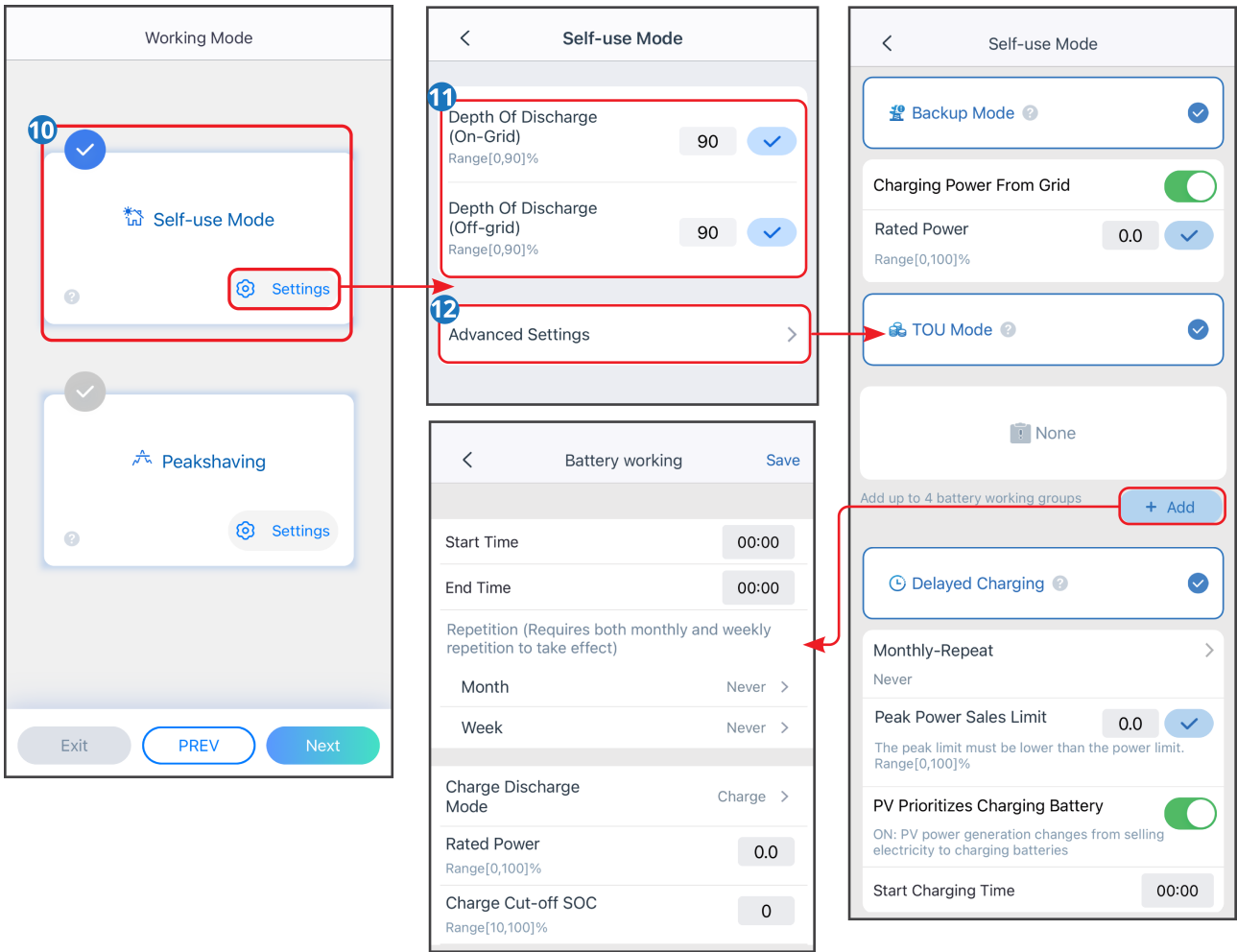

No.	Parameters	Description
Self-use mode		
1	Depth Of Discharge (On-Grid)	The maximum depth of discharge of the battery when the system is working on-grid.
2	Depth Of Discharge (Off-grid)	The maximum depth of discharge of the battery when the system is working off-grid.
Back-up mode		
3	Charging Power From Grid	Enable Charging Power From Grid to allow power purchasing from the utility grid.
4	Rated Power	The percentage of the purchasing power to the rated power of the inverter.

No.	Parameters	Description
TOU mode		
5	Start Time	Within the Start Time and End Time, the battery is charged or discharged according to the set Battery Mode as well as the Rated Power.
6	End Time	
7	Charge Discharge Mode	Charge or discharge according to actual needs.
8	Rated Power	The percentage of the charging/discharging power to the rated power of the inverter.
9	Charge Cut-off SOC	The battery stop charging/discharging once the battery SOC reaches Charge Cut-off SOC.
Smart charging		
10	Monthly-Repeat	Set the smart charging months. More than one month can be set.
11	Peak Power Sales Limit	Set the Peak Power Sales Limit in compliance with local laws and regulations. The Peak Limiting Power shall be lower than the output power limit specified by local requirements.
12	PV Prioritizes Charging Battery	During charging time, the PV power will first charge the battery.
13	Start Charging Time	

**Step 7:** Execute device self-check or skip it based on actual needs.

**Step 8 :** Tap **Recheck** or **Next** to complete the test based on your actual needs. Tap Export to export the test reports if needed.

**Step 9 :** Tap **Complete** to complete the quick settings.

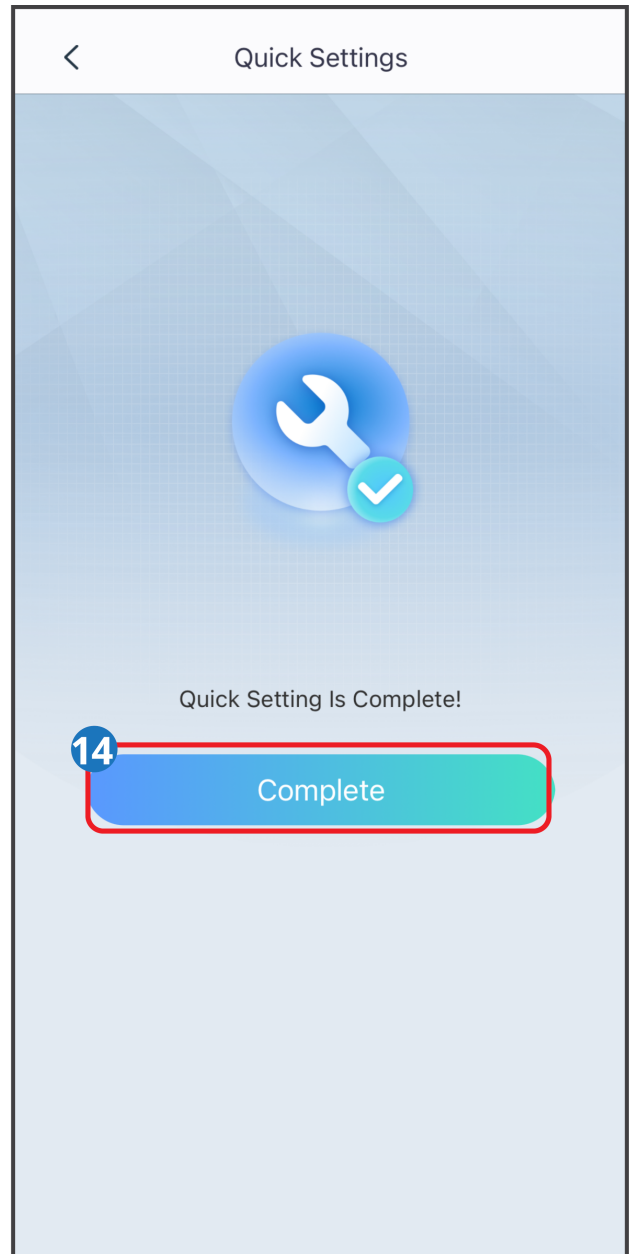
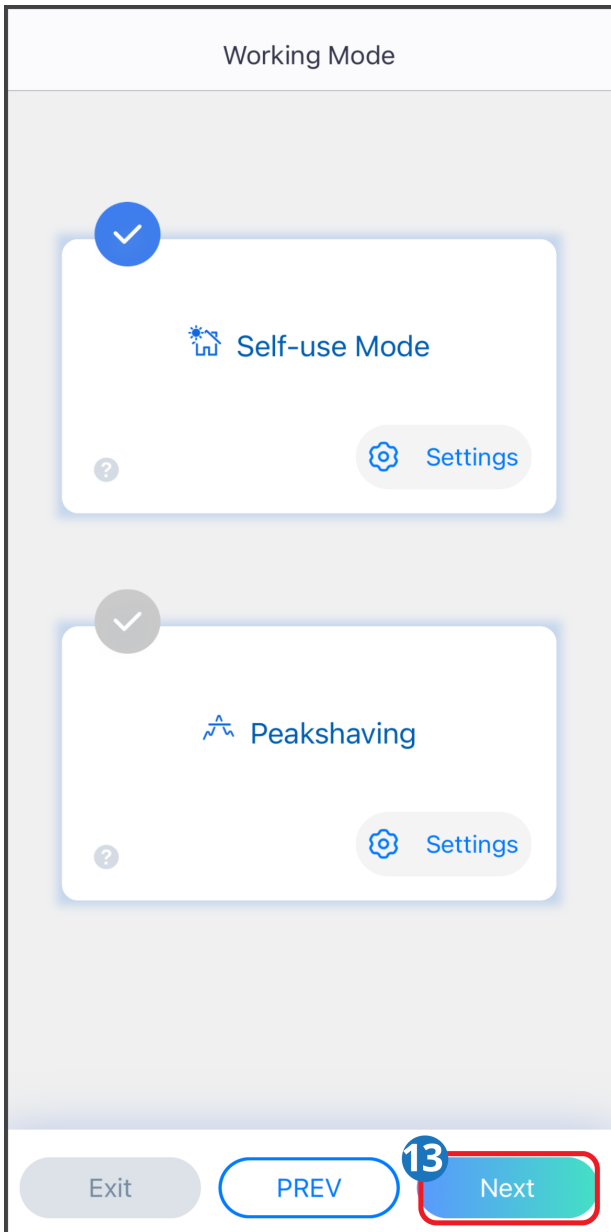

## 8.5 Creating a Station

**Step 1:** Tap  on overview or station page, or tap **Create Station** on service page.

**Step 2:** Enter station information on the **Creat Station** page.

**Step 3:** Tap **Save&Exit** to complete creating a station, without devices added. Or tap **Save&Continue** to add devices. Support adding multiple devices.

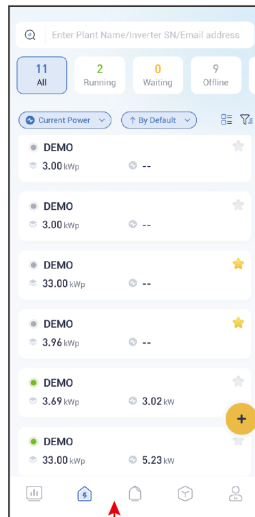
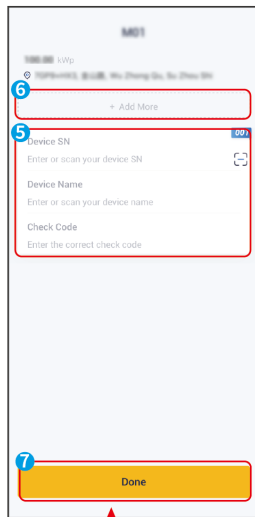
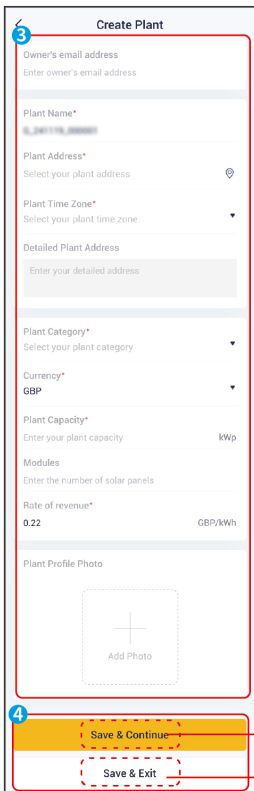
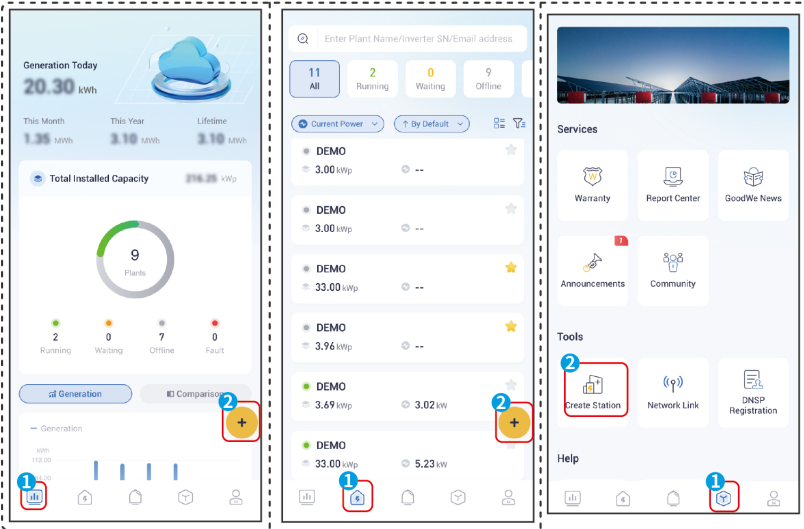

# 9 System Commissioning

## 9.1 Commissioning Method Overview

The inverter without LCD screen only supports setting the inverter through the SolarGo APP.

The inverter with LCD screen supports setting the inverter through LCD screen and the SolarGo APP.

## 9.2 Configuration via LCD

### 9.2.1 LCD Overview

With the LCD screen, the user can:







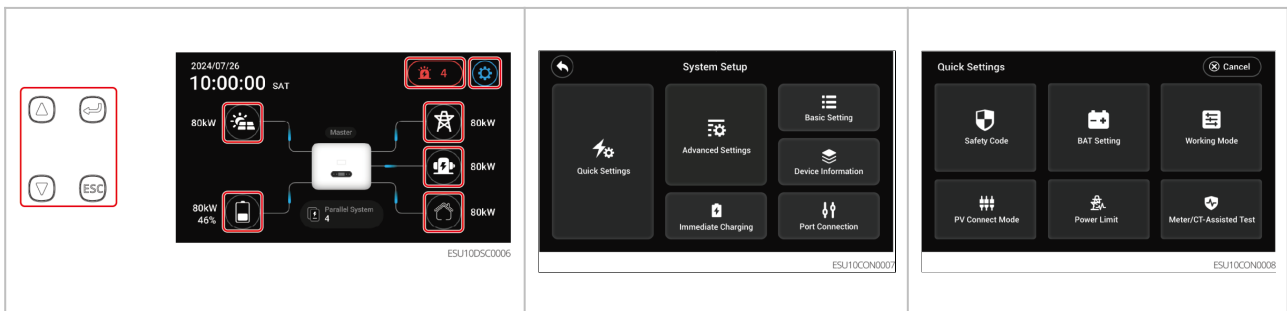



1. Check the operating data, software version, alarms, etc.
2. Set parameters, safety regions, power limit, etc.

### Introduction of LCD interface

LCD supports both touch and keys.



Name/Icon	Description
	Up button.
	Down button.
	Enter button.

Name/Icon	Description
	<ul style="list-style-type: none"> <li>• Short press: Exit button.</li> <li>•  Long press 5 seconds: Restart the device</li> </ul>
	Used to view information such as PV current, voltage, and power generation.
	Used to view information such as battery model and status.
	Used to view the alarm and fault information of the inverter.
	Used to enter the settings interface of the inverter.
	Used to view the status of the power grid and information.
	Used to check the status of the generator.
	Used to view the load information of the inverter.
	Return to the main screen.
<b>Cancel</b>	Return to previous menu.
<b>Next</b>	Go to the next setting page.
<b>Back</b>	Return to the previous setting page.

## LCD setting interface structure

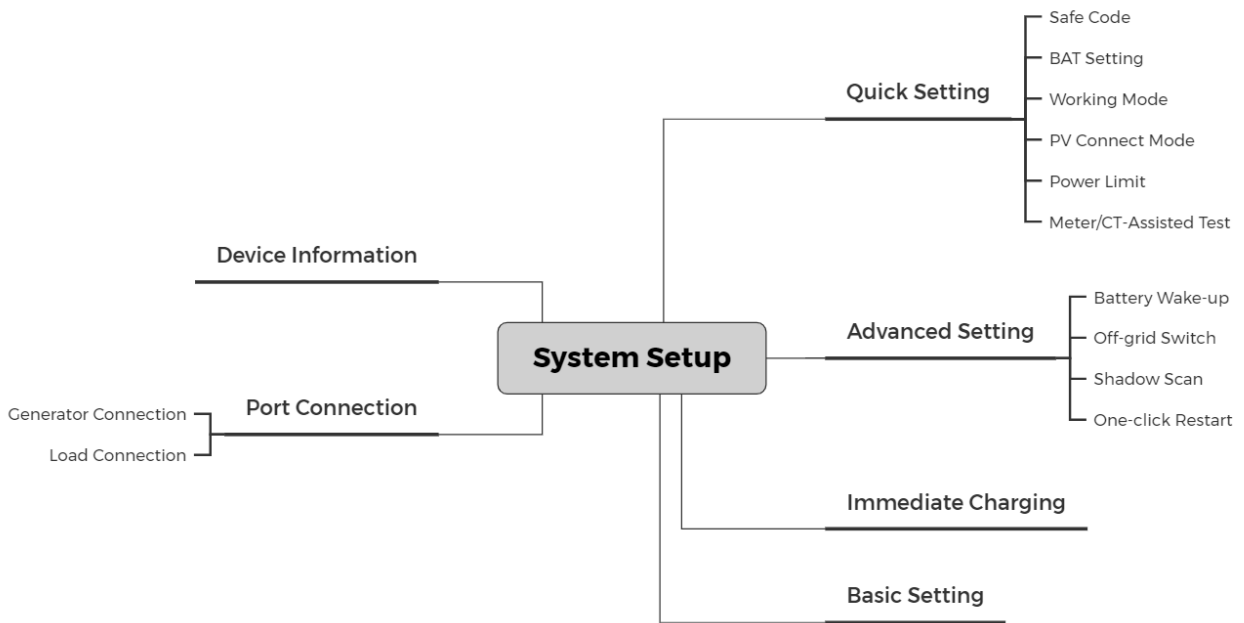

## 9.2.2 Quick Settings

Setting safety code

1. Tap Home > Quick Settings > Safe Code to set the parameters.
2. Set the parameters based on actual needs.
3. After the setting is completed, please click Confirm. After the interface prompts Confirm OK, the parameters are set successfully.

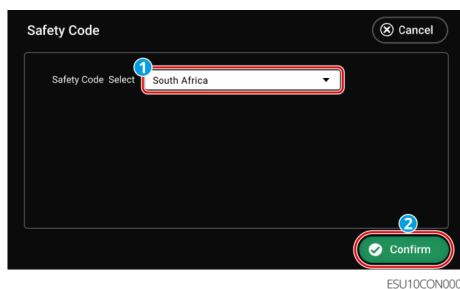

Parameter	Safety Code	Description
Safety Code select	South Africa	Select the corresponding safety code based on the country or region where the equipment is located.
	Pakistan	
	Argentina	
	Philippines	



	60Hz Default	
	60Hz Default	
	50Hz Default	

### Set parameters for lithium battery

1. Tap Home > Quick Settings > BAT Setting to enter parameter setting interface.
2. Set the parameters based on actual needs.
3. After the setting is completed, please click Confirm. After the interface prompts Confirm OK, the parameters are set successfully.

NOTICE

Please make sure that you click Confirm on each page to ensure that the parameters take effect, otherwise the system will run with default parameters.

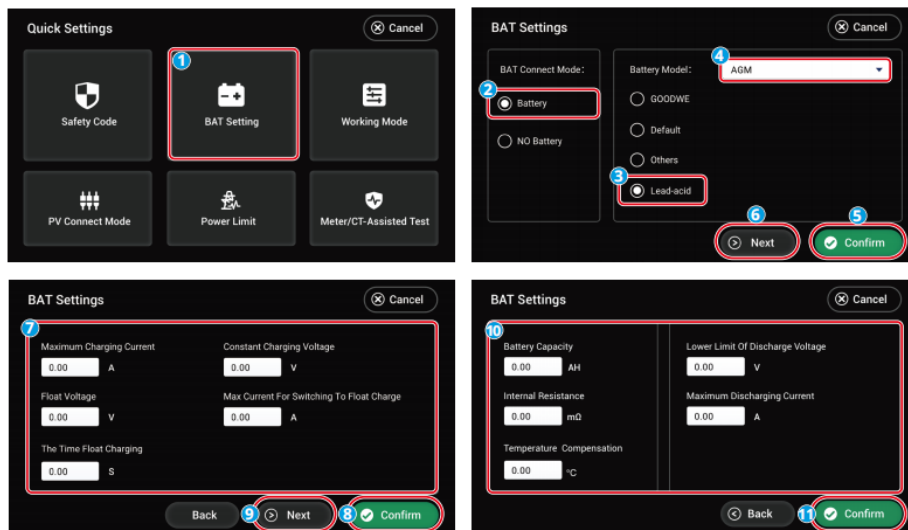

ESU1000V0009

### Setting Basic Parameter

BAT Connection Mode	Type	Description
Battery	GOODWE	If the system is connected to a GOODWE brand lithium battery, please select GOODWE and choose the correct model.

	Default	If the third-party lithium battery model connected in the system is not in this list, please select it according to the actual situation:  <ul style="list-style-type: none"> <li>• Lithium 50Ah</li> <li>• Lithium 100Ah</li> </ul>
	Others	If the third-party lithium battery model connected to the system is in this list, please select the correct model according to the actual situation.
	Lead acid	If a lead-acid battery is connected to the system, select Lead acid and choose the correct type of lead-acid. Only supports: GEL, AGM, Flooded.
NO Battery	There is no battery connected in the system.	
BAT Setting	Set according to the actual connected battery in the system.	

#### Set parameters for lithium battery

Parameter	Description
SOC Protection	Enable or disable SOC protection.
Depth Of Discharge (On-Grid)	The maximum depth of discharge of the battery when the system is working on-grid.
Depth Of Discharge (Off-Grid)	The maximum depth of discharge of the battery when the system is working off-grid.
Backup SOC Holding	The battery will be charged to preset SOC protection value by utility grid or PV when the system is running on-grid, so that the battery SOC is sufficient to maintain normal working when the system is off-grid.

#### Set parameters for lead-acid battery

Parameter	Description
Maximum Charging Current	

Constant Voltage	Charging	The battery charging mode is set to constant voltage charging by default. The maximum charging voltage and current in the constant charge state. Please set them according to the battery technical parameters.
Float Voltage		The battery charging current is less than Maximum Current For Switch To Float Charge and the duration reaches The Time Float Charging, the battery charging status changes from Constant Charge mode to Float Charge mode. When the battery is approaching full charge, it will switch to float charging mode. This value is the upper limit of charging voltage in this mode. Please set it according to the battery technical parameters.
The Time Float Charging		
Maximum Current For Switch To Float Charge		
Battery Capacity		Please set it according to the battery technical parameter.
Internal Resistance		The internal resistance of the battery. Please set it according to the battery technical parameters.
Temperature Compensation		By default, when the temperature is higher than 25°C, the upper limit of charging voltage will decrease by 3mV for every 1°C increase. The actual settings should be based on the technical parameter of the battery.
Lower Limit Of Discharge Voltage		Please set it according to the battery technical parameters.
Maximum Discharging Current		Please set it according to the battery technical parameters. The greater the discharge current is, the shorter the working time of the battery is.

### Setting Working Mode

1. Tap Home  > Quick Settings > Working Mode to set the parameters.
2. Set the parameters based on actual needs.
3. After the setting is completed, please click Confirm. After the interface prompts Confirm OK, the parameters are set successfully.

**NOTICE**

Please make sure that you click Confirm on each page to ensure that the parameters take effect, otherwise the system will run with default parameters.

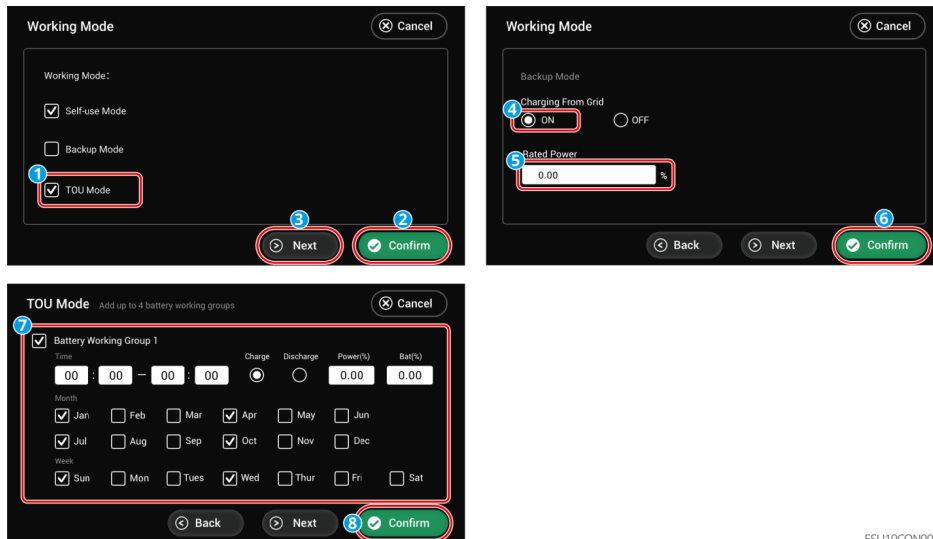

ESU10CON0014

Parameter		Description
Self-use Mode		Based on Self-use Mode, Back-up Mode and TOU Mode can be enabled at the same time, and the inverter will automatically select the working mode. Operation priority: Back-up Mode>TOU Mode >Self-use Mode.
Back-up Mode	Charging From Grid	Enabling this function allows the system to purchase electricity from power grid.
	Rated Power	The percentage of power purchased compare to the rated power of the inverter.
TOU Mode	Time	Within the start and end time, the battery will charge or discharge based on the set charge-discharge mode and rated power.
	Charge/Discharge	Set to charge or discharge based on actual needs.
	Power (%)	The percentage of power during charging or discharging compared to the rated power of the inverter.

	Bat (%)	<p>The battery stop charging once the battery SOC reaches Charge Cut-off SOC.</p> <p>To set the SOC for stopping the battery discharge, please refer to <a href="#">section 9.2.2.2 on setting battery parameters</a> and set the Depth of Discharge (On Grid) and Depth of Discharge (Off Grid) through the LCD screen.</p>
--	---------	--

### Setting PV Connect Mode

1. Tap Home  > Quick Settings > PV Connect Mode to set the parameters.
2. Set the parameters based on actual needs.
3. After the setting is completed, please click Confirm. After the interface prompts Confirm OK, the parameters are set successfully.

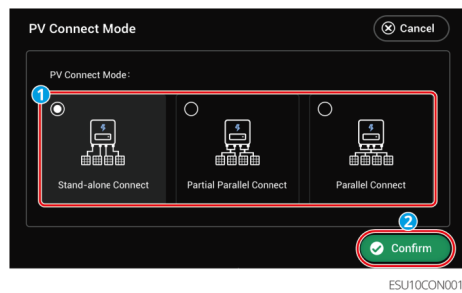

Parameter	Description
Stand-alone Connect	The PV strings are connected to the MPPT terminals one by one.
Partial Parallel Connect	The PV strings are connected to the inverter in both stand-alone and parallel connection. For example, one PV string connect to MPPT1 and MPPT2, another PV string connect to MPPT3.
Parallel Connect	When the external PV string is connected to the inverter side PV input port, the same PV string is connected to multiple PV input ports.

### Setting the on-grid power limit

1. Tap Home  > Quick Settings > Power Limit the parameters.
2. Set the parameters based on actual needs.
3. After the setting is completed, please click Confirm. After the interface prompts

Confirm OK, the parameters are set successfully.

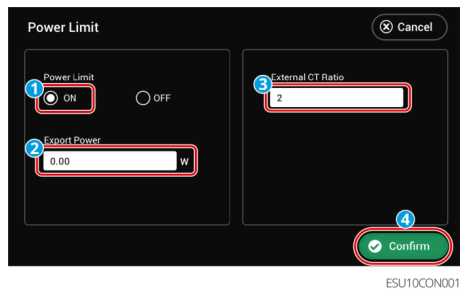

Parameter	Description
Power Limit	Enable Power Limit when power limiting is required by local grid standards and requirements.
Export Power	Set the value based on the actual maximum power feed into the utility grid.
External CT Ratio	<p>Set the ratio of the primary current to the secondary current of the external CT.</p> <ul style="list-style-type: none"> <li>Built in electric meter or GMK110: No need to set CT ratio. The default CT ratio is 120A/40mA.</li> <li>GM330: Supports purchasing from GOODWE or third-party, CT ratio requirement: nA/5A</li> <li>nA: For the primary input current of CT, n ranges from 200 to -5000.</li> <li>5A: CT secondary input current of CT.</li> </ul>

### Meter/CT Assisted Test

1. Through the main interface, click  > Quick Settings > Meter/ CT Assisted Test to enter the parameter setting interface.
2. Click Start Test to begin the test. After the test is completed, judge the test result according to the interface prompts.

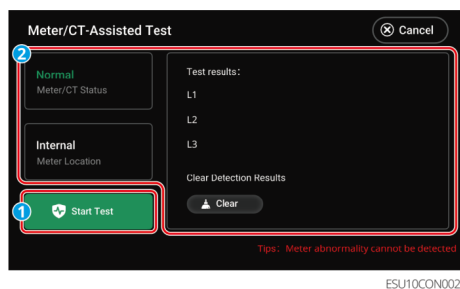

### 9.2.3 Setting Advanced Parameters

1. Tap Home  > Advanced Settings to set the parameters. Enter the initial password: 1111.
2. Set the parameters based on actual needs.
3. After the setting is completed, please click Confirm. After the interface prompts Confirm OK, the parameters are set successfully.

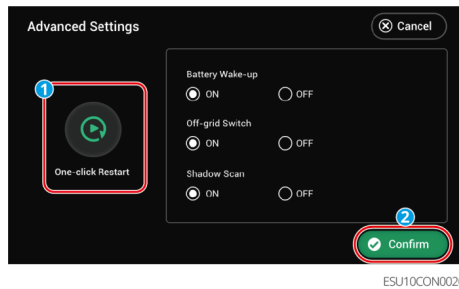

Parameter	Description
One-click restart	By using this function, the inverter can be quickly restarted.
Battery Wake-up	After being turned on, the battery can be awakened when it shuts down due to undervoltage protection. Only applicable to lithium batteries without circuit breakers. After being turned on, the output voltage of the battery port is about 60V.
Off-grid Switch	In off-grid mode, the switch controls the on/off of the inverter's off-grid function. In on-grid mode, this function does not take effect. The switch is initially in the ON state, and the off-grid function is enabled. After the inverter is powered on, the off-grid output function of the inverter is enabled. In the off-grid state, turning off and then turning on the off-grid switch, the off-grid overload time can be known and the off-grid output can be restarted.
Shadow Scan	Enable Shadow Scan when the PV panels are severely shadowed to optimize the power generation efficiency.

### 9.2.4 Setting Immediate Charging

1. Tap Home  > Immediate Charging to set the parameters.

2. Set the parameters based on actual needs.
3. After the setting is completed, please click Confirm. After the interface prompts Confirm OK, the parameters are set successfully.

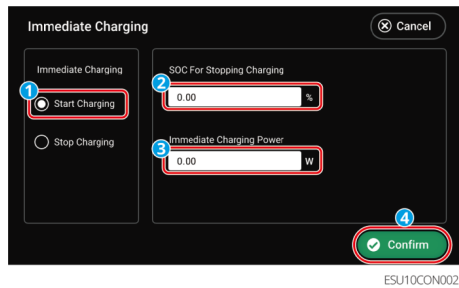

Parameter	Description
Immediate Charging	Enable to charge the battery by the grid immediately. This takes effect once. Enable or Disable based on actual needs.
SOC For Stopping Charging	Stop charging the battery once the battery SOC reaches SOC For Stopping Charging.
Immediate Charging Power	Indicates the percentage of the charging power to the inverter rated power when enabling Immediate Charging. For example, setting the Immediate Charging Power of a 10kW inverter to 60, which means the charging power of the inverter is $10\text{kW} \times 60\% = 6\text{kW}$ .

## 9.2.5 Setting the Basic Information

1. Tap Home  > Basic Settings to set the parameters.
2. Set the parameters based on actual needs.
3. After the setting is completed, please click Confirm. After the interface prompts Confirm OK, the parameters are set successfully.

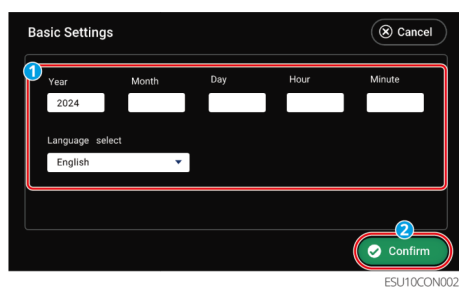



## 9.2.6 Viewing Device Information

1. Tap Home  > Device Information to search the parameters.

**NOTICE**

Inverter serial number, DSP, BMS, LCD and ARM can be queried.

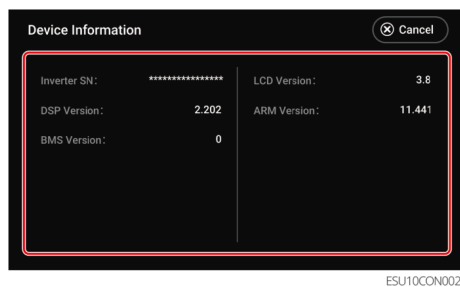

## 9.2.7 Setting Port Connection

Setting Port Connection Generators

1. After connecting to the SolarGo APP, go to Home  > Port Connection, entering the parameter setting interface.
2. Set the parameters based on actual needs.
3. After the setting is completed, please click Confirm. After the interface prompts Confirm OK, the parameters are set successfully.

**NOTICE**

Please make sure that you click Confirm on each page to ensure that the parameters take effect, otherwise the system will run with default parameters.

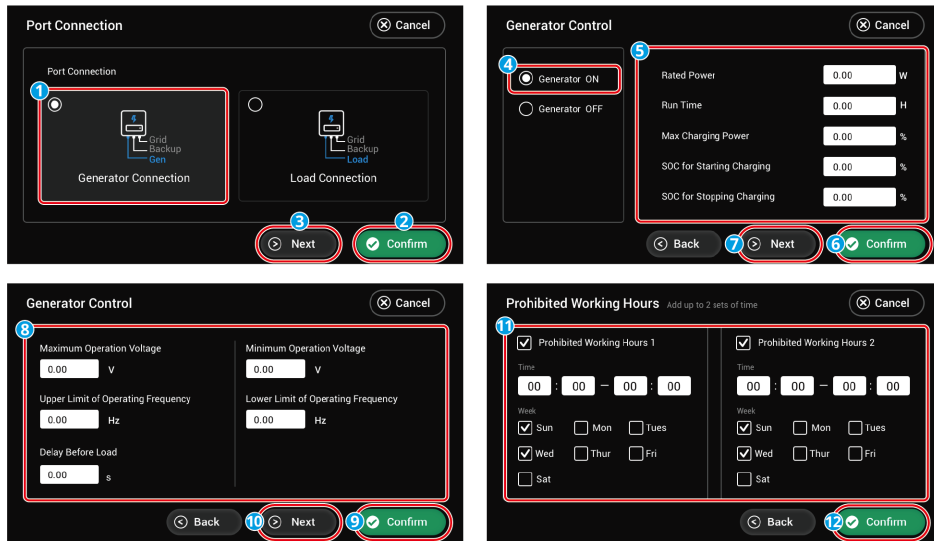

ESU10CON0022

No.	Parameter	Description
1	Generator ON/OFF	Controls the start and stop of the generator. Only applicable to generators that support dry contact.
2	Rated Power	Rated power of the generator.
3	Run Time	The duration of continuous operation of a generator. When the working time exceeds the set value, the generator will automatically shut down. This feature only applies to generators that support dry contact connection.
4	Max Charging Power	Set the maximum charge power for the generator battery.
5	SOC for Starting Charging	Set the starting SOC for the generator to charge the battery. When the SOC of the battery is lower than the set value, the generator will charge the battery.
6	SOC For Stopping Charging	Set the stopping SOC for the generator stopping charging the battery. When the SOC of the battery reaches the set value, the generator will stop charging the battery.
7	Maximum Operation Voltage	Set the upper limit of operating voltage for the generator.
8	Minimum Operation Voltage	Set the lower limit of operating voltage for the generator.
9	Upper Limit Of Operating Frequency	Set the upper limit of operating frequency for the generator.

10	Lower Limit Of Operating Frequency	Set the lower limit of operating frequency for the generator.
11	Delay Before Load	The no-load preheating time before the generator is loaded.
12	Prohibited Working Hours	Please set the generator prohibition time according to the actual situation.

## Setting Port Connection Load Control

### Dry Contact Mode

1. After connecting to the SolarGo APP, go to Home  > Port Connection, entering the parameter setting interface.
2. Set the parameters based on actual needs.
3. After the setting is completed, please click Confirm. After the interface prompts Confirm OK, the parameters are set successfully.

### NOTICE

Please make sure that you click Confirm on each page to ensure that the parameters take effect, otherwise the system will run with default parameters.

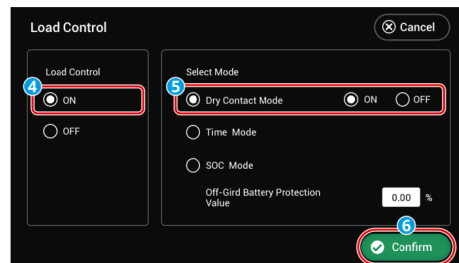
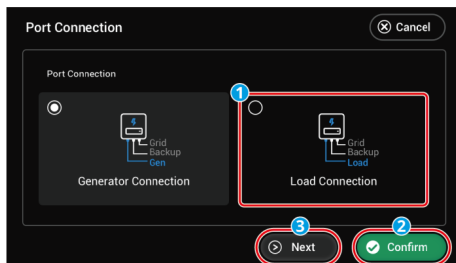

ESU10CON0023

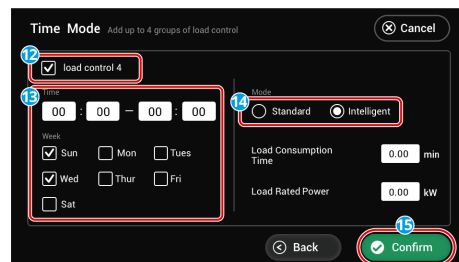
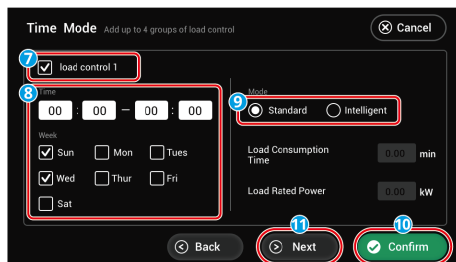
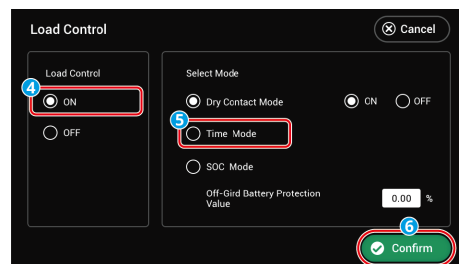
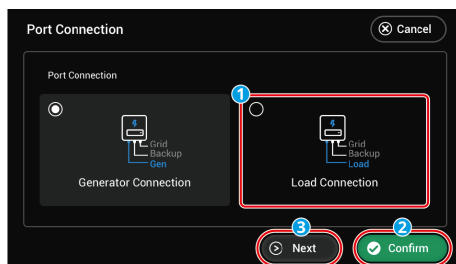

ESU10CON0025

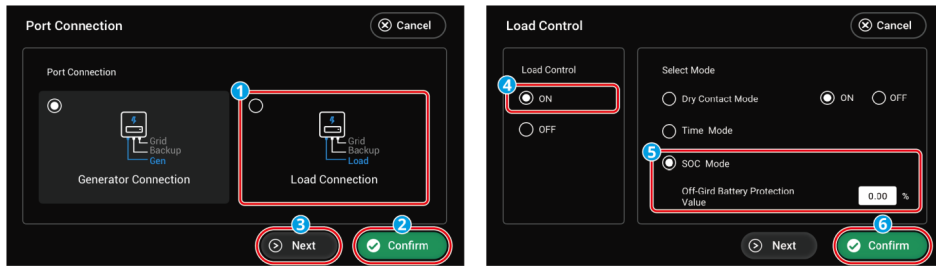

ESU10CON0024

No.	Parameter	Description
1	Load Control ON/OFF	Set the load control function on/off.
2	Dry Contact Mode	ON: When the switch is ON, the loads will be powered. OFF: When the switch is OFF, the power will be cut off.
3	Time Mode	Set the time to enable the load, and the load will be powered automatically within the setting time period. Standard mode or intelligent mode can be selected.
4	Load Control 1	Set the 1st group of load control time, and a total of 4 groups can be set.
5	Mode: Standard/Intelligent	Standard: The loads will be powered within the setting time period. Intelligent: When the residual energy generated by the PV exceeds the preset load power rating within a set time period, it starts to supply power to the load.
6	Load Consumption Time	Minimum time of operation after the load is turned on to avoid frequent switching of the load due to energy fluctuations. Only applicable to intelligent mode.
7	Load Rated Power	When the residual energy generated by the PV exceeds the rated power of this load, it begins to power the load. Only applicable to intelligent mode.
8	SOC Mode	The inverter has an integrated relay controlling port, which can control whether to power the loads or not.

9	Off-Grid Battery Protection Value	In off-grid mode, the load connected to the port will not be powered if the BACKUP overload is detected or the battery SOC value is lower than the Off-grid battery protection value. Please set off-grid battery protection values based on actual needs.
---	-----------------------------------	--

## 9.3 Configuration via SolarGo APP

### 9.3.1 Product Introduction

#### NOTICE

- All the user interface (UI) screenshots or words in this document are based on **SolarGo app V6.6.0**. The UI may be different due to the version upgrade. The screenshots, words or data are for reference only.
- The method to set parameters is the same for all inverters. But the parameters displayed varies based on the equipment model and safety code. Refer to the actual interface display for specific parameters.
- Before setting any parameters, read through user manual of the App and the inverter or charger to learn the product functions and features. When the inverter parameters are set improperly, the inverter may fail to connect to the utility grid or fail to connect to the utility grid in compliance with related requirements and damage the battery, which will affect the inverter's power generation.

SolarGo App is a mobile application that communicates with the inverter via Bluetooth, WiFi, 4G, or GPRS. Commonly used functions are as follows:

- Check the operating data, software version, alarms of the inverter, etc.
- Set grid parameters and communication parameters of the inverter.
- Set charging mode of the charger.
- Maintain the equipment.

#### 9.3.1.1 Downloading and Installing the App

Make sure that the mobile phone meets the following requirements:

- Mobile phone operating system: Android 5.0 or later, iOS 13.0 or later.
- The mobile phone can access the Internet.
- The mobile phone supports WLAN or Bluetooth.

<b>NOTICE</b>
After installing the app, it can automatically prompt users to update the app version.

Method 1: Search SolarGo in Google Play (Android) or App Store (iOS) to download and install the app.

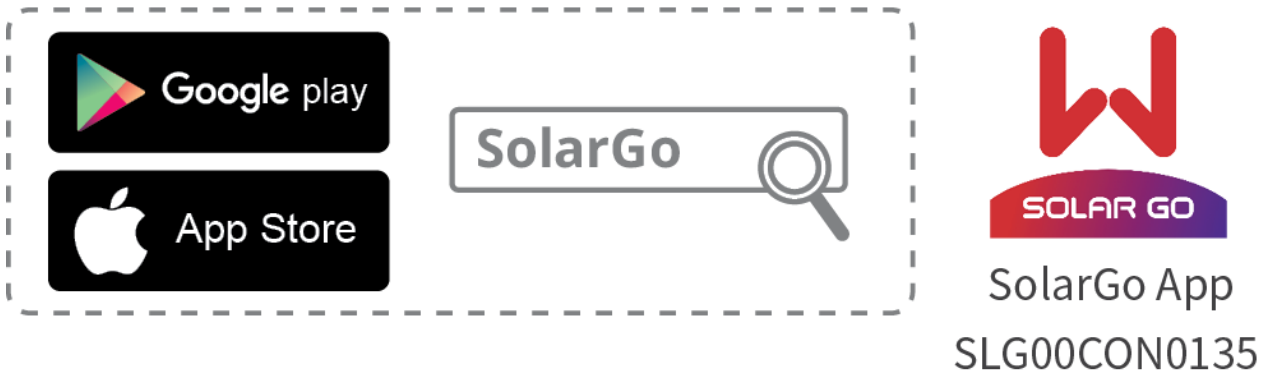

Method 2: Scan the QR code below to download and install the app.

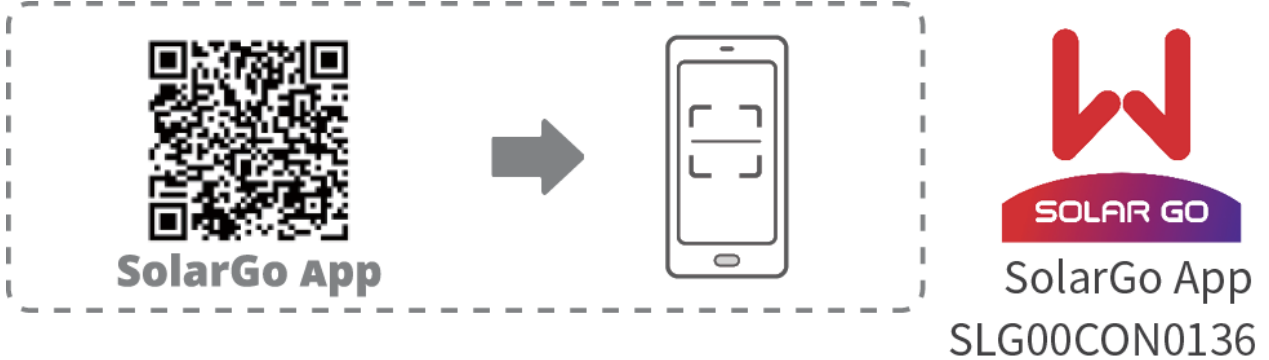

### 9.3.1.2 App Connection

Connect as the following shows after powering on the equipment.

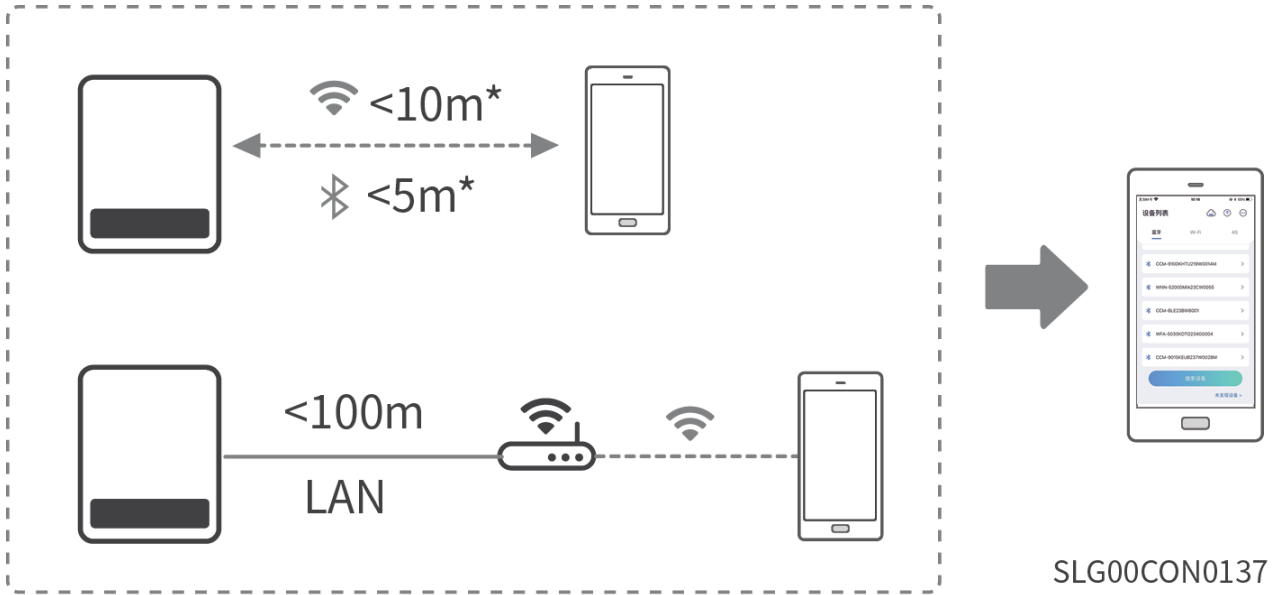

<b>NOTICE</b>
The connection distance varies depending on smart dongles. Refer to the actual used smart dongles.

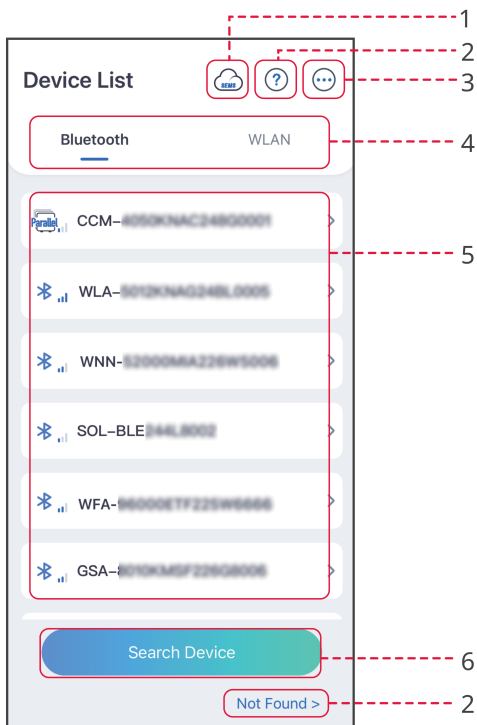

### 9.3.1.3 GUI Introductions to Login Page



No.	Name/Icon	Description
1		Tap the icon to open the page downloading the SEMS Portal app.

No.	Name/Icon	Description
2		Tap to read the connection guide.
	Not found	
3		<ul style="list-style-type: none"> <li>• Check information such as app version, local contacts, etc.</li> <li>• Other settings, such as update date, switch language, set temperature unit, etc.</li> </ul>
4	Bluetooth/WiFi/4G	Select based on actual communication method. If you have any problems, tap  or <b>NOT Found</b> to read the connection guides.
5	Device List	<ul style="list-style-type: none"> <li>• The list of all devices. The last digits of the device name are normally the serial number of the device.</li> <li>• Select the device by checking the serial number of the master inverter when multi inverters are parallel connected.</li> <li>• The device name varies depending on the inverter model or smart dongle model: <ul style="list-style-type: none"> <li>◦ Wi-Fi/LAN Kit, Wi-Fi Kit, Wi-Fi Box: Solar-WiFi***</li> <li>◦ External or integrated bluetooth module: Solar-BLE***</li> <li>◦ WiFi/LAN Kit-20: WLA-***</li> <li>◦ WiFi Kit-20: WFA-***</li> <li>◦ Ezlink3000: CCM-BLE***; CCM-***; ***</li> <li>◦ 4G Kit-CN-G20/4G Kit-CN-G21: GSA-***; GSB-***</li> <li>◦ 4G Kit-G20: GSC-***</li> <li>◦ Micro inverter: WNN***</li> <li>◦ AC Charger: ***</li> </ul> </li> </ul>
6	Search Device	Tap <b>Search Device</b> if the device is not found.



## 9.3.2 Connecting the Hybrid Inverter

### 9.3.2.1 Connecting the Hybrid Inverter (Bluetooth)

**Step 1** Ensure that the inverter is power on, both the inverter and the communication module are working properly.

**Step 2** Select **Bluetooth** tab on the SolarGo app homepage.

**Step 3** Pull down or tap **Search Device** to refresh the device list. Find the device by the the inverter serial number. Tap the device name to log into the **Home** page. Select the device by checking the serial number of the master inverter when multi inverters are parallel connected.

**Step 4** For first connection with the equipment via Bluetooth, there will be a Bluetooth pairing prompt, tap **Pair** to continue the connection.

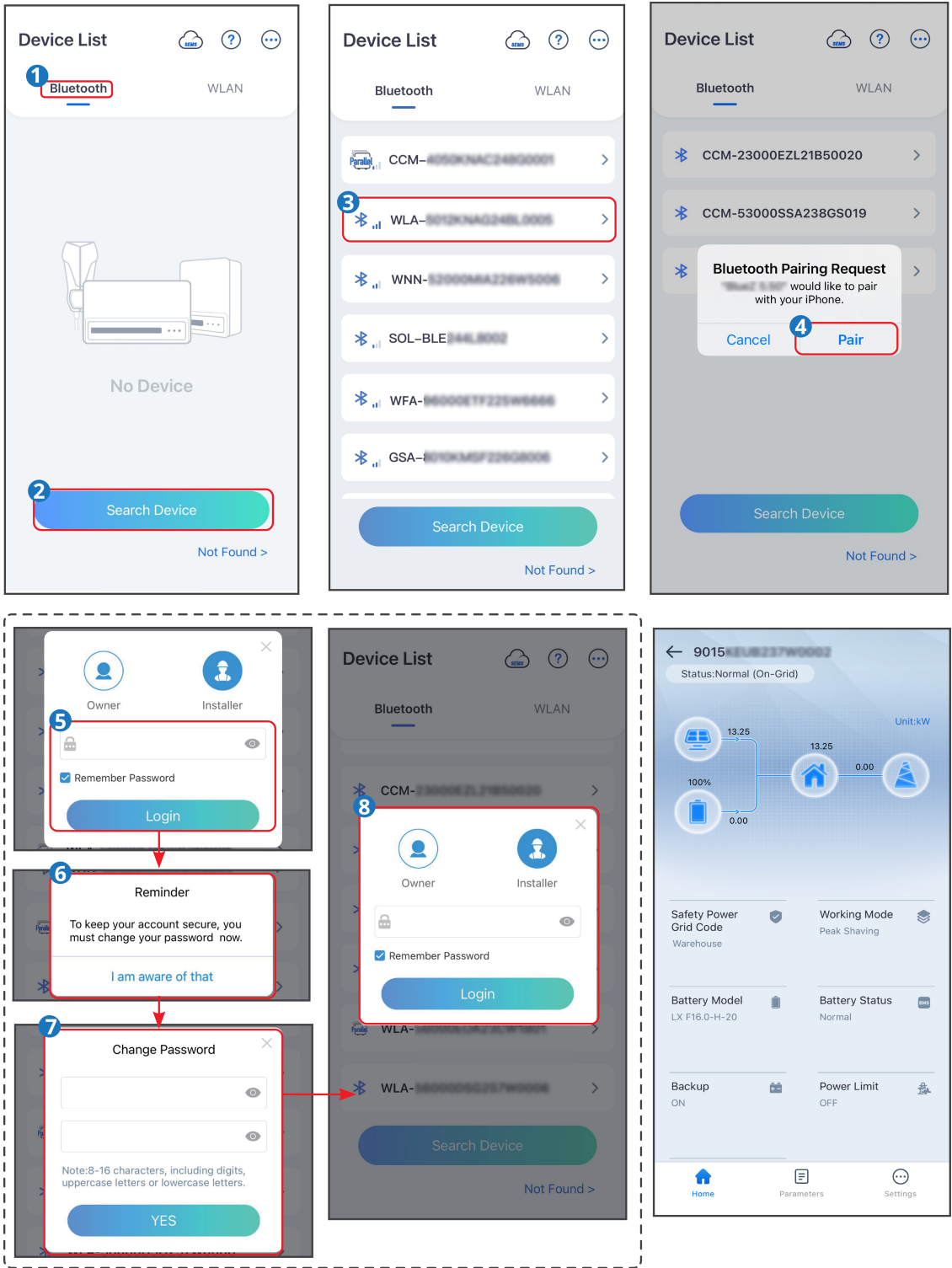

**Step 5** Log in as an Owner or an Installer. Initial password: 1234. Default password: 1234.

**Step 6** (Optional): If connecting via WLA-\*\*\* or WFA-\*\*\*, enable Bluetooth Stays On following the prompts as entering the device details page. Otherwise, the bluetooth signal of the device will be off after disconnection.

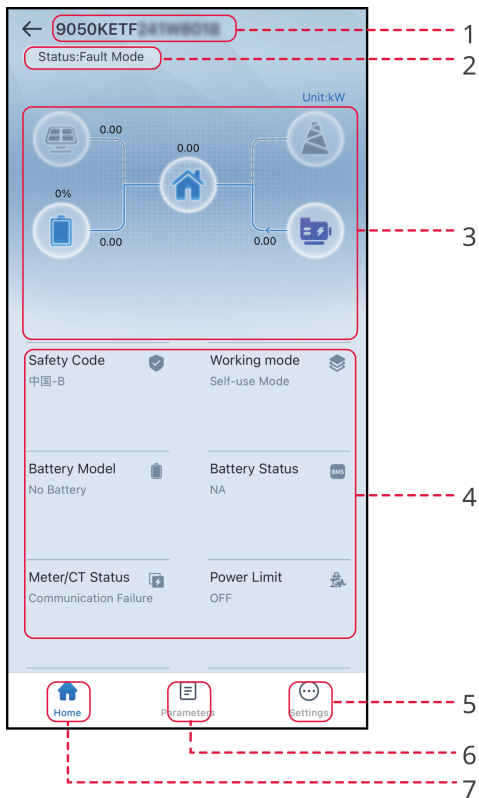

### 9.3.3 GUI Introductions to Hybrid Inverters



No.	Name/Icon	Description
1	Serial Number	Serial number of the connected inverter.
2	Device Status	Indicates the status of the inverter, such as Working, Fault, etc.
3	Energy Flow Chart	Indicates the energy flow chart of the PV system. The actual page prevails.
4	System Status	Indicates the system status, such as Safety Code, Working Mode, Battery Model, Battery Status, Power Limit, Three-Phase Unbalanced Output, etc..
5		Home. Tap Home to check Serial Number, Device Status, Energy Flow Chart, System Status, etc.
6		Parameters. Tap Parameters to check the inverter Data.

No.	Name/Icon	Description
7		<ul style="list-style-type: none"> <li>• Settings Tap to perform quick settings, basic settings, advanced settings, etc. on the inverter.</li> <li>• Login required to access Quick Setup and Advanced Setup interfaces Initial password: goodwe2010 or 1111.</li> </ul>

### 9.3.4 Setting Communication Parameters

#### NOTICE

The communication configuration interface may be different if the inverter uses different communication modes or connects different communication modules. Please refer to the actual interface.

#### 9.3.4.1 Setting Privacy and Security Parameters

##### Type I

**Step 1** : Tap **Home** > **Settings** > **Communication Setting** > **Privacy & Security** to set the parameters.

**Step 2** : Set the new password for the WiFi hotspot of the communication module, and tap **Save**.

**Step 3** Open the WiFi settings of your phone and connect to the inverter's WiFi signal (Solar WiFi\*\*) with the new password.

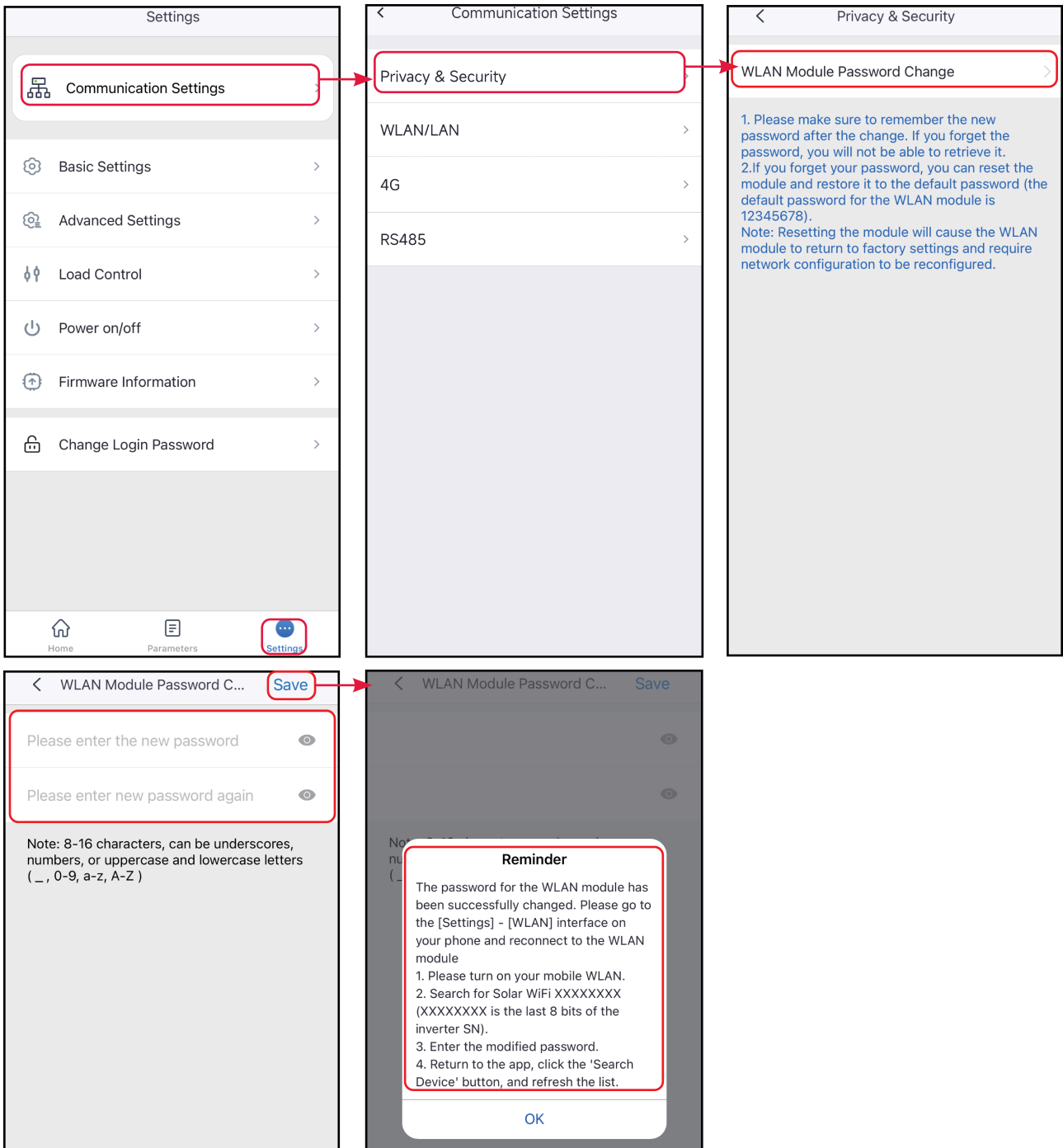

## Type II

**Step 1 :** Tap **Home > Settings > Communication Setting > Privacy & Security** to set the parameters.

**Step 2** Enable Bluetooth Stays On or WLAN Control based on actual needs.

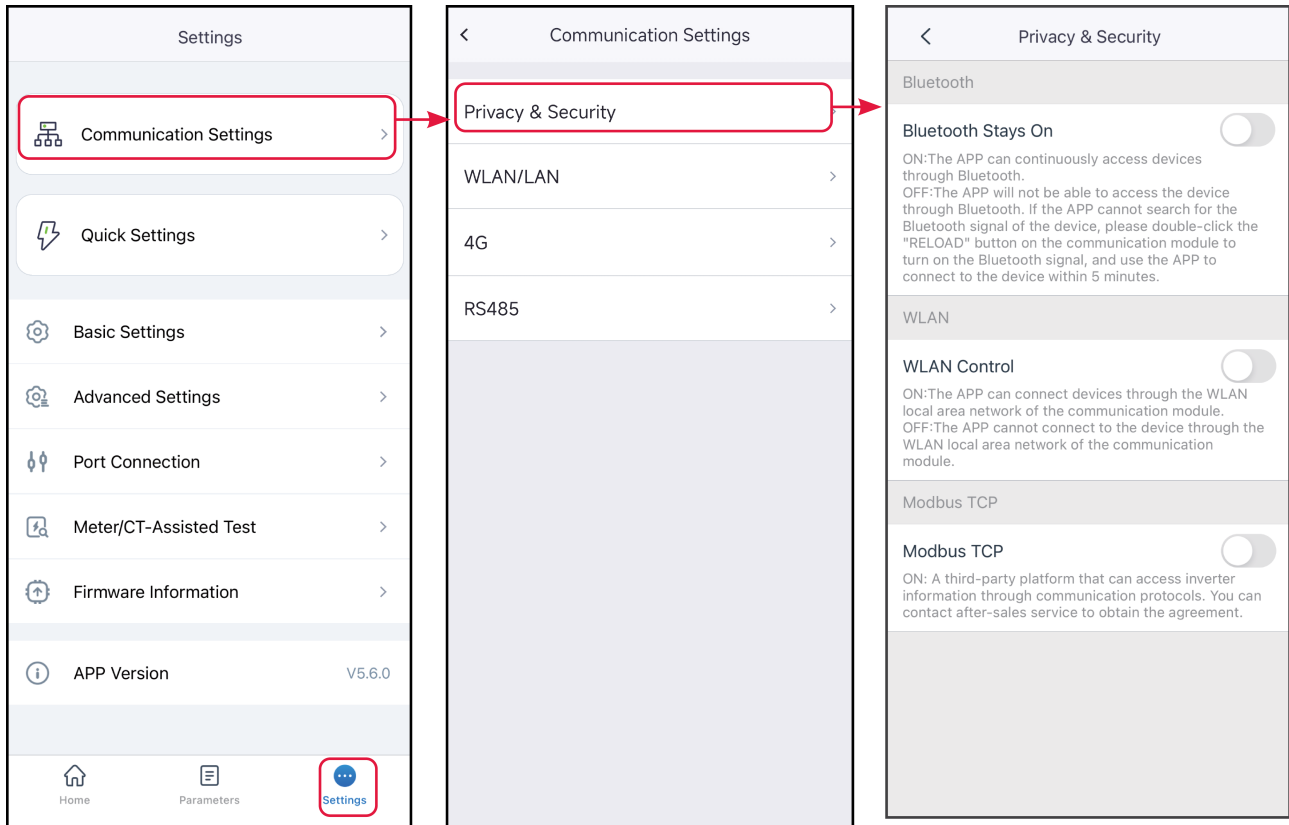

No.	Parameters	Description
1	Bluetooth Stays On	Disabled by default. Enable the function, the bluetooth of the device will be contentious on to keep connected to SolarGo. Otherwise, the bluetooth will be off in 5 minutes, and the device will be disconnected from SolarGo.
2	WLAN Control	Disabled by default. Enable the function, the device and the SolarGo can be connected through the WLAN when they are on the same LAN. Otherwise, they cannot be connected even if they are on the same LAN.
3	Modbus-TCP	Enable the function, the third party monitoring platform can access inverter through Modbus-TCP communication protocol.
4	SSH control Ezlink	After enabling this function, third-party platforms can connect to and control EzLink's Linux system.

### Type III

**Step 1 :** Tap **Home > Settings > Communication Setting > Privacy & Security** to set

the parameters.

**Step 2 : Enable Bluetooth Stays On or Login Password based on actual needs.**

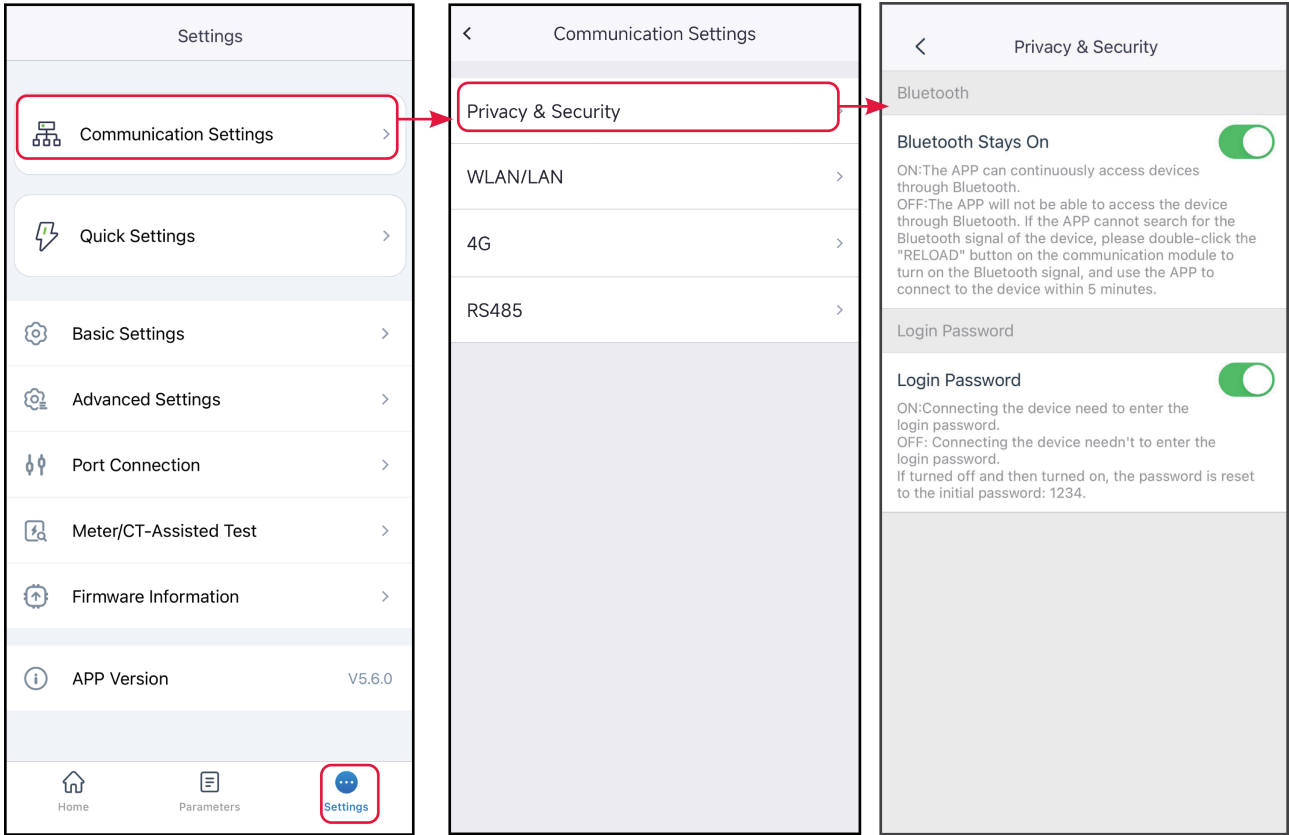

No.	Parameters	Description
1	Bluetooth Stays On	Disabled by default. Enable the function, the bluetooth of the device will be contentious on to keep connected to SolarGo. Otherwise, the bluetooth will be off in 5 minutes, and the device will be disconnected from SolarGo.
2	Password	Disabled by default. Enable the function, you will be prompted to enter the login password when connecting the device to SolarGo. Use the initial password and change it at the first login prompt.

**9.3.4.2 Setting WLAN/LAN Parameters**

## NOTICE

When the inverter is connected to different communication modules, the communication configuration interface may be different. Please refer to the actual interface.

**Step 1 :** Tap **Home > Settings > Communication Setting > WLAN/LAN** to set the parameters.

**Step 2 :** Configure the WLAN or LAN parameters based on actual needs.

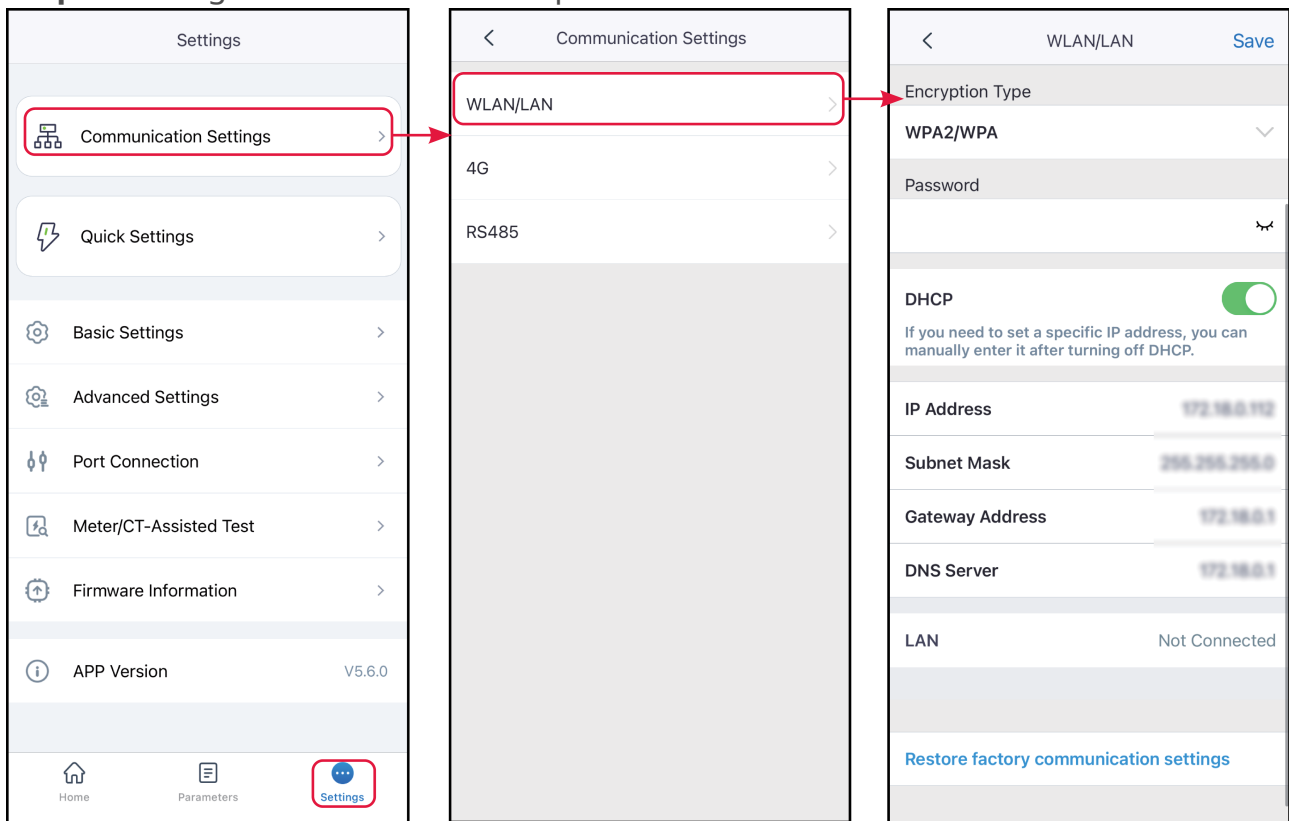

No.	Parameters	Description
1	Network Name	Only for WLAN. Select WiFi based on the actual connecting.
2	Password	Only for WLAN. WiFi password for the actual connected network.
3	DHCP	Enable DHCP when the router is in dynamic IP mode. Disable DHCP when a switch is used or the router is in static IP mode.



No.	Parameters	Description
4	IP Address	Do not configure the parameters when DHCP is enabled. Configure the parameters according to the router or switch information when DHCP is disabled.
5	Subnet Mask	
6	Gateway Address	
7	DNS Server	

### 9.3.4.3 Configuring APN Parameters

#### NOTICE

- Configure the SIM card information of 4G communication device.
- If the 4G module does not offer bluetooth signal, please configure the APN parameters through the Bluetooth module or WiFi module first to achieve 4G communication.

**Step 1:** Tap **Home > Settings > Communication Settings > 4G** to set the parameters.

**Step 2:** Set the region and operator based on actual needs.

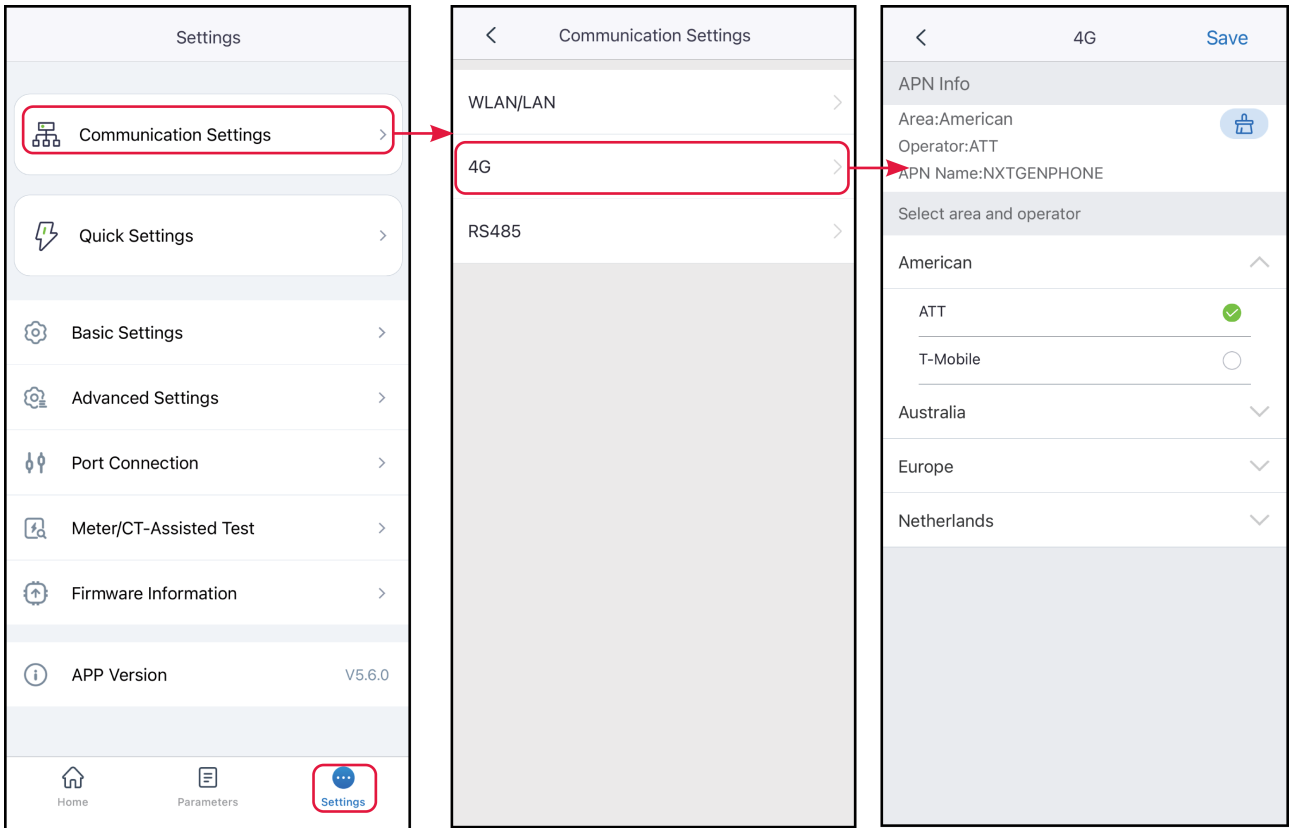

### 9.3.4.4 Configuring RS485 Parameters

#### NOTICE

Set the communication address of the inverter. For a single inverter, the address is set based on actual needs. For multi connected inverters, the address of each inverter should be different while cannot be 247.

**Step 1:** Tap **Home > Settings > Communication Settings > RS485** to set the parameters.

**Step 2 :** Set the Modbus Address And Baud Rate base on actual situation.

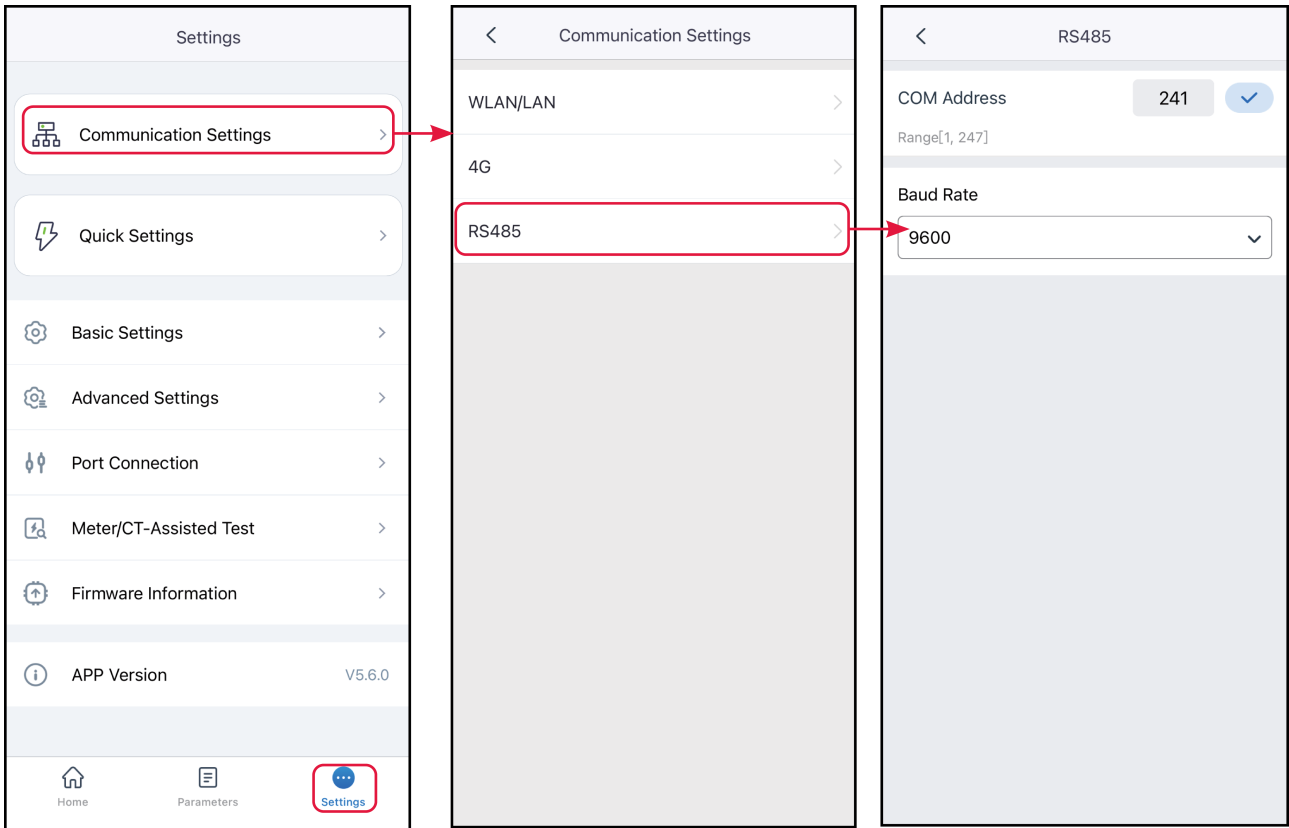

### 9.3.5 Quick Setting the Basic Information

## NOTICE

- The setting page varies depending on inverter model.
- The parameters will be configured automatically after selecting the safety country/region, including overvoltage protection, undervoltage protection, overfrequency protection, underfrequency protection, voltage/frequency connection protection,  $\cos\phi$  curve, Q(U) curve, P(U) curve, FP curve, HVRT, LVRT, etc. Tap Home > Settings > Advanced Settings > Safety Parameters to check the parameters after selecting the safety country.
- The power generation efficiency is different in different working modes. Set the working mode according to the local requirements and situation.
  - Self-use mode: The basic working mode of the system. PV power generation is used to supply power to the load first, the excess power is used to charge the battery, and the remaining power is sold to the grid. When PV power generation cannot meet the load's power demand, the battery will supply power to the load; when the battery power also cannot meet the load's power demand, the grid will supply power to the load.
  - Back-up mode: The back-up mode is mainly applied to the scenario where the grid is unstable. When the grid is disconnected, the inverter turns to off-grid mode and the battery will supply power to the load; when the grid is restored, the inverter switches to grid-tied mode.
  - Economic mode: It is recommended to use economic mode in scenarios when the peak-valley electricity price varies a lot. Select Economic mode only when it meets the local laws and regulations. Set the battery to charge mode during Vally period to charge battery with grid power. And set the battery to discharge mode during Peak period to power the load with the battery.
  - Off-grid mode: suitable for areas without power grid. PV and batteries form a pure off-grid system. PV generates electricity to power the load and excess electricity charges the battery. When PV power generation cannot meet the power demand of the load, the battery will supply power to the load.
  - Smart charging: In some countries/regions, the PV power feed into the utility grid is limited. Select Smart Charging to charge the battery using the surplus power to minimize PV power waste.
  - Peak shaving mode: Peak shaving mode is mainly applicable to peak power limited scenarios. When the total power consumption of the load exceeds the power consumption quota in a short period of time, battery discharge can be used to reduce the power exceeding the quota.

### 9.3.5.1 Quick Setting the Basic Information( Type III)

**Step 1:** Tap **Home > Settings > Quick Settings** to set the parameters.

**Step 2 :** Enter the password for quick settings. Contact the supplier or after sales service for password. Password for professional technicians only.

**Step 3:** Select safety country accordingly. Tap **Next** to set the Battery Connect Mode.

**Step 4 :** Select the actual mode in which the battery is connected to the inverter. The basic settings are completed if there is no battery connected in the system. Tap **Next** to set the Battery Model if there is any battery connected in the system.

**Step 5:** Select the actual battery model. Tap **Next** to set the Working Mode.

**Step 6:**Set the working mode based on actual needs. Tap **Next** to conduct System Self-Test.

- If Peakshaving mode is selected, tap Settings to set the parameters.

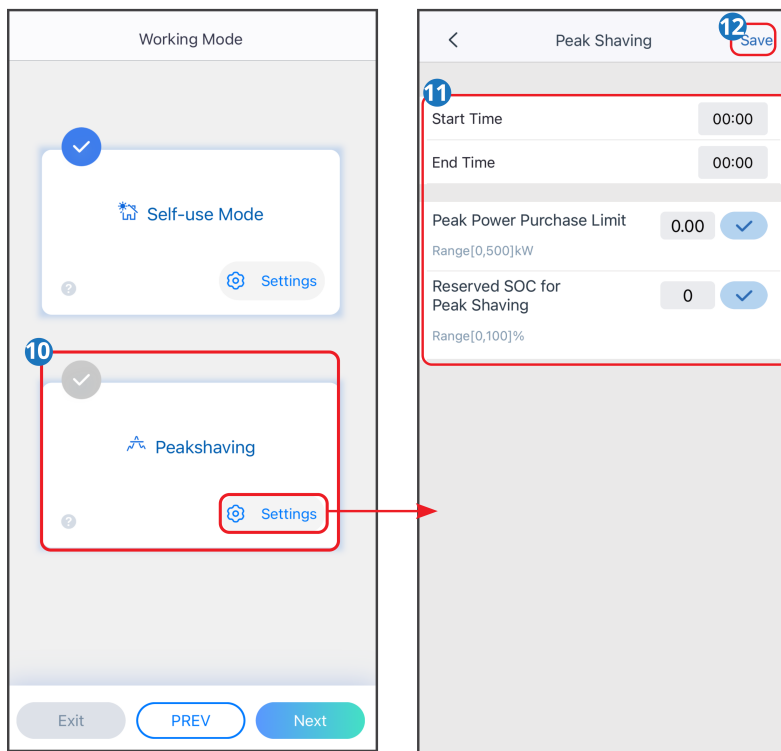

No.	Parameters	Description
Peakshaving		
1	Start Time	

No.	Parameters	Description
2	End Time	The utility grid will charge the battery between Start Time and End Time if the load power consumption do not exceed the power quota. Otherwise, only PV power can be used to charge the battery.
3	Peak Power Purchase Limit	Set the maximum power limit allowed to purchase from the grid. When the loads consume power exceed the sum of the power generated in the PV system and Peak Power Purchase Limit, the excess power will be made up by the battery.
4	Reserved SOC For Peakshaving	In Peak Shaving mode, the battery SOC should be lower than Reserved SOC For Peakshaving. Once the battery SOC is higher than Reserved SOC For Peakshaving, the peak shaving mode fails.

- When Self-Use Mode is selected, tap Settings to set the Depth Of Discharge(On-Grid)and Depth Of Discharge(Off-Grid). And tap Advanced Settings to set Back-Up Mode, TOU Mode or Smart Charging based on actual needs. If TOU Mode is selected, tap Add to set the working time and working mode of the battery group.

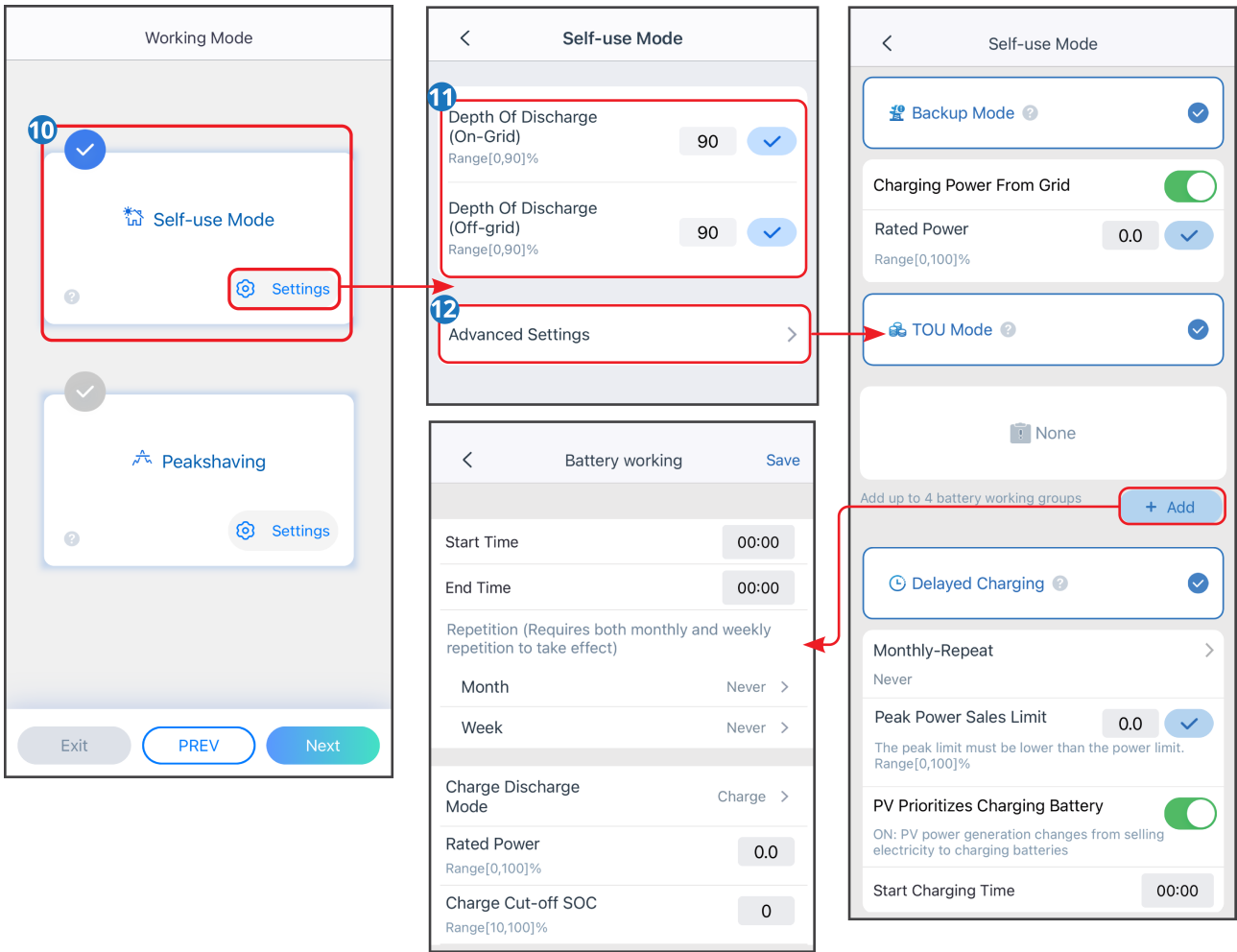

No.	Parameters	Description
Self-use mode		
1	Depth Of Discharge (On-Grid)	The maximum depth of discharge of the battery when the system is working on-grid.
2	Depth Of Discharge (Off-grid)	The maximum depth of discharge of the battery when the system is working off-grid.
Back-up mode		
3	Charging Power From Grid	Enable Charging Power From Grid to allow power purchasing from the utility grid.
4	Rated Power	The percentage of the purchasing power to the rated power of the inverter.

No.	Parameters	Description
TOU mode		
5	Start Time	Within the Start Time and End Time, the battery is charged or discharged according to the set Battery Mode as well as the Rated Power.
6	End Time	
7	Charge Discharge Mode	Charge or discharge according to actual needs.
8	Rated Power	The percentage of the charging/discharging power to the rated power of the inverter.
9	Charge Cut-off SOC	The battery stop charging/discharging once the battery SOC reaches Charge Cut-off SOC.
Smart charging		
10	Monthly-Repeat	Set the smart charging months. More than one month can be set.
11	Peak Power Sales Limit	Set the Peak Power Sales Limit in compliance with local laws and regulations. The Peak Limiting Power shall be lower then the output power limit specified by local requirements.
12	PV Prioritizes Charing Battery	During charging time, the PV power will first charge the battery.
13	Start Charging Time	

**Step 7:** Execute device self-check or skip it based on actual needs.

**Step 8 :** Tap **Recheck** or **Next** to complete the test based on your actual needs. Tap Export to export the test reports if needed.

**Step 9 :** Tap **Complete** to complete the quick settings.



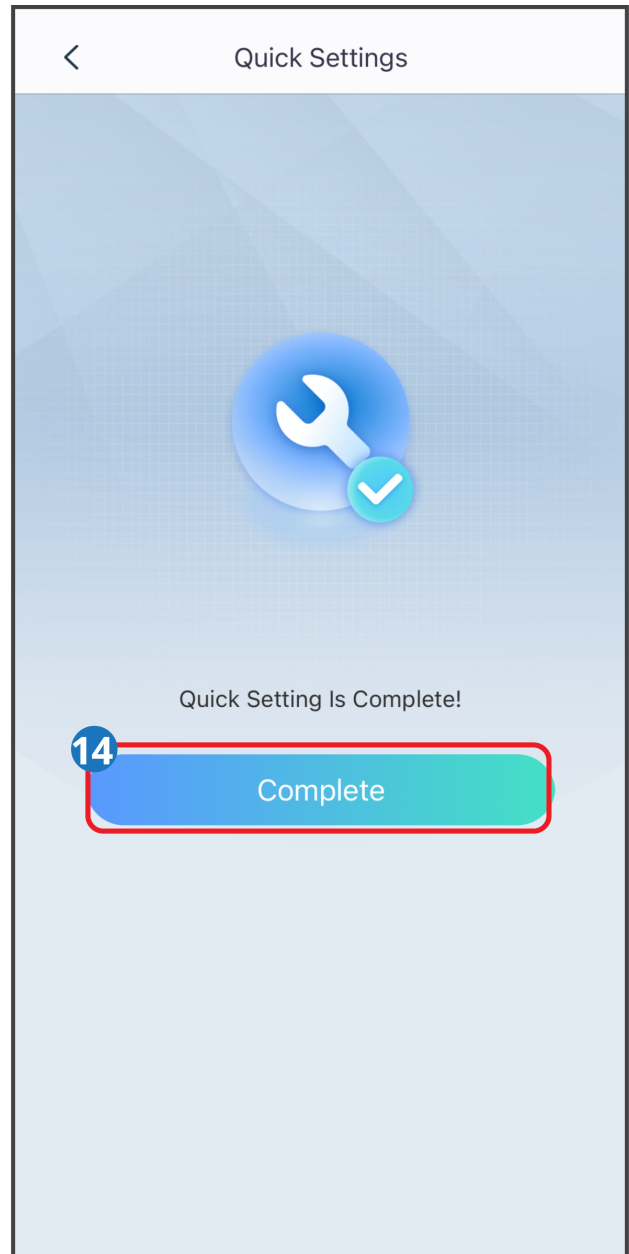
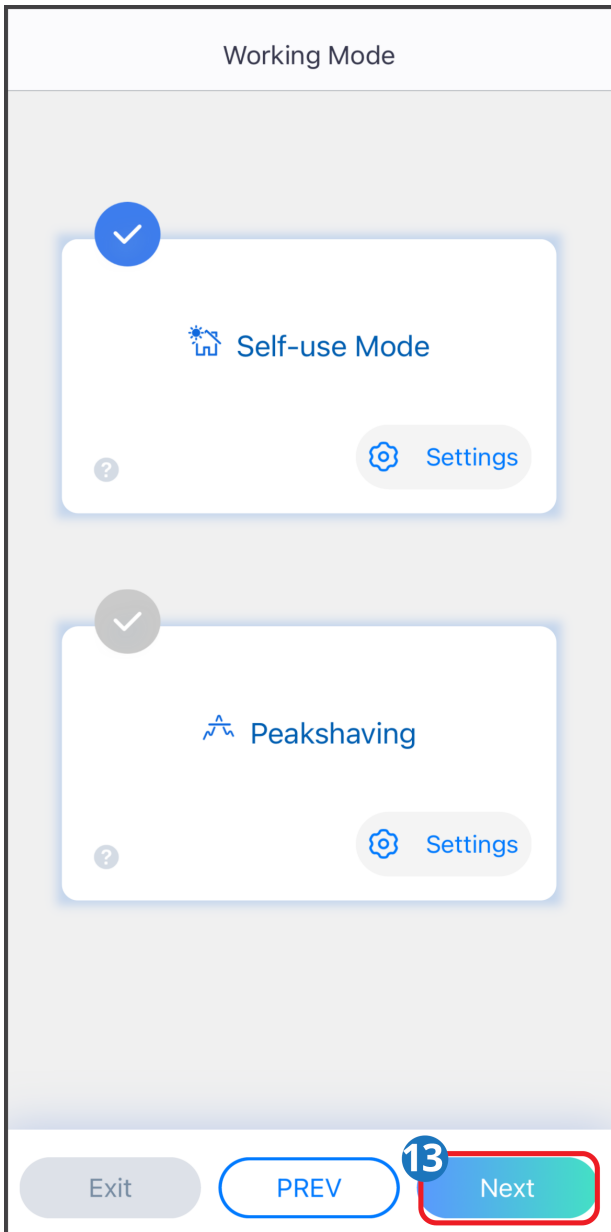

## 9.3.6 Setting the Basic Information

### 9.3.6.1 Setting the SPD

After enabling SPD, when the SPD module is abnormal, there will be SPD module abnormal alarm prompt.

**Step 1** : Tap **Home** > **Settings** > **Basic Settings** > **SPD**, to set the parameters.

**Step 2** : enable or disable the function based on actual needs.

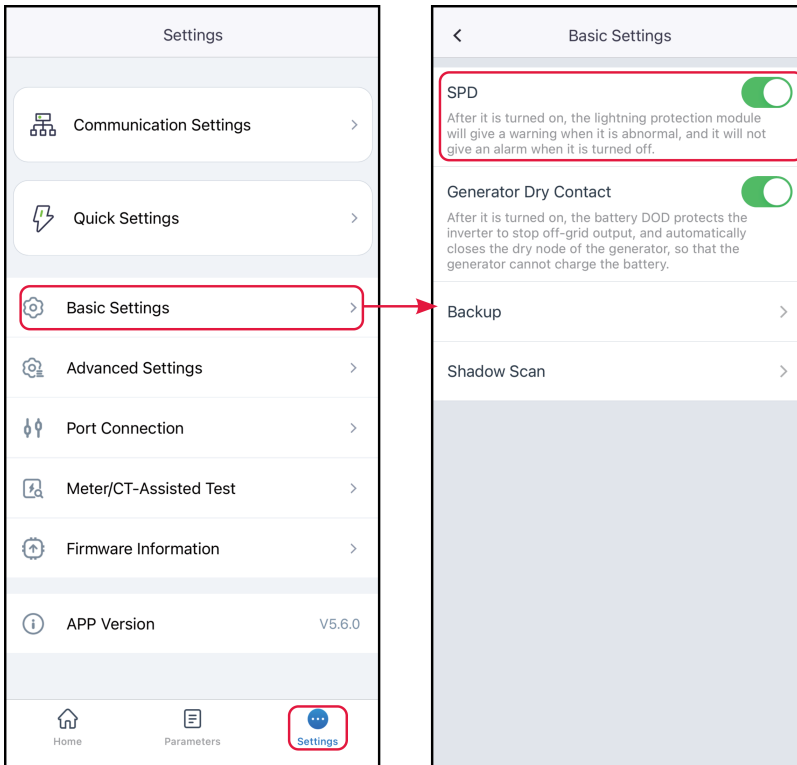

### 9.3.6.2 Setting the Shadow Scan

Enable Shadow Scan when the PV panels are severely shadowed to optimize the power generation efficiency.

**Step 1 :** Tap **Home > Settings > Basic Settings> Shadow Scan**, to set the parameters.

**Step 2:** Enable or disable the function based on actual needs. Set the Shadow Scan interval and MPPT shadow scan if the inverter supports.

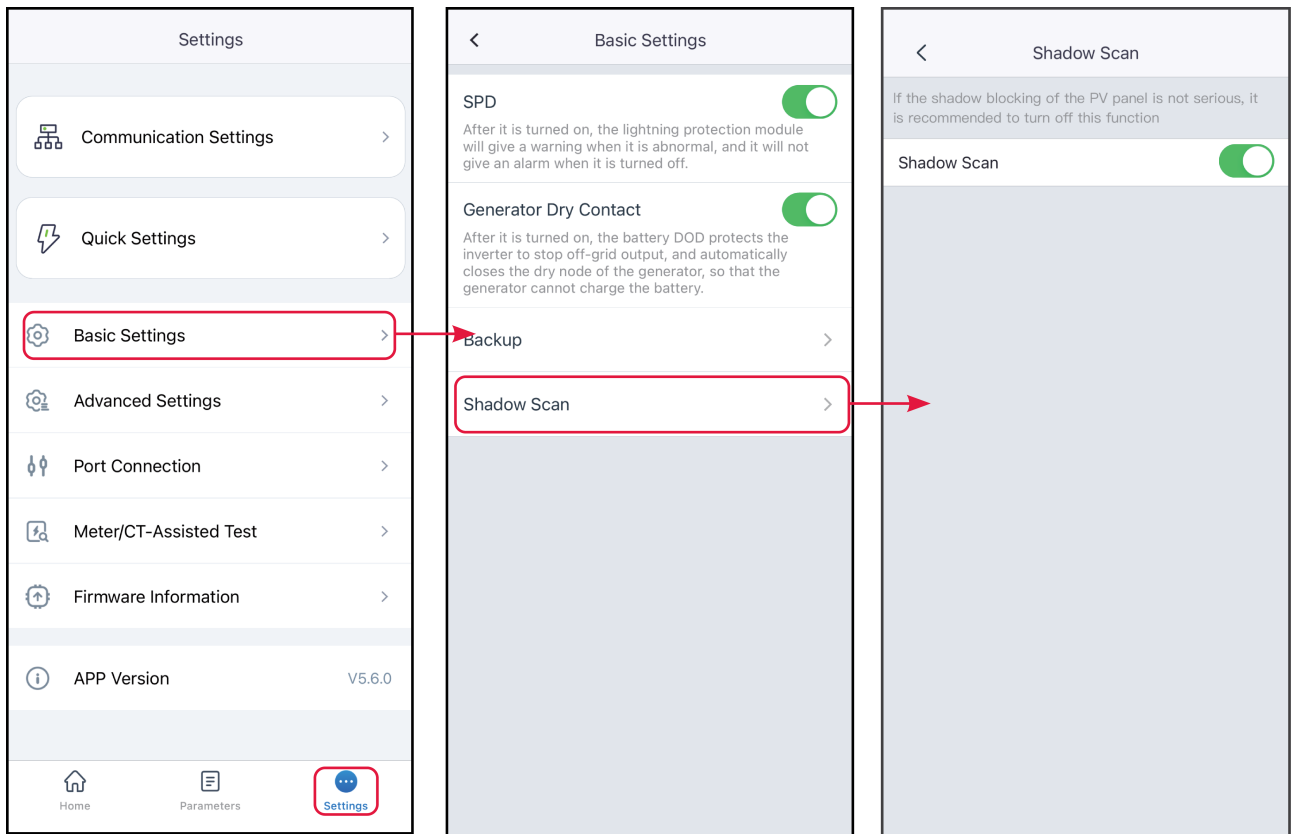

### 9.3.6.3 Setting the Back-up Power Parameters

After enabling Backup, the battery will power the load connected to the backup port of the inverter to ensure Uninterrupted Power Supply when the power grid fails.

**Step 1 :** Tap **Home > Settings > Basic Settings > Backup**, to set the parameters.

**Step 2 :** Set the backup supply function based on actual needs.

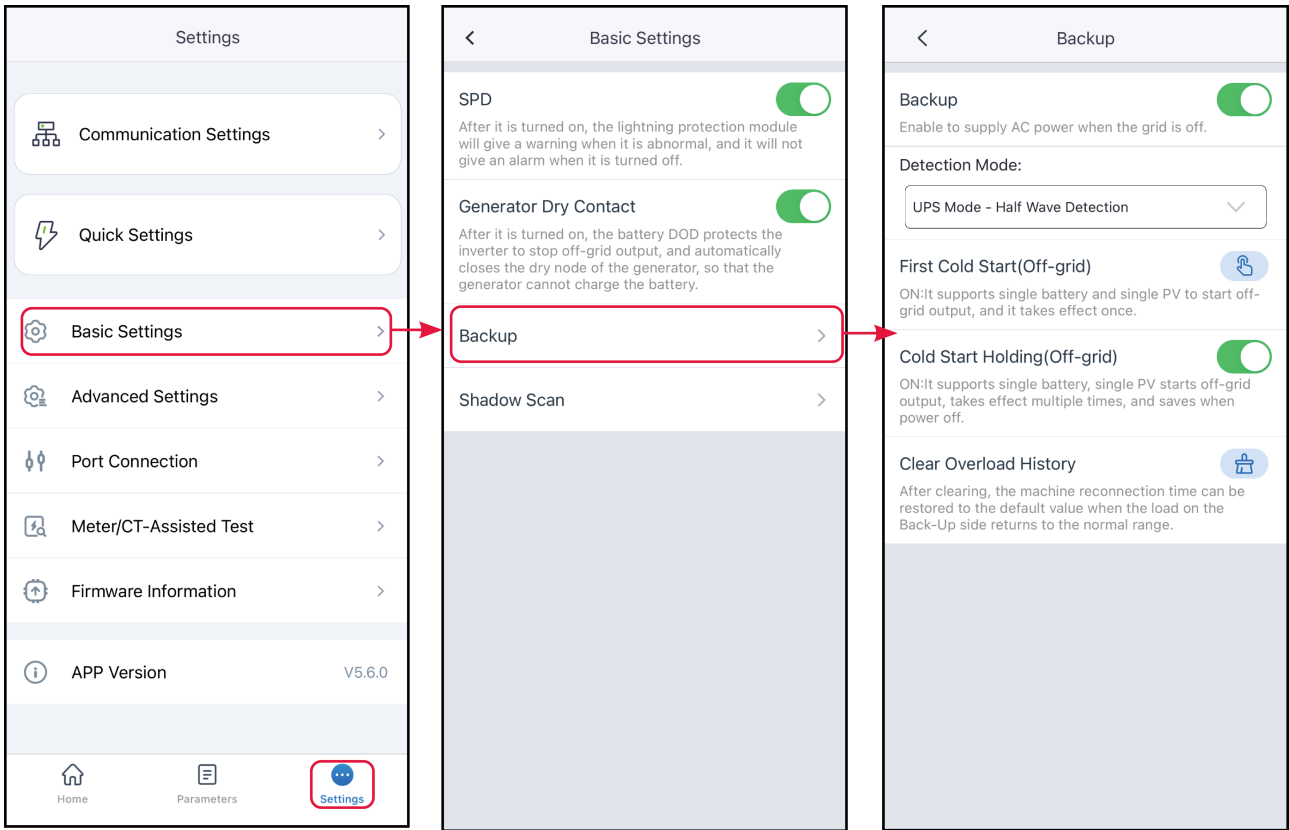

No.	Parameters	Description
1	UPS Mode- Full Wave Detection	Check whether the utility grid voltage is too high or too low.
2	UPS Mode- Half Wave Detection	Check whether the utility grid voltage is too low.
3	EPSmode-with LVRT support.	Stop detecting utility grid voltage.
4	First Cold Start (Off-grid)	It will only take effect once. In off-grid mode, enable First Cold Start (Off-grid) to output backup supply with battery or PV.
5	Cold Start Holding (Off-grid)	Take effect multiple times. In off-grid mode, enable First Cold Start (Off-grid) to output backup supply with battery or PV.

No.	Parameters	Description
6	Clear Overload History	Once the power of loads connected to the inverter BACK-UP ports exceeds the rated load power, the inverter will restart and detect the power again. The inverter will perform restart and detection several times until the overloading problem is solved. Tap Clear Overload History to reset the restart time interval after the power of the loads connected to the BACK-UP ports meets the requirements. The inverter will restart immediately.

### 9.3.7 Setting Advanced Parameters

#### NOTICE

Contact the supplier or after sales service for Advanced Setting password.  
Password for professional technicians only.

#### 9.3.7.1 Setting DRED/Remote Shutdown/RCR/EnWG 14a

Enable DRED/Remote Shutdown/RCR before connecting the third party DRED, remote shutdown, or RCR device to comply with local laws and regulations.

**Step 1** : Tap **Home > Settings > Advanced Settings > DRED/Remote Shutdown/RCR** to set the parameters.

**Step 2** : Enable or disable the function based on actual needs.

**Step 3** : For areas where the EnWG 14a regulation applies, when enabling the RCR function, you need to select the RCR mode according to the actual device type and set the DI port power.

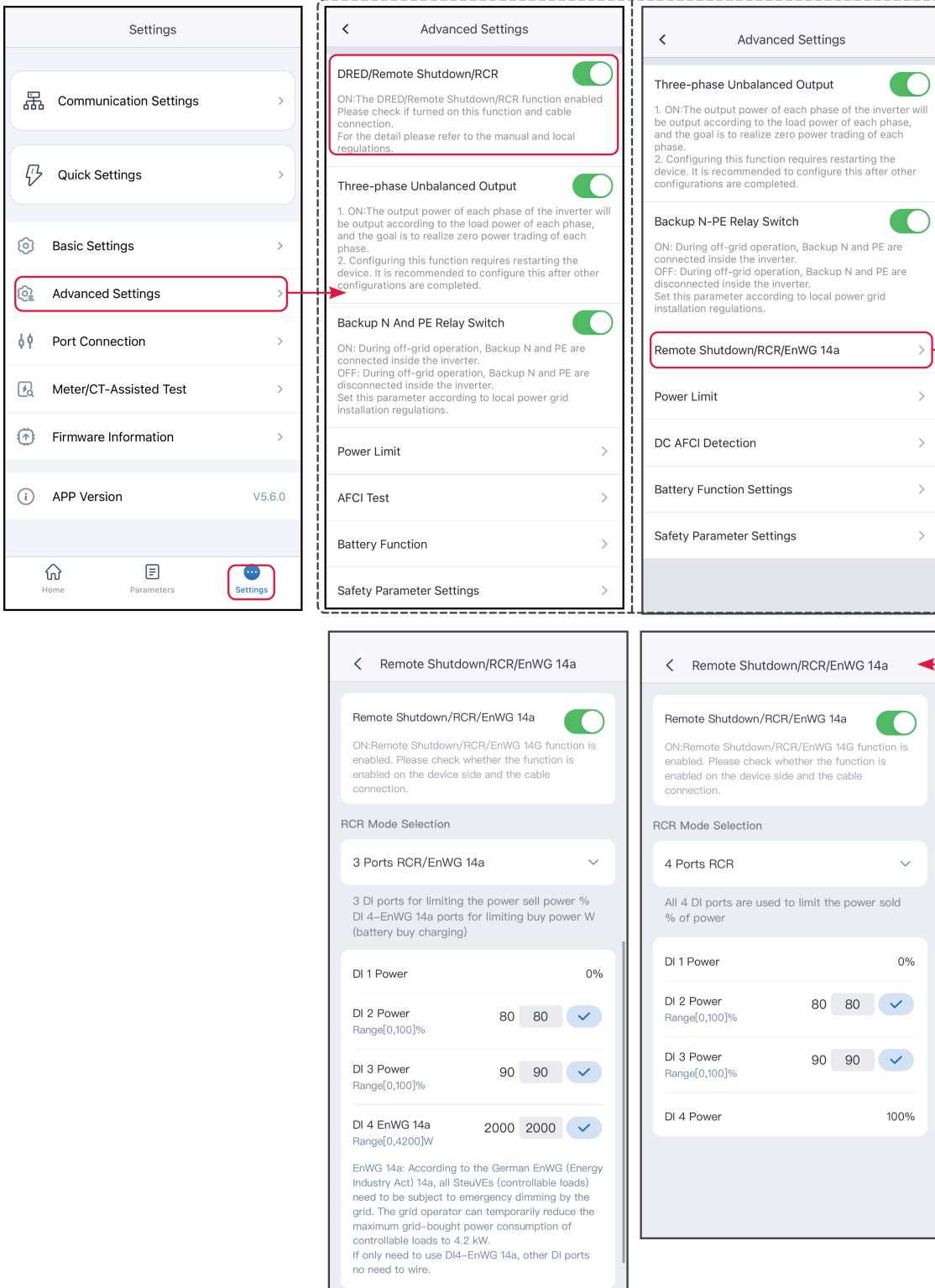

### 9.3.7.2 Setting the Backup N and PE Relay Switch

To comply with local laws and regulations, ensure that the relay inside the back-up

port remains closed and the N and PE wires are connected when the inverter is working off-grid.

**Step 1 :** Tap **Home > Settings > Advanced Settings > Backup N and PE Relay Switch** to set the parameters.

**Step 2 :** Enable or disable the function based on actual needs.

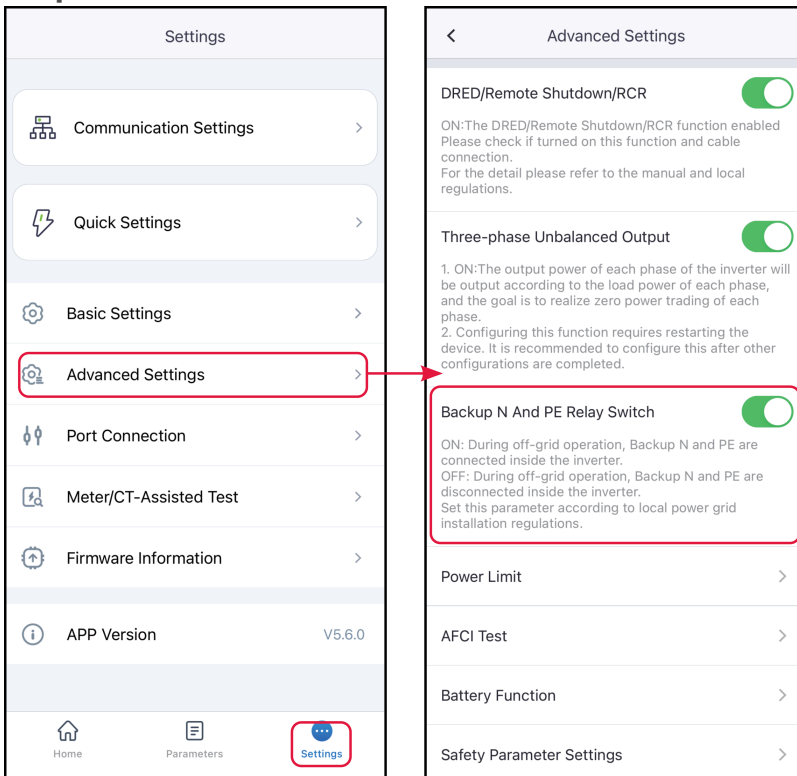

### 9.3.7.3 Setting the Power Limit Parameters

**Step 1:** Tap **Home > Settings > Advanced Settings > Power Limit** to set the parameters.

**Step 2 :** Turn on or off the power limit function according to actual needs.

**Step 3 :** After turning on the function, enter the parameter value according to actual needs and tap "v" to successfully set the parameter.

#### 9.3.7.3.1 Set the grid-connected power limit parameters (general)

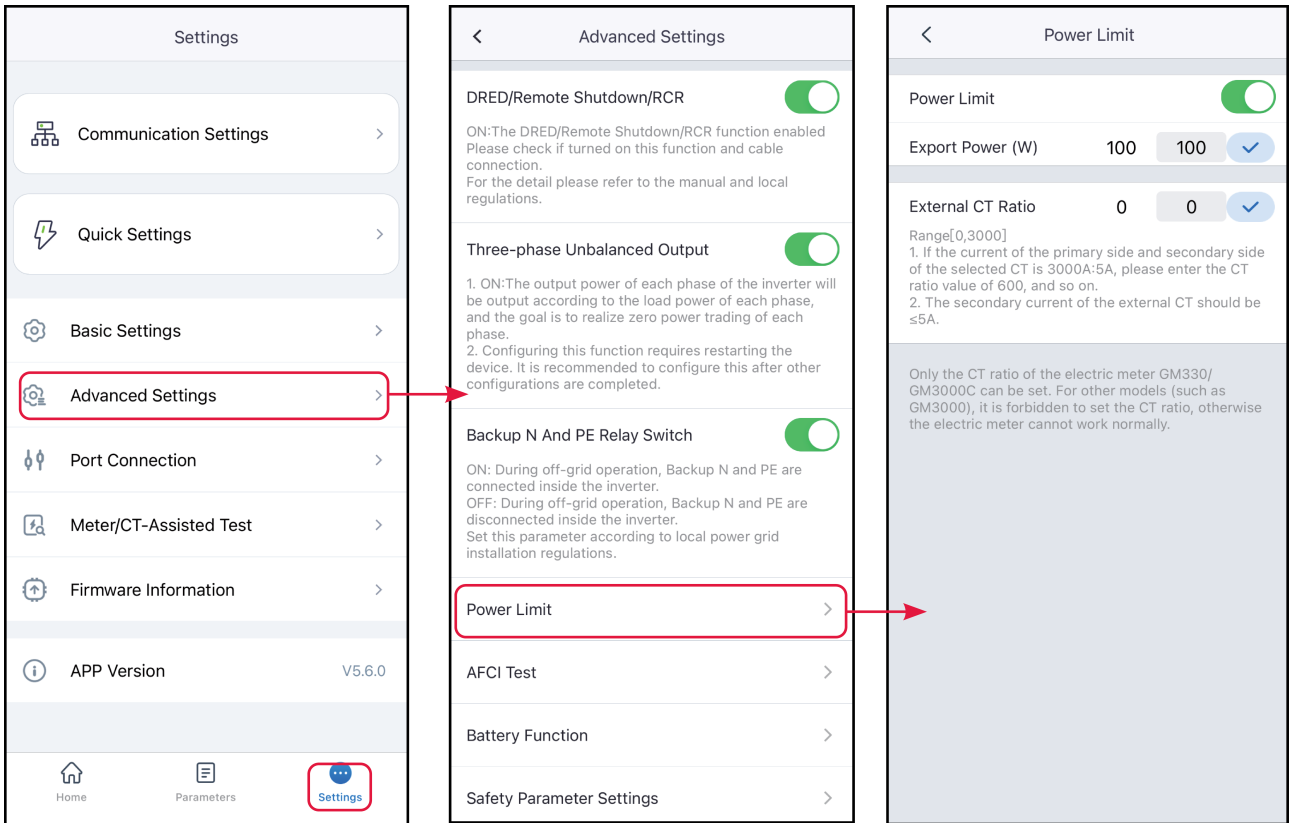

No.	Parameters	Description
1	Power Limit	Turn on this function when output power needs to be limited according to the grid standards of some countries or regions.
2	Export Power	Set according to the maximum power that can be input to the grid.
3	External Meter CT ratio	Set the ratio of the primary current to the secondary current of the external CT.

### 9.3.7.3.2 Setting the Power Limit Parameters (Australia)



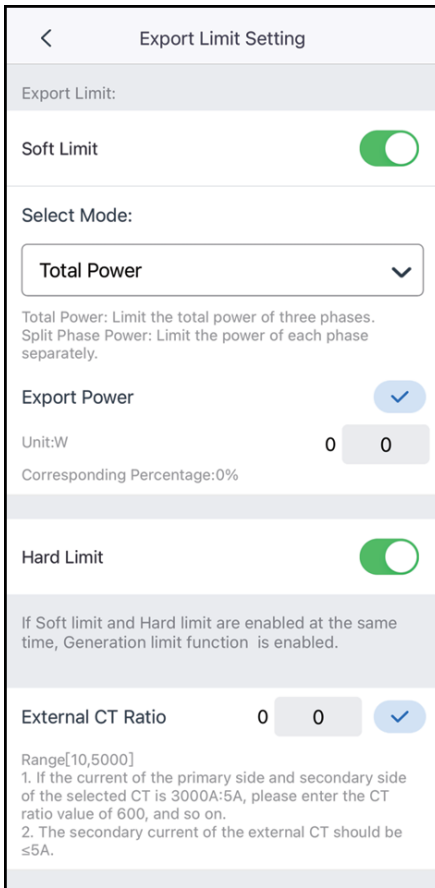

SLG00CON0133

No.	Parameters	Description
1	Software Power Limit	When output power needs to be limited according to grid standards in some countries or regions, turn on this function.
2	Limit Setting	<ul style="list-style-type: none"> <li>• Set according to the maximum power that can be actually input to the grid.</li> <li>• Supports setting of fixed power value or percentage. The set percentage is the percentage of the limit power to the rated power of the inverter.</li> <li>• After setting the fixed value, the percentage changes automatically; after setting the percentage, the fixed value changes automatically.</li> </ul>

No.	Parameters	Description
3	Hardware Power Limit	After enabling this function, when the amount of electricity fed into the grid exceeds the limit value, the inverter will automatically disconnect from the grid.
4	External Meter CT Ratio	Set the ratio of the primary current to the secondary current of the external CT.

### 9.3.7.4 Setting the AFCI Detection

**Step 1 :** Tap Home > Settings > Advanced Settings > AFCI Test to set the parameters.

**Step 2 :** Enable AFCI Test, Clear AFCI Alarm and Self-Check based on actual needs.

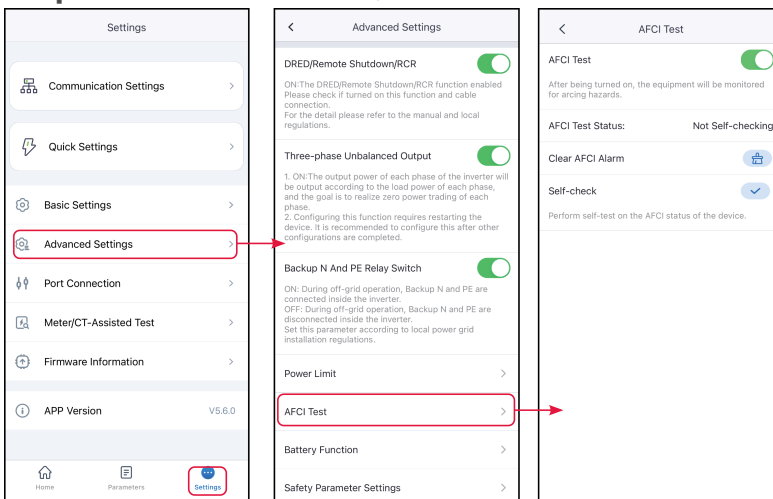

No.	Parameters	Description
1	AFCI Test	Enable or disable AFCI accordingly.
2	AFCI Test Status	The detection status like Not Self-checking.
3	Clear AFCI Alarm	Clear ARC Faulty alarm records.
4	Self-check	Tap to check whether the AFCI function works normally.

### 9.3.7.5 Setting the Battery

### 9.3.7.5.1 Set Parameters for Lithium Battery

**Step 1:** Tap **Home > Settings> Advanced Settings > Battery Function Settings** to set the parameters.

**Step 2:** Set the parameters based on actual needs.

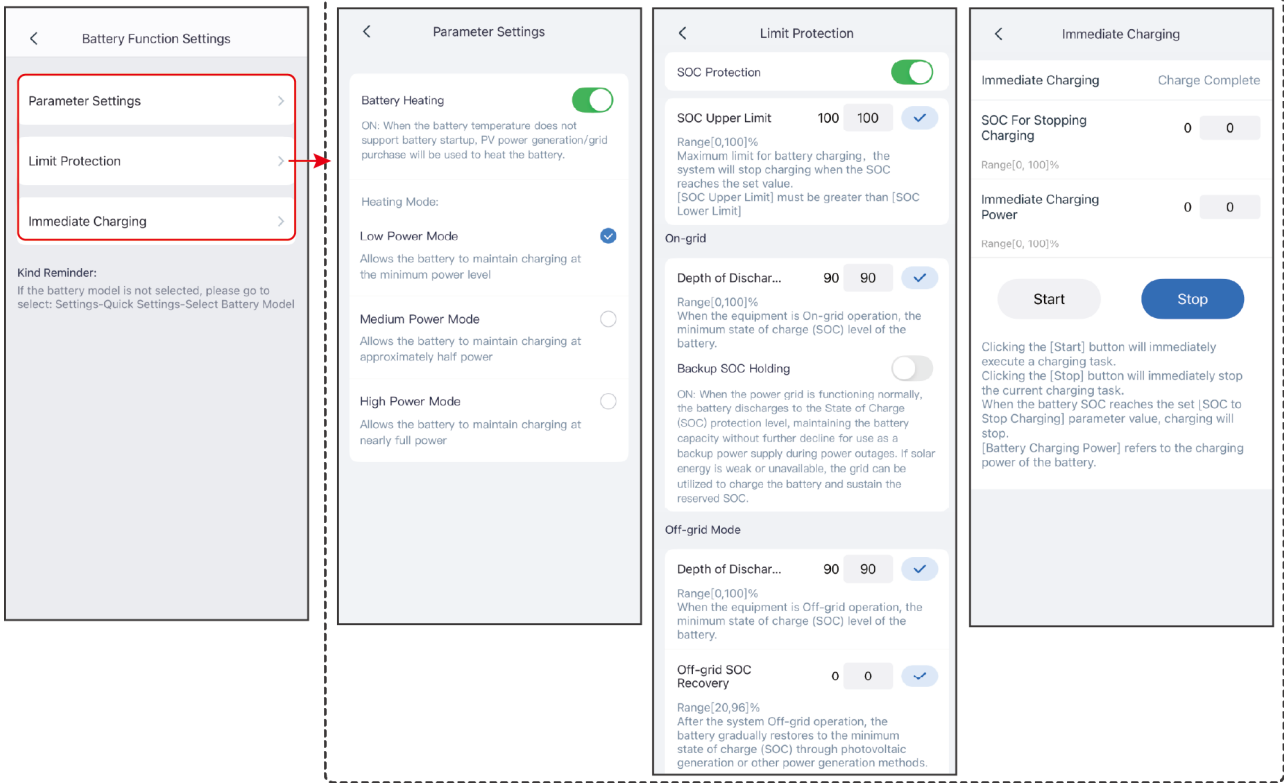

SLG00CON0072

No.	Parameter	Description
Parameter Settings		
1	Max. Charging Current	Only applicable to certain models. Set the maximum charging current based on actual needs.
2	Max. Discharging Current	Only applicable to certain models. Set the maximum discharging current based on actual needs.

No.	Parameter	Description
3	Battery Heating	<p>Optional. This option is displayed on the interface when a battery that supports heating is connected. After the battery heating function is turned on, when the temperature is below the value that starts up the battery, PV power or electricity from the grid will be used to heat the battery.</p> <p>Heating Mode:</p> <ul style="list-style-type: none"> <li>• GW5.1-BAT-D-G20/GW8.3-BAT-D-G20 <ul style="list-style-type: none"> <li>◦ Low Power Mode: Maintains minimum battery power input capacity, turns on when the temperature is below -9°C, and turns off when the temperature is above or equal to -7°C.</li> <li>◦ Medium Power Mode: to maintain the moderate power input capacity of the battery. It will be turned on when the temperature is less than 6°C, and turned off when it is greater than or equal to 8°C.</li> <li>◦ High Power Mode: to maintain the higher power input capacity of the battery. It will be turned on when the temperature is less than 11°C, and turned off when it is greater than or equal to 13°C.</li> </ul> </li> <li>• GW14.3-BAT-LV-G10 <ul style="list-style-type: none"> <li>◦ Low Power Mode: Maintains minimum battery power input capacity, turns on when the temperature is below 5°C, and turns off when the temperature is above or equal to 7°C.</li> <li>◦ Medium Power Mode: to maintain the moderate power input capacity of the battery. It will be turned on when the temperature is less than 10°C, and turned off when it is greater than or equal to 12°C.</li> <li>◦ High Power Mode: to maintain the higher power input capacity of the battery. It will be turned on when the temperature is less than 20°C, and turned off when it is greater than or equal to 22°C.</li> </ul> </li> </ul>

No.	Parameter	Description
4	Battery Wake-up	<ul style="list-style-type: none"> <li>After being turned on, the battery can be awakened when it shuts down due to undervoltage protection.</li> <li>Only applicable to lithium batteries without circuit breakers. After being turned on, the output voltage of the battery port is about 60V.</li> </ul>
Limit Protection		
5	SOC Protection	Start battery protection when the battery capacity is lower than the Depth of Discharge.
6	SOC Limit	The upper limit value for battery charging. Charging stops when the battery SOC reaches the SOC upper limit.
7	Discharge Depth (On-grid)	The maximum discharge value allowed for the battery when the inverter is in the on-grid scenario.
8	Backup Power SOC Maintenance	To ensure that the battery SOC is sufficient to maintain normal operation when the system is off-grid, the battery will purchase electricity from the grid and charge to the set SOC protection value when the system is connected to the grid.
9	Discharge Depth (Off-grid)	The maximum discharge value allowed for the battery when the inverter is in the off-grid scenario.
10	Off-grid SOC Recovery	When the inverter is operating off-grid, if the battery SOC drops below the lower limit, the inverter stops outputting power and only charges the battery until the battery SOC returns to the off-grid recovery SOC value. If the SOC lower limit value is higher than the off-grid recovery SOC value, charge to SOC lower limit +10%.
Immediate Charging		
11	Immediate Charging	Enable to charge the battery by the grid immediately. This takes effect once. Enable or Disable based on actual needs.

No.	Parameter	Description
12	SOC for Stopping Charging	Stop charging the battery once the battery SOC reaches SOC For Stopping Charging.
13	Immediate Charging Power	Indicates the percentage of the charging power to the inverter rated power when enabling Immediate Charging. For example, for an inverter with a rated power of 10kW, when set to 60, the charging power is 6kW.
14	Start	Start charging immediately.
15	Stop	Immediately stop the current charging task.

#### 9.3.7.5.2 Setting Lead-acid Battery Parameter

**Step 1:** Tap **Home > Settings > Advanced Settings > Battery Function Settings** to set the parameters.

**Step 2:** Set the parameters based on actual needs.

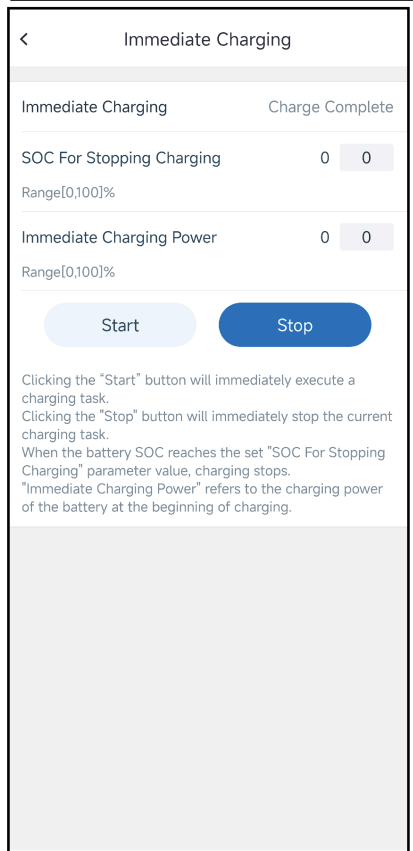
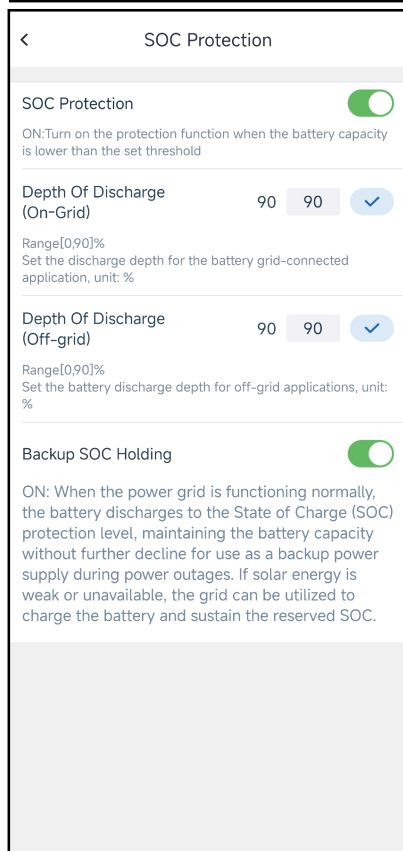
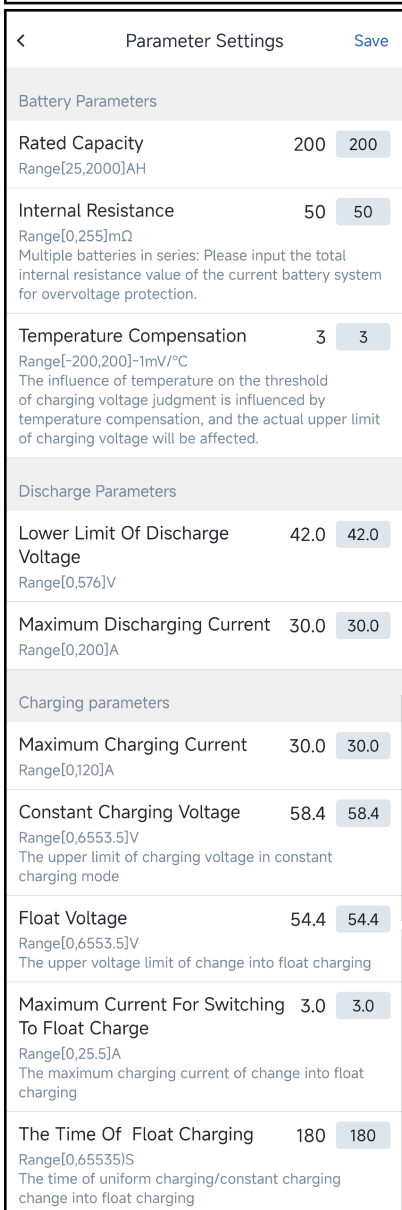
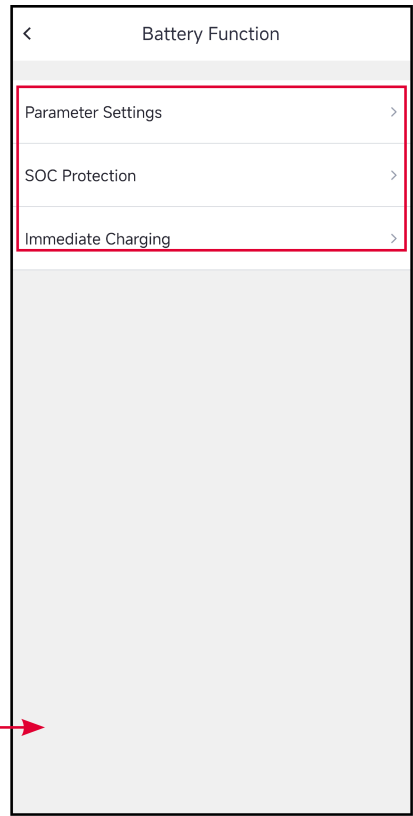
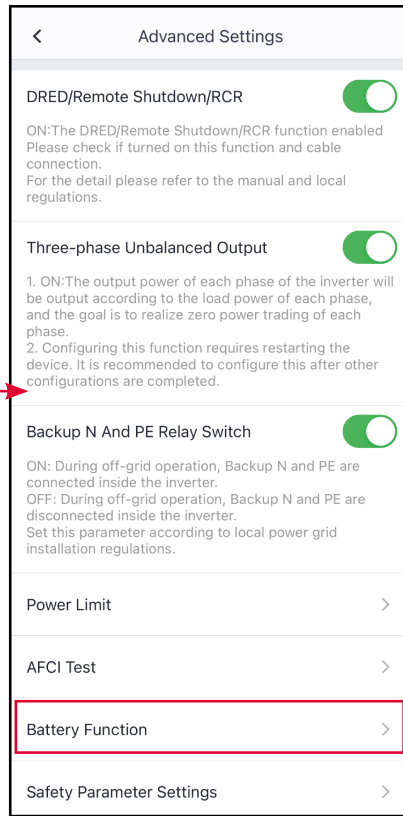
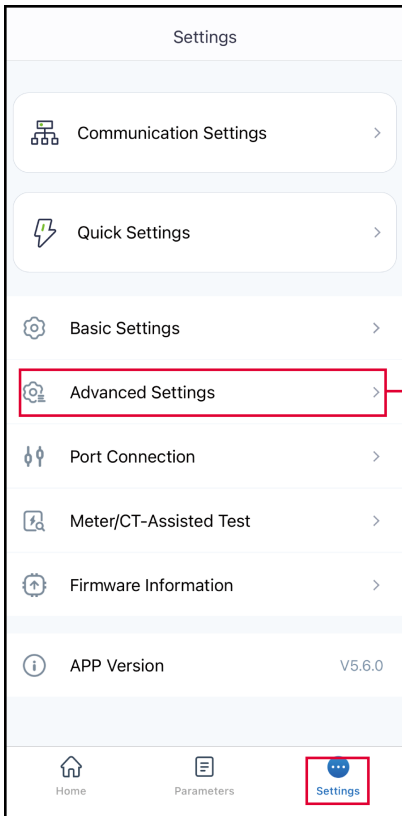

No.	Parameter	Description
1	Nominal Capacity	Set the battery capacity according to the actual parameters.
2	Battery Internal Resistance	Set the battery internal resistance according to the actual parameters.
3	Temperature Compensation	<p>When the battery temperature changes, the battery charging voltage will be affected. Based on 25°C, the charging voltage upper limit is adjusted according to the set value for every degree change in battery temperature.</p> <p>For example, if the charging temperature influence coefficient is set to 10, when the battery temperature rises to 26 degrees, the charging voltage upper limit decreases by 10 mV.</p>
4	Lower Discharge Voltage	Set the minimum voltage during battery discharge according to actual requirements.
5	Max. Discharging Current	Set the maximum discharging current based on actual needs.
6	Max. Charging Current	Set the maximum charging current based on actual needs.
7	Constant Charging Voltage	Set the voltage value for constant charging of the battery according to actual requirements.
8	Floating Voltage	Set the voltage value for battery float charging according to actual requirements.
9	Maximum Current When Switching to Floating Charge	The maximum charging current after switching the battery charging mode from constant charging/equal charging to float charging.



No.	Parameter	Description
10	Time to Switch to Float Charging Mode	The time required to switch the battery charging mode from constant charging/equal charging to float charging.
11	Equalization Charging Cycle	Set the interval days for battery equalization charging.
Restriction protection.		
12	SOC Protection	Start battery protection when the battery capacity is lower than the Depth of Discharge.
13	SOC Lower Limit (Grid Connection)	The minimum battery charge that must be maintained when the inverter is connected to the grid.
14	Backup Power SOC Maintenance	To ensure that the battery SOC is sufficient to maintain normal operation when the system is off-grid, the battery will purchase electricity from the grid and charge to the set SOC protection value when the system is connected to the grid.
15	SOC Lower Limit (Off-Grid)	The minimum battery charge that must be maintained when the inverter is operating off-grid.
16	Off-grid SOC Recovery	When the inverter is operating off-grid, if the battery SOC drops below the lower limit, the inverter stops outputting power and only charges the battery until the battery SOC returns to the off-grid recovery SOC value. If the SOC lower limit value is higher than the off-grid recovery SOC value, charge to SOC lower limit +10%.
Immediate Charging		
17	SOC for Stopping Charging	Stop charging the battery once the battery SOC reaches SOC For Stopping Charging.

No.	Parameter	Description
18	Immediate Charging Power	Indicates the percentage of the charging power to the inverter rated power when enabling Immediate Charging. For example, for an inverter with a rated power of 10kW, when set to 60, the charging power is 6kW.
19	Start	Start charging immediately.
20	Stop	Immediately stop the current charging task.

### 9.3.7.6 Setting PV Connect Mode

Select the PV connect mode based on the actual connections between the PV strings and MPPT ports of the inverter.

**Step 1** : Tap **Home > Settings > Advanced Settings > PV Connect Mode** to set the parameters.

**Step 2** : Set the connect mode to Independent Access, Partial Parallel Connect or Parallel Connection based on actual connections.

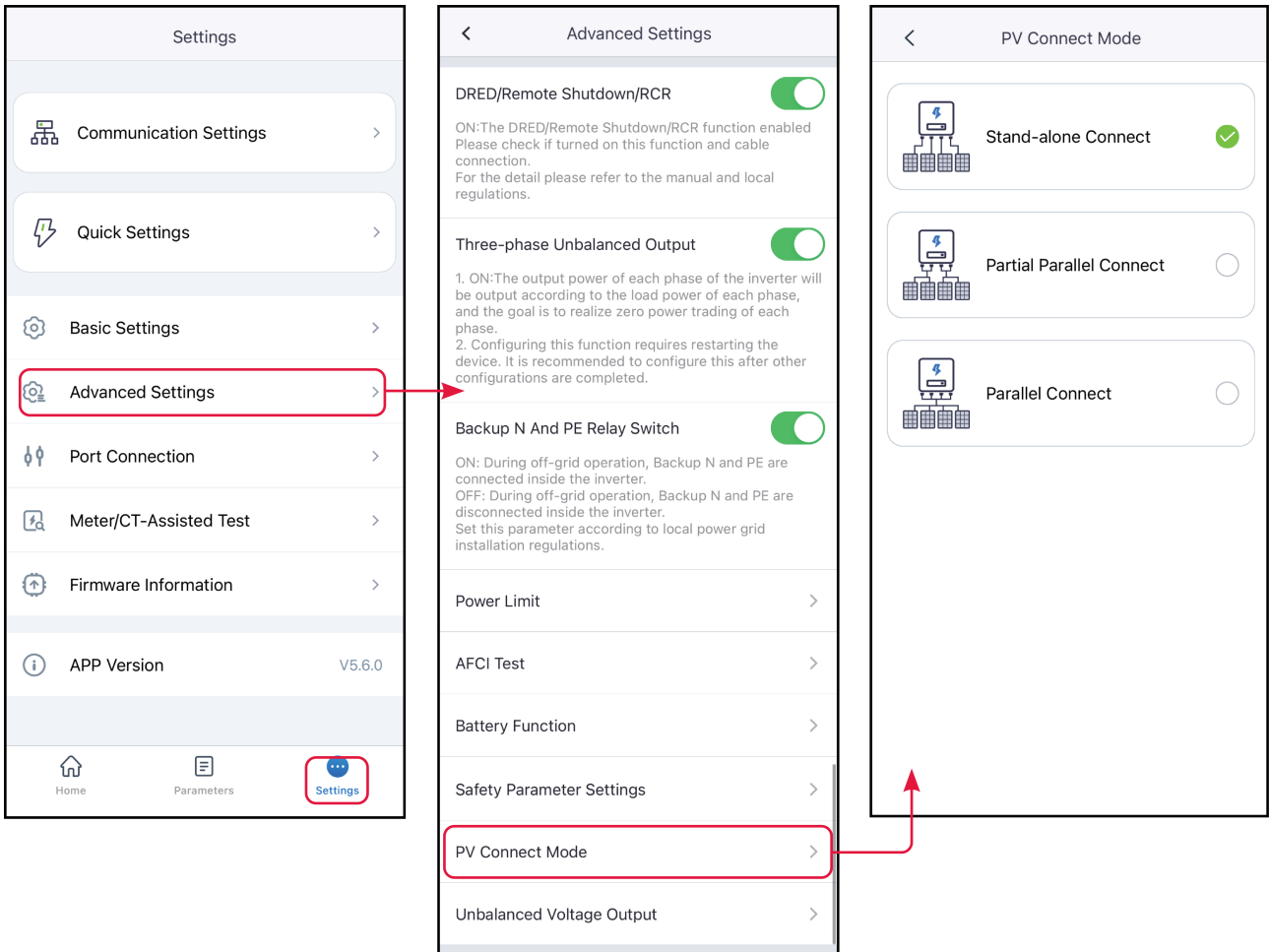

No.	Parameters	Description
1	Stand-alone Connect	The external PV string is connected to multi MPPT terminals of the inverter.
2	Partial Parallel Connect	The PV strings are connected to the inverter in both stand-alone and parallel connection. For example, one PV string connect to MPPT1 ad MPPT2, another PV string connect to MPPT3.
3	Parallel Connect	When an external PV string is connected to the PV input port on the inverter side, one PV string is connected to multiple PV input ports.

### 9.3.8 Setting Safety Parameters

## NOTICE

Set the custom safety parameters in compliance with local requirements. Do not change the parameters without the prior consent of the grid company.

### 9.3.8.1 Setting the Reactive Power Mode

**Step 1 :** Tap **Home > Settings > Advanced Settings > Safety Parameter Setting > Reactive Power Mode Settings** to set the parameters.

**Step 2 :** Set the parameters based on actual needs.

#### Q(U) Curve

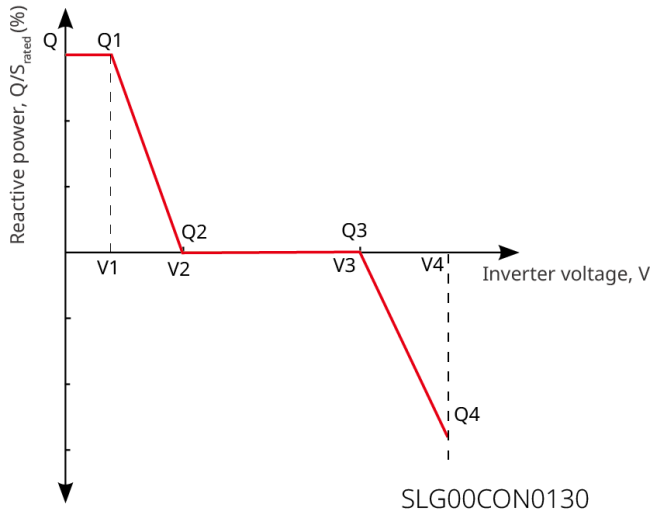

#### Cosφ Curve

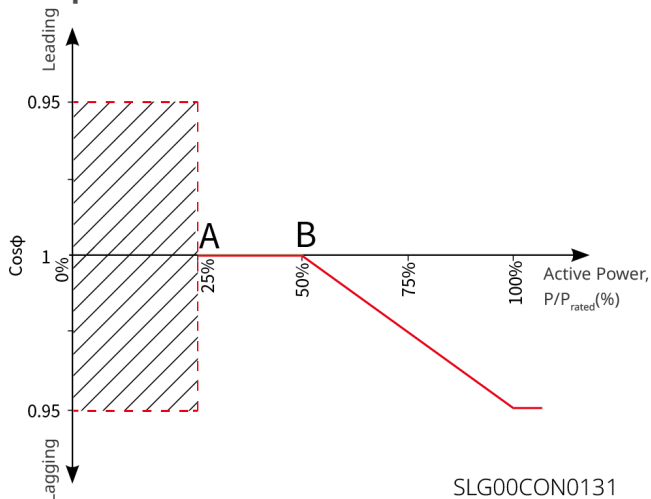

No.	Parameters	Description
Fix PF		
1	Fix PF	Enable Fix PF when it is required by local grid standards and requirements. After the parameters are set successfully, the power factor remains unchanged during the operation of the inverter.
2	Under-excited	Set the power factor as lagging or leading based on actual needs and local grid standards and requirements.
3	Over-excited	
4	Power Factor	Set the power factor based on actual needs. Range: 0~-0.8, or +0.8~+1.
Fix Q		
1	Fix Q	Enable Fix Q when it is required by local grid standards and requirements.
2	Over-excited/Under-excited	Set the reactive power as inductive or capacitive reactive power based on actual needs and local grid standards and requirements.
3	Reactive Power	Set the ratio of reactive power to apparent power.
Q(U) Curve		
1	Q(U) Curve	Enable Q(U) Curve when it is required by local grid standards and requirements.
2	Mode Selection	Set Q(U) curve mode, supporting basic mode and slope mode.
3	Vn Voltage	The percentage of actual voltage to the rated voltage at Vn point, n=1, 2, 3, 4. When set to 90, it means: $V/V_{rated}\% = 90\%$ .
4	Vn Reactive Power	The percentage of the reactive output power to the apparent power at Vn point, n=1, 2, 3, 4. For example, setting <b>Vn Reactive Power</b> to 48.5 means $Q/S_{rated}\%=48.5\%$ .

No.	Parameters	Description
5	Voltage Deadband Width	When Q(U) curve mode is set to slope mode, this parameter defines the voltage deadband range where no reactive power output is required.
6	Over-excitation Slope	(In Q(U) slope mode) Sets the positive or negative slope for reactive power variation during over-voltage conditions.
7	Under-excitation Slope	
8	Vn Reactive Power	The percentage of the reactive output power to the apparent power at Vn point, n=1, 2, 3, 4. For example, setting <b>Vn Reactive Power</b> to 48.5 means $Q/S_{rated}\%=48.5\%$ .
9	Q(U) Curve Response Time Constant	The reactive power must reach 95% of the target value within 3 time constants, following a first-order low-pass filter curve.
10	Extended Function	Enable the extended function and configure the corresponding parameters.
11	Lock-In Power	When the inverter output reactive power to the rated power ratio is between the Lock-in power and Lock-out power, the ratio meets Q(U) curve requirements.
12	Lock-out Power	
Cosφ(P) Curve		
1	Cosφ(P) Curve	Enable Cosφ Curve when it is required by local grid standards and requirements.
2	Mode Selection	Set cosφ(P) Curve Mode and support basic mode and slope mode configurations.
3	N-point Power	The percentage of inverter output active power relative to rated power at the N-point. N=A, B, C, D, E.
4	N-point cosφ Value	N-point Power Factor N=A, B, C, D, E.
5	Over-excitation Slope	

No.	Parameters	Description
6	Under-excitation Slope	When $\cos\phi(P)$ curve mode is set to slope mode, configures the power variation slope as either positive or negative.
7	N-point Power	The percentage of inverter output active power relative to rated power at the N-point. N=A, B, C.
8	N-point $\cos\phi$ Value	N-point Power Factor N=A, B, C.
9	$\cos\phi(P)$ Curve Response Time Constant	The reactive power must reach 95% of the target value within 3 time constants, following a first-order low-pass filter curve.
10	Extended Function	Enable the extended function and configure the corresponding parameters.
11	Lock-in Voltage	When the grid voltage is between Lock-in Voltage and Lock-out Voltage, the voltage meets $\cos\phi$ curve requirements.
12	Lock-out Voltage	
Q(P) Curve		
1	Q(P) Curve Function	Enable Q(P) Curve when it is required by local grid standards and requirements.
2	Mode Selection	Set Q(P) curve mode, supporting basic mode and slope mode.
3	Pn-point Power	The percentage of the output reactive power to the rated power at Pn point, n=1, 2, 3, 4, 5, 6. For example, setting to 90 means $Q/P_{rated}\%=90\%$ .
4	Pn-point Reactive Power	The percentage of the output active power to the rated power at Pn point, n=1, 2, 3, 4, 5, 6. For example, When set to 90, it means: $P/P_{rated}\% = 90\%$ .
5	Over-excitation Slope	When the Q(P) curve mode is set to slope mode, configure the power variation slope as either a positive or negative value.

No.	Parameters	Description
6	Under-excitation Slope	
7	Pn-point Power	Ratio of reactive power to rated power at Pn points (n=1, 2, 3). For example, setting to 90 means $Q/P_{rated}\%=90\%$ .
8	Pn-point Reactive Power	Ratio of active power to rated power at Pn points (n=1, 2, 3). For example, When set to 90, it means: $P/P_{rated}\% = 90\%$ .
9	Time Constant	The reactive power must reach 95% of the target value within 3 time constants, following a first-order low-pass filter curve.

### 9.3.8.2 Setting the Active Power Mode

**Step 1:** Tap **Home > Settings > Advanced Settings > Safety Parameter Settings > Active Power Mode Settings** to set the parameters.

**Step 2:** Set the parameters based on actual needs.

#### P(F) Curve

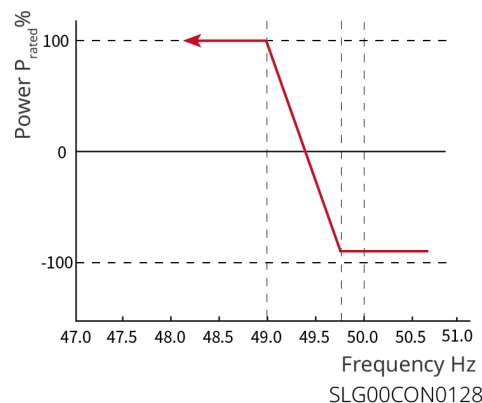
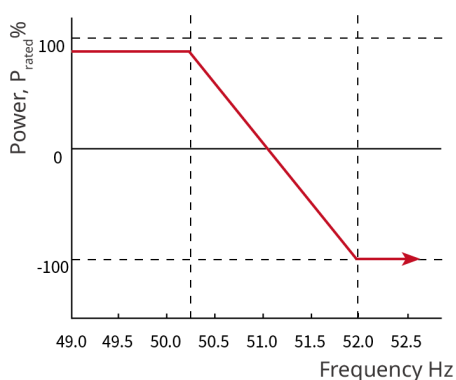

#### P(U) Curve



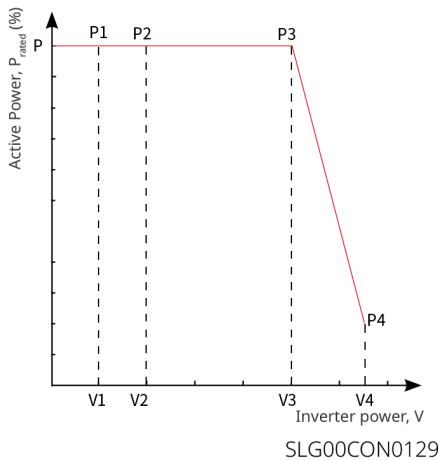

No.	Parameter s	Explanation
1	Generation Power Limit	Set the change slope when the active output power increases or decreases.
2	Power Gradient	Set the active power change slope.
Overfrequency Unloading		
1	P(F) Curve	Enable P(F) Curve when it is required by local grid standards and requirements.
2	Over-Frequency Load Shedding Mode	Set the overfrequency unloading mode based on actual needs. <ul style="list-style-type: none"> <li>• Slope mode: adjusts power based on the over frequency point and load reduction slope.</li> <li>• Stop mode: adjusts the power based on the over-frequency start point and over-frequency end point.</li> </ul>
3	Overfrequency Threshold	The inverter output active power will decrease when the utility grid frequency is too high. The inverter output power will decrease when the utility grid frequency is higher than <b>Overfrequency Threshold</b> .

No.	Parameters	Explanation
4	Import/Export Electricity Conversion Frequency	When the set frequency value is reached, the system switches from selling electricity to buying electricity.
5	Overfrequency Endpoint	The inverter output active power will decrease when the utility grid frequency is too high. The inverter output power will stop decreasing when the utility grid frequency is higher than <b>Overfrequency Endpoint</b> .
6	Over-Frequency Power Slope Reference Power	Adjust the inverter output power based on Apparent Active Power, Rated Active Power, Momentary Active Power, Or Max. Active Power.
7	Power response to overfrequency gradient	The inverter output active power will increase when the utility grid frequency is too high. Indicates the slope when the inverter output power decreases.
8	Intentional Delay $T_a$	Indicates the delayed response time when the inverter output power is higher than the <b>Overfrequency Threshold</b> .
9	Hysteretic Function	Enable the hysteretic function.
10	Frequency Hysteresis Point	During over-frequency load reduction, if the frequency decreases, the power output is based on the lowest point of the load reduction power until the frequency is less than the hysteresis point and the power is restored.
11	Hysteresis Waiting Time	For over-frequency load reduction and frequency decrease, when the frequency is less than the hysteresis point, the power recovery waiting time, that is, it takes a certain amount of time to recover the power.

No.	Parameters	Explanation
12	Hysteresis Power Recovery Slope Reference Power	For over-frequency load reduction and frequency decrease, when the frequency is less than the hysteresis point, the power recovery benchmark, that is, the power recovery is based on the recovery slope * the rate of change of the reference power. Support: P <sub>n</sub> rated power, P <sub>s</sub> apparent power, P <sub>m</sub> current power, P <sub>max</sub> maximum power, power difference ( $\Delta P$ ).
13	Hysteretic Power Recovery Slope	For over-frequency load reduction and frequency reduction, when the frequency is less than the hysteresis point, the power change slope when the power is restored.
Underfrequency Loading		
1	P(F) Curve	Enable P(F) Curve when it is required by local grid standards and requirements.
2	Underfrequency Load Mode	Set the underfrequency unloading mode based on actual needs. <ul style="list-style-type: none"> <li>• Slope mode: adjusts power based on the underfrequency point and load increase slope.</li> <li>• Stop mode: adjusts the power based on the underfrequency start point and underfrequency end point.</li> </ul>
3	Underfrequency Threshold	The inverter output active power will increase when the utility grid frequency is too low. The inverter output power will increase when the utility grid frequency is lower than <b>Underfrequency Threshold</b> .
4	Import/Export Electricity Conversion Frequency	When the set frequency value is reached, the system switches from selling electricity to buying electricity.

No.	Parameters	Explanation
5	Underfrequency Endpoint	The inverter output active power will increase when the utility grid frequency is too low. The inverter output power will stop increasing when the utility grid frequency is lower than <b>Underfrequency Endpoint</b> .
6	Over-Frequency Power Slope Reference Power	Adjust the inverter output power based on Apparent Active Power, Rated Active Power, Momentary Active Power, Or Max. Active Power.
7	Under-Frequency Power Slope	The inverter output active power will increase when the utility grid frequency is too low. The slope of the inverter output power when it rises.
8	Tentional Delay $T_a$	Indicates the delayed response time when the inverter output power is lower than the <b>Underfrequency Threshold</b> .
9	Hysteretic Function	Enable the hysteretic function.
10	Frequency Hysteresis Point	During underfrequency loading, if the frequency increases, the power is output according to the lowest point of the loaded power until the frequency is higher than the hysteresis point and the power is restored.
11	Hysteresis Waiting Time	For underfrequency loading, the frequency increases, when the frequency is higher than the hysteresis point, the waiting time for power recovery, that is, it takes a certain amount of time to recover the power.

No.	Parameters	Explanation
12	Hysteresis Power Recovery Slope Reference Power	For underfrequency loading, the frequency increases, when the frequency is higher than the hysteresis point, the benchmark for power recovery, that is, the power recovery is carried out according to the recovery slope * the rate of change of the benchmark power. Support: P <sub>n</sub> rated power, P <sub>s</sub> apparent power, P <sub>m</sub> current power, P <sub>max</sub> maximum power, power difference ( $\Delta P$ ).
13	Hysteretic Power Recovery Slope	For under-frequency loading, frequency increase, when the frequency is higher than the hysteresis point, the power change slope when power is restored.
14	P(U) Curve	Enable P(U) Curve when it is required by local grid standards and requirements.
15	V <sub>n</sub> Voltage	The percentage of actual voltage to the rated voltage at V <sub>n</sub> point, n= 1, 2, 3, 4. For example, setting V <sub>n</sub> Voltage to 90 means V/V <sub>rated</sub> %=90%.
16	V <sub>n</sub> Active Power	The percentage of the output active power to the apparent power at V <sub>n</sub> point, (n= 1, 2, 3, 4). For example, setting <b>V<sub>n</sub> Reactive Power</b> to 48.5 means P/P <sub>rated</sub> %=48.5%.
17	Output Response Mode	Set the active power output response mode. Supports: <ul style="list-style-type: none"> <li>• PT-1 Behavior, realize active scheduling based on the first-order LPF curve within the response time constant.</li> <li>• Gradient Control, realize active scheduling based on the power change slope.</li> </ul>
18	Power Gradient	When the output response mode is set to Gradient Control, active power scheduling is achieved according to the power change gradient.

No.	Parameters	Explanation
19	First-order Low-pass Filter Time Parameter	Set the time constant within which the active power changes based on the first order LPF curve when the Output Response Mode is set to be First-order Low-pass Filter Time Parameter.
20	Overload Function Switch	When enabled, the maximum active power output is 1.1 times the rated power; otherwise, the maximum active power output is consistent with the rated power value.

### 9.3.8.3 Setting Protection Parameters

**Step 1 :** Tap **Home > Settings > Advanced Settings > Safety Parameter Settings > Protection Parameters** to set the parameters.

**Step 2:** Set the parameters based on actual needs.

No.	Parameters	Description
1	OV Stage n Trip Value	Set the grid overvoltage protection threshold value, n=1,2,3,4.
2	OV Stage n Trip Time	Set the grid overvoltage protection tripping time, n=1,2,3,4.
3	UV Stage n Trip Value	Set the grid undervoltage protection threshold value, n=1,2,3,4.
4	UV Stage n Trip Time	Set the grid undervoltage protection tripping time.
5	10min Overvoltage Trip Threshold	Set the 10min overvoltage protection threshold value.
6	10min Overvoltage Trip Time	Set the 10min overvoltage protection tripping time.
7	OF Stage n Trip Value	Set the grid overfrequency triggering n-th order protection point, n=1,2,3,4.
8	OF Stage n Trip Time	Set the grid overfrequency trigger n-th order trip time, n=1,2,3,4.

No.	Parameters	Description
9	UF Stage n Trip Value	Set the grid underfrequency triggering n-th order protection point, n=1,2,3,4.
10	UF Stage n Trip Time	Set the grid underfrequency trigger n-th order trip time, n=1,2,3,4.

### 9.3.8.4 Setting Connection Parameters

**Step 1 :** Tap **Home > Settings > Advanced Settings > Safety Parameter Settings > Protection Parameters** to set the parameters.

**Step 2:** Set the parameters based on actual needs.

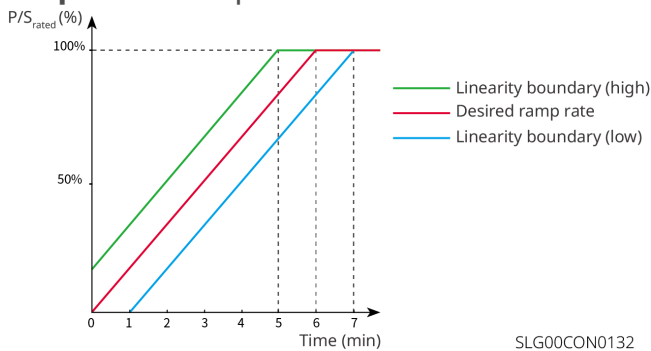

No.	Parameters	Description
Ramp Up		
1	Upper Voltage	The inverter cannot connect to the grid if it is powered on for the first connection and the grid voltage is higher than the <b>Upper Voltage</b> .
2	Lower Voltage	The inverter cannot connect to the grid if it is powered on for the first connection and the grid voltage is lower than the <b>Lower Voltage</b> .
3	Upper Frequency	The inverter cannot connect to the grid if it is powered on for the first connection and the grid frequency is higher than the <b>Upper Frequency</b> .

No.	Parameters	Description
4	Lower Frequency	The inverter cannot connect to the grid if it is powered on for the first connection and the grid frequency is lower than the <b>Lower Frequency</b> .
5	Observation Time	The waiting time for connecting the inverter to the grid when meeting the following requirements. 1. The inverter is powered on for the first connection. 2. The utility grid voltage and frequency meet certain requirements.
6	Soft Ramp Up Gradient	Enable the start up power slope.
7	Soft Ramp Up Gradient	Indicates the percentage of incremental output power per minute based on the local requirements when the inverter is powered on for the first time.
Reconnection		
8	Upper Voltage	The inverter cannot connect to the grid if it is reconnecting due to a fault and the grid voltage is higher than the <b>Upper Voltage</b> .
9	Lower Voltage	The inverter cannot connect to the grid if it is reconnecting due to a fault and the grid voltage is lower than the <b>Lower Voltage</b> .
10	Upper Frequency	The inverter cannot connect to the grid if it is reconnecting due to a fault and the grid frequency is higher than the <b>Upper Frequency</b> .
11	Lower Frequency	The inverter cannot connect to the grid if it is reconnecting due to a fault and the grid frequency is lower than the <b>Lower Frequency</b> .
12	Observation Time	The waiting time for connecting the inverter to the grid when meeting the following requirements. 1. The inverter is reconnecting to the grid due to a fault. 2. The utility grid voltage and frequency meet certain requirements.
13	Reconnection Gradient	Enable the start up power slope.



No.	Parameters	Description
14	Reconnection Gradient	Indicates the percentage of incremental output power per minute based on the local requirements when the inverter is powered on for the first time. For example, setting Reconnection Gradient to 10 means the reconnect slope is 10%P/Srated/min.

### 9.3.8.5 Setting Voltage Ride Through Parameters

**Step 1 :** Tap **Home > Settings > Advanced Settings > Safety Parameter Settings > Voltage Ride Through** to set the parameters.

**Step 2 :** Set the parameters based on actual needs.

No.	Parameters	Description
LVRT		
1	UVn Voltage	The ratio of the ride through voltage to the rated voltage at UVn point during LVRT. n=1,2,3,4,5,6,7.
2	UVn Time	The ride through time at UVn point during LVRT. n=1,2,3,4,5,6,7
3	Enter Into LVRT Threshold	The inverter will not be disconnected from the utility grid immediately when the grid voltage is between Enter Into LVRT Threshold and Exit LVRT Endpoint.
4	Exit LVRT Endpoint	
5	Slope K2	K-factor for reactive power during LVRT.
6	Zero Current Mode	The system outputs zero current during LVRT.
7	Entry Threshold	Set the entry threshold of zero current mode.
HVRT		

No.	Parameters	Description
1	OVn Voltage	The ratio of the ride through voltage to the rated voltage at OVn point during HVRT. n=1,2,3,4,5,6,7.
2	OVn Time	The ride through time at OVn point during HVRT. n=1,2,3,4,5,6,7.
3	Enter High Crossing Threshold	The inverter will not be disconnected from the utility grid immediately when the grid voltage is between Enter High Crossing Threshold and Exit High Crossing Threshold.
4	Exit High Crossing Threshold	
5	Slope K2	K-factor for reactive power during HVRT.
6	Zero Current Mode	The system outputs zero current during HVRT.
7	Entry Threshold	Set the entry threshold of zero current mode.

### 9.3.8.6 Setting Frequency Ride Through Parameters

**Step 1 :** Tap **Home > Settings > Advanced Settings > Safety Parameter Settings > Frequency Ride Through** to set the parameters.

**Step 2 :** Set the parameters based on actual needs.

No.	Parameters	Description
1	UFn Frequency	The frequency at the UFn point during frequency ride through.
2	UFn Frequency	The frequency at the UFn point during frequency ride through. n=1,2,3.
3	UFn Time	The ride through duration at the UFn point during frequency ride through. n=1,2,3.

No.	Parameters	Description
4	OFn Frequency	The frequency at the OFn point during frequency ride through. n=1,2,3。
5	OFn Time	The ride through duration at the OFn point during frequency ride through. n=1,2,3。

## 9.3.9 Setting Generator/Load Control

### 9.3.9.1 Setting Load Control

#### NOTICE

- Loads and generators can be controlled by SolarGo app when the inverter supports load control function.
- For ET40-50kW series inverters, the load control function is supported only when the inverter is used with STS. The inverter supports load control of the GENERATOR port or the BACKUP LOAD port.

**Step 1:** Tap **Home > Settings > Port Connection** to set the parameters.

**Step 2:** Select **Generator Control** or **Load Control** based on actual needs.

- Dry Contact Mode: when the switch is ON, the loads will be powered; when the switch is OFF, the power will be cut off. Turn on or off the switch based on actual needs.

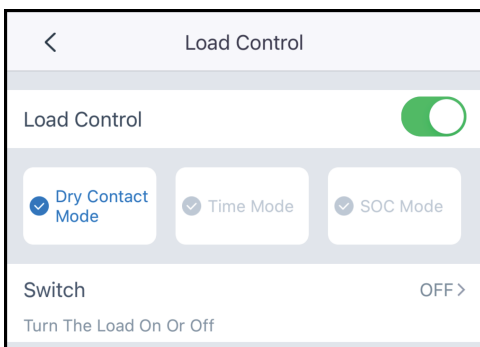

- Time Mode: set the time to enable the load, and the load will be powered automatically within the setting time period. Select standard mode or intelligent mode.

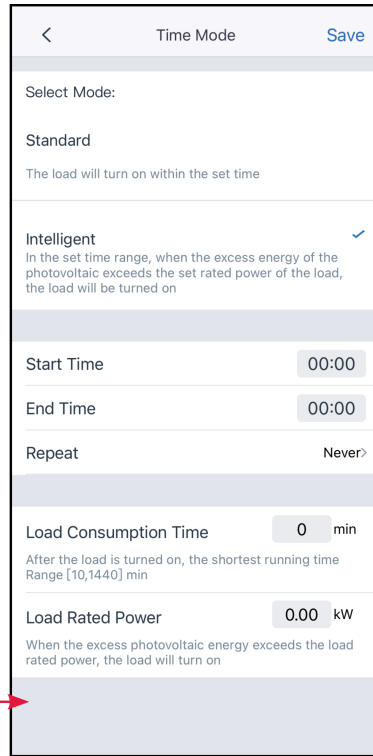
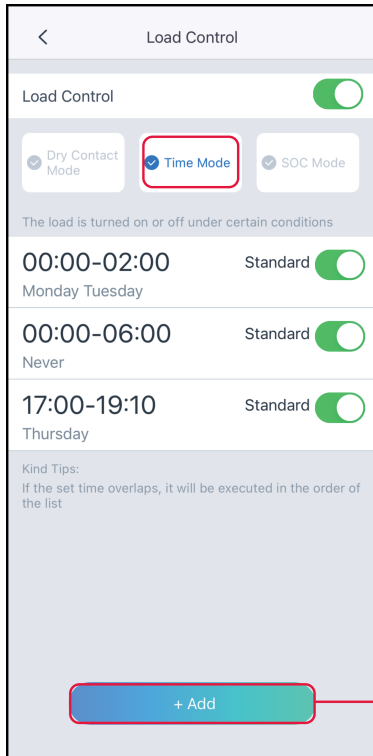

No.	Parameters	Description
1	Standard	The loads will be powered within the setting time period.
2	Intelligent	Once the excess energy of the photovoltaic exceeds the load nominal power within the time period, the loads will be powered.
3	Start Time	The time mode will be on between the Start Time and End Time.
4	End Time	
5	Repeat	The repeat days.
6	Load Consumption Time	The shortest load working time after the loads been powered. The time is set to prevent the loads be turned on and off frequently when the PV power fluctuates greatly. Only for Intelligent mode.

No.	Parameters	Description
7	Load Rated Power	The loads will be powered when the excess energy of the photovoltaic exceeds the nominal power of load. Only for Intelligent mode.

- SOC Mode: the inverter has integrated dry contact controlling port, which can control whether the load is powered or not by contactor. In off-grid mode, the load connected to the port will not be powered if the BACKUP overload is detected or the battery SOC value is lower than the Off-grid battery protection value. Set Off-grid Battery Protection Value based on actual needs.

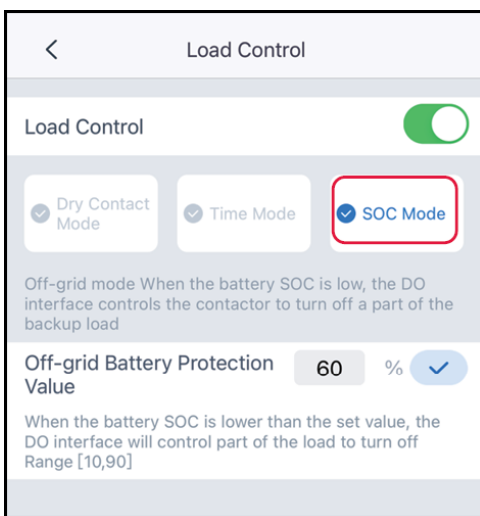

### 9.3.9.2 Setting the Generator Parameters

#### NOTICE

- When the inverter supports the generator control function, the generator can be controlled through the SolarGo App.
- For ET40-50kW series inverters, the generator can be connected and controlled only when the inverter is used with STS.

**Step 1 :** Tap **Home > Settings > Port Connection** to set the parameters.

**Step 2:** Select Generator Connection or Load Connection based on actual needs.

**Step 3 :** When setting the generator control function, select the generator type according to the actual access situation. Currently supported:**Not Installed, Manual**

**Control Of Generator or Automatic Control Generator.** And set the parameters according to the selected generator type.

- Not Installed: If no generator is connected in the system, select Not Installed.
- Manual Control Of Generator(Doesn't Support Dry Node Connection): Start or stop the generator manually. The inverter cannot control the generator when Manual Control Of Generator(Doesn't Support Dry Node Connection) is selected.
- Automatic control generator (Supports dry node connection): If the generator has dry contact port and is connected to the inverter, set the generator control mode to Switch Control Mode or Automatic Control Mode based on actual needs.
  - Switch Control Mode: The generator will start working when the Generator Dry Node Switch is on, and stop automatically after reaching Run Time.
  - Automatic Control Mode: The generator will work during Run Time, but stop working during Prohibited Working Hours.

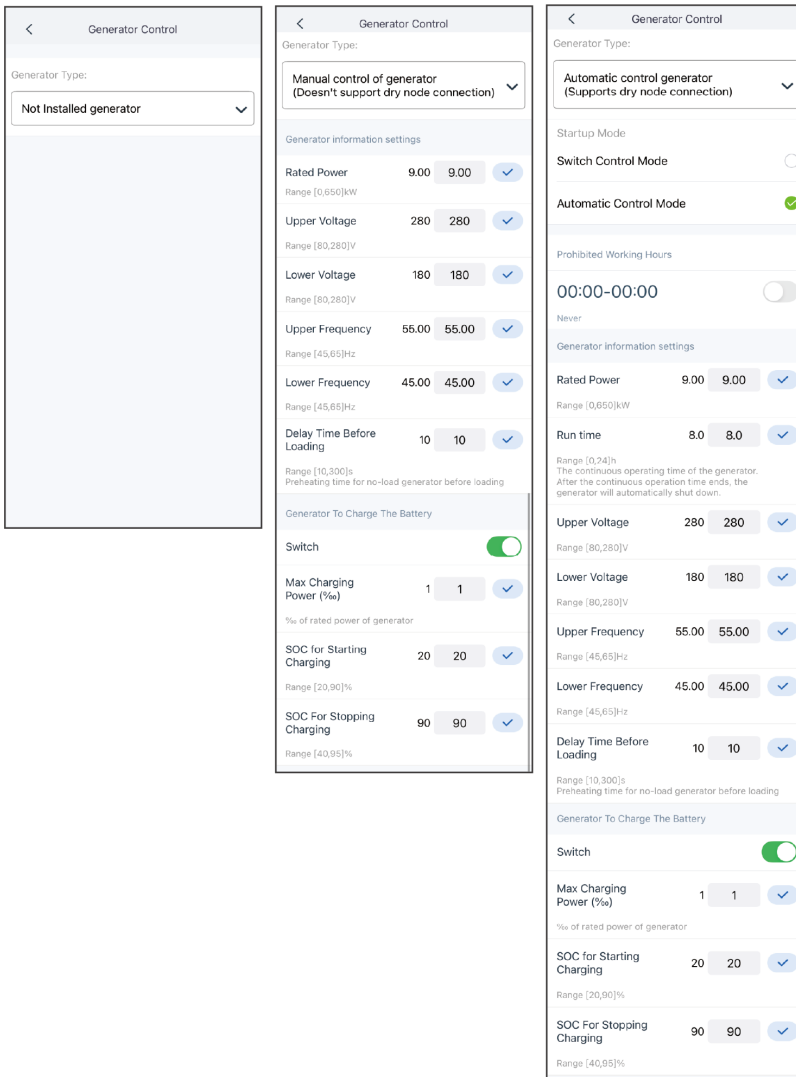

SLG00CON0079

No.	Parameters	Description
1	Startup Mode	Switch Control Mode/Automatic Control Mode
Switch Control Mode		
2	Generator Dry Node Switch	Only for Switch Control Mode.
3	Run Time	Set the generator's continuous runtime, after which the generator will be turned off.
Automatic Control Mode		
4	Prohibited Working Hours	Set the time period during which the generator cannot work.
5	Run Time	Set the generator's continuous runtime, after which the generator will be turned off. If the generator start-up operation time includes prohibited working time, the generator will stop running during this time period; after the prohibited working time, the generator will restart running and timing.

No.	Parameters	Description
Generator Information Settings		
1	Rated Power	Set the rated power of the generator.
2	Run Time	Set the continuous running time of the generator. The generator will be shut down after the continuous running time ends.
3	Upper Voltage	Set the operation voltage range of the generator.
4	Lower Voltage	
5	Frequency Cap	Set the operation frequency range of the generator.
6	Lower Frequency	
7	Preheating time	Set the generator no-load preheating time.
Parameter settings for generator charging batteries		

No.	Parameters	Description
8	Switch	Select whether to use the generator to generate electricity to charge the battery.
9	Max.charging power (%)	The charging power when the generator generates electricity to charge the battery.
10	Start charging SOC	When the battery SOC is lower than this value, the generator generates electricity to charge the battery.
11	Stop charging SOC	When the battery SOC is higher than this value, stop charging the battery.

### 9.3.9.3 Setting Microgrid Parameters

#### NOTICE

When the inverter supports microgrid function, you can set microgrid parameters through SolarGo App.

**Step 1** : Tap **Home > Settings > Port Connection** to set the parameters.

**Step 2** : According to the actual interface prompts, enter the microgrid control interface and set the microgrid parameters according to actual needs.



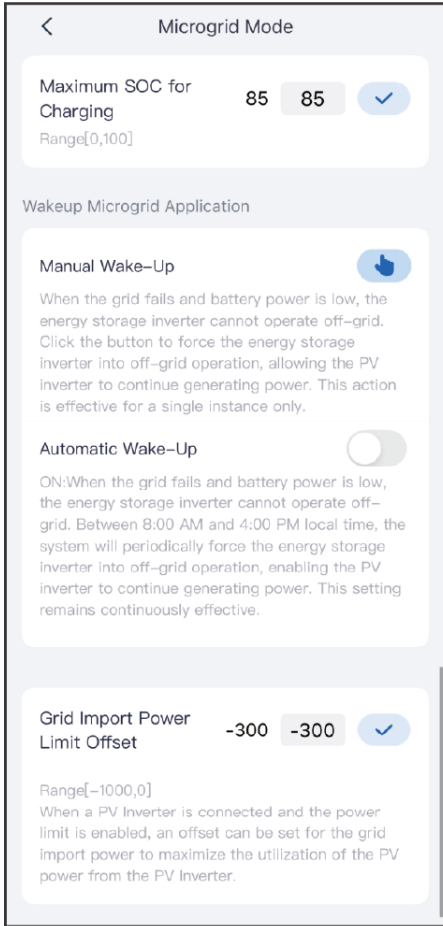

SLG00CON0078

No.	Parameters	Description
1	Maximum SOC for Charging	Set the upper limit of charging SOC, and stop charging when the upper limit is reached.
2	Manual wake-up	<ul style="list-style-type: none"> <li>When the grid fails, if the battery power is low, the energy storage inverter cannot be supported to work off the grid. Click this button to force the energy storage inverter to output voltage to the grid-connected inverter, thereby starting the grid-connected inverter.</li> <li>Single effect.</li> </ul>

No.	Parameters	Description
3	Automatic wake-up	<ul style="list-style-type: none"> <li>When the grid fails, if the battery power is low, the energy storage inverter cannot be supported to work off the grid. After enabling this function, the system will force the energy storage inverter to output voltage to the grid-connected inverter at a fixed time, thereby starting the grid-connected inverter.</li> <li>Multiple effect.</li> </ul>
4	Grid Import Power Limit Offset	Set the adjustable range of the maximum power that the device can actually buy from the grid.

### 9.3.10 Setting the Meter Parameters

#### 9.3.10.1 Meter/CT-Assisted Test

Meter/CT-Assisted Test is used to auto-check if the Smart Meter and CT are connected in the right way and their working status.

**Step 1** : Tap **Home** > **Settings** > **Meter/CT Assisted Test** to set the function.

**Step 2** : Tap **Start Test** to start test. Check Test Result after test.

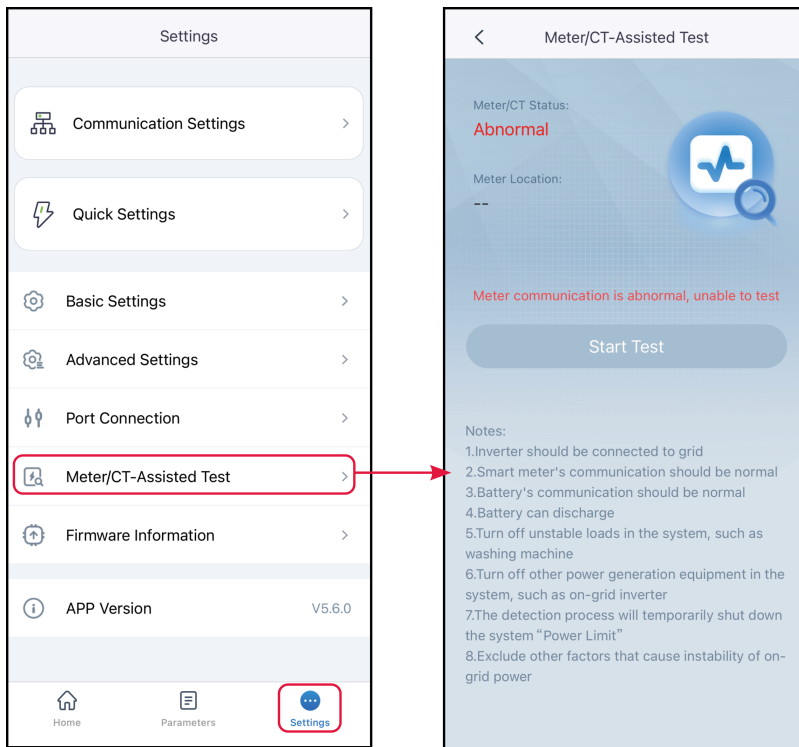

## 9.3.11 Equipment Maintenance

### 9.3.11.1 Checking Firmware Information/Upgrading Firmware Version

Upgrade the DSP version, ARM version, BMS version, AFCI version, or STS version of the inverter, or firmware version of the communication module. Some devices do not support upgrading the firmware version through SolarGo app.

#### NOTICE

If the Firmware Upgrade dialog box pops up once logging into the app, click Firmware Upgrade to directly go to the firmware information page.

#### 9.3.11.1.1 Regular Upgrade

## NOTICE

- When there is a red dot on the right side of the firmware information, please click to view the firmware update information.
- During the upgrade process, please ensure that the network is stable and the device is connected to SolarGo, otherwise the upgrade may fail.

**Step 1 :** Tap **Home > Settings > Firmware Information** to check the firmware version. If the firmware upgrade dialog box pops up, tap **Firmware Upgrade** and turn to the upgrade interface.

**Step 2 :** (Optional) Tap **Check For Update** to confirm whether the latest firmware version is available for updating.

**Step 3:** Tap **Firmware Upgrade** to enter the firmware upgrade interface.

**Step 4 :** (Optional) Tap **Learn More** to view firmware-related information, such as the current version, the latest version, firmware update records, etc.

**Step 5 :** Tap **Upgrade** and complete the upgrade according to the prompts on the interface.

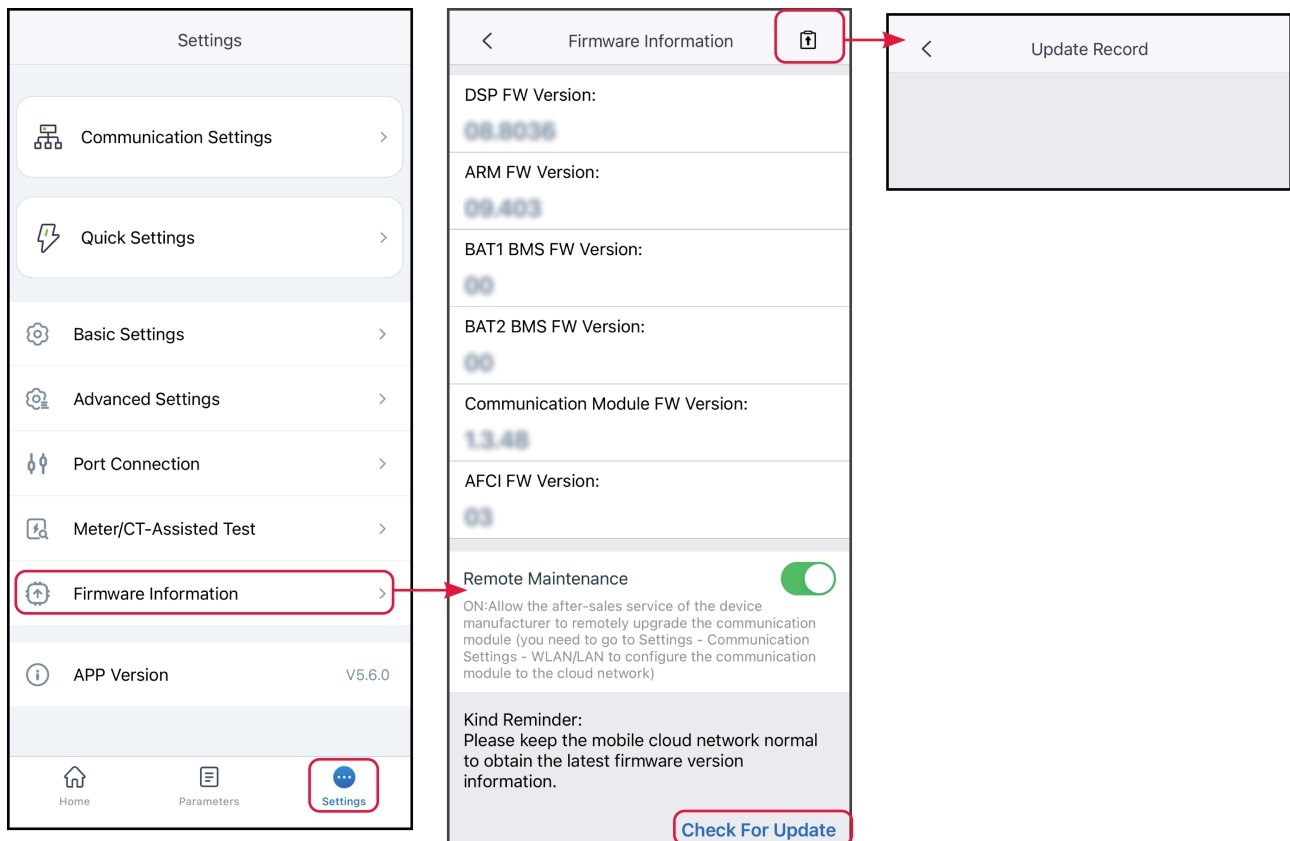

### 9.3.11.1.2 One-click Upgrade

**NOTICE**

- When there is a red dot on the right side of the firmware information, please click to view the firmware update information.
- During the upgrade process, please ensure that the network is stable and the device is connected to SolarGo, otherwise the upgrade may fail.

**Step 1 :** Tap **Home > Settings > Firmware Information**. Tap **Firmware Information** as prompted to enter the firmware upgrade page.

**Step 2 :** Tap **Upgrade** and follow the prompts to complete the upgrading. If you only need to upgrade a specific firmware version, tap **Learn More** to check the firmware related information and tap **Firmware Upgrade** below the firmware version you want to upgrade, and follow the on-screen prompts to complete the operation.

**Step 3 :** Tap **Learn More** to view all current firmware version information.

**Step 4: (Optional)** Tap  ,to view the version upgrade record.

SLG00CON0127

### 9.3.11.1.3 Automatic Upgrade

## NOTICE

- When using WiFi/LAN Kit-20 or WiFi Kit-20 module communication and the module firmware version is V2.0.1 or above, the device automatic upgrade function can be enabled.
- After the device automatic upgrade function is enabled, if the module version is updated and the device has been connected to the network, the corresponding firmware version can be automatically upgraded.

**Step 1 :** Tap **Home > Settings > Firmware Information.**

**Step 2 :** Enable or disable the automatic device upgrade function according to actual needs.

### 9.3.11.2 Change the Login Password

## NOTICE

The login password can be changed. Keep the changed password in mind after changing it. Contact the after-sales service if you forget the password.

**Step 1 :** Tap **Home > Settings > Change Login Password** to change the password.

**Step 2 :** Change the password based on actual needs.

< Change Login Password Save

Please enter the new password 

Please enter new password again 

Note: 8-16 characters, need a combination of numbers and uppercase or lowercase letters (0-9, a-z, A-Z)

SLG00CON0088

# 10 Power Plant Monitoring

## 10.1 SEMS+

### 10.1.1 Product Introduction

SEMS+ App is a monitoring platform to manage power plants and devices, and check the operating data and alarming information of the power plant.

#### 10.1.1.1 Applicable Product Model

SEMS+ App can be used to monitor and manage GoodWe products, such as inverters, smart meters, smart loggers,chargers, batteries and so on.

#### 10.1.1.2 Downloading and Installing the App

**Make sure that the mobile phone meets the following requirements:**

- Operating system: Android 6.0 or later, iOS 13.0 or later.
- Internet connection via browser.
- WLAN/Bluetooth capabilities.

#### Download Methods:

##### Method I

Search SEMS+ on Google Play (Android) or App Store (iOS) to download and install the App.

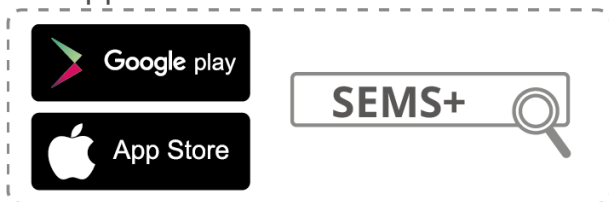

SEMS0001

##### Method II

Scan the QR code below to download and install the App.





### 10.1.1.3 App Connection

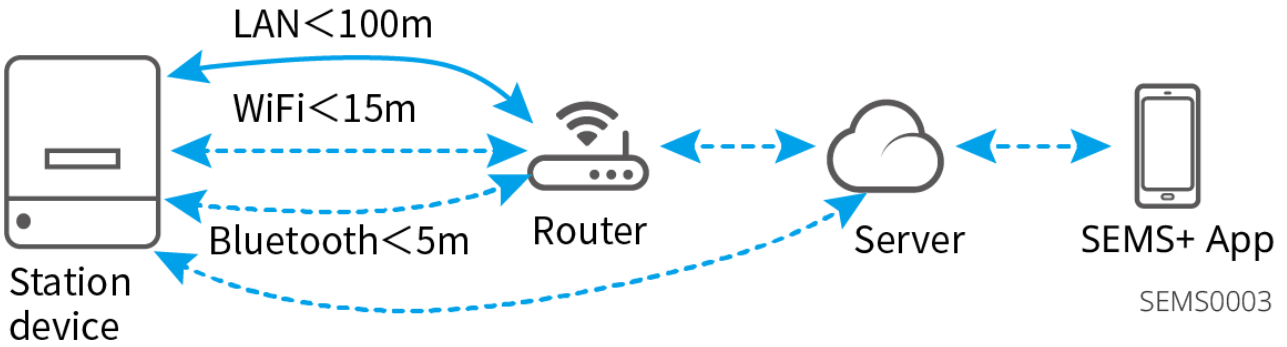

### 10.1.1.4 Setting Language and Server

<b>NOTICE</b>
The server is automatically matched based on login account information. To set it manually, ensure that the selected region matches the region of the account. Otherwise, login may fail.

Select the language and the server based on the actual situation.

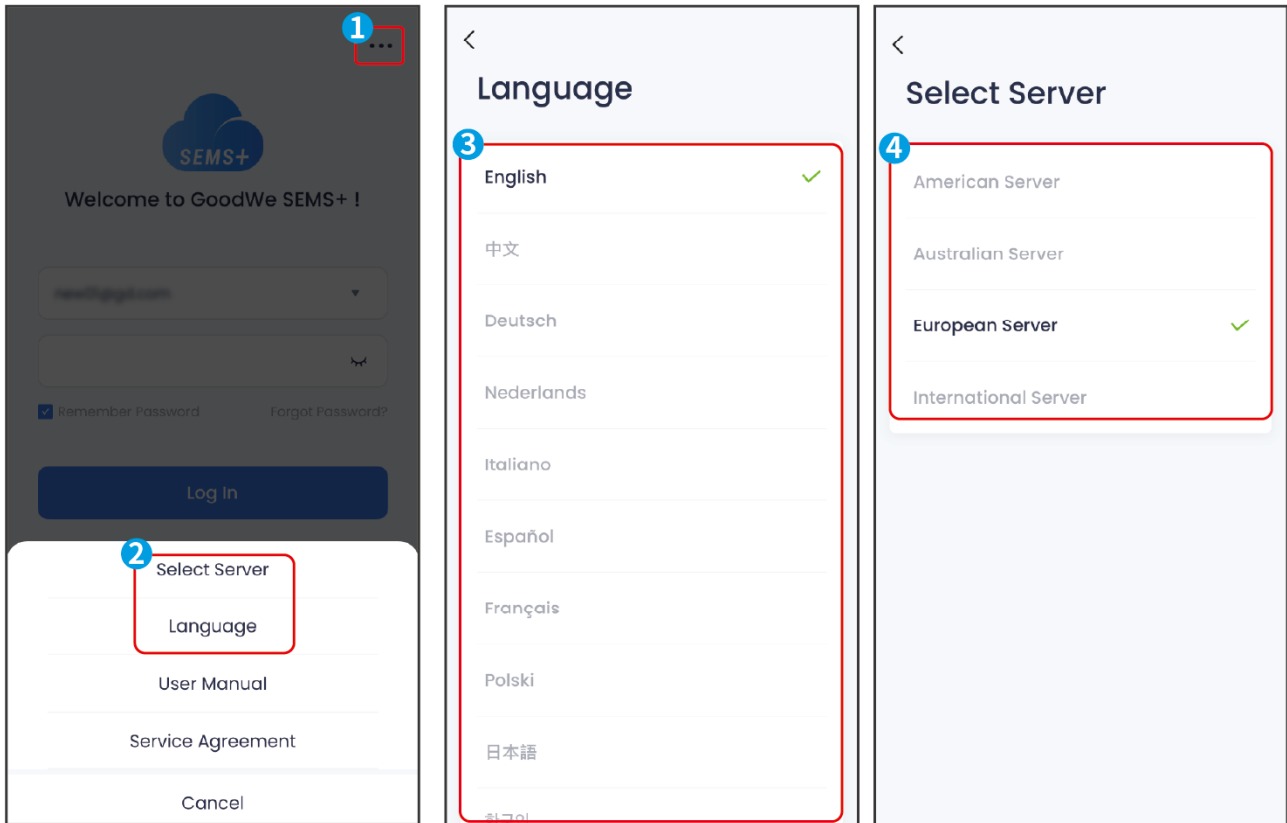

### 10.1.1.5 Setting the Network Information

The SEMS+ App allows connecting devices via Bluetooth or WiFi and configuring network parameters to realize remote monitoring or management.

#### NOTICE

The device name varies depending on the inverter model or smart dongle model.

- Wi-Fi/LAN Kit, Wi-Fi Kit, Wi-Fi Box: Solar-WiFi\*\*\*
- WiFi/LAN Kit-20: WLA-\*\*\*
- WiFi Kit-20: WFA-\*\*\*
- Ezlink3000: CCM-BLE\*\*\*, CCM-\*\*\*, \*\*\*
- 4G Kit-CN-G20/4G Kit-CN-G21: GSA-\*\*\*; GSB-\*\*\*
- AC Charger:\*\*\*

### 10.1.2 Managing the Account

### 10.1.2.1 Registering an Account

**Step 1:** Tap **Register** to enter the account registration interface.

**Step 2:** Select the account type based on your actual needs and tap **Next**.

**Step 3:** Enter your account information based on the actual situation and tap **Register** to complete the registration.

SEMS0005

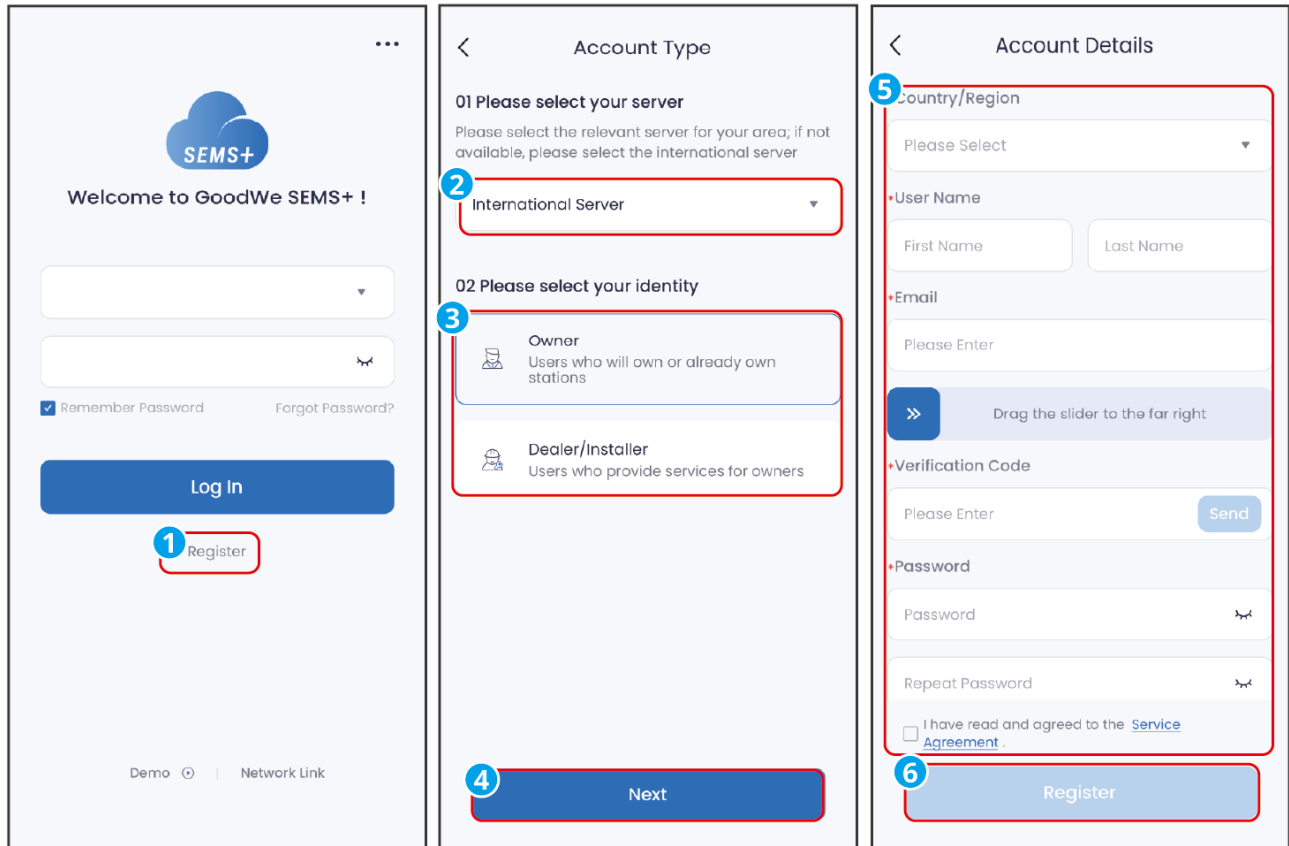

### 10.1.2.2 Logging in to the App

#### NOTICE

- Register an account or obtain an account from your dealer before logging in.
- Check and manage power station after logging in. The actual interface takes precedence.

**Step 1:** Enter the username and password, read, and agree to the login agreement. Tap **Log In**.

SEMS0006

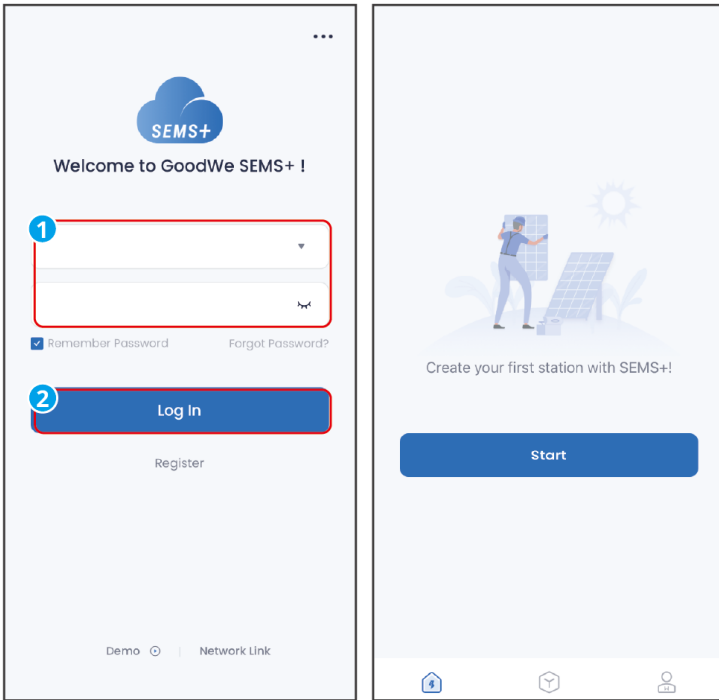

### 10.1.2.3 Switching Accounts

**Step 1:** Go to **My** tab, and tap **Log Out** > **Log with Another Account**.

**Step 2:** Select an already added account or add a new account based on actual needs.

SEMS0007

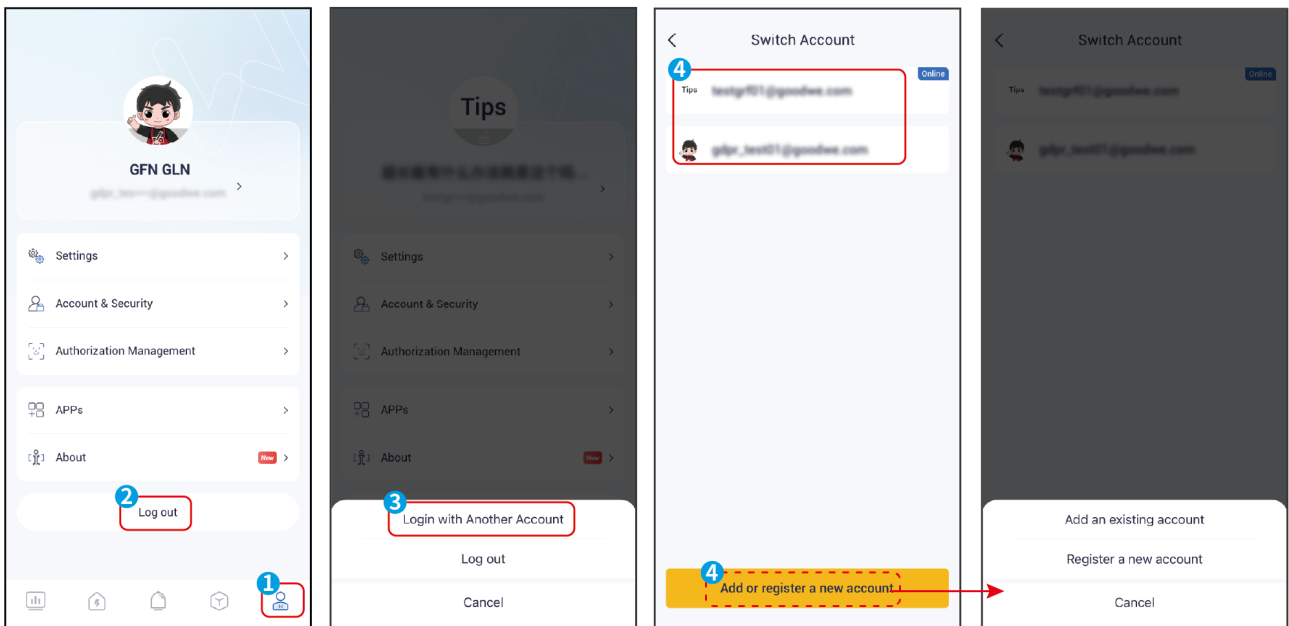

### 10.1.2.4 Deleting an Account

**Step 1:** Go to **My** tab and tap **Account&Security**.

**Step 2:** Tap **Close Account**, input the account password, and **Submit**.

SEMS0008

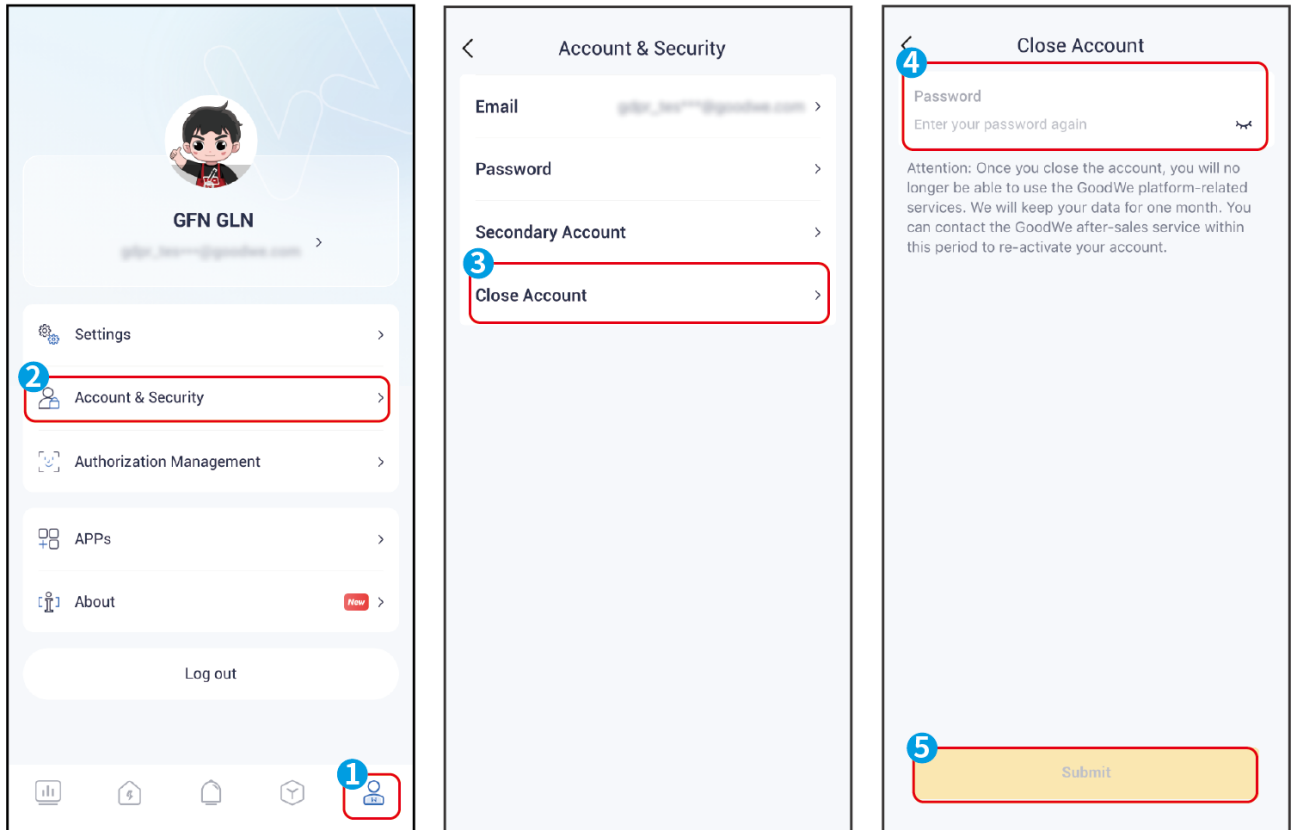

### 10.1.2.5 Account Permission Descriptions

The SEMS+ App supports various types of accounts with different permissions. Refer to the table below for details.

Primary menu	Submenu	Third-Level Menu	Fourth-Level Menu	Fifth-Level Menu	Permissions
Login & Register	-	-	-	-	Administrator, Technician, Browser, End User, Visitor
Overview	Monitoring Information	-	-	-	Administrator, Technician, Browser, End User, Visitor
	Create Station	-	-	-	Administrator,

					Technician, End User and Visitor		
Station	Station List	-	-	-	Administrator, Technician, Browser, End User, Visitor		
	Station Details	Monitoring	-	-	Administrator, Technician, Browser, End User, Visitor		
		Device	Add Device	-	-	Administrator, Technician, End User	
			Device List	Search Device	-	-	Administrator, Technician, Browser, End User, Visitor
				Replace Device	-	-	Administrator, Technician, End User
				Edit Device	-	-	Administrator, Technician, End User
				Delete Device	-	-	Administrator, Technician, End User
			Device Details	Device Monitoring Info	-	-	Administrator, Technician, Browser, End User, Visitor
				Device Remote Control	-	-	Administrator, Technician, End User
				Device Remote Upgrade	-	-	Administrator, Technician
			Alarms	-	-	-	Administrator, Technician, Browser, End User, Visitor
			Station Configuration	Edit Station	-	-	Administrator, Technician, End User
		Delete		-	-	Administrator,	

			Station		Technician, End User
			Replacement History	-	Administrator, Technician, Browser, End User
			User Information	-	Administrator, Technician, End User
			Home Configuration	-	Administrator, Technician, Browser, End User, Visitor
	Create Station	-	-	-	Administrator, Technician, End User and Visitor
Alarm	-	-	-	-	Administrator, Technician, Browser
Services	Services	Warranty	-	-	Administrator, Technician, Browser, End User, Visitor
		Report Center	-	-	Administrator, Technician, Browser, End User
		GoodWe News	-	-	Administrator, Technician, Browser, End User, Visitor
		Announcements	-	-	Administrator, Technician, Browser, End User, Visitor
		Community	-	-	Administrator, Technician, Browser, End User, Visitor
	Tools	Create Station	-	-	Administrator, Technician, End User and Visitor
		Network Link	-	-	Administrator, Technician, Browser,

					End User, Visitor	
		DNSP	-	-	Administrator, Technician, Browser, End User, Visitor	
	Help	-	-	-	Administrator, Technician, Browser, End User, Visitor	
My	User Profile	-	-	-	Administrator, Technician, Browser, End User, Visitor	
	User Information	-	-	-	Administrator, Technician, Browser, End User, Visitor	
	Setting	-	-	-	Administrator, Technician, Browser, End User, Visitor	
	Account Security	Email	-	-	-	Administrator, Technician, Browser, End User, Visitor
		Password	-	-	-	Administrator, Technician, Browser, End User, Visitor
		Secondary Account	-	-	-	Administrator, Technician, Browser
		Close Account	-	-	-	Administrator, Technician, Browser, End User, Visitor
	Auth Management	Remote Control Auth	-	-	-	Administrator, Technician, Browser, End User, Visitor
		Monitoring Auth	-	-	-	End User
	Apps	-	-	-	Administrator, Technician, Browser,	



					End User, Visitor
	About	-	-	-	Administrator, Technician, Browser, End User, Visitor
	Logout	Logout	-	-	Administrator, Technician, Browser, End User, Visitor
		Login anther Account	-	-	Administrator, Technician, Browser, End User, Visitor

### 10.1.3 Checking Station Information

#### 10.1.3.1 Checking Overview Information of All Stations

After logging in, you can view an overview of all stations linked to your account from the homepage.

Or sort the list of all power stations through different sorting and filtering conditions on the power station page to view the detailed information of the power stations.

SEMS0018

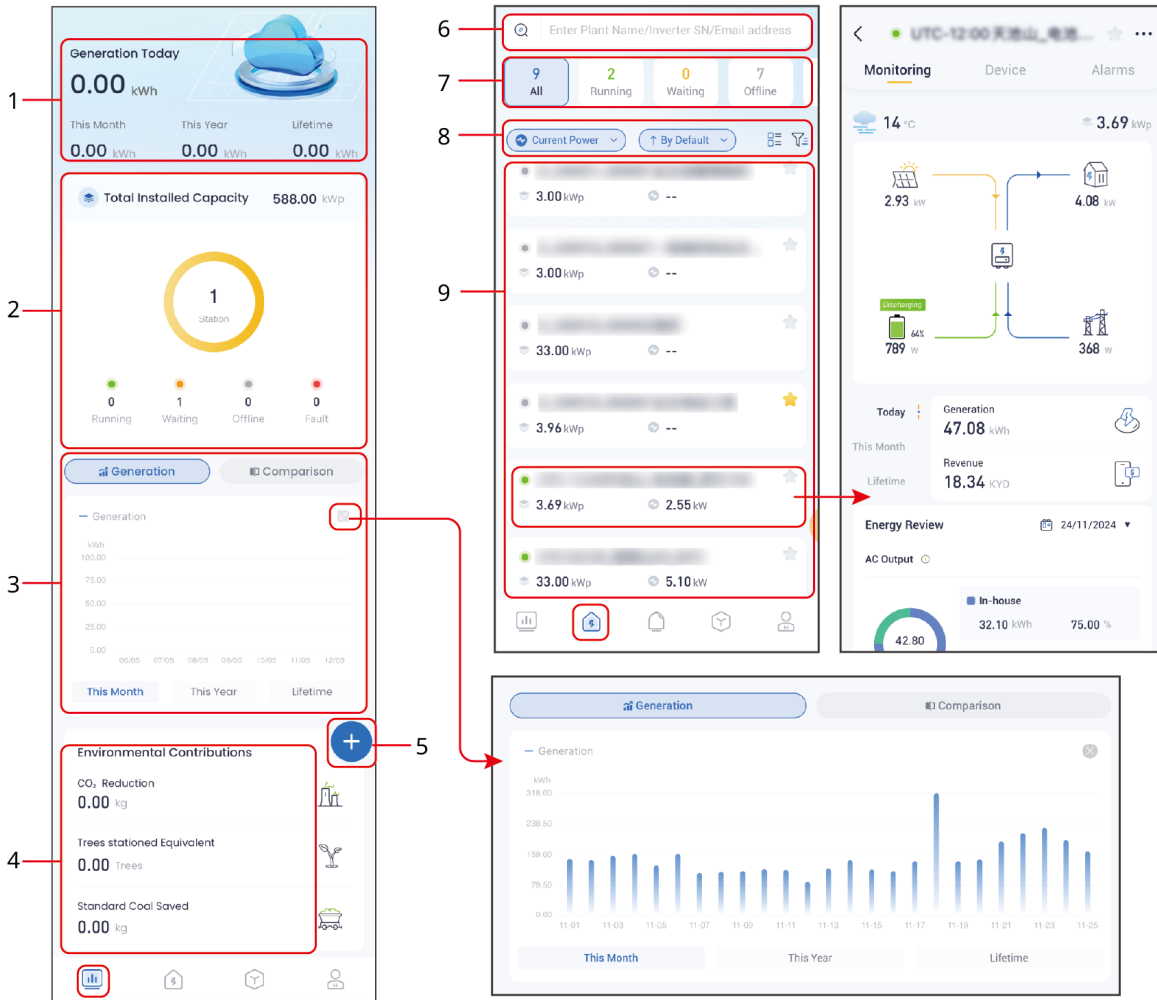

No.	Description
1	Displays the overall generation information of all stations, including: Generation Today, Generation This Month, Generation This Year, and Generation Lifetime. Generation This Year will not be displayed if the station amount exceeds 10.
2	Displays the total installed capacity and the working status of the stations. Working status: Running, Waiting, Offline, and Faulted. The stations status is running only when all the devices of the station are working properly.
3	Displays statistical chart of Generation Today, This Year, and Lifetime.Or displays comparison chart comparing current and past generation. Tap  to expand the chart.
4	Displays environmental contributions like <b>CO<sub>2</sub> Reduction</b> , <b>Trees Stationed Equivalent</b> , and <b>Standard Coal Saved</b> .
5	Creating a New Station

No.	Description
6	Searching Stations Enter the device SN, power station name or email address to quickly search for the corresponding power station.
7	Power station operation status. Display the current operation status of power stations and the number of power stations operating in each status. Tap the operation status to filter power stations in the corresponding operation status.
8	<ul style="list-style-type: none"> <li>• Set KPI indicators displayed in the power station list: Current Power, Rev. Today, Rev. Total, Gen. Today, Gen. Total</li> <li>• Set the sorting method of the power station list: By Default, By Capacity</li> <li>• Set the display mode of the power station list: Station Card, Station List</li> <li>• Set the filtering conditions for the power station list: Scope, Category, Capacity</li> </ul>
9	Power station list. Tap the power station name to view the detailed information of the power station. The displayed content varies depending on the station type. The actual interface takes precedence

### 10.1.3.2 Checking Detailed Information of Single Station

**Step 1:** Enter the device SN, power station name or email address to quickly search for the corresponding power station.

**Step 2:** Tap the power station name to enter the power station details page.

SEMS0052

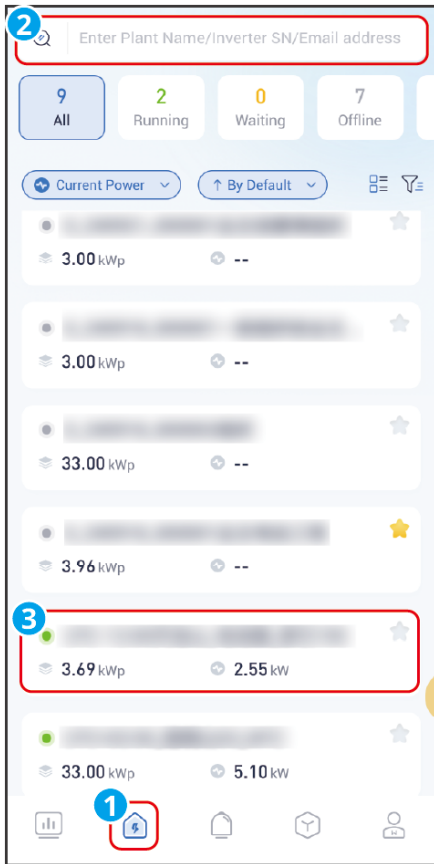

### 10.1.3.2.1 Checking Detailed Information of Power Station (Traditional Mode)

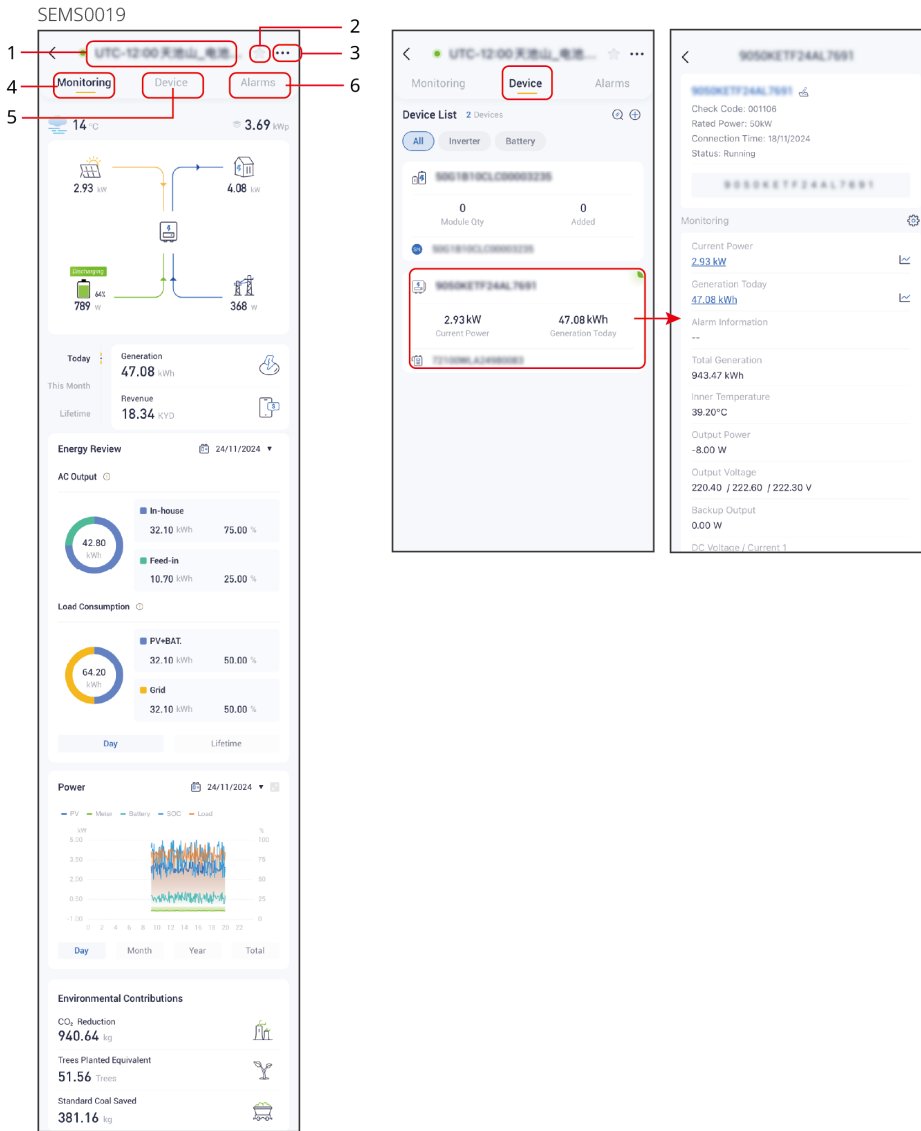

No.	Description
1	The current name of the power station.
2	Favoriting a Station
3	Configuring Station Information. Supported functions: Configure basic information of the power station, modify user information, add power station photos, set PV module layout, etc.
4	Displays current power station operation information in chart form, such as energy flow diagrams, power generation, load power consumption, AC output, and other information.

No.	Description
5	<ul style="list-style-type: none"> <li>• Device List Displays devices in the current power station, such as inverters, batteries, data collectors, charging piles, etc.</li> <li>• Tap the device card to view detailed device information.</li> </ul>
6	Alarm information.

## 10.1.4 Checking Alarm Information

### 10.1.4.1 Checking Alarm Information of All Power Stations

**Step 1** Tap **Alarms** tab to enter the alarm page.

**Step 2** (optional) Use the search bar to locate alarms by station name or device serial number.

**Step 3** Select the alarm to view detailed information.

SEMS0020

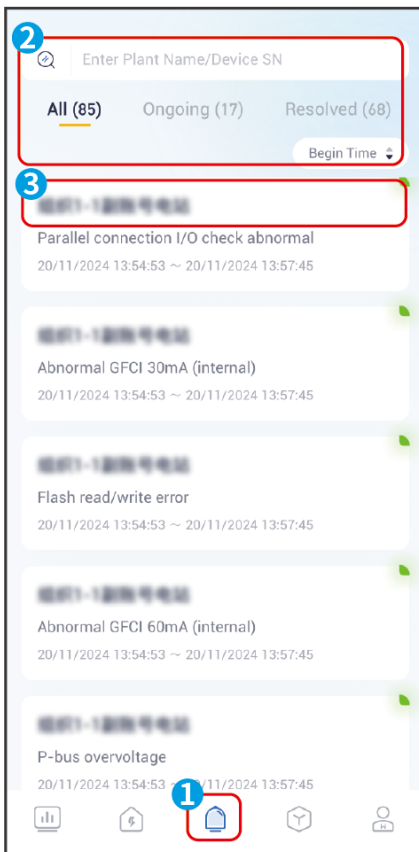

## 10.1.4.2 Checking Alarm Information of Current Stations

### 10.1.4.2.1 Checking Detailed Information of Current Power Station (Traditional Mode)

**Step 1:** If there are multiple power stations, tap the power station name to enter the power station details page.

**Step 2:** Tap **Alarms** to enter the alarm page to view alarm details. Tap  to filter alarm information based on actual needs.

SEMS0021

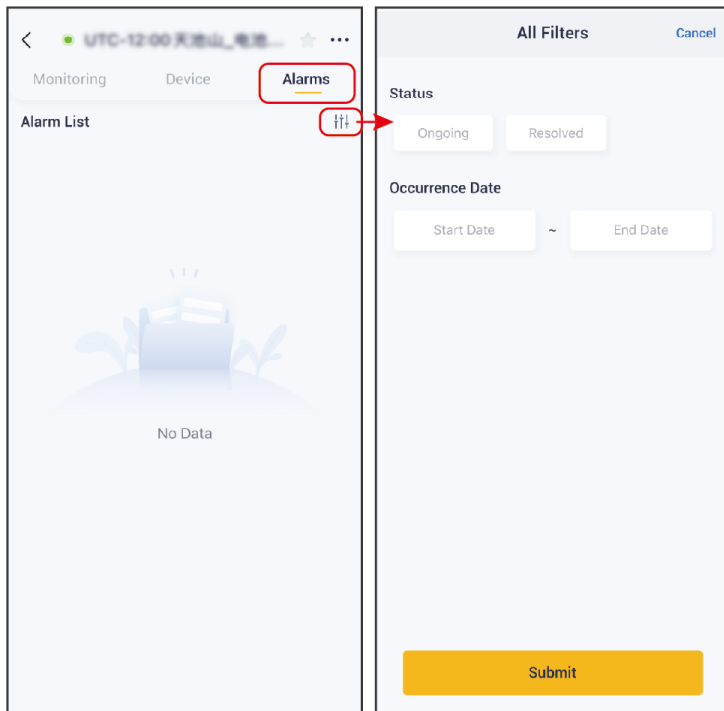

## 10.1.4.3 Checking Alarm Information of Current Devices

**Step 1:** If there are multiple power stations, tap the power station name to enter the power station details page.

**Step 2:** Select a device from the device list and enter the device details page. If there are alarms, the device details page allows direct viewing of the 10 latest ongoing alarms.

SEMS0022

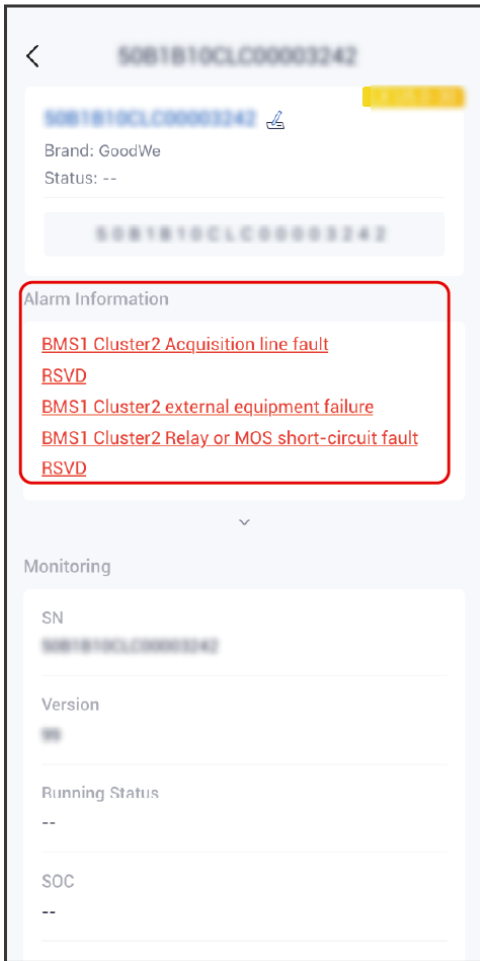

## 10.1.5 Checking Station Reports

### Viewing Reports

**Step 1:** Tap **Service** > **Report Center**.

**Step 2:** Select a time period, search for the desired station, and tap the station name to view the report center. Tap **⋮** > **Export** to download the report if needed.





## Viewing Bills

Step 1: Tap Service > Report Center.

**Step 2:** Search for the desired station. Find the station, swipe left and tap  to view billing details of the month.

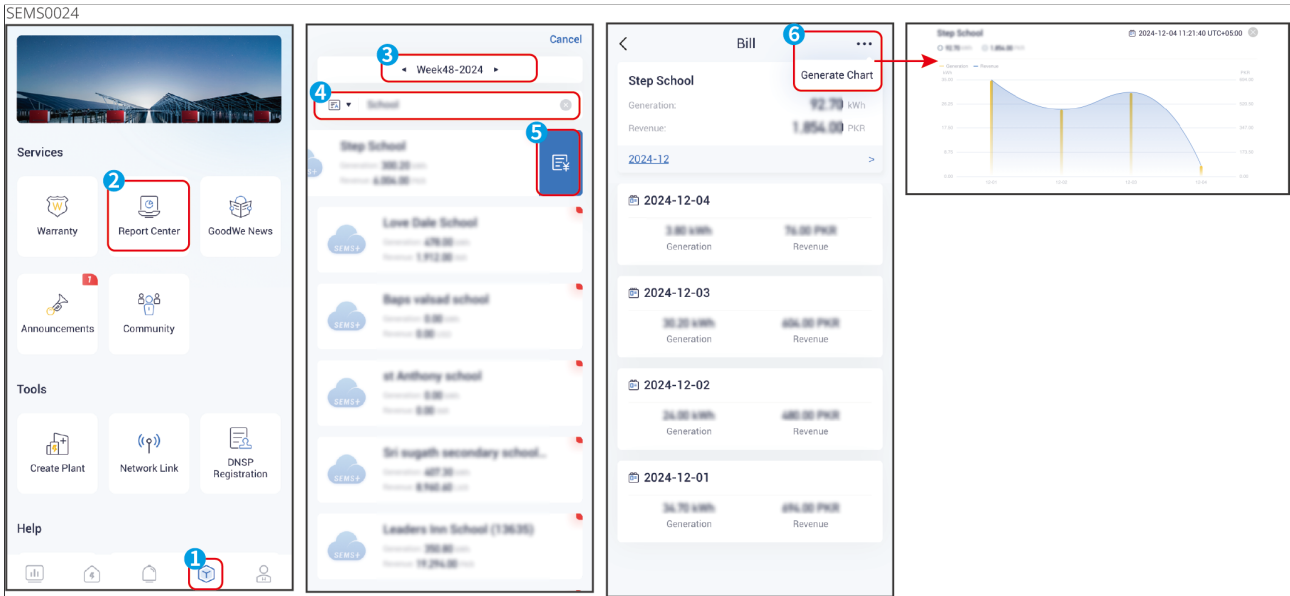

## 10.1.6 Managing Stations

### 10.1.6.1 Creating a Station

**Step 1:** Tap  on overview or station page, or tap **Create Station** on service page.

**Step 2:** Enter station information on the **Creat Station** page.

**Step 3:** Tap **Save&Exit** to complete creating a station, without devices added. Or tap **Save&Continue** to add devices. Support adding multiple devices.

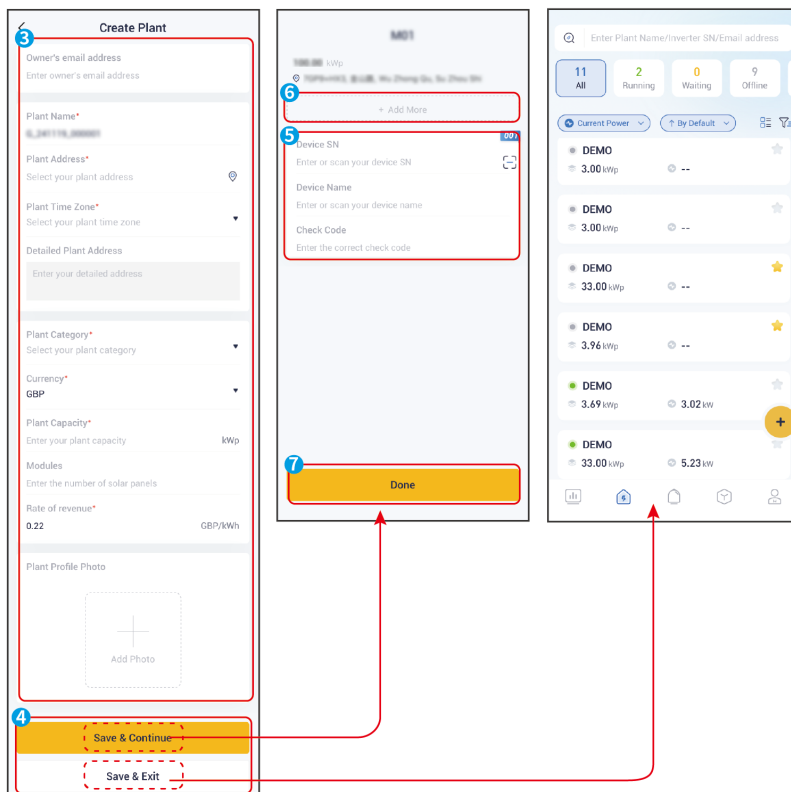
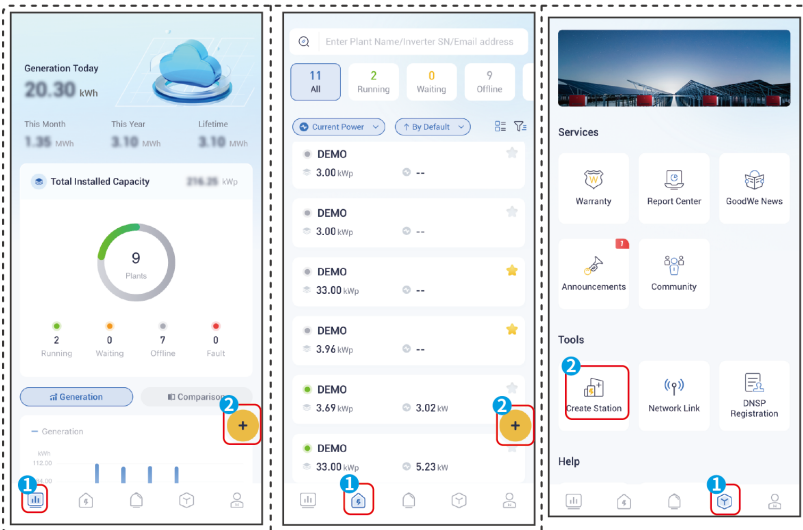

### 10.1.6.2 Configuring Station Information

#### NOTICE

The configuration information of the station can be updated as needed. When the information filled in is inconsistent with the actual situation of the power station, the actual situation of the power station shall prevail.

**Step 1:** (Optional) Select the station to be updated from the station list.

**Step 2:** Tap **⋮** > **Basic Information** to check the basic information.

**Step 3:** Tap **⚙️** to modify the information, and tap **Confirm** to save the changes.

SEMS0012

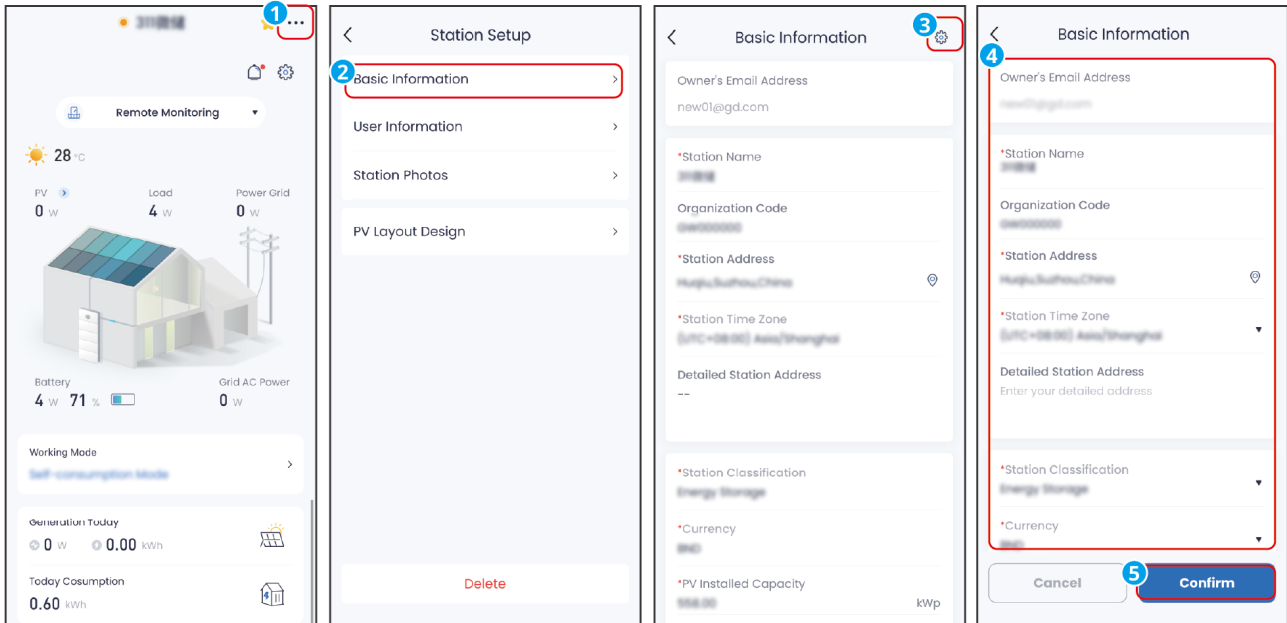

### 10.1.6.3 Managing Station Visitors

SEMS+ App allows users to add visitors to the power station and view basic information. Visitors have limited access and cannot view all information.

**Step 1:** (Optional) Select the station to be updated from the station list.

**Step 2:** Tap **⋮** > **User Information** > **Add**.

**Step 3:** Input the visitor's information and tap **Confirm**.

SEMS0013

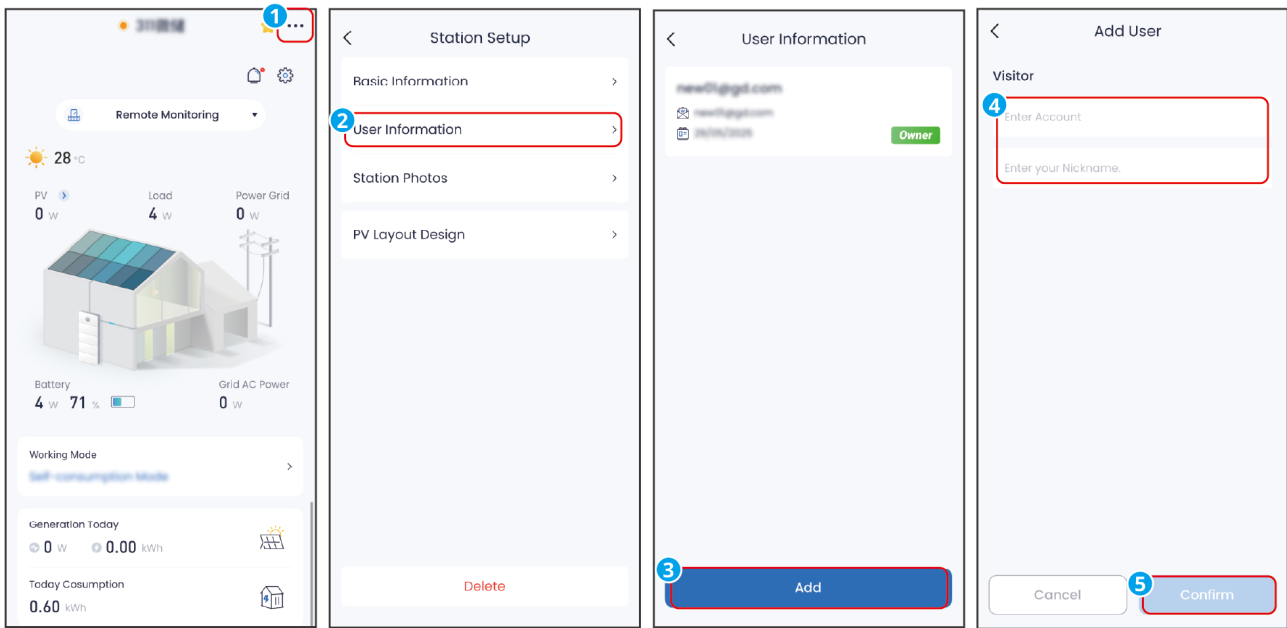

To delete a visitor, go to the User Information page, select the visitor, and tap **Delete**.

SEMS0054

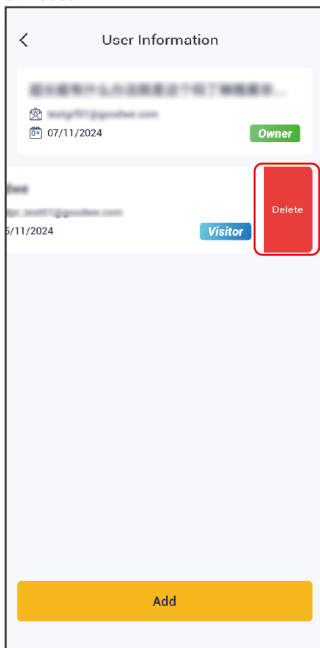

#### 10.1.6.4 Managing Station Photos

Adding photos to a station helps users find what they need faster.

**Step 1:** (Optional) Select the station to be updated from the station list.

**Step 2:** Tap **☰** > **Station Photos** > **Add**.

**Step 3:** Follow the prompts to add photos by **Take a Photo** or **Choose from Album**.

SEMS0014

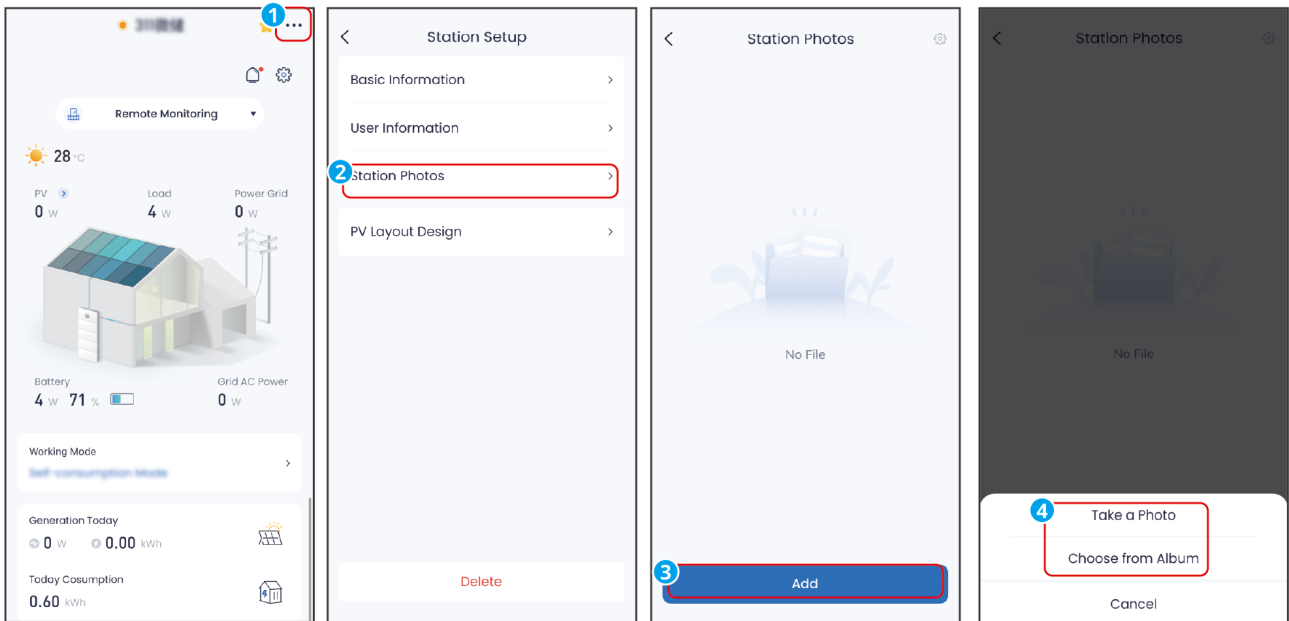

To delete a photo, follow the steps below.

SEMS0055

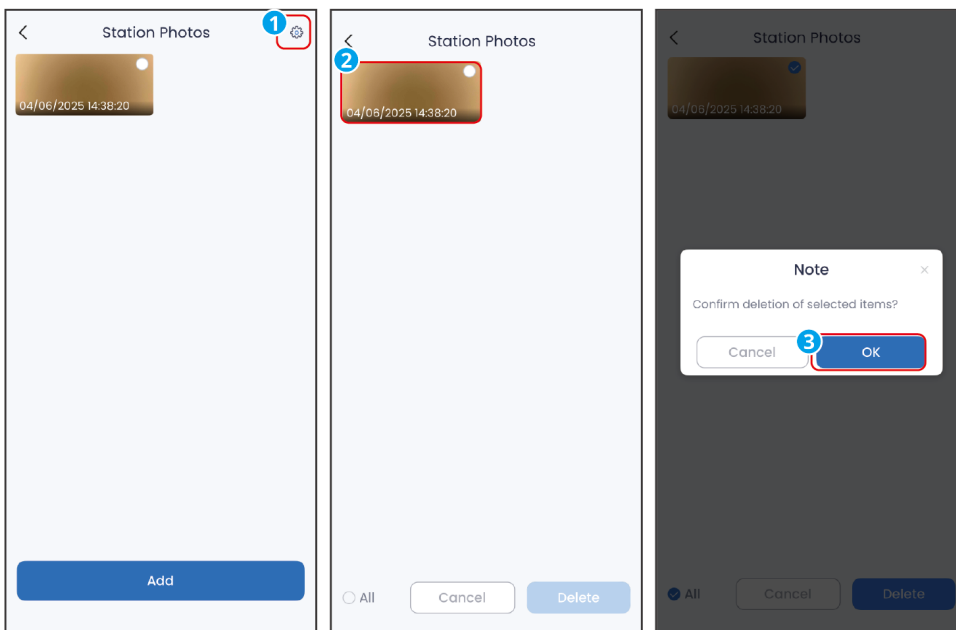

### 10.1.6.5 Set PV Module Layout

Set the PV Layout Design parameters based on the actual conditions of PV modules. The information here is only for recording the PV layout and will not change the actual PV layout.

**Step 1:** (Optional) Select the station to be updated from the station list.

**Step 2:** Tap **•••** > **PV Layout Design** to enter the interface.

**Step 3:** Tap **Row/Column**, and set the arrangement of modules in each row and each

column based on the actual installation of PV modules.

**Step 4: Tap Array Name** to enter the **Array Settings** interface, and set the name, angle, and orientation information of the PV array based on the actual situation.

SEMS0056

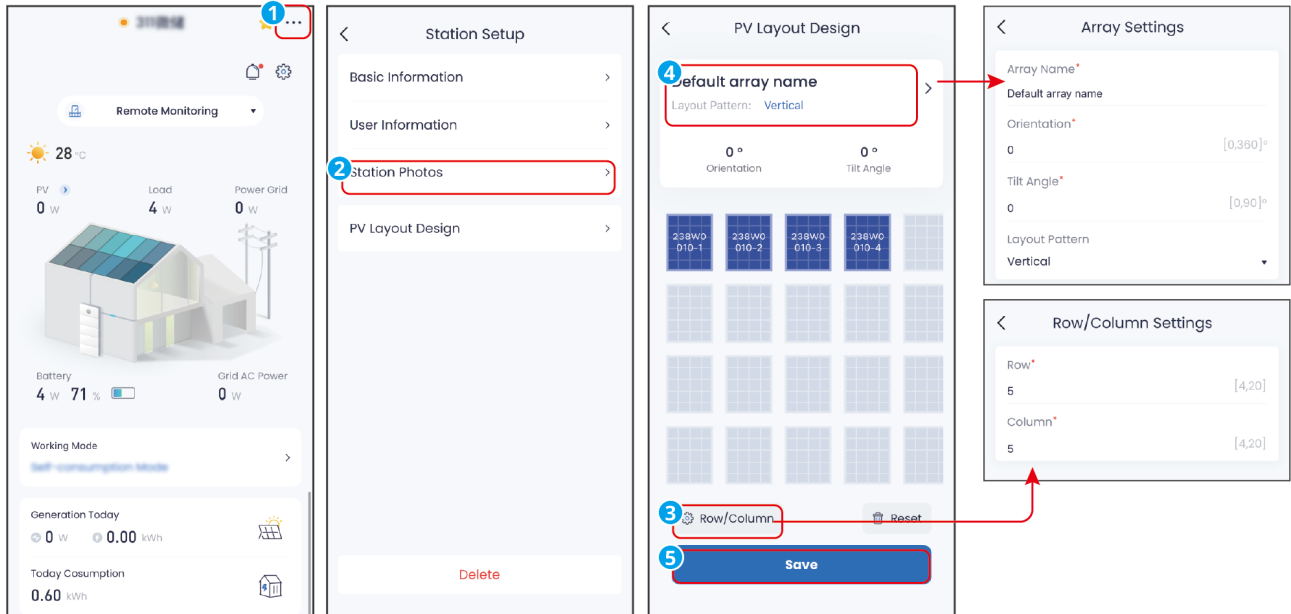

### 10.1.6.6 Configuring the Page Information

Change what's shown on the station details page, such as showing, hiding, or repositioning the Energy Flow Chart.

**Step 1:** (Optional) Select the station to be updated from the station list.

**Step 2:** Tap **•••** > **Home Configuration** on the station page.

**Step 3:** Refer to the on-screen prompts to select the information content to be displayed, or adjust the display order of various information based on actual needs.

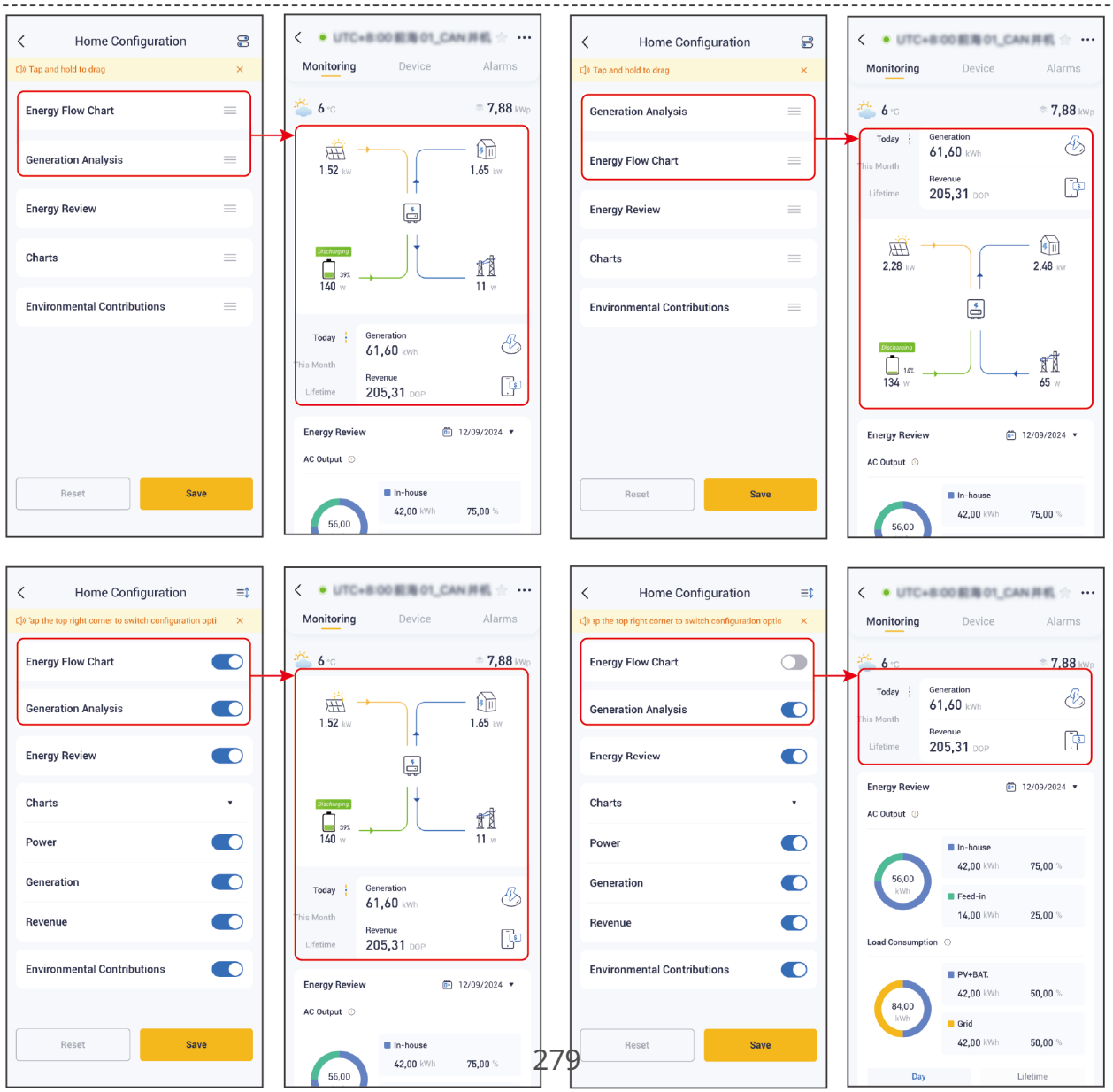
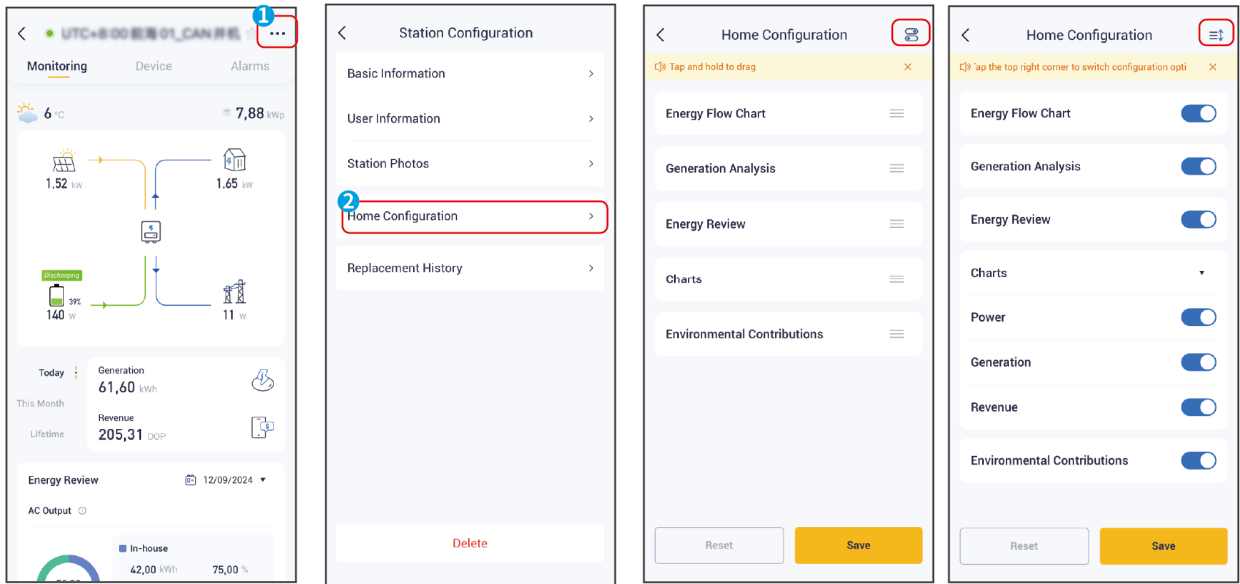

### 10.1.6.7 Deleting a Station



(Optional) If there are multiple power stations, tap the power station name to enter the power station details page.

**Step 2:** Tap  on the station page.

**Step 3:** Tap **Delete** and **Confirm** to delete the station.

SEMS0016

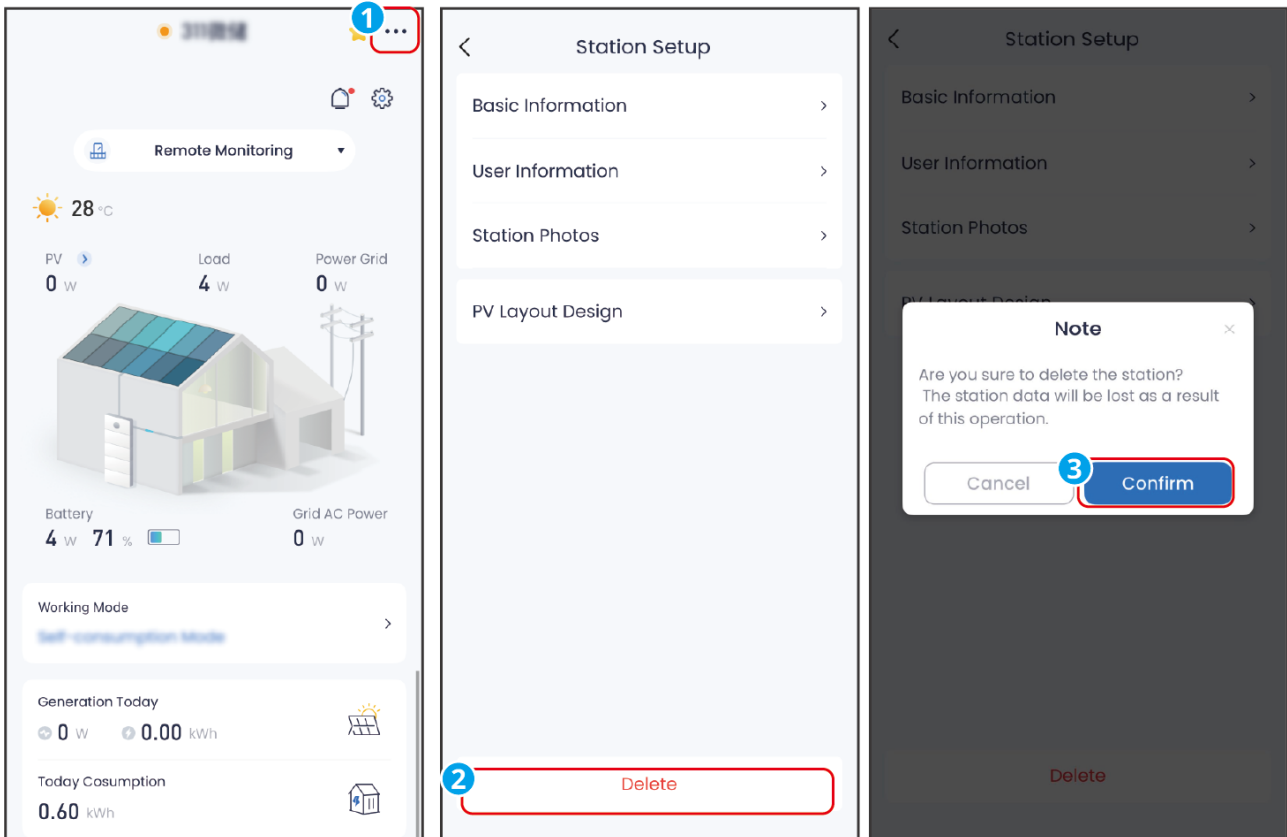

### 10.1.6.8 Favoriting a Station

To favorite a station, tap the star icon  next to the station name. Tap the icon again to unfavorite it.

Tap  and Select Favorited in the filtering Scope to display all the favorited power stations.

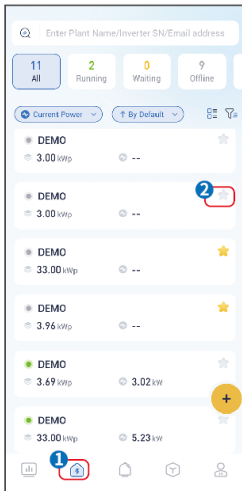

## 10.1.7 Managing Devices

### 10.1.7.1 Adding a Device

#### NOTICE

- Supported device types may vary based on the station type.
- If the environmental monitor is connected to a smart logger, add the environmental monitor to the station and view the its data.

**Step 1:** Select a station from the station list.

**Step 2:** Tap **Device** >  $\oplus$  to enter the device addition interface.

**Step 3:** Select the type of device to add.

**Step 4:** Follow the instructions to scan or manually input device information. To add the scanned devices, choose devices from the scanned device list. To manually add a device, scan the device SN code or input required device information. To add multiple devices, repeat the steps as needed.

**Step 5:** When manually adding devices, if you need to add multiple devices, return to the power station details page and repeat steps 3 and 4.

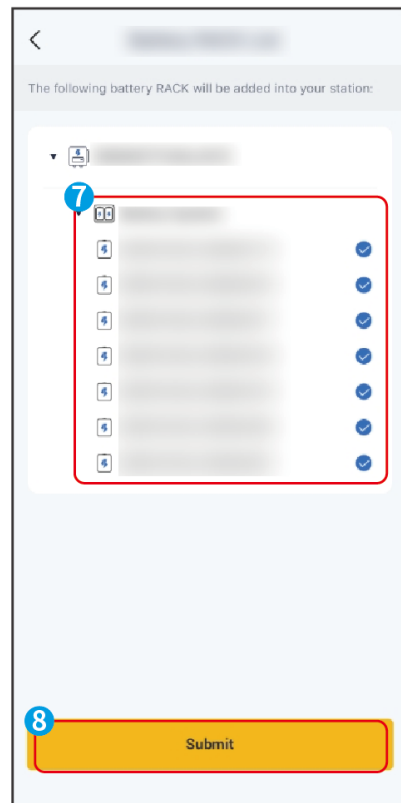
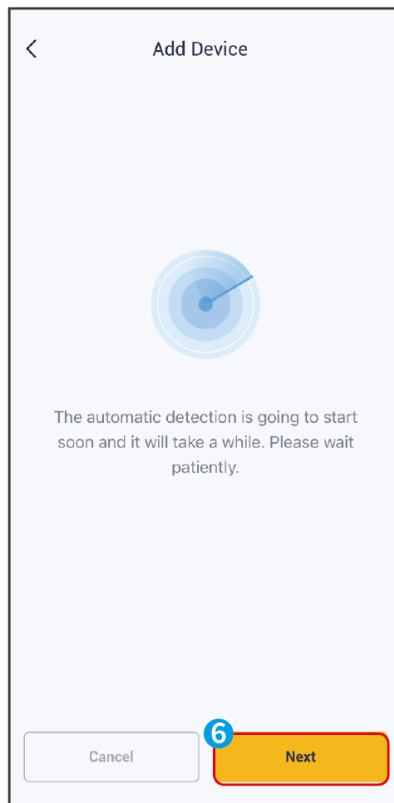
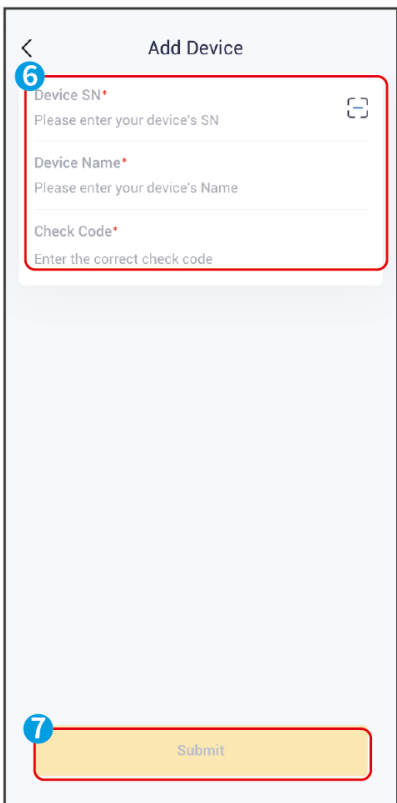
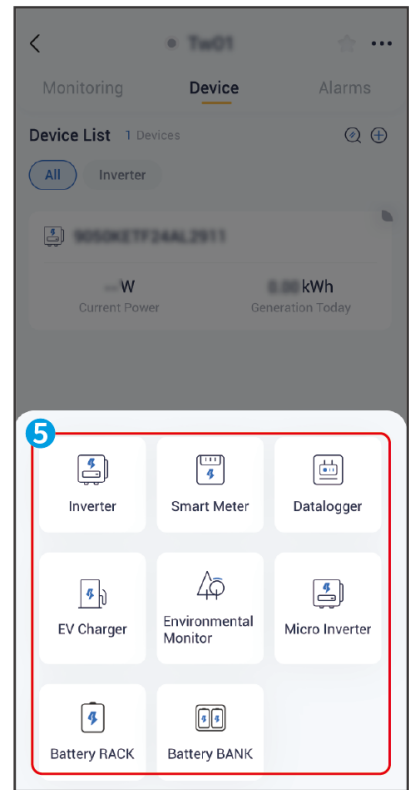
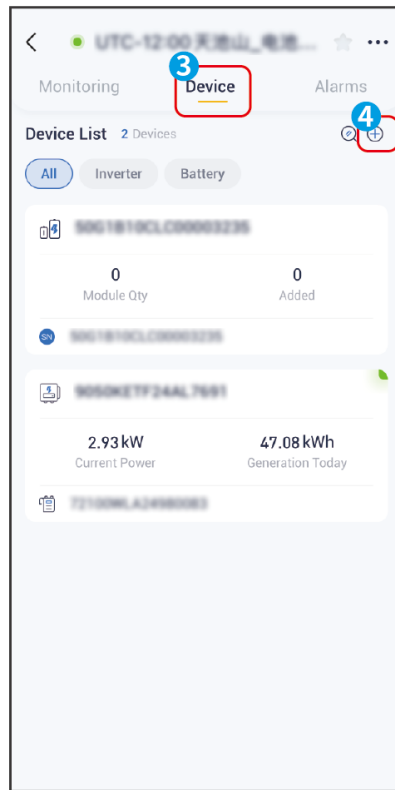
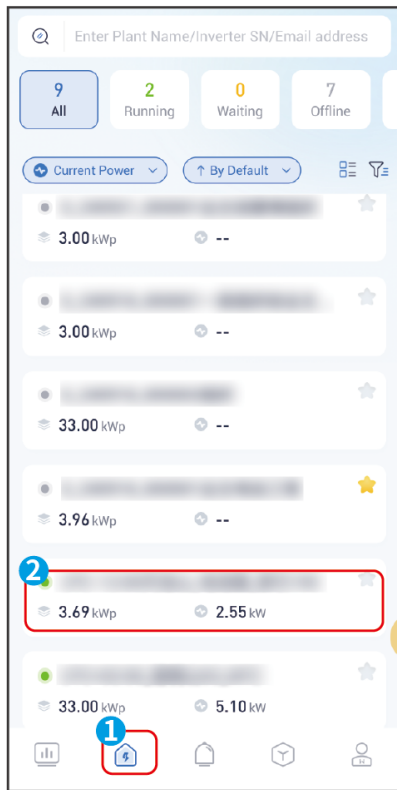

### 10.1.7.2 Editing Device Information

The device name can be modified.

**Step 1:**(Optional) If there are multiple power stations, tap the power station name to enter the power station details page.

**Step 2:**Tap **Device** to enter the device page. Select the device and swipe left, tap .

**Step 3:** Input new device name and tap **Submit**.

SEMS0027

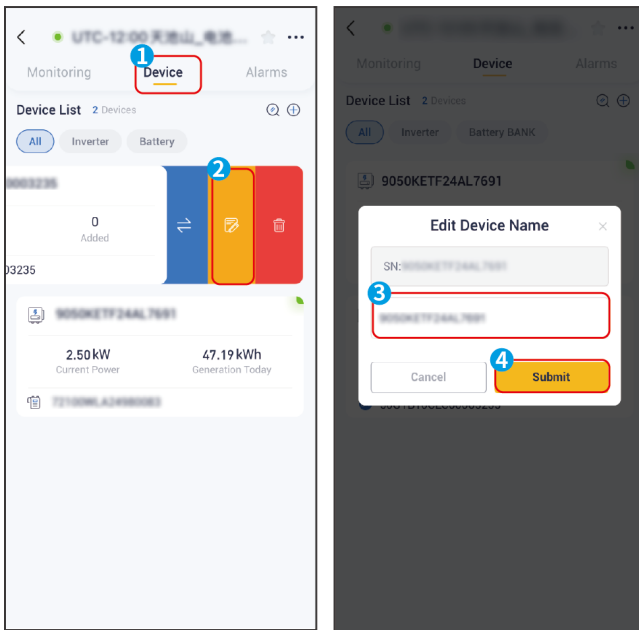

### 10.1.7.3 Deleting a Device

**Step 1:**(Optional) If there are multiple power stations, tap the power station name to enter the power station details page.

**Step 2:**Tap **Device** to enter the device page. Select the device and swipe left, tap .

**Step 3:** Read the prompt and tap **OK** to delete the device.

SEMS0028

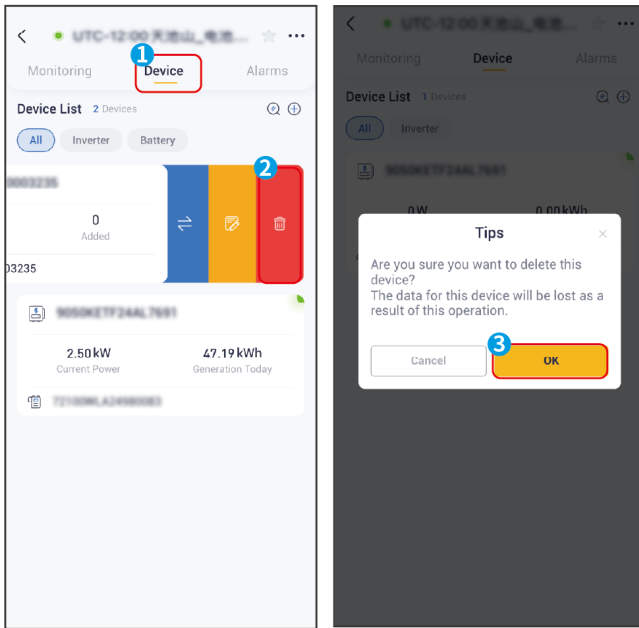

#### 10.1.7.4 Upgrade the Firmware

**Step 1:** (Optional) Select the station to be updated from the station list.

**Step 2:** Tap **Device** to open the device details page and select the device to be upgraded.

**Step 3:** Tap the device serial number to enter the **Firmware Version** page. If the upgrade is available, tap **Upgrade** and follow the instructions. Tap ⌚ to find the upgrade history.

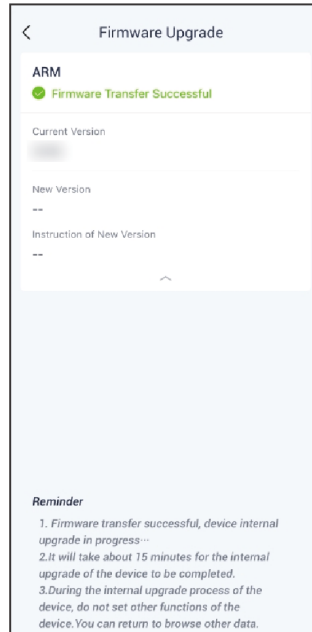
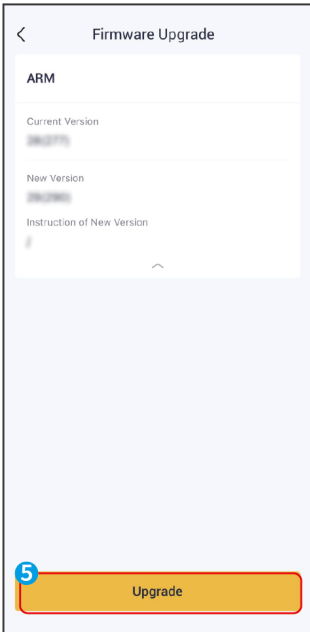
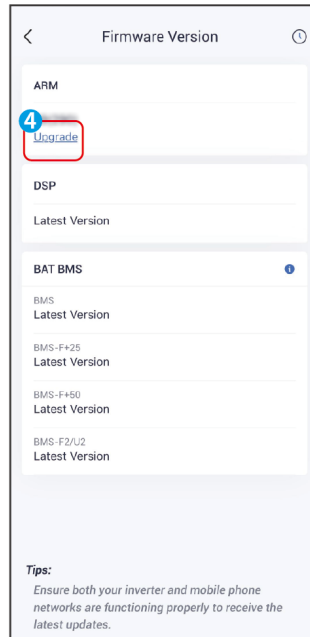
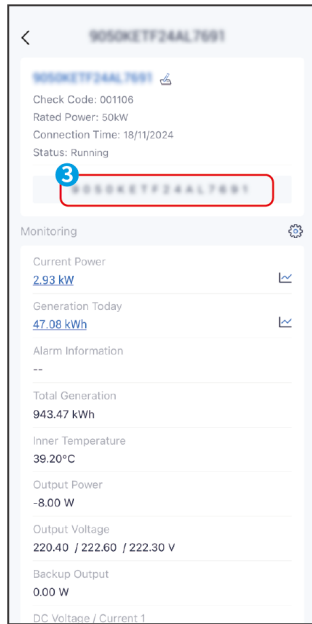
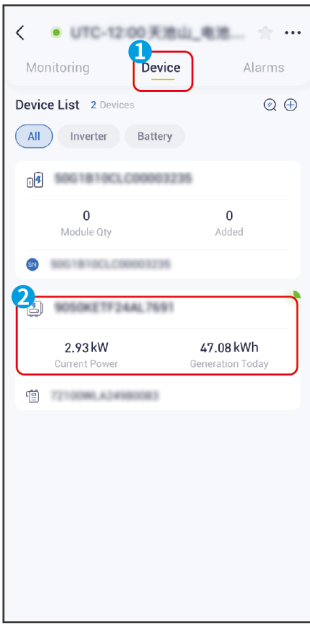

## 10.1.8 Managing Device Remotely

## NOTICE

- Set the device parameters via SEMS+ App after creating a plant and adding devices to it.
- Before setting any parameters, read through user manual of the App and the inverter or charger to learn the product functions and features. Incorrectly configured parameters, such as grid settings or start/stop commands, may result in devices failing to connect to the grid, potentially affecting power generation.
- λ Only trained professionals familiar with local regulations and electrical systems should perform parameter settings.
- Different account permissions allow for remote setting of different parameters. The interface will be displayed based on the actual account in use, and please refer to the actual interface.
- The setting page varies depending on accounts type and device model.

### 10.1.8.1 Configuring Hybrid Inverter Parameters

**Step 1:** (Optional) Select the station to be updated from the station list.

**Step 2:** Tap **Device** to enter the device page and choose the device to be configured.

**Step 3:** Tap , read the prompts and set parameters as needed.

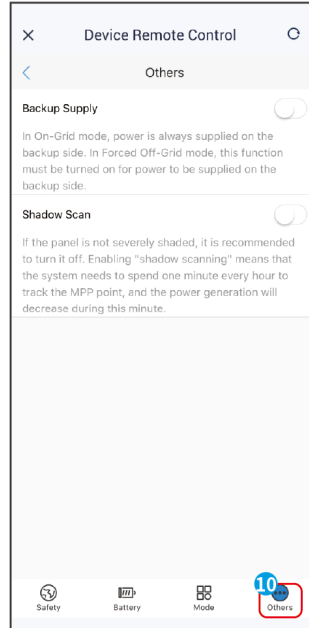
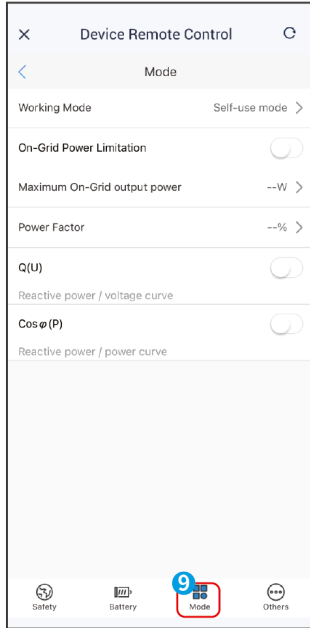
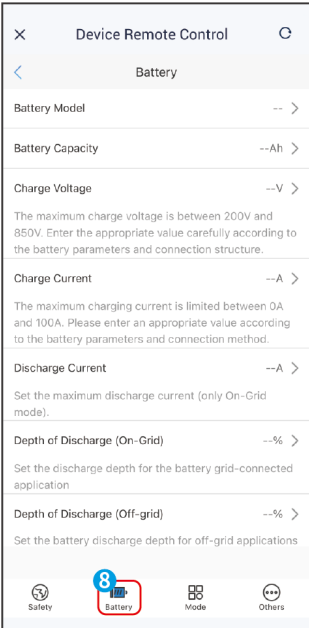
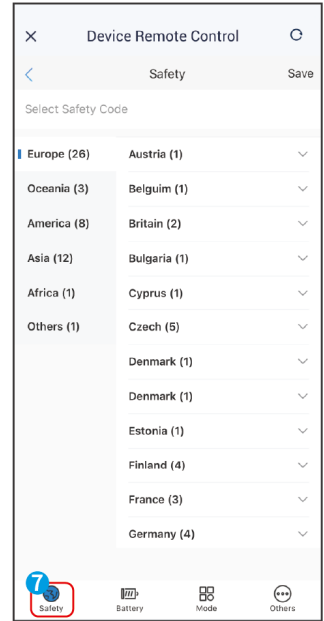
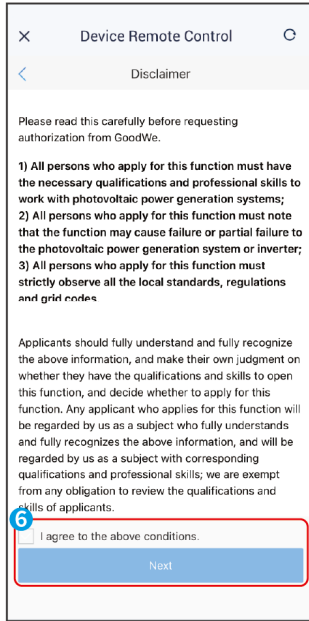
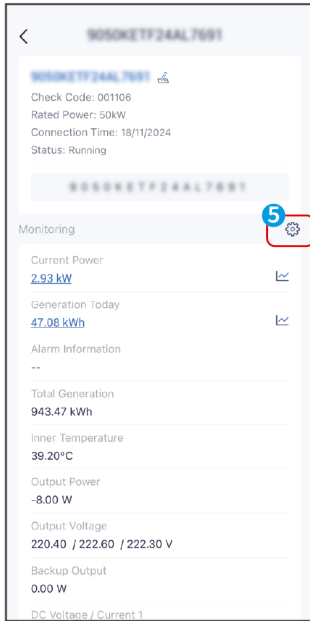
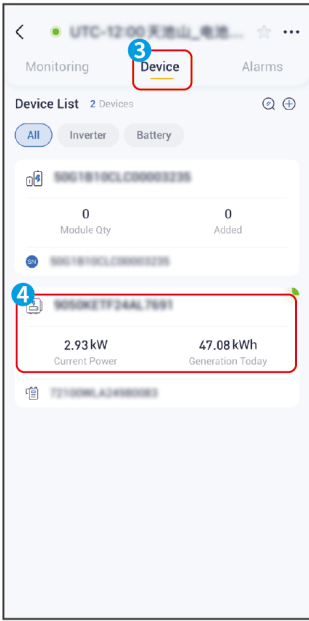

No.	Parameters	Description
1	Safety	Set the safety country in compliance with local grid standards and application scenario of the inverter.
Battery		
2	Battery Model	Set the model of the connected battery.
3	Depth of Discharge (On-Grid)	The maximum depth of discharge of the battery when the system is working on-grid.



<b>No.</b>	<b>Parameters</b>	<b>Description</b>
4	Depth of Discharge (Off-Grid)	The maximum depth of discharge of the battery when the system is working off-grid.
5	Backup SOC Holding	The battery will be charged to preset SOC protection value by utility grid or PV when the system is running on-grid. So that the battery SOC is sufficient to maintain normal working when the system is off-grid.
6	SOC Protection	Start battery protection when the battery capacity is lower than the Depth of Discharge.

No.	Parameters	Description
7	Battery Heating	<p>When a battery with heating function is connected, this option will be displayed on the interface. After enabling the battery heating function, when the battery temperature does not support battery startup, PV power generation or purchased electricity will be used to heat the battery.</p> <p>Heating modes:</p> <ul style="list-style-type: none"> <li>• GW5.1-BAT-D-G20/GW8.3-BAT-D-G20 <ul style="list-style-type: none"> <li>◦ Low-power mode: Maintain the minimum power input capability of the battery. It turns on when the temperature is below -9°C and turns off when the temperature is -7°C or higher.</li> <li>◦ Medium-power mode: Maintain moderate power input capability of the battery. It turns on when the temperature is below 6°C and turns off when the temperature is 8°C or higher.</li> <li>◦ High-power mode: Maintain high power input capability of the battery. It turns on when the temperature is below 11°C and turns off when the temperature is 13°C or higher.</li> </ul> </li> <li>• GW14.3-BAT-LV-G10 <ul style="list-style-type: none"> <li>◦ Low-power mode: Maintain the minimum power input capability of the battery. It turns on when the temperature is below 5°C and turns off when the temperature is 7°C or higher.</li> <li>◦ Medium-power mode: Maintain moderate power input capability of the battery. It turns on when the temperature is below 10°C and turns off when the temperature is 12°C or higher.</li> <li>◦ High-power mode: Maintain high power input capability of the battery. It turns on when the temperature is below 20°C and turns off when the temperature is 22°C or higher.</li> </ul> </li> </ul>
8	Daily Heating Period	Set the battery heating time period based on actual needs.

No.	Parameters	Description
9	Battery Wake-up	After being enabled, the battery can be woken up when it shuts down due to undervoltage protection.
10	Battery Breathing Light	<ul style="list-style-type: none"> <li>• Only applicable to the ESA 3-10kW inverter series. Set the blinking duration of the device's breathing light. Options available: Always on, Always off, 3min.</li> <li>• The default mode is to stay on for three minutes after power-on and then turn off automatically.</li> </ul>
Mode		
11	Working Mode	<p>Set the working mode based on actual needs.</p> <ul style="list-style-type: none"> <li>• Self-use mode: <ul style="list-style-type: none"> <li>◦ Back-up mode: The back-up mode is mainly applied to the scenario where the grid is unstable ;When the grid is disconnected, the inverter turns to off-grid mode and the battery will supply power to the load; when the grid is restored, the inverter switches to on-grid mode.</li> <li>◦ Eco mode: It is recommended to use economic mode in scenarios when the peak-valley electricity price varies a lot. Select Economic mode only when it meets the local laws and regulations. Set the battery to charge mode during Vally period to charge battery with grid power. And set the battery to discharge mode during Peak period to power the load with the battery.</li> </ul> </li> <li>• Smart charging: In some countries/regions, the PV power feed into the utility grid is limited. Select Smart Charging to charge the battery using the surplus power to minimize PV power waste.</li> <li>• Peak shaving mode:Peak shaving mode is mainly applicable to peak power limited scenarios. When the total power consumption of the load exceeds the power consumption quota in a short period of time, battery discharge can be used to reduce the power exceeding the quota.</li> </ul>

No.	Parameters	Description
12	On-Grid Power Limitation	Enable On-Grid Power Limitation when power limiting is required by local grid standards and requirements.
13	Maximum On-Grid Output Power	Set the value based on the actual maximum power feed into the utility grid.
14	Power Factor	Set the power factor based on actual needs.
15	Q(U)	Enable Q(U) Curve when it is required by local grid standards and requirements.
16	COS( $\varphi$ )	Enable Cos $\varphi$ Curve when it is required by local grid standards and requirements.
17	P(F)	Enable P(F) Curve when it is required by local grid standards and requirements.
Others		
18	Backup Supply	After enabling Backup Supply, the battery will power the load connected to the BACK-UP port of the inverter to ensure Uninterrupted Power Supply when the power grid fails.
19	Shadow Scan	Enable Shadow Scan when the PV panels are severely shadowed to optimize the power generation efficiency.

# 11 Maintenance

## 11.1 Power Off the System

### DANGER

- Power off the equipment before operations and maintenance. Otherwise, the equipment may be damaged or electric shocks may occur.
- Delayed discharge. Wait until the components are discharged after power off.
- Push the air switch to restart the battery.
- Strictly follow the power off requirements to avoid damaging the system.
- When there are multiple batteries in the system, powering off any one of the batteries can power off all the batteries.

### NOTICE

- Install the circuit breaker between the inverter and the battery or between the two batteries in compliance with local laws and regulations.
- To ensure effective protection, the cover of the battery system switch should remain closed. The cover can be closed automatically after being opened. Fasten the cover with screws if the switch is not to be used for a long-term period.

### Power down process

1. Turn off the BACK-UP circuit breaker.
2. Turn off the ON-GRID circuit breaker.
3. (Optional) Turn off the GEN circuit breaker.
4. (Selected in accordance with local laws and regulations) Turn off the circuit breaker between the PV module and the inverter.
5. Turn off the DC switch of the inverter.
6. (Selected in accordance with local laws and regulations) Turn off the switch between the inverter and the battery.
7. Turn off the battery system switch.
8. Turn off the battery system switch (LX A5.0-10, LX A5.0-30). Turn off the battery

system integrated circuit breaker or press and hold the battery system button for  $\geq 5$  seconds, and the battery system integrated circuit breaker will automatically turn off (only applicable to LX U5.0-30 and GW14.3-BAT-LV-G10).

## 11.2 Removing the Equipment



- Make sure that the equipment is powered off.
- Wear proper PPE during operations.
- Please use standard disassembly tools when removing wiring terminals to avoid damaging the terminals or equipment.
- Unless otherwise specified, the dismantling process of the equipment is in reverse order to the installation process, and it will not be further elaborated in this document.

1. Power off the System.
2. Label the cables connected in the system with tags indicating the cable type.
3. Disconnect the connecting cables of the inverter, battery, and smart meter in the system, such as DC cables, AC cables, communication cables, and PE cables.
4. Remove equipment such as the smart dongle, inverter, battery, and smart meter.
5. Properly store the equipment and ensure that the storage conditions meet the requirements if it needs to be put into use later.

## 11.3 Disposing of the Equipment

If the equipment cannot work anymore, dispose of it according to the local disposal requirements for electrical equipment waste. The equipment cannot be disposed of together with household waste.

## 11.4 Routine Maintenance



- Contact after-sales service for help if you find any problems that may influence the battery or the hybrid inverter. Disassemble without permission is strictly forbidden.
- Contact after-sales service for help if the copper conductor is exposed. Do not touch or disassemble privately because high voltage danger exists.
- In case of other emergencies, contact the after-sales service as soon as possible. Operate following the instructions or wait for the after-sales service personnel.

Maintaining Item	Maintaining Method	Maintaining Period	Maintaining Purpose
System clean	Check the heat sink, air intake, and air outlet for foreign matter or dust. Check whether the installation space meets requirements and whether there is any debris around the device.	Once half a year	Prevent heat dissipation failures.
System installation	Check whether the equipment are installed securely and whether the screws are installed tightly. Check whether the equipment is damaged or deformed.	Once 6-12 months	Ensure that the equipment is installed securely.
Electrical connection	Check whether the cables are securely connected. Check whether the cables are broken or whether there is any exposed copper core.	Once 6-12 months	Confirm the reliability of electrical connections.
Sealing	Check whether all the terminals and ports are properly sealed. Reseal the cable hole if it is not sealed or too big.	Once a year	Confirm that the machine seal and waterproof performance are intact.

Maintaining Item	Maintaining Method	Maintaining Period	Maintaining Purpose
Battery maintenance	If the battery is not used for a long time or is not fully charged, it is recommended to charge the battery regularly.	Once/15 days	Protect the battery's lifespan.

## 11.5 Fault

### 11.5.1 Viewing Fault/Alarms Information

All detailed information about faults/alarms in the energy storage system is displayed on the **SolarGo App**, **SEMS Portal App**, and LCD display screen. If your product has any abnormalities and no relevant fault information is seen on the **SolarGo App**, **SEMS Portal App**, or LCD display screen, please contact the after-sales service center.

- **Viewing method one: LCD screen**

Click or select the fault information icon  on the screen to view energy storage system alarms or fault information.

- **Viewing Method 2: SolarGo App**

View energy storage system alarm information through **Home>Parameters>Alarms**.

- **Viewing Method 3: SEMS Portal App**

1. Open the SEMS Portal App and log in with any account.
2. All power station fault information can be viewed through the **Power Plant >Alarm**.
3. Click on the specific fault name to view detailed information about the fault: [time of occurrence], [possible cause], and [solution].

### 11.5.2 Fault Information and Troubleshooting

Perform troubleshooting according to the following methods. Contact the after-sales service if these methods do not work.

Collect the information below before contacting the after-sales service, so that the







problems can be solved quickly.

1. Product information like serial number, software version, installation date, fault time, fault frequency, etc.
2. Installation environment, including weather conditions, whether the PV modules are sheltered or shadowed, etc. It is recommended to provide some photos and videos to assist in analyzing the problem.
3. Utility grid situation.

### 11.5.2.1 System failure.

If unlisted problems occur in the system, or if following the instructions does not stop the problem or abnormality, stop operating the system immediately and contact your dealer immediately.

No.	Fault	Solutions/measures to address the issue
1	Unable to search for the wireless signal of the smart dongle.	<ol style="list-style-type: none"> <li>1. Please ensure that no other devices are connected to the smart dongle's wireless signal.</li> <li>2. Please ensure that the SolarGo app has been updated to the latest version.</li> <li>3. Please ensure that the smart dongle is powered on properly, and the blue indicator light is blinking or steady on.</li> <li>4. Ensure that the smart device is within the communication range of the smart dongle.</li> <li>5. Refresh the device list in the app.</li> <li>6. Restart the inverter.</li> </ol>
2	Unable to connect to the wireless signal of the smart dongle.	<ol style="list-style-type: none"> <li>1. Please ensure that no other devices are connected to the smart dongle's wireless signal.</li> <li>2. Restart the inverter or smart dongle, and try to reconnect to the wireless signal of the smart dongle again.</li> <li>3. Ensure successful pairing of Bluetooth.</li> </ol>

No.	Fault	Solutions/measures to address the issue
3	 The Ezlink indicator flashes twice.	<ol style="list-style-type: none"> <li>1. Make sure that the router is powered on.</li> <li>2. When communicating via LAN, make sure that both LAN cable connection and LAN configuration are proper. Enable or disable DHCP based on actual needs.</li> <li>3. When communicating via WiFi, make sure that the wireless network connection is OK and the wireless signal strength meets the requirements. Enable or disable DHCP based on actual needs.</li> </ol>
4	 The Ezlink indicator flashes four times.	<ol style="list-style-type: none"> <li>1. Make sure that the smart dongle is connected to the router via WiFi or LAN properly, and the router can access the Internet.</li> <li>2. If the problem persists, contact the after sales service.</li> </ol>
5	 The Ezlink indicator is off.	<p>Make sure that the inverter is powered on. If the problem persists, contact the after sales service. If the problem persists, contact the after sales service.</p>
6	 The Ezlink indicator is off.	<p>Make sure that the inverter is powered on. If the problem persists, contact the after sales service.</p>
7	Cannot find router SSID.	<ol style="list-style-type: none"> <li>1. Put the router nearer to the Smart Dongle. Or add a WiFi relay device to enhance the WiFi signal.</li> <li>2. Reduce the number of devices connected to router.</li> </ol>
8	After completing all configurations, the Smart Dongle fails connecting to the router.	<ol style="list-style-type: none"> <li>1. Restart the inverter.</li> <li>2. Check if the SSID, encryption method and password on WiFi configuration page are the same with that of Router.</li> <li>3. Restart the router.</li> <li>4. Put the router nearer to the Smart Dongle. Or add a WiFi relay device to enhance the WiFi signal.</li> </ol>

No.	Fault	Solutions/measures to address the issue
9	After completing all configurations, the Smart Dongle fails connecting to the router.	Restart the router and the inverter.

### 11.5.2.2 Inverter Troubleshooting

No.	Fault	Cause	Troubleshooting Suggestions
1	Grid Power Outage	<ul style="list-style-type: none"> <li>1. Utility grid power fails.</li> <li>2. The AC circuit or the AC breaker is disconnected.</li> </ul>	<ul style="list-style-type: none"> <li>1. The alarm is automatically cleared after the grid power supply is restored.</li> <li>2. Check whether the AC cable is connected and the AC breaker is on.</li> </ul>

No.	Fault	Cause	Troubleshooting Suggestions
2	Grid Overvoltage	The grid voltage is higher than the permissible range or the high voltage duration exceeds the high voltage ride-through setting.	<p>1. If the problem occurs occasionally, the utility grid may be abnormal temporarily. The inverter will recover automatically after detecting that the utility grid is normal.</p> <p>2. If it occurs frequently, please check if the grid voltage is within the allowable range.</p> <ul style="list-style-type: none"> <li>• Contact the local power company if the grid voltage exceeds the permissible range.</li> <li>• Modify the overvoltage protection threshold, HVRT or disable the overvoltage protection function after obtaining the consent of the local power company if the grid frequency is within the permissible range.</li> </ul> <p>3. Check whether the AC breaker and the output cables are connected securely and correctly if the problem persists.</p>

No.	Fault	Cause	Troubleshooting Suggestions
3	Grid Undervoltage	The grid voltage is lower than the permissible range, or the duration of low voltage exceeds the requirement of LVRT.	<p>1. If the problem occurs occasionally, the utility grid may be abnormal temporarily. The inverter will recover automatically after detecting that the utility grid is normal.</p> <p>2. If it occurs frequently, please check if the grid voltage is within the allowable range.</p> <ul style="list-style-type: none"> <li>• Contact the local power company if the grid voltage exceeds the permissible range.</li> <li>• Modify the undervoltage protection threshold, LVRT or disable the undervoltage protection function after obtaining the consent of the local power company if the grid frequency is within the permissible range.</li> </ul> <p>3. Check whether the AC breaker and the output cables are connected securely and correctly if the problem persists.</p>

No.	Fault	Cause	Troubleshooting Suggestions
4	Grid Rapid Overvoltage	The grid voltage is detected to be abnormal or ultrahigh.	<p>1. If the problem occurs occasionally, the utility grid may be abnormal temporarily. The inverter will recover automatically after detecting that the utility grid is normal.</p> <p>2. If it occurs frequently, please check if the grid voltage is within the allowable range.</p> <ul style="list-style-type: none"> <li>• Contact the local power company if the grid voltage exceeds the permissible range.</li> <li>• Modify the undervoltage protection threshold, LVRT or disable the undervoltage protection function after obtaining the consent of the local power company if the grid frequency is within the permissible range.</li> </ul> <p>3. Check whether the AC breaker and the output cables are connected securely and correctly if the problem persists.</p>

No.	Fault	Cause	Troubleshooting Suggestions
5	Grid 10min Overvoltage	The moving average of grid voltage in 10min exceeds the range of safety requirements.	<ol style="list-style-type: none"> <li>1. If the problem occurs occasionally, the utility grid may be abnormal temporarily. The inverter will recover automatically after detecting that the utility grid is normal.</li> <li>2. Check if the grid voltage is running at a high voltage for a long time. If it occurs frequently, please check if the grid voltage is within the allowable range.</li> </ol> <ul style="list-style-type: none"> <li>• Contact the local power company if the grid voltage exceeds the permissible range.</li> <li>• If the grid voltage is within the allowable range, please modify the Grid 10min Overvoltage protection value with the consent of the local power operator.</li> </ul>

No.	Fault	Cause	Troubleshooting Suggestions
6	Grid Overfrequency	Utility grid exception. The actual grid frequency exceeds the requirement of the local grid standard.	<p>1. If the problem occurs occasionally, the utility grid may be abnormal temporarily. The inverter will recover automatically after detecting that the utility grid is normal.</p> <p>2. If the problem occurs frequently, check whether the grid frequency is within the permissible range.</p> <ul style="list-style-type: none"> <li>• Contact the local power company if the grid frequency exceeds the permissible range.</li> <li>• Modify the grid overfrequency protection threshold after obtaining the consent of the local power company if the grid frequency is within the permissible range.</li> </ul>



No.	Fault	Cause	Troubleshooting Suggestions
7	Grid Underfrequency	Utility grid exception. The actual grid frequency is lower than the requirement of the local grid standard.	<p>1. If the problem occurs occasionally, the utility grid may be abnormal temporarily. The inverter will recover automatically after detecting that the utility grid is normal.</p> <p>2. If the problem occurs frequently, check whether the grid frequency is within the permissible range.</p> <ul style="list-style-type: none"> <li>• Contact the local power company if the grid frequency exceeds the permissible range.</li> </ul> <p>Modify the grid overfrequency protection threshold after obtaining the consent of the local power company if the grid frequency is within the permissible range.</p>

No.	Fault	Cause	Troubleshooting Suggestions
8	Grid Frequency Unstable	Utility grid exception. The actual grid frequency change rate does not meet the requirement of the local grid standard	<p>1. If the problem occurs occasionally, the utility grid may be abnormal temporarily. The inverter will recover automatically after detecting that the utility grid is normal.</p> <p>2. If the problem occurs frequently, check whether the grid frequency is within the permissible range.</p> <ul style="list-style-type: none"> <li>• Contact the local power company if the grid frequency exceeds the permissible range.</li> <li>• Contact the dealer or the after-sales service if the grid frequency is within the permissible range.</li> </ul>

No.	Fault	Cause	Troubleshooting Suggestions
9	Grid Phase Unstable	Utility grid exception. Grid voltage phase change rates do not meet local grid standards.	<p>1. If the problem occurs occasionally, the utility grid may be abnormal temporarily. The inverter will recover automatically after detecting that the utility grid is normal.</p> <p>2. If the problem occurs frequently, check whether the grid frequency is within the permissible range.</p> <ul style="list-style-type: none"> <li>• Contact the local power company if the grid frequency exceeds the permissible range.</li> <li>• Contact the dealer or the after-sales service if the grid frequency is within the permissible range.</li> </ul>

No.	Fault	Cause	Troubleshooting Suggestions
10	Anti-islanding Protection	The utility grid is disconnected. The utility grid is disconnected according to the safety regulations, but the grid voltage is maintained due to the loads.	<p>1. If the problem occurs occasionally, the utility grid may be abnormal temporarily. The inverter will recover automatically after detecting that the utility grid is normal.</p> <p>2. If the problem occurs frequently, check whether the grid frequency is within the permissible range.</p> <ul style="list-style-type: none"> <li>• Contact the local power company if the grid frequency exceeds the permissible range.</li> <li>• Contact the dealer or the after-sales service if the grid frequency is within the permissible range.</li> </ul>
11	LVRT Undervoltage	Utility grid exception. The duration of the grid voltage abnormality exceeds the time specified for high and low penetration.	

No.	Fault	Cause	Troubleshooting Suggestions
12	HVRT Overvoltage	Utility grid exception. The duration of the grid voltage abnormality exceeds the time specified for high and low penetration.	<ol style="list-style-type: none"> <li>1. If the problem occurs occasionally, the utility grid may be abnormal temporarily. The inverter will recover automatically after detecting that the utility grid is normal.</li> <li>2. If the problem occurs frequently, check whether the voltage and frequency of the power grid are within the permissible range and stable. If no, contact the local power operator; If yes, please contact the local service center.</li> </ol>
13	Grid Waveform Abnormal	Utility grid exception. Abnormal grid voltage detection triggers a fault.	<ol style="list-style-type: none"> <li>1. If the problem occurs occasionally, the utility grid may be abnormal temporarily. The inverter will recover automatically after detecting that the utility grid is normal.</li> </ol>
14	Grid Phase Loss Grid Phase Loss	Utility grid exception. There is a single phase drop in the grid voltage.	<ol style="list-style-type: none"> <li>1. If it occurs frequently, please check whether the voltage and frequency of the power grid are within the permissible range and stable, if not, please contact your local power operator; if yes, please contact your dealer or after-sales service center.</li> </ol>
15	Grid Voltage Imbalance	Excessive differences in grid phase voltages.	<ol style="list-style-type: none"> <li>2. If it occurs frequently, please check whether the voltage and frequency of the power grid are within the permissible range and stable, if not, please contact your local power operator; if yes, please contact your dealer or after-sales service center.</li> </ol>

No.	Fault	Cause	Troubleshooting Suggestions
16	Grid Phase Sequence Abnormal	Abnormal wiring of inverter and grid: wiring out of sequence.	<ol style="list-style-type: none"> <li>1. Check whether the wiring of Inverter and Utility grid is in positive sequence. After the wiring is corrected (e.g., by swapping any two phase wires), the fault will automatically disappear.</li> <li>2. If the wiring is correct and fault persists, please contact the dealer or customer service center.</li> </ol>
17	Grid Rapid Shutdown Protection	Quickly shut down the output upon detecting the grid disconnected operating condition.	<ol style="list-style-type: none"> <li>1. The fault automatically disappears after the grid power supply is restored.</li> </ol>
18	Neutral Line Loss (Split Grid)	Phase separation Utility grid neutral line loss.	<ol style="list-style-type: none"> <li>1. The alarm is automatically cleared after the grid power supply is restored.</li> <li>2. Check whether the AC cable is connected and the AC breaker is on.</li> </ol>
19	EMS/Forced Off-Grid	EMS Issue a forced off-grid command, but the off-grid function is not enabled.	Enable off-grid function

No.	Fault	Cause	Troubleshooting Suggestions
20	GFCI Protection (30mA)	The input insulation impedance becomes low when the inverter is working.	<p>1. If the problem occurs occasionally, it may be caused by a cable exception. The inverter will recover automatically after the problem is solved.</p> <p>2. Check whether the impedance between the PV string and PE is too low if the problem occurs frequently or persists.</p>
21	GFCI Protection (60mA)	The input insulation impedance becomes low when the inverter is working.	<p>1. If the problem occurs occasionally, it may be caused by a cable exception. The inverter will recover automatically after the problem is solved.</p> <p>2. Check whether the impedance between the PV string and PE is too low if the problem occurs frequently or persists.</p>
22	GFCI Protection (150mA)	The input insulation impedance becomes low when the inverter is working.	<p>1. If the problem occurs occasionally, it may be caused by a cable exception. The inverter will recover automatically after the problem is solved.</p> <p>2. Check whether the impedance between the PV string and PE is too low if the problem occurs frequently or persists.</p>

No.	Fault	Cause	Troubleshooting Suggestions
23	GFCI Protection (300mA)	The input insulation impedance becomes low when the inverter is working.	<ol style="list-style-type: none"> <li>1. If the problem occurs occasionally, it may be caused by a cable exception. The inverter will recover automatically after the problem is solved.</li> <li>2. Check whether the impedance between the PV string and PE is too low if the problem occurs frequently or persists.</li> </ol>
24	DCI Protection Level 1	The DC component of the output current exceeds the safety range or default range.	<ol style="list-style-type: none"> <li>1. If the exception is caused by an external fault, the inverter will recover automatically after solving the problem.</li> <li>2. If the problem occurs frequently and the PV station cannot work properly, contact the dealer or the after-sales service.</li> </ol>
25	DCI Protection Level 2	The DC component of the output current exceeds the safety range or default range.	<ol style="list-style-type: none"> <li>1. If the exception is caused by an external fault, the inverter will recover automatically after solving the problem.</li> <li>2. If the problem occurs frequently and the PV station cannot work properly, contact the dealer or the after-sales service.</li> </ol>



No.	Fault	Cause	Troubleshooting Suggestions
26	Low Insulation Resistance	<ol style="list-style-type: none"> <li>1. The PV string is short-circuited to PE.</li> <li>2. The installation environment of PV strings is relatively humid for a long time and the insulation of PE cable is poor.</li> </ol>	<ol style="list-style-type: none"> <li>1. Check the impedance of the PV string to the ground. If there is a short circuit phenomenon, please check the short circuit point and rectify it.</li> <li>2. Check whether the PE cable is connected correctly.</li> <li>3. If it is confirmed that the impedance is indeed lower than the default value in cloudy and rainy days, please reset the "insulation impedance protection value".</li> </ol>
27	Grounding Abnormal	<ol style="list-style-type: none"> <li>1. The PE cable of the inverter is not connected.</li> <li>2. When the output of PV String is grounded, the output side of Inverter is not connected to an isolation transformer.</li> </ol>	<ol style="list-style-type: none"> <li>1. Please confirm if the PE cable of the inverter is properly connected.</li> <li>2. In the scenario where the output of PV String is grounded, please confirm whether an isolation transformer is connected on the output side of Inverter.</li> </ol>
28	L-PE Short Circuit	Output phase line to PE low impedance or short circuit.	Detect output phase line to PE impedance, identify locations with low impedance and repair them.

No.	Fault	Cause	Troubleshooting Suggestions
29	DCV Protection Level 1	Abnormal fluctuation of load	<p>1. If the exception is caused by an external fault, the inverter will recover automatically after solving the problem.</p> <p>2. If the problem occurs frequently and the PV station cannot work properly, contact the dealer or the after-sales service.</p>
30	DCV Protection Level 2	Abnormal fluctuation of load	<p>1. If the exception is caused by an external fault, the inverter will recover automatically after solving the problem.</p> <p>2. If the problem occurs frequently and the PV station cannot work properly, contact the dealer or the after-sales service.</p>
31	Hard Export Limit Protection	Abnormal fluctuation of load	<p>1. If the exception is caused by an external fault, the inverter will recover automatically after solving the problem.</p> <p>2. If the problem occurs frequently and the PV station cannot work properly, contact the dealer or the after-sales service.</p>

No.	Fault	Cause	Troubleshooting Suggestions
32	Internal Comm Loss	Refer to the specific subcode reasons.	Disconnect the AC output side switch and the DC input side switch. After 5 minutes, close the AC output side switch and the DC input side switch. If fault persists, please contact the dealer or after-sales service center.
33	Multiple GFCI Failures	North American safety regulations require multiple failures can not be automatically recovered, you need to manually or wait for 24h recovery	1. Check if the PV String to ground impedance is too low.
34	Multiple AFCI Failures	North American safety regulations require multiple failures can not be automatically recovered, you need to manually or wait for 24h recovery	1. After the machine is re-on-grid, check whether the voltage current of each circuit is abnormally reduced to zero; 2. Check whether the DC side terminal is securely connected.
35	External Comm Loss	Inverter external device communication loss, may be peripheral power supply problems, communication protocol mismatch, not configure the appropriate peripheral, etc..	Judgement is based on the actual model and the detection enable bit, some models do not support the peripheral will not be detected.

No.	Fault	Cause	Troubleshooting Suggestions
36	Back-up Output Overload	1. Prevent the Inverter from continuous overload output.	1. Disconnect some off-grid loads to reduce the off-grid output Power of the inverter.
37	Back-up Output Overvoltage	2. Prevent damage to the load caused by Inverter output overvoltage.	1. If it occurs occasionally, it may be caused by load switching and does not require manual intervention. 2. If the problem occurs frequently, contact the dealer or the after-sales service.
38	On-grid PWM Sync Fault On-grid PWM Sync Fault	Abnormal occurrence in carrier synchronization on-grid.	1. Check if the synchronization line connection is normal. 2. Check whether the master-slave settings are normal. 3. Disconnect the AC output side switch and the DC input side switch. After 5 minutes, close the AC output side switch and the DC input side switch. If fault persists, please contact the dealer or after-sales service center.
39	External Box Failure	Excessive waiting time for Box cut relay when switching on-grid to off-grid	1. Check whether the Box is working properly; 2. Check whether the Box communication wiring is correct;

No.	Fault	Cause	Troubleshooting Suggestions
40	Generator Failure	<p>1. This fault will always be displayed when the generator is not connected.</p> <p>2. During generator operation, failure to meet generator safety regulations will trigger this fault.</p>	<p>1. Ignore the fault when the generator is not connected.</p> <p>2. The occurrence of fault in the generator under fault conditions is normal. After the generator recovers, wait for a period of time, and the fault will automatically clear.</p> <p>3. The fault will not affect the normal operation of the off-grid mode.</p> <p>4. The generator and Utility grid are connected simultaneously and meet the safety requirements, with utility grid taking priority for on-grid, operating in the Utility grid on-grid state.</p>
41	External STS Failure	Inverter and STS connection cable abnormality	Check that the harness connection wire sequence between the inverter and STS corresponds in one-to-one sequence.
42	CT Loss	CT connecting wire disconnection (required by Japanese safety regulations)	1. Check whether the CT wiring is correct;

No.	Fault	Cause	Troubleshooting Suggestions
43	Export Limit Protection	1. Inverter fault reporting and grid disconnection. 2. Meter communication instability. 3. Reverse flow conditions occur.	1. Check if there are any other error messages in Inverter. If so, perform targeted troubleshooting. 2. Check if meter connection is normal. 3. If the problem occurs frequently and the PV station cannot work properly, contact the dealer or the after-sales service.
44	Bypass Over Load		
45	Black Start Failure		
46	Paralell I/O Check Abnormal	Parallel communication cable is not securely connected or parallel operation IO Chip damage	Check whether the parallel communication cable is firmly connected, and then check whether the IO chip is damaged, if so, replace the IO chip.
47	Paralell CAN Comm Abnormal	Parallel communication cable is not securely connected or some units are offline.	Check whether all machines are power on and whether the parallel communication cables are securely connected.
48	Parallel Grid Line Reversed /Paralell Grid Line Reversed	Some machines have grid wires reversed from others.	Rewire the grid.
49	Parallel Back-up Line Reversed	Some machines have backup cables reversed.	Reconnect the backup cable.

No.	Fault	Cause	Troubleshooting Suggestions
50	Inverter Soft Start Failure	Inverter soft start failure during off-grid cold start.	Check machine inverter module for damage.
51	Off grid AC Ins Volt High		
52	AC HCT Check Abnormal	The sampling of the AC HCT is abnormal.	Disconnect the AC output side switch and the DC input side switch. After 5 minutes, close the AC output side switch and the DC input side switch. If fault persists, please contact the dealer or after-sales service center.
53	AC HCT Failure	The sampling of HCT is abnormal.	Disconnect the AC output side switch and the DC input side switch. After 5 minutes, close the AC output side switch and the DC input side switch. If fault persists, please contact the dealer or after-sales service center.
54	GFCI HCT Check Abnormal	The sampling of the GFCI HCT is abnormal.	Disconnect the AC output side switch and the DC input side switch. After 5 minutes, close the AC output side switch and the DC input side switch. If fault persists, please contact the dealer or after-sales service center.
55	GFCI HCT Failure	GFCI HCT is abnormal.	Disconnect the AC output side switch and the DC input side switch. After 5 minutes, close the AC output side switch and the DC input side switch. If fault persists, please contact the dealer or after-sales service center.

No.	Fault	Cause	Troubleshooting Suggestions
56	Relay Check Abnormal	Relay abnormal, reasons are as follows: 1. Relay abnormality (relay short circuit). 2. The relay sampling circuit is abnormal. 3. The AC cable is connected improperly, like a virtual connection or short circuit.	Disconnect the AC output side switch and the DC input side switch. After 5 minutes, close the AC output side switch and the DC input side switch. If fault persists, please contact the dealer or after-sales service center.
57	Relay Failure	1. Relay abnormality (relay short circuit). 2. The relay sampling circuit is abnormal. 3. The AC cable is connected improperly, like a virtual connection or short circuit.	Disconnect the AC output side switch and the DC input side switch. After 5 minutes, close the AC output side switch and the DC input side switch. If fault persists, please contact the dealer or after-sales service center.
58	AFCI Failure (String 17~32)	1. The DC side connection terminal is loose. 2. The DC side connection terminals are falsely connected. 3. The DC cable core breakage and false connection.	1. After the machine is re-on-grid, check whether the voltage current of each circuit is abnormally reduced to zero. 2. Check whether the DC side terminal is securely connected.



No.	Fault	Cause	Troubleshooting Suggestions
59	AFCI Failure (String 33~48)	1. The DC side connection terminal is loose. 2. The DC side connection terminals are falsely connected. 3. The DC cable core breakage and false connection.	1. After the machine is re-on-grid, check whether the voltage current of each circuit is abnormally reduced to zero. 2. Check whether the DC side terminal is securely connected.
60	Flash R/W Abnormal	Causes are possibly as follows: Flash content has changed; flash life is exhausted.	1. Upgrade to the latest version of the program. 2. Contact the dealer or the after-sales service.
61	AFCI Failure (String 1~16)	1. The DC side connection terminal is loose. 2. The DC side connection terminals are falsely connected. 3. The DC cable core breakage and false connection.	1. After the machine is re-on-grid, check whether the voltage current of each circuit is abnormally reduced to zero. 2. Check whether the DC side terminal is securely connected.
62	AFCI Check Failure	The arc-pulling module does not detect an arc-pulling fault during the arc-pulling self-test.	Disconnect the AC output side switch and the DC input side switch. After 5 minutes, close the AC output side switch and the DC input side switch. If fault persists, please contact the dealer or after-sales service center.

No.	Fault	Cause	Troubleshooting Suggestions
63	AC Terminal Overtemperature	<p>AC terminal temperature is too high, causes are possibly as follows:</p> <ol style="list-style-type: none"> <li>1. The inverter is installed in a place with poor ventilation.</li> <li>2. The ambient temperature exceeds 60°C.</li> <li>3. A fault occurs in the internal fan of the inverter.</li> </ol>	<ol style="list-style-type: none"> <li>1. Check whether the ventilation of the inverter installation location is good and whether the ambient temperature exceeds the maximum allowable ambient temperature range.</li> <li>2. If the ventilation is poor or the ambient temperature is too high, please improve the ventilation and heat dissipation conditions.</li> <li>3. Contact the dealer or after-sales service if both the ventilation and the ambient temperature are normal.</li> </ol>
64	Cabinet Overtemperature	<p>Cavity temperature is too high, causes are possibly as follows:</p> <ol style="list-style-type: none"> <li>1. The inverter is installed in a place with poor ventilation.</li> <li>2. The ambient temperature exceeds 60°C.</li> <li>3. A fault occurs in the internal fan of the inverter.</li> </ol>	

No.	Fault	Cause	Troubleshooting Suggestions
65	Inv Module Overtemperature	<p>Inverter module temperature is too high, causes are possibly as follows:</p> <ol style="list-style-type: none"> <li>1. The inverter is installed in a place with poor ventilation.</li> <li>2. The ambient temperature exceeds 60°C.</li> <li>3. A fault occurs in the internal fan of the inverter.</li> </ol>	
66	Boost Module Overtemperature	<p>Boost module temperature is too high, causes are possibly as follows:</p> <ol style="list-style-type: none"> <li>1. The inverter is installed in a place with poor ventilation.</li> <li>2. The ambient temperature exceeds 60°C.</li> <li>3. A fault occurs in the internal fan of the inverter.</li> </ol>	

No.	Fault	Cause	Troubleshooting Suggestions
67	AC Capacitor Overtemperature	<p>Output filter capacitor temperature is too high, causes are possibly as follows:</p> <ol style="list-style-type: none"> <li>1. The inverter is installed in a place with poor ventilation.</li> <li>2. The ambient temperature exceeds 60°C.</li> <li>3. A fault occurs in the internal fan of the inverter.</li> </ol>	
68	Relay Failure 2	<p>Relay abnormal, reasons are as follows:</p> <ol style="list-style-type: none"> <li>1. Relay abnormality (relay short circuit).</li> <li>2. The relay sampling circuit is abnormal.</li> <li>3. The AC cable is connected improperly, like a virtual connection or short circuit.</li> </ol>	<p>Disconnect the AC output side switch and the DC input side switch. After 5 minutes, close the AC output side switch and the DC input side switch. If fault persists, please contact the dealer or after-sales service center.</p>

No.	Fault	Cause	Troubleshooting Suggestions
69	PV IGBT Short Circuit	Causes are possibly as follows: 1. IGBT short circuit. 2. The inverter sampling circuit is abnormal.	Disconnect the AC output side switch and the DC input side switch. After 5 minutes, close the AC output side switch and the DC input side switch. If fault persists, please contact the dealer or after-sales service center.
70	PV IGBT Open Circuit	1. A software problem caused the wave not to be sent. 2. The drive circuit is abnormal. 3. IGBT open circuit	Disconnect the AC output side switch and the DC input side switch. After 5 minutes, close the AC output side switch and the DC input side switch. If fault persists, please contact the dealer or after-sales service center.
71	NTC Abnormal	Abnormal NTC temperature sensor	Disconnect the AC output side switch and the DC input side switch. After 5 minutes, close the AC output side switch and the DC input side switch. If fault persists, please contact the dealer or after-sales service center.
72	PWM Abnormal	Abnormal waveform appears in PWM	Disconnect the AC output side switch and the DC input side switch. After 5 minutes, close the AC output side switch and the DC input side switch. If fault persists, please contact the dealer or after-sales service center.

No.	Fault	Cause	Troubleshooting Suggestions
73	CPU Interrupt Abnormal	CPU Interruption anomaly occurs.	Disconnect the AC output side switch and the DC input side switch. After 5 minutes, close the AC output side switch and the DC input side switch. If fault persists, please contact the dealer or after-sales service center.
74	Microelectronic Failure	Functional safety detects an anomaly.	Disconnect the AC output side switch and the DC input side switch. After 5 minutes, close the AC output side switch and the DC input side switch. If fault persists, please contact the dealer or after-sales service center.
75	PV HCT Failure	Abnormal boost current sensor.	Disconnect the AC output side switch and the DC input side switch. After 5 minutes, close the AC output side switch and the DC input side switch. If fault persists, please contact the dealer or after-sales service center.
76	1.5V Ref Abnormal	The reference circuit is abnormal.	Disconnect the AC output side switch and the DC input side switch. After 5 minutes, close the AC output side switch and the DC input side switch. If fault persists, please contact the dealer or after-sales service center.
77	0.3V Ref Abnormal	The reference circuit is abnormal.	

No.	Fault	Cause	Troubleshooting Suggestions
78	CPLD Version Error	CPLD version identification error.	Disconnect the AC output side switch and the DC input side switch. After 5 minutes, close the AC output side switch and the DC input side switch. If fault persists, please contact the dealer or after-sales service center.
79	CPLD Comm Failure	CPLD and DSP communication content error or timeout.	Disconnect the AC output side switch and the DC input side switch. After 5 minutes, close the AC output side switch and the DC input side switch. If fault persists, please contact the dealer or after-sales service center.
80	Model Type Error	Troubleshooting about model recognition error.	Disconnect the AC output side switch and the DC input side switch. After 5 minutes, close the AC output side switch and the DC input side switch. If fault persists, please contact the dealer or after-sales service center.
81	SVG Precharge Failure	SVG Precharge hardware failure.	Contact the dealer or the after-sales service.
82	SVG Mode PID Prevention Failure	PID prevent hardware anomaly.	Contact the dealer or the after-sales service.
83	DSP Version Error	DSP version identification error.	Disconnect the AC output side switch and the DC input side switch. After 5 minutes, close the AC output side switch and the DC input side switch. If fault persists, please contact the dealer or after-sales service center.

No.	Fault	Cause	Troubleshooting Suggestions
84	BUS Overvoltage	<p>BUS overvoltage. Causes are possibly as follows:</p> <ol style="list-style-type: none"> <li>1. The PV voltage is too high.</li> <li>2. The sampling of the inverter BUS voltage is abnormal.</li> <li>3. The isolation of the transformer of the inverter is poor, so two inverters influence each other when connected to the grid. One of the inverters reports DC overvoltage.</li> </ol>	<p>Disconnect the AC output side switch and the DC input side switch. After 5 minutes, close the AC output side switch and the DC input side switch. If fault persists, please contact the dealer or after-sales service center.</p>
85	P-BUS Overvoltage		
86	N-BUS Overvoltage		
87	BUS Overvoltage (Slave CPU 1) BUS/Overvoltage(Slave CPU 1)		
88	P-BUS Overvoltage (Slave CPU 1)		
89	N-BUS Overvoltage (Slave CPU 1)		
90	BUS Overvoltage (Slave CPU 2)		
91	P-BUS Overvoltage (Slave CPU 2)		
92	N-BUS Overvoltage (Slave CPU 2)		
93	P-BUS Overvoltage (CPLD)		
94	N-BUS Overvoltage (CPLD)		



No.	Fault	Cause	Troubleshooting Suggestions
95	MOS Continuous Overvoltage	<ol style="list-style-type: none"> <li>1. Software issue causes the inverter drive to shut down earlier than the flyback drive.</li> <li>2. Inverter drive circuit abnormality causes failure to turn on.</li> <li>3. The PV voltage is too high.</li> <li>4. Mos sampling anomaly.</li> </ol>	<p>Disconnect the AC output side switch and the DC input side switch. After 5 minutes, close the AC output side switch and the DC input side switch. If fault persists, please contact the dealer or after-sales service center.</p>
96	Bus Short Circuit	<ol style="list-style-type: none"> <li>1. The hardware is damaged.</li> </ol>	<p>If the inverter continues to be off-grid after a BUS short-circuit fault occurs, please contact your dealer or after-sales service center.</p>
97	Bus Sample Abnormal	<ol style="list-style-type: none"> <li>1. Bus voltage sampling hardware failure.</li> </ol>	<p>Disconnect the AC output side switch and the DC input side switch. After 5 minutes, close the AC output side switch and the DC input side switch. If fault persists, please contact the dealer or after-sales service center.</p>
98	DC Sample Abnormal	<ol style="list-style-type: none"> <li>1. Bus voltage sampling hardware failure.</li> <li>2. Battery voltage sampling hardware failure.</li> <li>3. Dcrlly relay failure.</li> </ol>	<p>Disconnect the AC output side switch and the DC input side switch. After 5 minutes, close the AC output side switch and the DC input side switch. If fault persists, please contact the dealer or after-sales service center.</p>

No.	Fault	Cause	Troubleshooting Suggestions
99	PV Input Overvoltage	PV input voltage is too high. Causes are possibly as follows: Incorrect photovoltaic array configuration, with too many PV Battery panels connected in series in the string, causing the string's open-circuit voltage to exceed the maximum operating voltage of the Inverter.	Check the serial connection of the PV array. Make sure that the open circuit voltage of the PV string is not higher than the maximum operating voltage of the inverter. The inverter alarm disappears automatically when the PV array is configured correctly.
100	PV Continuous Hardware Overcurrent	1. The PV configuration is not proper. 2. The hardware is damaged.	Disconnect the AC output side switch and the DC input side switch. After 5 minutes, close the AC output side switch and the DC input side switch. If fault persists, please contact the dealer or after-sales service center.
101	PV Continuous Software Overcurrent	1. The module configuration is not proper. 2. The hardware is damaged.	
102	FlyCap Software Overvoltage	FlyCap overvoltage. Causes are possibly as follows: 1. The PV voltage is too high. 2. The sampling of the inverter FlyCap voltage is abnormal.	Disconnect the AC output side switch and the DC input side switch. After 5 minutes, close the AC output side switch and the DC input side switch. If fault persists, please contact the dealer or after-sales service center.

No.	Fault	Cause	Troubleshooting Suggestions
103	FlyCap Hardware Overvoltage	FlyCap overvoltage. Causes are possibly as follows: 1. The PV voltage is too high. 2. The sampling of the inverter FlyCap voltage is abnormal.	
104	FlyCap Undervoltage	FlyCap undervoltage. Causes are possibly as follows: 1. PV Energy deficit; 2. The sampling of the inverter FlyCap voltage is abnormal.	
105	FlyCap Precharge Failure	FlyCap precharge failure. Causes are possibly as follows: 1. PV Energy deficit; 2. The sampling of the inverter FlyCap voltage is abnormal.	
106	FlyCap Precharge Abnormal	1. Unreasonable control loop parameters 2. The hardware is damaged.	

No.	Fault	Cause	Troubleshooting Suggestions
107	PV String Overcurrent (String 1~16)	Causes are possibly as follows: 1. String overcurrent. 2. String current sensor abnormality.	
108	PV String Overcurrent (String 17~32)	As above.	
109	PV String Reversed (String 1~16)	The PV strings are connected reversely.	Check whether PV strings are connected reversely.
110	PV String Reversed (String 17~32)	The PV strings are connected reversely.	Check whether PV strings are connected reversely.
111	PV String Loss (String 1~16)	String fuse disconnected (if applicable).	Check if the fuse is blown.
112	PV String Loss (String 17~32)	String fuse disconnected (if applicable).	Check if the fuse is blown.

No.	Fault	Cause	Troubleshooting Suggestions
113	PV Input Mode Error	<p>There are three modes of PV access modes, taking the four-way MPPT as an example:</p> <ol style="list-style-type: none"> <li>1. Parallel mode: i.e. AAAA mode (homogenous mode), PV1-PV4 homogenous, four-way PV connected to the same PV panel.</li> <li>2. Partial parallel mode: i.e. AACC mode, PV1 and PV2 are connected in the same source, PV3 and PV4 are connected in the same source.</li> <li>3. Independent mode: i.e. ABCD mode (non-homologous), PV1, PV2, PV3, PV4 are connected independently, and each of the four-way PV is connected to a photovoltaic panel.</li> </ol> <p>This fault is reported if the actual access mode of the PV does not match the PV</p>	<p>Check that the PV access mode is set correctly (ABCD, AACC, AAAA) and reset the PV access mode in the correct way.</p> <ol style="list-style-type: none"> <li>1. Confirm that the actual access to each PV is properly connected.</li> <li>2. If the PV has been connected correctly, check whether the currently set "PV Access Mode" corresponds to the actual access mode through APP or screen.</li> <li>3. If the currently set "PV access mode" does not match the actual access mode, you need to set the "PV access mode" to a mode that matches the actual situation through APP or screen, and then disconnect the PV and AC power supply and restart after the setup is completed.</li> <li>4. After the setting is completed, if the current "PV access mode" is consistent with the actual access mode, but this fault is still reported, please contact the dealer or after-sales service center.</li> </ol>

No.	Fault	Cause	Troubleshooting Suggestions
		access mode set by the device.	
114	PV String Reversed (String 33~48)	The PV strings are connected reversely.	Check whether PV strings are connected reversely.
115	PV String Loss (String 33~48)	String fuse disconnected (if applicable).	Check if the fuse is blown. As above.
116	PV String Overcurrent (String 33~48)	Causes are possibly as follows: 1. String overcurrent. 2. String current sensor abnormality.	
117	BAT 1 Precharge Failure	Battery 1 precharge circuit failure (burnt precharge resistor, etc.)	Check whether the pre-charging circuit is good, whether the battery voltage and bus voltage are consistent after powering up the battery only, if not, please contact the dealer or after-sales service center.

No.	Fault	Cause	Troubleshooting Suggestions
118	BAT 1 Relay Failure	Battery 1 relay does not operate properly.	After the battery is powered up, check if the battery relay works and if you hear a closing sound, if it does not work, please contact your dealer or after-sales service center.
119	BAT 1 Overvoltage	Battery 1 access voltage exceeds the rated range of the machine.	Verify that the battery voltage is within the rated range of the machine.
120	BAT 2 Precharge Failure	Battery 2 precharge circuit failure (burnt precharge resistor, etc.)	Check whether the pre-charging circuit is good, whether the battery voltage and bus voltage are consistent after powering up the battery only, if not, please contact the dealer or after-sales service center.
121	BAT 2 Relay Failure	Battery 2 relay does not operate properly.	After the battery is powered up, check if the battery relay works and if you hear a closing sound, if it does not work, please contact your dealer or after-sales service center.
122	BAT 2 Overvoltage	Battery 2 access voltage exceeds the rated range of the machine.	Verify that the battery voltage is within the rated range of the machine.
123	BAT 1 Reversed	Positive and negative poles of Battery 1 are connected reversely.	Check the battery and machine terminals for positive and negative consistency.

No.	Fault	Cause	Troubleshooting Suggestions
124	BAT 2 Reversed	Battery 2 positive and negative are connected reversely.	Check the battery and machine terminals for positive and negative consistency.
125	BAT Connection Abnormal	Battery abnormal connection.	Check whether the battery is working properly.
125	Bat Overtemperature	Battery temperature is too high. Causes are possibly as follows: 1. The inverter is installed in a place with poor ventilation. 2. The ambient temperature exceeds 60°C. 3. A fault occurs in the internal fan of the inverter.	
127	Ref Voltage Abnormal	The reference circuit is abnormal.	Disconnect the AC output side switch and the DC input side switch. After 5 minutes, close the AC output side switch and the DC input side switch. If fault persists, please contact the dealer or after-sales service center.
128	AC SPD Fault	AC side lightning protection device failure.	Replace AC side lightning protection devices.
129	DC SPD Fault	DC side lightning protection device failure.	Replace DC side lightning protection devices.



No.	Fault	Cause	Troubleshooting Suggestions
130	Internal Fan Abnormal	Internal fan abnormality. Causes are possibly as follows: 1. Abnormal fan power supply. 2. Mechanical exception (blocking). 3. Fan aging damage.	Disconnect the AC output side switch and the DC input side switch. After 5 minutes, close the AC output side switch and the DC input side switch. If fault persists, please contact the dealer or after-sales service center.
131	External Fan Abnormal	External fan abnormality. Causes are possibly as follows: 1. Abnormal fan power supply. 2. Mechanical exception (blocking). 3. Fan aging damage.	
132	PID Abnormal	PID hardware failure or high PV voltage PID pause.	PID pause warning caused by high PV voltage does not need to be dealt with, PID hardware failure can be cleared by turning the PID switch off and on again to clear the PID fault, replace the PID unit.

No.	Fault	Cause	Troubleshooting Suggestions
133	Trip-Switch Trip Warning	<p>Causes are possibly as follows:</p> <ol style="list-style-type: none"> <li>1. An overcurrent or PV reversal has occurred causing the disconnect switch to trip;</li> </ol>	<p>Contact the dealer or the after-sales service. The reason for disconnection, for the occurrence of PV short circuit or reverse connection, it is necessary to check whether there is a historical PV short circuit warning or historical PV reverse connection warning, and if there is, it is necessary for the maintenance personnel to check the corresponding PV situation. After checking that there are no faults you can manually close the disconnect switch and clear this warning via the APP interface clear history faults operation.</p>
134	PV IGBT Short Circuit Warning	<p>Causes are possibly as follows:</p> <ol style="list-style-type: none"> <li>1. An overcurrent occurs causing the disconnect switch to trip.</li> </ol>	<p>Contact the dealer or the after-sales service. Maintenance personnel need to follow the historical PV short circuit warning sub-code to check whether there is any fault in the short-circuited Boost hardware and external strings; after checking there is no fault, the warning can be cleared by clearing the historical fault operation through the APP interface.</p>

No.	Fault	Cause	Troubleshooting Suggestions
135	PV String Reversed Warning(String 1~16)	<p>Causes are possibly as follows:</p> <p>1. The PV reverse connection has occurred causing the disconnecting switch to trip;</p>	<p>Contact the dealer or the after-sales service. Maintenance personnel need to follow the historical PV reverse connection warning subcode to check whether the corresponding string is reverse connected and whether there is pressure difference in the PV panel configuration; after the check is complete and there is no fault, the warning can be cleared by clearing the historical fault operation through the APP interface.</p>
136	PV String Reversed Warning (String 17~32)	<p>Causes are possibly as follows:</p> <p>1. The PV reverse connection has occurred causing the disconnecting switch to trip;</p>	<p>Contact the dealer or the after-sales service. Maintenance personnel need to follow the historical PV reverse connection warning subcode to check whether the corresponding string is reverse connected and whether there is pressure difference in the PV panel configuration; after the check is complete and there is no fault, the warning can be cleared by clearing the historical fault operation through the APP interface.</p>

No.	Fault	Cause	Troubleshooting Suggestions
137	Flash R/W Error Flash R/W Error	Causes are possibly as follows: Flash content has changed; flash life is exhausted.	1. Upgrade the latest version of the program. 2. Contact the dealer or the after-sales service.
138	Meter Comm Loss	This warning may be reported only after enabling the anti-reverse flow function. Causes are possibly as follows: 1. Meter not connected. 2. The communication wire connecting the meter to the inverter is wired incorrectly.	Check the wiring of the meter and connect the meter correctly, if the fault still exists after checking, contact the dealer or the after-sales service.
139	PV Type Identification Failure	PV panel recognizes hardware anomaly.	Contact the dealer or the after-sales service.
140	PV String Mismatch	PV string mismatches. Two sets of string open-circuit voltages under the same MPPT have different configurations.	Check the open-circuit voltage of the two strings, and configure the strings with the same open-circuit voltage under the same MPPT, as long time string mismatch is a potential safety hazard.
141	CT Loss	CT Loss	Check whether the CT wiring is correct.
142	CT Reversed	CT Reversed	Check whether the CT wiring is correct.
143	PE Loss	Ground wire not connected.	Check the ground wire.

No.	Fault	Cause	Troubleshooting Suggestions
144	PV String Terminal Overtemperature (String 1~8)	37176 Register PV Terminal Temperature Alarm Subcode 1 has a set position.	
145	PV String Terminal Overtemperature (String 9~16)	37177 Register PV Terminal Temperature Alarm Subcode 2 has a set position.	
146	PV String Terminal Overtemperature (String 17~20)	37178 Register PV Terminal Temperature Alarm Subcode 3 has a set position.	
147	PV String Reversed Warning (String 33~48)	<p>Causes are possibly as follows:</p> <ol style="list-style-type: none"> <li>1. The PV reverse connection has occurred causing the disconnecting switch to trip.</li> </ol>	<p>Contact the distributor or after-sales service center; Maintenance personnel need to follow the historical PV reverse connection warning subcode to check whether the corresponding string is reverse connected and whether there is pressure difference in the PV panel configuration; after the check is complete and there is no fault, the warning can be cleared by clearing the historical fault operation through the APP interface.</p>
148	Battery 1 Low Voltage	Battery voltage below set value.	
149	Battery 2 Low Voltage	Battery voltage below set value.	

No.	Fault	Cause	Troubleshooting Suggestions
150	Low Battery Supply Voltage	When the battery is in non-charging mode, the voltage is lower than the shutdown voltage.	

### 11.5.2.3 Battery Fault (LX A5.0-10)

● When the battery ALM indicator turns red, troubleshoot the issue by referring to the SOC indicator's display status.

No.	SOC Indicator	Fault	Solutions/measures to address the issue
1	○○○○●	Battery Overvoltage	Power off and wait for 2 hours. If the problem persists, please contact the after-sales service.
2	○○○●○	Battery Undervoltage	Contact the after-sales service.
3	○○○●●	High Cell Temperature	Power off and wait for 2 hours. If the problem persists, please contact the after-sales service.
4	○○●○○	Low Charging Temperature	Turn off the device to wait for the temperature to return to normal. If the problem persists after restarting, please contact the after-sales service center.
5	○○●●●	Low Discharging Temperature	Turn off the device to wait for the temperature to return to normal. If the problem persists after restarting, please contact the after-sales service center.
6	○○●●○	Overcurrent Charging	Restart the battery. If the problem persists after restarting, please contact the after-sales service center.
7	○○●●●	Overcurrent Discharging	Restart the battery. If the problem persists after restarting, please contact the after-sales service center.
8	○●○○○	Low Insulation Resistance	Contact the after-sales service.

No.	SOC Indicator	Fault	Solutions/measures to address the issue
9	○○○○●	Excessive Temperature Difference	Power off and wait for 2 hours. If the problem persists, please contact the after-sales service.
10	○○○○●	Voltage Difference Exception	Leave the battery alone for 12h after restarting. If the problem persists, please contact the after-sales service center.
11	○○●○○	Inconsistency of Battery Cells	Contact the after-sales service.
12	○○●○○	Wire Harness Exception	Restart the battery. If the problem persists after restarting, please contact the after-sales service center.
13	○○●●○○	MOS Open-Circuit Fault	Restart the battery. If the problem persists after restarting, please contact the after-sales service center.
14	○○●●●○	MOS Open-Circuit Fault	Restart the battery. If the problem persists after restarting, please contact the after-sales service center.
15	●○○○○	Cluster Fault	Please check if the battery model matches. If not, please contact the after-sales service center.
16	●○○○○●	Interlock Failure	Check whether the termination resistor is installed properly and restart the battery. Contact the after-sale service if the problem persists.
17	●○○●○○	BMU Communication Fault	Restart the battery. If the problem persists after restarting, please contact the after-sales service center.
18	●○○●●○	MCU Communication Fault	Restart the battery. If the problem persists after restarting, please contact the after-sales service center.
19	●○○○○	Open Contact Sticking Fault	Contact the after-sales service.
20	●○○○○●	Precharge Failure	Restart the battery. If the problem persists after restarting, please contact the after-sales service center.

No.	SOC Indicator	Fault	Solutions/measures to address the issue
21	●○○●○○	MOS Over-temperature Fault	Power off and wait for 2 hours. If the problem persists, please contact the after-sales service.
22	●○○●●●	Current Diverter Over-temperature	Power off and wait for 2 hours. If the problem persists, please contact the after-sales service.
23	●●○○○○	Reverse Connection Fault	Contact the after-sales service.
24	●●●●●●	Microelectronic Fault	Contact the after sales service.





#### 11.5.2.4 Battery Fault (LX A5.0-30, LX U5.0-30)

Alarm state

● When the battery ALM indicator turns red, troubleshoot the issue by referring to the SOC indicator's display status.

No.	SOC Indicator	Fault	Solutions/measures to address the issue
1	○○○●	Battery overvoltage protection Battery undervoltage protection	<ol style="list-style-type: none"> <li>1. Check whether the Charging Current Limit of the inverter is 0 through SolarGo. If yes, please confirm whether the communication cable connection between the battery and the inverter is reliable and the communication is normal.</li> <li>2. Power off and wait for 5 minutes, then restart to confirm if the fault persists.</li> <li>3. If the fault is not restored, please contact the after-sales service center.</li> </ol>





No.	SOC Indicator	Fault	Solutions/measures to address the issue
2		Overcurrent Protection	<ol style="list-style-type: none"> <li>1. Check if the battery model is correct through SolarGo and confirm if the real-time current of the battery is greater than the Charging/Discharging Current Limit. Please contact the after-sales service center.</li> <li>2. When it is less than the Charging/Discharging Current Limit., turn off the battery or upgrade the program, restart to confirm whether the fault persists.</li> <li>3. If the fault is not restored, please contact the after-sales service center.</li> </ol>
3		Over temperature protection Low temperature protection Pole over temperature protection	Power off and wait for 60 minutes, wait for the temperature to recover. If the problem persists after restarting, please contact the after-sales service center.
4		Balancing Fault Low SOH Fault	Power off and wait for 30 minutes. If the problem persists after restarting, please contact the after-sales service center.
5		Precharge Failure	<ol style="list-style-type: none"> <li>1. Confirm if the battery output terminal is connected in reverse to the inverter.</li> <li>2. Power off and wait for 30 minutes. If the problem persists after restarting, please contact the after-sales service center.</li> </ol>
6		Wire Harness Exception	Confirm if the battery switch is closed. If the battery switch is closed and the problem still exists. Please contact the after-sales service center.



No.	SOC Indicator	Fault	Solutions/measures to address the issue
7	●●○○	Relay or MOS over Temperature Diverter over Temperature	Power off and wait for 30 minutes. If the problem persists after restarting, please contact the after-sales service center.
		Other BMS Faults: Output Port over Temperature Fault	1. Check if the battery power cable is connected tightly.  Power off and wait for 5 minutes. If the problem persists after restarting, please contact the after-sales service center.
8	○●●○	Other Protections: MOS cannot be Closed	Power off and wait for 5 minutes. If the problem persists after restarting, please contact the after-sales service center.
9	○●●●	Other Protections: MOS Adhesion	
10	●○○○	Other Protections: Cluster Fault	1. Confirm whether the type and installation position of the terminal resistor used are correct. 2. Confirm whether the communication cable between batteries, the cable between batteries and inverters are reliable and the communication is normal. 3. If the fault is not restored, please contact the after-sales service center.
11	○○○○	Other Protections: Communication Loss with Inverter	1. Confirm whether the communication cable between batteries, the cable between batteries and inverters are reliable and the communication is normal. 2. If the fault is not restored, please contact the after-sales service center.



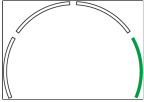
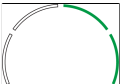
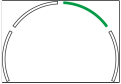

No.	SOC Indicator	Fault	Solutions/measures to address the issue
12	● ○ ○ ●	Other Protections: BMU Communication Failure	<ol style="list-style-type: none"> <li>1. Confirm whether the type and installation position of the terminal resistor used are correct.</li> <li>2. Confirm whether the communication cable between batteries, the cable between batteries and inverters are reliable and the communication is normal.</li> <li>3. Power off and wait for 5 minutes. If the problem persists after restarting, please contact the after-sales service center.</li> </ol>
13	● ○ ● ○	Other Protections: Air Switch Adhesion Fault	Power off and wait for 5 minutes. If the problem persists after restarting, please contact the after-sales service center.
14	● ● ○ ●	Other Protections: Software Fault	Restart the battery. If the problem persists after restarting, please contact the after-sales service center.
15	● ● ● ○	Other Protections: Hardware Overcurrent Fault	
16	● ● ● ●	Other Protections: Microelectronics Fault	
		Heating Film Abnormal	<ol style="list-style-type: none"> <li>1. Upgrade software</li> <li>2. Power off and wait for 5 minutes. If the problem persists after restarting, please contact the after-sales service center.</li> </ol>

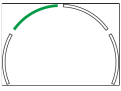
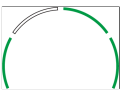
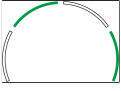
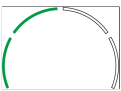
### 11.5.2.5 Battery Fault (GW14.3-BAT-LV-G10)

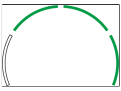
When the battery alarm indicator light turns red , the outer marquee flashes  red, and the operation light turns off, combine the SOC indicator light display status to locate and troubleshoot the fault.

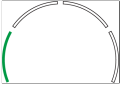
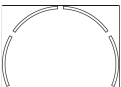
No.	SOC Indicator	Fault	Solutions/measures to address the issue
1		Battery Overvoltage Protection	<ol style="list-style-type: none"> <li>1. Check whether the inverter charging current limit is 0 via SolarGo. If it is 0, confirm that the communication line between the battery and the inverter is connected reliably and that communication is normal.</li> <li>2. Shut down and leave for 5 minutes, then restart and confirm whether the fault persists.</li> <li>3. If the fault is not restored, please contact the after-sales service center.</li> </ol>
		Battery Undervoltage Protection	
2		Overcurrent Protection	<ol style="list-style-type: none"> <li>1. Check the battery model through SolarGo to confirm whether the real-time current of the battery is greater than the charging current limit or discharge current limit value. If so, please contact the after-sales service center.</li> <li>2. If the current is less than the limit, shut down the battery or upgrade the program, then restart to confirm whether the fault persists.</li> <li>3. If the fault is not resolved, please contact after-sales service.</li> </ol>
3		Over Temperature Protection	Power off and wait for 60 minutes, wait for the temperature to recover. If the problem persists after restarting, please contact the after-sales service center.
		Low Temperature Protection	

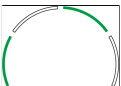
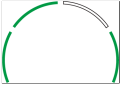
		Pole over Temperature Protection	
4		Balancing Fault	Power off and wait for 30 minutes. If the problem persists after restarting, please contact the after-sales service center.
		Low SOH Fault	
5		Precharge Failure	<ol style="list-style-type: none"> <li>1. Check whether the battery output terminal is connected to the inverter in reverse.</li> <li>2. Shut down and wait for 5 minutes. If the problem persists after restarting, please contact the after-sales service center.</li> </ol>
6		Wire Harness Exception	Check whether the battery circuit breaker is closed. If the battery circuit breaker is closed and the problem persists, please contact the after-sales service center.
7		Relay or MOS over Temperature	Power off and wait for 30 minutes. If the problem persists after restarting, please contact the after-sales service center.
		Output Port Overheating	<ol style="list-style-type: none"> <li>1. Check whether the battery power cord is securely connected.</li> <li>2. Turn off the device and leave it for 5 minutes. If the problem persists after restarting, please contact the after-sales service center.</li> </ol>
8		MOS Open-Circuit Fault	Power off and wait for 5 minutes. If the problem persists after restarting, please contact the after-sales service center.
9		MOS Adhesion	

10		Cluster Fault	<ol style="list-style-type: none"> <li>1. Confirm that the type and installation location of the terminal resistor are correct.</li> <li>2. Confirm that the communication lines between batteries and between batteries and inverters are connected reliably and that communication is normal.</li> <li>3. If the fault persists, please contact the after-sales service center.</li> </ol>
11		Inconsistent Software and Hardware Versions	Restart the battery. If the problem persists after restarting, please contact the after-sales service center.
12		BMU Communication Fault	
13		Open Contact Sticking Fault	Power off and wait for 5 minutes. If the problem persists after restarting, please contact the after-sales service center.
14		Software Fault	Restart the battery. If the problem persists after restarting, please contact the after-sales service center.
15		Hardware Overcurrent Fault	
		Microelectronic Fault	
16		Heating Film Abnormal	<ol style="list-style-type: none"> <li>1. Upgrade the software.</li> <li>2. Shut down the computer and leave it idle for 5 minutes. If the problem persists after restarting, please contact the after-sales service center.</li> </ol>

### 11.5.3 Operation After Fault Clearance

In the energy conservation system, after some fault clearances complete, further operations are needed for the system to restore normal work.

#### 11.5.3.1 Clear AFCI Alarm

[Software]: SolarGo App  
[Clearance method]

1. Home > Settings > Advanced Settings > DC AFCI
2. Tap [Clear AFCI Alarm].

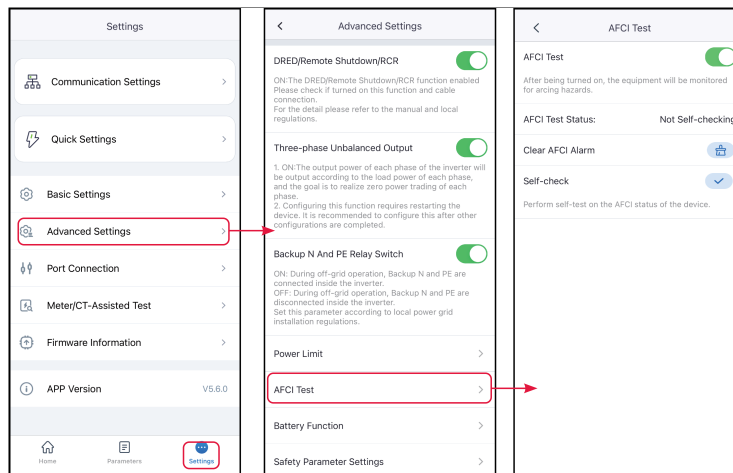

## 12 Technical Parameters

### 12.1 Inverter Parameters

Technical Data	GW3000-ES-C10	GW3600-ES-C10	GW5000-ES-C10	GW6000-ES-C10
Battery Input Data				
Battery Type*1	Li-Ion/Lead-acid	Li-Ion/Lead-acid	Li-Ion/Lead-acid	Li-Ion/Lead-acid
Nominal Battery Voltage (V)	48	48	48	48
Battery Voltage Range (V)	40~60	40~60	40~60	40~60
Start-up Voltage (V)	44.2	44.2	44.2	44.2
Number of Battery Input	1	1	1	1
Max. Continuous Charging Current (A)	70	90	120	140
Max. Continuous Discharging Current (A)	70	90	120	140
Max. Charge Power (kW)	3.0*2	3.6*2	5.0*2	6.0*2
Max. Discharge Power (kW)	3.3*2	3.96*2	5.5*2	6.6*2
PV String Input Data				
Max. Input Power (kW)	6.0	7.2	10.0	12.0
Max. Input Voltage (V)*4	600	600	600	600



MPPT Operating Voltage Range (V) <sup>*5</sup>	60~550	60~550	60~550	60~550
MPPT Voltage Range at Nominal Power (V)	180~500	120~500	150~500	180~500
Start-up Voltage (V)	58	58	58	58
Nominal Input Voltage (V)	360	360	360	360
Max. Input Current per MPPT (A)	20	20	20	20
Max. Short Circuit Current per MPPT (A)	26	26	26	26
Max. Backfeed Current to The Array (A)	0	0	0	0
Number of MPPT Trackers	1	2	2	2
Number of Strings per MPPT	1	1	1	1
AC Output Data (On-grid)				
Nominal Output Power (kW)	3.0	3.6	5.0	6.0
Nominal Apparent Power Output to Utility Grid (VA)	3.0	3.6	5.0	6.0
Max. AC Active Power (W) <sup>*7*8</sup>	3.3	3.96 <sup>*10</sup>	5.5	6.6

Max. Apparent Power Output to Utility Grid (VA) <sup>*7*8</sup>	3.3	3.96 <sup>*10</sup>	5.5	6.6
Nominal Power at 40°C (W)	3.0	3.6	5.0	6.0
Max. Power at 40°C (Including AC Overload) (W) <sup>*8</sup>	3.0	3.6	5.0	6.0
Nominal Apparent Power from Utility Grid (VA)	3.0	3.6	5.0	6.0
Max. Apparent Power from Utility Grid (kVA)	7.04	7.04	8.8	8.8
Nominal Power at 40°C (kW)	3.0	3.6	5.0	6.0
Max. Power at 40°C (Including AC Overload) (kW)	3.0	3.6	5.0	6.0
Nominal Output Voltage (V)	220/230/240	220/230/240	220/230/240	220/230/240
Output Voltage Range (V)	170~280	170~280	170~280	170~280

Nominal AC Grid Frequency (Hz)	50/60	50/60	50/60	50/60
AC Grid Frequency Range (Hz)	45~55/55~65	45~55/55~65	45~55/55~65	45~55/55~65
Max. AC Current Output to Utility Grid (A)	15.0	18.0*9	25.0	30.0
Max. AC Current From Utility Grid (A)	32.0	32.0	40.0	40.0
Nominal AC Current From Utility Grid (A)	13.7 at 220V 13.1 at 230V 12.5 at 240V	16.4 at 220V 15.7 at 230V 15.0 at 240V	22.8 at 220V 21.8 at 230V 20.9 at 240V	27.3 at 220V 26.1 at 230V 25.0 at 240V
Max. Output Fault Current (Peak and Duration) (A)	96A, 3 $\mu$ s	96A, 3 $\mu$ s	96A, 3 $\mu$ s	96A, 3 $\mu$ s
Inrush Current (Peak and Duration) (A)	96A, 3 $\mu$ s	96A, 3 $\mu$ s	96A, 3 $\mu$ s	96A, 3 $\mu$ s
Nominal Output Current (A)	13.7 at 220V 13.1 at 230V 12.5 at 240V	16.4 at 220V 15.7 at 230V 15.0 at 240V	22.8 at 220V 21.8 at 230V 20.9 at 240V	27.3 at 220V 26.1 at 230V 25.0 at 240V
Power Factor	~1 (Adjustable from 0.8 leading to 0.8 lagging)	~1 (Adjustable from 0.8 leading to 0.8 lagging)	~1 (Adjustable from 0.8 leading to 0.8 lagging)	~1 (Adjustable from 0.8 leading to 0.8 lagging)
Max. Total Harmonic Distortion	<3%	<3%	<3%	<3%

Maximum Output Overcurrent Protection (A)	53	53	88	88
Type of Voltage (a.c. or d.c.)	a.c.	a.c.	a.c.	a.c.
AC Output Data (Back-up)				
Back-up Nominal Apparent Power (kVA)	3.0	3.6	5.0	6.0
Max. Output Apparent Power without Grid(kVA)	3.3(6.0, 10s)	3.96(7.2, 10s)	5.5(10.0, 10s)	6.6(12.0, 10s)
Max. Output Apparent Power with Grid (kVA)	7.04	7.04	8.8	8.8
Nominal Output Current (A)	13.7 at 220V 13.1 at 230V 12.5 at 240V	16.4 at 220V 15.7 at 230V 15.0 at 240V	22.8 at 220V 21.8 at 230V 20.9 at 240V	27.3 at 220V 26.1 at 230V 25.0 at 240V
Max. Output Current without Grid(A)	15	18	25	30
Max. Output Current with Grid(A)	32	32	40	40
Max. Output Fault Current (Peak and Duration) (A)	96A, 3 $\mu$ s	96A, 3 $\mu$ s	96A, 3 $\mu$ s	96A, 3 $\mu$ s
Inrush Current (Peak and Duration) (A)	96A, 3 $\mu$ s	96A, 3 $\mu$ s	96A, 3 $\mu$ s	96A, 3 $\mu$ s

Maximum Output Overcurrent Protection (A)	53	53	88	88
Nominal Output Voltage (V)	220/230/240	220/230/240	220/230/240	220/230/240
Nominal Output Frequency (Hz)	50/60	50/60	50/60	50/60
Output THDv (@Linear Load)	<3%	<3%	<3%	<3%
Switching from Grid Connected Mode to Standalone Mode	<10ms	<10ms	<10ms	<10ms
Switching from standalone mode to Grid connected mode	<10ms	<10ms	<10ms	<10ms
<b>AC Data (Generator)</b>				
Nominal Apparent Power from AC generator (kVA)	3.0	3.6	5.0	6.0
Max. Apparent Power from AC generator (VA)	3.3	3.96	5.5	6.6

Nominal Input Voltage (V)	220/230/240	220/230/240	220/230/240	220/230/240
Input Voltage Range (V)	170~280	170~280	170~280	170~280
Nominal AC generator Frequency (Hz)	50/60	50/60	50/60	50/60
AC generator Frequency Range (Hz)	45~55 / 55~65	45~55 / 55~65	45~55 / 55~65	45~55 / 55~65
Max. AC Current From AC generator (A)	32.0	32.0	40.0	40.0
Nominal AC Current From AC generator (A)	13.7 at 220V 13.1 at 230V 12.5 at 240V	16.4 at 220V 15.7 at 230V 15.0 at 240V	22.8 at 220V 21.8 at 230V 20.9 at 240V	27.3 at 220V 26.1 at 230V 25.0 at 240V
<b>Efficiency</b>				
Max. Efficiency	97.6%	97.6%	97.6%	97.6%
European Efficiency	96.2%	96.2%	96.2%	96.2%
CEC Efficiency	96.2%	96.2%	96.2%	96.2%
Max. Battery to AC Efficiency	95.5%	95.5%	95.5%	95.5%
MPPT Efficiency	99.9%	99.9%	99.9%	99.9%
<b>Protection</b>				
PV String Current Monitoring	Integrated	Integrated	Integrated	Integrated
PV Insulation Resistance Detection	Integrated	Integrated	Integrated	Integrated

Residual Current Monitoring	Integrated	Integrated	Integrated	Integrated
PV Reverse Polarity Protection	Integrated	Integrated	Integrated	Integrated
Anti-islanding Protection	Integrated	Integrated	Integrated	Integrated
AC Overcurrent Protection	Integrated	Integrated	Integrated	Integrated
AC Short Circuit Protection	Integrated	Integrated	Integrated	Integrated
AC Overvoltage Protection	Integrated	Integrated	Integrated	Integrated
DC Switch	Integrated	Integrated	Integrated	Integrated
DC Surge Protection	Type III	Type III	Type III	Type III
AC Surge Protection	Type III	Type III	Type III	Type III
AFCI	Optional	Optional	Optional	Optional
Rapid Shutdown	Optional	Optional	Optional	Optional
Remote Shutdown	Integrated	Integrated	Integrated	Integrated
<b>General Data</b>				
Operating Temperature Range (°C)	-35~+60	-35~+60	-35~+60	-35~+60
Operating Environment	Outdoor	Outdoor	Outdoor	Outdoor
Storage Temperature (°C)	-40~+85	-40~+85	-40~+85	-40~+85
Relative Humidity	0~95%	0~95%	0~95%	0~95%

Max. Operating Altitude (m)	3000	3000	3000	3000
Cooling Method	Natural Convection	Natural Convection	Natural Convection	Natural Convection
User Interface	LCD, WLAN+APP	LCD, WLAN+APP	LCD, WLAN+APP	LCD, WLAN+APP
Communication with BMS	CAN	CAN	CAN	CAN
Communication	RS485, WiFi+LAN+Bluetooth	RS485, WiFi+LAN+Bluetooth	RS485, WiFi+LAN+Bluetooth	RS485, WiFi+LAN+Bluetooth
Communication Protocols	Modbus-RTU、Modbus-TCP	Modbus-RTU、Modbus-TCP	Modbus-RTU、Modbus-TCP	Modbus-RTU、Modbus-TCP
Weight (kg)	14.5	15.5	15.5	15.5
Dimension (W×H×D mm)	560*415*204	560*415*204	560*415*204	560*415*204
Noise Emission (dB)	<30	<30	<30	<30
Topology	Non-isolated	Non-isolated	Non-isolated	Non-isolated
Self-consumption at Night (W)	<10	<10	<10	<10
Ingress Protection Rating	IP66	IP66	IP66	IP66
DC Connector	PV: jinko ((4~6 mm <sup>2</sup> ) BAT: OT (Max.35mm <sup>2</sup> )	PV: jinko ((4~6 mm <sup>2</sup> ) BAT: OT (Max.35mm <sup>2</sup> )	PV: jinko ((4~6 mm <sup>2</sup> ) BAT: OT (Max.35mm <sup>2</sup> )	PV: jinko ((4~6 mm <sup>2</sup> ) BAT: OT (Max.35mm <sup>2</sup> )
AC Connector	Tubulose (Max.10mm <sup>2</sup> )	Tubulose (Max.10mm <sup>2</sup> )	Tubulose (Max.10mm <sup>2</sup> )	Tubulose (Max.10mm <sup>2</sup> )



Environmental Category	4K4H	4K4H	4K4H	4K4H
Pollution Degree	III	III	III	III
Overvoltage Category	DC II / AC III	DC II / AC III	DC II / AC III	DC II / AC III
Protective Class	I	I	I	I
The Decisive Voltage Class (DVC)	Battery: A PV: C AC: C Com: A	Battery: A PV: C AC: C Com: A	Battery: A PV: C AC: C Com: A	Battery: A PV: C AC: C Com: A
Mounting Method	Wall Mounted	Wall Mounted	Wall Mounted	Wall Mounted
Active Anti-islanding Method	SMS(Slip-mode frequency) +AFD	SMS(Slip-mode frequency) +AFD	SMS(Slip-mode frequency) +AFD	SMS(Slip-mode frequency) +AFD
Type of Electrical Supply System	single phase	single phase	single phase	single phase
Country of Manufacture	China	China	China	China
Certification				
Grid Standards	NRS 097-2-1, IEC 62116, IEC 61727			
Safety Regulation	IEC 62109-1, IEC 62109-2			
EMC	IEC 62920, IEC 61000, EN 300328, EN 301489, EN IEC62311, EN 62479			

\*1: The Li-Ion battery usually contain two mainstream type: LFP and Ternary Lithium battery.

\*2: When the PV input voltage is higher than 500V, the battery charging and discharging power will be gradually limited, and the power limitation will be lifted after the input voltage is lowered.

\*4: When the input voltage is 580V-600V, the inverter will enter standby mode, and the voltage returns to 580V to enter the normal operation state.

\*5: Please refer to the user manual for the MPPT Voltage Range at Nominal Power.

\*6: The maximum input current per string is 16A. Or For the MPPT with two strings, the current of each string is 16A.

\*7: For Sri Lanka, Max. Output Power (kW) is 3.0kW for GW3000-ES-C10, 3.6kW for GW3600-ES-C10, 5.0kW for GW5000-ES-C10, 6.0kW for GW6000-ES-C10.

\*9: For Jordan, Max. AC Current Output to Utility Grid is 15.7A for GW3600-ES-C10.

\*10: For Jordan, Max. AC Active Power and Max. Apparent Power Output to Utility Grid are both 3.6kW/kVA for GW3600-ES-C10.

## 12.2 Battery Technical Data

### 12.2.1 LX A5.0-10

Technical Parameters	LX A5.0-10	2* LX A5.0-10	n*LX A5.0-10
Usable Energy (kWh) *1	5	10	n×5
Battery Module	LX A5.0-10: 51.2V 5.0kWh		
Number of Modules	1	2	n
Cell Type	LFP (LiFePO4)		
Nominal Voltage (V)	51.2		
Operating Voltage Range (V)	47.5~57.6		
Nominal Charge/Discharge Current (A) *2	60	120	n×60*3
Nominal Charge/Discharge Power (kW) *2	3	6	n×3*3
Operating Temperature Range (°C)	Range (°C) Charge: 0 ~ +50; Discharge: -10 ~ +50		
Relative Humidity	0~95%		
Max. Operating Altitude (m)	3000		
Communication	CAN		
Weight (kg)	40	80	n×40
Dimension (W×H×D mm)	LX A5.0-10 Module: 442×133×420 (Excluding hanger); 483×133×452 ( Including hanger)		

Technical Parameters		LX A5.0-10	2* LX A5.0-10	n*LX A5.0-10
Ingress Protection Rating		IP21		
Storage Temperature (°C)		0 ~ +40 (≤ One year); -20 ~ 0 (≤ One month); -40 ~ 45 (≤ One month)		
Mounting Method		Cabinet/Floor stacked		
Round-trip Efficiency *4		96.7%		
Cycle Life *5		≥5000		
Standard and Certification	Safety	IEC62619, IEC 63056, IEC62040-1, INmetro		
	EMC	EN IEC61000-6-1, EN IEC61000-6-2, EN IEC61000-6-3, EN IEC61000-6-4		
	Transportation	UN38.3, ADR		
<p>*1: Test conditions, 100% DOD, 0.2C charge &amp; discharge at +25±2°C for battery system at beginning life. System Usable Energy may vary with different Inverter.</p> <p>*2: Nominal Dis-/Charge Current and power derating will occur related to Temperature and SOC.</p> <p>*3: Based on Using Battery Combiner Box to parallelize battery modules.</p> <p>*4: Based on 2.5~3.65V voltage rang @25±2°C of Cell under C.2C/0.2C Cell test condition. Round-trip Efficiency is approximately 94%~95.</p> <p>*5: Based on 2.87~3.59V voltage rang @25±2°C of Cell under 0.6C/0.6C test condition and 70% EOL.</p> <p>n: Max. 15.</p>				

### 12.2.2 LX A5.0-30

Technical Parameters	LX A5.0-30
Nominal Capacity (kWh)	5.12
Usable energy (kWh) * 1	5
Cell Type	LFP (LiFePO4)

Technical Parameters	LX A5.0-30
Operating Voltage Range (V)	43.2~58.24
Nominal Charge Current (A) *2	60
Max. Continuous Charge Current (A) *2*3	90
Nominal Discharge Current (A) *2	100
Max. Continuous Discharge Current (A) *2*3	150
Max. Pulse Discharge Current (A) *2*3	<200A (30s)
Max. Continuous Discharge Power (W)	7200
Communication	CAN
Operating Temperature Range (°C)	Charge: $0 < T \leq 55$ Discharge: $-20 < T \leq 55$
Maximum Operating Altitude (m)	4000
Weight (Kg)	44
Dimensions (W x H x D mm)	442*133*520 (Excluding hanger) 483*133*559 (Including hanger)
Ingress Protection Rating	IP20
Application Method	On-grid/On-grid + Backup/ off Grid
Scalability	Max. 30 in Parallel (150kWh) (Hand to hand /Combiner box /Busbar)

Technical Parameters	LX A5.0-30
Mounting Method	19-inch standard rack, Floor-mounted, Wall-Mounted
Round-trip Efficiency*1	≥96%
Safety	IEC62619、IEC63056、N140
EMC	EN IEC61000-6-1、EN IEC61000-6-2、EN IEC61000-6-3、EN IEC61000-6-4
Transportation	UN38.3、ADR
Environment	ROHS

\*1 Test conditions: 100% DOD, 0.2C charge & discharge at 25°C± 2°C, at the beginning of life.

\*2 The system's working current and power values will be related to temperature and State of Charge (SOC)

\*3 Max charge / discharge current and power values maybe variant with different inverter models.

### 12.2.3 LX U5.0-30

Technical Parameters	LX U5.0-30
Nominal Battery Energy (kWh)	5.12
Usable Energy (kWh) *1	5
Cell Type	LiFePO4
Nominal Voltage (V)	51.2
Operating Voltage Range (V)	43.2~58.24
Nominal Charge Current (A)	60
Max. Continuous Charge Current (A)*2*3	90
Nominal Discharge Current (A)	100

Technical Parameters	LX U5.0-30
Max. Continuous Discharging Current (A) <sup>*2*3</sup>	100
Pulse Discharge Current (A) <sup>*2*3</sup>	< 200A (30S)
Max. Continuous Charge/Discharge Power (kW)	4.95
Communication	CAN
Charging Temperature Range (°C)	0<T≤55
Discharging Temperature Range (°C)	-20<T≤55
Ambient Temperature (°C)	0 < T ≤ 40 (Recommended 10 < T ≤ 30) Optional heating: -20 < T ≤ 40 (Recommend 10 < T ≤ 30)
Relative Humidity	5~95%
Max. Storage Time	12 Months (maintenance-free)
Max. Operating Altitude (m)	4000
Heating	Optional
Fire Suppression	Optional, Aerosol
Unit Weight (kg)	50
Unit Dimension (W×H×D mm)	460*580*160
Enclosure Protection Rating	IP65
Application	On Grid / On Grid + Backup / Off Grid
Scalability	30P
Mounting Method	Wall-/ Grounded- Mounted / Grounded
Round-trip Efficiency	≥96%
Cycle Life	> 6000 @25±2°C 0.5C 70%SOH 90%DOD
Safety	VDE2510-50, IEC62619, IEC62040, N140, IEC63056
EMC	EN IEC61000-6-1, EN IEC61000-6-2, EN IEC61000-6-3, EN IEC61000-6-4
Transportation	UN38.3, ADR
Environment	ROHS
Life (Year)	≥25

Technical Parameters	LX U5.0-30
<p>*1 Test conditions: 100% DOD, 0.2C charge &amp; discharge at 25°C±2°C, at the beginning of life.</p> <p>*2 The system's working current and power values will be related to temperature and State of Charge (SOC).</p> <p>*3 Max charge / discharge current values may be variant with different inverter models.</p>	

#### 12.2.4 GW14.3-BAT-LV-G10

Technical Data	GW14.3-BAT-LV-G10
Rated Energy (kWh)	14.3
Usable Energy (kWh)*1	≥13.8
Battery Type	LFP (LiFePO <sub>4</sub> )
Nominal Voltage (V)	51.2
Max. Continuous Charging Current (A)	224
Max. Continuous Discharging Current (A)	260
Max. Input Power (System) (kW)*2	12
Max. Output Power (System) (kW)*2	12 (13.2 @10min)
Peak Output Power (System) (kW)*2	20 @15s
Charging Temperature Range (°C)	0~55
Discharging Temperature Range (°C)	-20~55
Relative Humidity	5~85%
Max. Operating Altitude (m)	4000
Noise Emission (dB)	≤35

<b>Technical Data</b>		<b>GW14.3-BAT-LV-G10</b>
Communication		CAN, RS485
Weight (kg)		125
Dimensions (W×H×D mm)		530*885*246 (Without the base) 530*918.6*246 (With base included)
Optional Function Configuration		Aerosol
Ingress Protection		IP20
Storage Temperature (°C)		-20~45
Ambient Temperature (°C)		0~45 (Standard configuration) 10~35 (Recommend ) -20~45 (Optional)
Max. Storage time		12 months (-20°C~35°C) 6 months (35°C~45°C)
Scalability		16 pcs
Mounting Method		Floor-Mounted, Wall-Mounted
Cycle Life		≥6500 (25±2°C, 0.5C, 90%DOD, 70%EOL)
Country of Manufacture		China
Standard and Certification	Safety	IEC 62619, IEC 63056, IEC 60730-1
	EMC	EN IEC61000-6-1, EN IEC61000-6-2, EN IEC61000-6-3, EN IEC61000-6-4
	Transportation	UN38.3, ADR, MSDS

\*1: Test conditions, 100% DOD (cell 2.85~3.6V voltage range), 0.2P charge & discharge at 25±2 °C for battery system at the beginning of life. Usable energy is



defined by its initial design value. Actual available energy may vary depending on charge/discharge rate, environmental conditions (e.g. temperature), transport and storage factors.

\*2: Max. Input Power /Max. Output Power/Peak.Output Power derating will occur related to Temperature and SOC.

## 12.3 Smart Meter Technical Data

### 12.3.1 GMK110

Technical Parameters		GMK110	
	Application	Single phase	
Input Data	Voltage	Nominal Voltage (V)	220
		Voltage Range (V)	85~288
		Nominal Voltage Frequency (Hz)	50/60
	Current	CT Ratio	120A/40mA
		CT Quantity	1
Communication		RS485	
Communication Distance (m)		1000	
User Interface		2LED	
Accuracy	Voltage/Current		Class I
	Active Energy		Class I
	Reactive Energy		Class II
Power Consumption (w)		<5	
Mechanical Parameters	Dimension (W×H×D mm)		19*85*67
	Weight (g)		50
	Mounting Method		Rail Installation
Environmental Parameters	Ingress Protection Rating		IP20
	Operating Temperature Range (°C)		-30~ 60
	Storage Temperature Range (°C)		-30~ 60
	Relative Humidity (Non-Condensing)		0~95%
Max. Operating Altitude (m)		3000	

### 12.3.2 GM330

Technical Parameters		GM330
Measuring Range	Support Grid Type	Three-phase, split-phase, single-phase
	Voltage Range L-L (Vac)	172~817
	Voltage Range L-N (Vac)	100~472
	Nominal Frequency (Hz)	50/60
	CT Ratio	nA:5A
Communication Parameters	Communication Method	RS485
	Communication Distance (m/ft)	1000/3280
Precision Accuracy	Voltage/Current	Class 0.5
	Active Energy	Class 0.5
	Reactive Energy	Class 1
General Data	Dimension (WxHxDmm/in)	72x85x72/2.83x3.35x2.83
	Housing	4 modules
	Weight (g/lb)	240/0.53
	Mounting Method	DIN rail
	User Interface	4 LEDs, Reset Button
	Power Consumption (w)	<5
Environmental Parameters	Ingress Protection Rating	IP20
	Operating Temperature Range (°C/°F)	-30~+70/-22~+158
	Storage Temperature Range (°C/°F)	-30~70/-22~+158
	Relative Humidity (No Condensing)	0~95%
	Max. Operating Altitude (m/ft)	3000/9842
Certification Parameters	Certificate	UL1741/ANSI

### 12.4 Smart Dongle Technical Data

### 12.4.1 WiFi/LAN Kit-20

Technical Parameters		WiFi/LAN Kit-20
Output Voltage (V)		5
Power Consumption (W)		<2
Communication Interface		USB
Communication Parameters	Ethernet	10M/100Mbps Self-adaption
	Wireless	IEEE 802.11 b/g/n @2.4 GHz
	Bluetooth	Bluetooth V4.2 BR/EDR and Bluetooth LE standard
Mechanical Parameters	Dimension (W×H×D mm)	48.3*159.5*32.1
	Weight (g)	82
	Ingress Protection Rating	IP65
	Mounting Method	USB port insertion and removal
Operating Temperature Range (°C)		-30~+60
Storage Temperature Range (°C)		-40~+70
Relative Humidity		0-95%
Max. Working Altitude (m)		4000

### 12.4.2 4G Kit-CN-G20, 4G Kit-CN-G21

Technical Parameters		WiFi/LAN Kit-20
Output Voltage (V)		5
Power Consumption (W)		<2
Communication Interface		USB
Communication Parameters	Ethernet	10M/100Mbps Self-adaption
	Wireless	IEEE 802.11 b/g/n @2.4 GHz
	Bluetooth	Bluetooth V4.2 BR/EDR and Bluetooth LE standard
Mechanical Parameters	Dimension (W×H×D mm)	48.3*159.5*32.1
	Weight (g)	82
	Ingress Protection Rating	IP65
	Mounting Method	USB port insertion and removal

Technical Parameters	WiFi/LAN Kit-20
Operating Temperature Range (°C)	-30~+60
Storage Temperature Range (°C)	-40~+70
Relative Humidity	0-95%
Max. Working Altitude (m)	4000

### 12.4.3 Ezlink3000

Technical Parameters	Ezlink3000
General Data	
Connection Interface	USB
Ethernet Interface (optional)	10/100Mbps self-adaption, communication distance ≤100m
Mounting Method	Plug-and-play
Indicator	LED indicator
Dimension (W×H×D mm)	49*153*32
Weight (g)	130
Ingress Protection Rating	IP65
Power Consumption (W)	≤2W (typical value)
Working Mode	STA
Wireless Parameters	
Bluetooth Communication	Bluetooth 5.1
WiFi Communication	802.11 b/g/n (2.412GHz-2.484GHz)
Environmental Parameters	
Operating Temperature Range (°C)	-30~ +60
Storage Temperature Range (°C)	-30~ +70
Relative Humidity	0-100% (no condensing)
Max. Working Altitude (m)	4000

## 13 Appendix

### 13.1 FAQ

#### 13.1.1 How to conduct auxiliary detection for smart meters/CT?

Meter detection function, which can detect whether the CT of the meter is connected correctly and the current operation status of the meter and CT.

- Approach 1:

1. Access the detection page through **Home > Settings > Electricity Meter/ CT Auxiliary Detection**.
2. Click "Start Detection" and wait for the detection to complete. Then, view the detection results.

- Approach 2:

1. Access the detection  page through **> [System Setup] > [Quick Setting] > [Meter/CT Assisted Test]**.
2. Click "Start Detection" and wait for the detection to complete. Then, view the detection results.

#### 13.1.2 How to Upgrade the Device Version

Through the firmware information, you can view or upgrade the DSP version, ARM version, BMS version, and smart dongle software version of the inverter. Some smart dongles do not support software version upgrade via SolarGo App, and the actual situation shall prevail.

- **Upgrade prompt:**

When the user opens the APP, an upgrade prompt will pop up on the homepage, and the user can choose whether to upgrade or not. If you choose to upgrade, you can complete the upgrade by following the prompts on the interface.

- **Regular upgrade:**

**Access the firmware information viewing interface through "Home" > "Settings" > "Firmware Information"**

Click "Check for Updates". If there is a new version, complete the upgrade according to the prompts on the interface.

- **Forced Upgrade:**

The APP will push upgrade information, and users need to upgrade according to the prompts to continue using the app. You can complete the upgrade by following the prompts on the interface.

## 13.2 Abbreviations

Abbreviation	English Description	Chinese Description
Ubatt	Battery Voltage Range	电池电压范围
Ubatt,r	Nominal Battery Voltage	额定电池电压
Ibatt,max (C/D)	Max. Charging Current Max. Discharging Current	最大充/放电电流
EC,R	Rated Energy	额定能量
UDCmax	Max.Input Voltage	最大输入电压
UMPP	MPPT Operating Voltage Range	MPPT 电压范围
IDC,max	Max. Input Current per MPPT	每路 MPPT 最大输入电流
ISC PV	Max. Short Circuit Current per MPPT	每路 MPPT 最大短路电流
PAC,r	Nominal Output Power	Nominal Output Power
Sr (to grid)	Nominal Apparent Power Output to Utility Grid	额定并网输出视在功率
Smax (to grid)	Max. Apparent Power Output to Utility Grid	最大并网输出视在功率
Sr (from grid)	Nominal Apparent Power from Utility Grid	从电网买电额定输出视在功率
Smax (from grid)	Max. Apparent Power from Utility Grid	从电网买电最大输出视在功率
UAC,r	Nominal Output Voltage	Nominal Output Voltage
fAC,r	Nominal AC Grid Frequency	输出电压频率
IAC,max(to grid)	Max. AC Current Output to Utility Grid	最大并网输出电流
IAC,max(from grid)	Max. AC Current From Utility Grid	最大输入电流
P.F.	Power Factor	功率因数

Abbreviation	English Description	Chinese Description
Sr	Back-up Nominal apparent power	离网额定视在功率
Smax	Max. Output Apparent Power (VA) Max. Output Apparent Power without Grid	最大输出视在功率
IAC,max	Max. Output Current	最大输出电流
UAC,r	Nominal Output Voltage	最大输出电压
fAC,r	Nominal Output Frequency	额定输出电压频率
Toperating	Operating Temperature Range	工作温度范围
IDC,max	Max. Input Current	最大输入电流
UDC	Input Voltage	输入电压
UDC,r	DC Power Supply	直流输入
UAC	Power Supply/AC Power Supply	输入电压范围/交流输入
UAC,r	Power Supply/Input Voltage Range	输入电压范围/交流输入
Toperating	Operating Temperature Range	工作温度范围
Pmax	Max Output Power	最大功率
PRF	TX Power	发射功率
PD	Power Consumption	功耗
PAC,r	Power Consumption	功耗
F (Hz)	Frequency	频率
ISC PV	Max. Input Short Circuit Current	最大输入短路电流
Udcmin-Udcmax	Range of input Operating Voltage	工作电压范围
UAC,rang(L-N)	Power Supply Input Voltage	适配器输入电压范围
U <sub>sys,max</sub>	Max System Voltage	最大系统电压
Haltitude,max	Max. Operating Altitude	最高工作海拔高度
PF	Power Factor	功率因数
THDi	Total Harmonic Distortion of Current	电流谐波
THDv	Total Harmonic Distortion of Voltage	电压谐波

Abbreviation	English Description	Chinese Description
C&I	Commercial & Industrial	工商业
SEMS	Smart Energy Management System	智慧能源管理系统
MPPT	Maximum Power Point Tracking	最大功率点跟踪
PID	Potential-Induced Degradation	电位诱发衰减
Voc	Open-Circuit Voltage	开路电压
Anti PID	Anti-PID	防PID
PID Recovery	PID Recovery	PID修复
PLC	Power-line Commucation	电力线载波通信
Modbus TCP/IP	Modbus Transmission Control / Internet Protocol	基于TCP/IP层的modbus
Modbus RTU	Modbus Remote Terminal Unit	基于串行链路的modbus
SCR	Short-Circuit Ratio	短路比
UPS	Uninterruptable Power Supply	不间断电源
ECO mode	Economical Mode	经济模式
TOU	Time of Use	使用时间
ESS	Energy Stroage System	储能系统
PCS	Power Conversion System	电能转换系统
RSD	Rapid shutdown	Rapid Shutdown
EPO	Emergency Power Off	紧急关断
SPD	Surge Protection Device	防雷保护
ARC	zero injection/zero export Power Limit / Export Power Limit	防逆流
DRED	Demand Response Enabling Device	命令响应设备
RCR	Ripple Control Receiver	-
AFCI	AFCI	AFCI直流拉弧保护
GFCI	Ground Fault Circuit Interrupter	接地故障分断器
RCMU	Residual Current Monitoring Unit	残余电流监控装置
FRT	Fault Ride Through	故障穿越
HVRT	High Voltage Ride Through	高电压穿越



Abbreviation	English Description	Chinese Description
LVRT	Low Voltage Ride Through	低电压穿越
EMS	Energy Management System	能量管理系统
BMS	Battery Management System	电池管理系统
BMU	Battery Measure Unit	电池采集单元
BCU	Battery Control Unit	电池控制单元
SOC	State of Charge	电池的荷电状态
SOH	State of Health	电池健康度
SOE	State Of Energy	电池剩余能量
SOP	State Of Power	电池充放电能力
SOF	State Of Function	电池的功能状态
SOS	State Of Safety	安全状态
DOD	Depth of discharge	放电深度

### 13.3 Explanation of Terms

- **Overvoltage Category Definition**

- **Category I:** applies to equipment connected to a circuit where measures have been taken to reduce transient overvoltage to a low level.
- **Category II:** applies to fixed downstream equipment. For example, appliances, portable tools and other plug-connected equipment; Voltage category III is used if there are special requirements for the reliability and suitability of such equipment.
- **Category III:** applies to fixed downstream equipment, including the main distribution board. For example, switchgear and other equipment in an industrial installation
- **Category IV:** applies to the upstream equipment in the power supply of the distribution device, including measuring instruments and upstream over-current protection devices.

- **Definition of Types of Damp Places**

Environmental Parameters	Level		
	3K3	4K2	4K4H
Temperature Range	0~+40°C	-33~+40°C	-33~+40°C
Humidity Range	5% to 85%	5% to 85%	5% to 85%

- **Definition of Environmental Category:**

- **Outdoor Inverter:** The ambient air temperature range is -25 to +60°C, and it is suitable for environments with pollution degree 3.
- **Indoor Type II Inverter:** The ambient air temperature range is -25 to +40°C, and it is suitable for environments with pollution degree 3.
- **Indoor Type I Inverter:** The ambient air temperature range is 0 to +40°C, and it is suitable for environments with pollution degree 2.
- **Definition of Pollution Degree Categories:**
  - **Pollution Degree 1:** No pollution or only dry non-conductive pollution.
  - **Pollution Degree 2:** In general, there is only non-conductive pollution, but the transient conductive pollution caused by occasional condensation must be taken into account.
  - **Pollution Degree 3:** There is conductive pollution, or the non-conductive pollution becomes conductive pollution due to condensation.
  - **Pollution Degree 4:** Persistent conductive pollution, such as pollution caused by conductive dust or rain and snow.

### 13.4 Battery SN Code Meaning

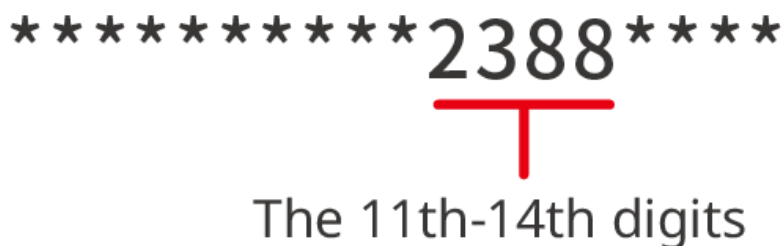

LXD10DSC0002

Bits 11-14 of the product SN code are the production time code.

The above picture has a production date of 2023-08-08

- The 11th and 12th digits are the last two digits of the year of production, e.g., 2023 is represented by 23;
- The 13th digit is the month of production, e.g., August is represented by 8; as follows:

Month	1~ 9	10	11	12
Month	1~ 9	A	B	C

- The 14th digit is the date of production, e.g., the 8th day is indicated by 8;

priority is given to the use of numerical representation, e.g., 1~9 indicates the 1st~9th day, A indicates the 10th day, and so on. The letters I and O are not used to avoid confusion. The details are as follows:

Production Date	1	2	3	4	5	6	7	8	9
Code	1	2	3	4	5	6	7	8	9

Production Date	10	11	12	13	14	15	16	17	18	19	20
Code	A	B	C	D	E	F	G	H	J	K	L

Production Date	21	22	23	24	25	26	27	28	29	30	31
Code	M	N	P	Q	R	S	T	U	V	W	X

## 14 Contact Details

GoodWe Technologies Co., Ltd.  
No. 90 Zijin Rd., New District, Suzhou, China  
400-998-1212  
[www.goodwe.com](http://www.goodwe.com)  
[service@goodwe.com](mailto:service@goodwe.com)