

V2.1 2026-05-29

Residential Smart Inverter

ET G2 6.0-15.0kW

- Lynx Home F G2
- Lynx Home F
- Lynx Home F Plus+
- Lynx Home D

Solutions Manual

GOODWE

Copyright Statement

Copyright Statement

Copyright© GoodWe Technologies Co., Ltd. 2026. All rights reserved.

Without the authorization of GoodWe Technologies Co., Ltd., no part of this manual may be reproduced, disseminated, or uploaded to public networks or other third-party platforms in any form.

Trademark Authorization

GOODWE and other GOODWE trademarks used in this manual are owned by GoodWe Technologies Co., Ltd. All other trademarks or registered trademarks mentioned in this manual belong to their respective owners.

NOTICE

Due to product version upgrades or other reasons, the document content will be updated periodically. Unless otherwise agreed, the document content cannot replace the safety precautions on the product label. All descriptions in the document are for guidance only.

About This Manual

Overview

This document primarily introduces the product information, installation and wiring, configuration and commissioning, troubleshooting, and maintenance content for the energy storage system composed of inverters, battery systems, and smart meters. Please read this manual carefully before installing and using the product to understand the product safety information and familiarize yourself with the product's functions and features. The document may be updated periodically; please obtain the latest version and more product information from the official website.

Applicable Model

The energy storage system includes the following products:

Product Type	Product Information	Description
Inverter	ET G2 6-15kW	Nominal output power from 6kW to 15kW.
Battery system	Lynx Home F G2	Single cluster storage capacity from 9.6kWh to 28.8kWh. Maximum parallel cluster storage capacity up to 230.4kWh
	Lynx Home F, Lynx Home F Plus+	Single cluster storage capacity from 6.6kWh to 16.38kWh. Maximum parallel cluster storage capacity up to 131.04kWh.
	Lynx Home D	Single cluster storage capacity 5kWh. Maximum parallel cluster storage capacity up to 40kWh.
Meter	GM3000	Monitoring module in the energy storage system, capable of detecting operating voltage, current, and other information within the system.
	GM330	

Product Type	Product Information	Description
Smart Dongle	WiFi/LAN Kit-20	Uploads system operating information to the monitoring platform via WiFi or LAN signal.
	LS4G Kit-CN, 4G Kit-CN, 4G Kit-CN-G20 or 4G Kit-CN-G21 (China only)	Uploads system operating information to the monitoring platform via 4G signal.
	Ezlink3000	Connected to the master inverter in parallel system scenarios. Uploads system operating information to the monitoring platform via WiFi or LAN signal.

Symbol Definition



 DANGER
Indicates a situation with a high potential hazard, which, if not avoided, will result in death or serious injury.
 WARNING
Indicates a situation with a moderate potential hazard, which, if not avoided, could result in death or serious injury.
 CAUTION
Indicates a situation with a low potential hazard, which, if not avoided, could result in moderate or minor injury.
NOTICE
Emphasizes or supplements the content, may provide tips or tricks for optimal product use, and can help you solve a problem or save you time.

Table of Contents

1 Safety Precautions	10
1.1 General Safety	10
1.2 personnel requirements	11
1.3 System Safety	12
1.3.1 PV String Safety	14
1.3.2 Inverter Safety	14
1.3.3 Battery Safety	15
1.3.4 Smart Meter Safety	17
1.4 Safety Symbols and Certification Marks	17
1.5 EU Declaration of Conformity	19
1.5.1 Equipment with Wireless Communication Modules	19
1.5.2 Equipment without Wireless Communication Modules (Except Battery)	20
1.5.3 Battery	20
2 System Introduction	22
2.1 System Overview	22
2.2 Product Overview	26
2.2.1 Inverter	26
2.2.2 Battery	28
2.2.2.1 Lynx Home F, Lynx Home F Plus+	28
2.2.2.2 Lynx Home F G2	29
2.2.2.3 Lynx Home D	30

2.2.3 Smart Meter	34
2.2.4 Smart Dongle	35
2.3 Supported Grid Types	36
2.4 System Working Mode	36
2.5 Features	46
3 Check and Storage	50
3.1 Check Before Receiving	50
3.2 deliverables	50
3.2.1 Inverter Deliverables	50
3.2.2 Batteries Deliverables	53
3.2.2.1 Batteries Deliverables (Lynx Home D)	53
3.2.2.2 Lynx Home F 、Lynx Home F Plus+	56
3.2.2.3 Lynx Home F G2	58
3.3 Smart Meter Deliverables (GM3000)	59
3.4 Smart Meter (GM330)	59
3.5 Smart dongle deliverables	60
3.6 Storage	61
4 Installation	64
4.1 System Installation and Commissioning Procedure	64
4.2 Installation Requirements	64
4.2.1 Installation Environment Requirements	64
4.2.2 Installation Space Requirements	67

4.2.3 Tool Requirements.....	68
4.3 Equipment Handling.....	70
4.4 Installing the Inverter.....	71
4.5 Installing the Battery System.....	72
4.5.1 Installing Lynx Home F Series.....	72
4.5.1.1 Installing Lynx Home F.....	73
4.5.1.2 Installing Lynx Home F Plus+.....	74
4.5.1.3 Installing Lynx Home F G2.....	76
4.5.2 Installing Lynx Home D.....	79
4.6 Installing the Smart Meter.....	83
5 System Wirings.....	85
5.1 System Wiring Electrical Block Diagram.....	85
5.2 Detailed System Wiring Diagram.....	88
5.2.1 Detailed System Wiring Diagram for Single Inverter.....	89
5.2.2 Detailed System Wiring Diagram for Parallel System.....	94
5.3 Preparing Materials.....	97
5.3.1 Preparing Breakers.....	97
5.3.2 Preparing Cables.....	99
5.4 Connecting the PE cable.....	102
5.4.1 Inverter Grounding.....	103
5.4.2 Battery System Grounding.....	103
5.5 Connecting the PV Cable.....	104

5.6 Connecting the AC Cable.....	106
5.7 Connecting the Battery Cable.....	108
5.7.1 Connecting the Power Cable between the Inverter and Battery.....	112
5.7.2 Connecting the Communication Cable between the Inverter and Battery.....	117
5.7.3 Connecting Power Cables between Lynx Home D Batteries.....	119
5.7.4 Connecting Battery Communication Cables and Terminal Resistors.....	121
5.7.5 Installing the Battery Protective Cover.....	123
5.8 Connecting the Meter Cable.....	123
5.9 Connecting the Inverter Communication Cable.....	127
5.10 Connecting the Smart Dongle.....	130
6 System Commissioning.....	133
6.1 Check Before Power ON.....	133
6.2 Power ON.....	133
6.3 Indicators.....	134
6.3.1 Inverter Indicators.....	134
6.3.2 Battery Indicators.....	135
6.3.2.1 Lynx Home F Series.....	135
6.3.2.2 Lynx Home D.....	137
6.3.3 Smart Meter Indicator.....	139
6.3.4 Smart Dongle Indicator.....	140
7 System Commissioning and Power Plant Monitoring.....	144

7.1 Device Commissioning and Power Plant Monitoring via SEMS+ App	144
7.2 Device Commissioning and Power Plant Monitoring via SEMS+ WEB	145
8 Maintenance	147
8.1 Power OFF the System	147
8.2 Removing the Equipment	148
8.3 Disposing of the Equipment	149
8.4 Routine Maintenance	149
8.5 fault	150
8.5.1 Viewing Fault/Alarms Information	150
8.5.2 Fault Information and Troubleshooting	151
8.5.2.1 System Fault	151
8.5.2.2 Inverter Fault	153
8.5.2.2.1 Troubleshooting (Fault Codes F01-F40)	153
8.5.2.2.2 Troubleshooting (Fault Codes F41-F80)	171
8.5.2.2.3 Troubleshooting (Fault Codes F81-F121)	180
8.5.2.2.4 Troubleshooting (Fault Codes F122-F163)	192
8.5.2.2.5 Troubleshooting for Fault Phenomena	200
9 technical parameter	219
9.1 Inverter Parameters	219
9.2 Battery Parameters	227
9.2.1 Lynx home F	227
9.2.2 Lynx home F Plus+	228

9.2.3 Lynx home F G2	230
9.2.4 Lynx home D	232
9.3 Smart Meter Technical Data	232
9.3.1 GM330	232
9.3.2 GM3000	233
9.4 Smart Dongle Technical Data	234
9.4.1 WiFi/LAN Kit-20	234
9.4.2 4G Kit-CN-G20	235
9.4.3 4G Kit-CN-G21	236
9.4.4 Ezlink3000	237
9.4.5 LS4G Kit-CN	238
9.4.6 4G Kit-CN	239
10 Appendix	241
10.1 FAQ	241
10.1.1 How to Upgrade the Device Version	241
10.2 Explanation of Terms	241
10.3 Battery SN Code Definition	242
10.4 Safety Regulation Countries	243
10.5 Australia Safety Regulations	249
11 Contact Details	254

1 Safety Precautions

Please always adhere to the safety precaution information contained in this document when operating the equipment.

WARNING

The equipment has been strictly designed and tested in compliance with safety regulations. However, as electrical equipment, relevant safety instructions must be followed before performing any operations. Improper handling may lead to serious injury or property damage.

1.1 General Safety

NOTICE

- Due to product version upgrades or other reasons, the document content is updated periodically. Unless otherwise specified, the document content cannot replace the safety precautions on the product label. All descriptions in the document are for guidance only.
- Please read this document carefully before installing the equipment to understand the product and precautions.
- All operations on the equipment must be performed by professional and qualified electrical technicians who are familiar with the relevant standards and safety regulations in the project location.
- When operating the equipment, use insulated tools and wear personal protective equipment to ensure personal safety. Wear anti-static gloves, anti-static wrist straps, anti-static clothing, etc., when handling electronic components to protect the equipment from electrostatic damage.
- Unauthorized disassembly or modification may cause equipment damage, and such damage is not covered by the warranty.
- Equipment damage or personal injury caused by failure to install, use, or configure the equipment in accordance with the requirements of this document or the corresponding user manual is beyond the manufacturer's liability. For more product warranty information, please obtain it through the official website: <https://en.goodwe.com/warrantyrelated.html>.

1.2 personnel requirements

NOTICE

To ensure the safety, compliance, and efficiency throughout the entire process of equipment transportation, installation, wiring, operation, and maintenance, it must be performed by professionals or qualified personnel.

1. Professionals or qualified personnel include:
 - Personnel who have mastered the working principles, system structure, knowledge of risks and hazards, and have received professional operation training or possess rich practical experience.
 - Personnel who have received relevant technical and safety training, have certain operational experience, can recognize the dangers that specific tasks may pose to themselves, and can take protective measures to minimize risks to themselves and others.
 - Qualified electrical technicians who meet the regulatory requirements of the country/region where they are located.
 - Personnel with an electrical engineering degree/advanced diploma in electrical discipline or equivalent/professional qualification in the electrical field, and with at least 2/3/4 years of experience in testing and supervision work using electrical equipment safety standards.
2. Personnel involved in special tasks such as electrical work, high-altitude work, and special equipment operation must hold valid qualification certificates required by the location of the equipment.
3. Medium-voltage equipment operation must be performed by certified high-voltage electricians.
4. Equipment and component replacement is only allowed to be performed by authorized personnel.

1.3 System Safety



- Before performing electrical connections, disconnect all upstream switches of the equipment to ensure the equipment is powered off. Live operation is strictly prohibited, otherwise hazards such as electric shock may occur.
- To prevent personal injury or equipment damage caused by live operation, a circuit breaker must be added to the voltage input side of the equipment.
- All operations such as transportation, storage, installation, operation, use, and maintenance must comply with applicable laws, regulations, standards, and specifications.
- The specifications of cables and components used for electrical connections must comply with local laws, regulations, standards, and specifications.
- Please use the cable connectors provided with the equipment to connect the equipment cables. If other models of connectors are used, any resulting equipment damage is not within the responsibility of the equipment manufacturer.
- Ensure all cable connections on the equipment are correct, secure, and not loose. Improper wiring may cause poor contact or damage the equipment.
- The equipment's protective ground wire must be securely connected.
- To protect the equipment and its components from damage during transportation, ensure transport personnel are professionally trained. Record the operation steps during transportation and keep the equipment balanced to avoid dropping.
- The equipment is heavy. Please assign personnel according to the equipment's weight to prevent it from exceeding the human handling capacity, which could cause injury from falling.
- Ensure the equipment is placed stably and not tilted. Equipment tipping over may cause equipment damage and personal injury.
- Do not wear metal objects during Equipment Handling, Installation, or testing to avoid equipment damage or electric shock injury.
- Do not place metal parts on the equipment to prevent electric shock injury from conductivity.



- During equipment Installation, avoid placing weight on the wiring terminals, otherwise it will cause terminal damage.
- If the cable bears excessive tension, it may cause poor connection. When wiring, leave a certain length of cable slack before connecting it to the equipment's wiring port.
- Cables of the same type should be bundled together. Different types of cables should be routed at least 30mm apart and must not be entangled or cross-routed.
- Using cables in high-temperature environments may cause insulation aging and damage. Maintain a distance of at least 30mm between cables and heating components or the periphery of heat source areas.

1.3.1 PV String Safety

DANGER

- Please use the DC terminal blocks supplied with the unit to connect the inverter DC cables. Using other models of DC terminal blocks may lead to serious consequences. Equipment damage caused thereby is not within the responsibility of the equipment manufacturer.

WARNING

- Ensure the component frame and bracket system are properly grounded.
- After connecting the DC cables, ensure the connections are tight and secure without any looseness.
- Use a multimeter to measure the positive and negative poles of the DC cables to ensure correct polarity without reverse connection, and that the voltage is within the allowable range.
- Do not connect the same PV string to multiple inverters, as this may cause inverter damage.

1.3.2 Inverter Safety

WARNING

- Ensure the voltage and frequency of the grid connection point comply with the inverter's grid-connection specifications.
- It is recommended to add protective devices such as circuit breakers or fuses on the AC side of the inverter. The rating of the protective device must be greater than 1.25 times the inverter's maximum AC output current.
- If the inverter triggers an arc fault alarm less than 5 times within 24 hours, the alarm can be cleared automatically. After the 5th arc fault alarm, the inverter will shut down for protection. The inverter can only resume normal operation after the fault is cleared.
- If the photovoltaic system is not configured with a battery, it is not recommended to use the BACK-UP function, as it may cause a system power outage risk.
- Changes in grid voltage and frequency may cause the inverter's output power to derate.

1.3.3 Battery Safety

DANGER

- This battery system is a high-voltage system, and high voltage is present during equipment operation. Before operating any equipment in the system, ensure the equipment is powered off to avoid the risk of electric shock. Strictly adhere to all safety precautions in this manual and the safety labels on the equipment during operation.
- Do not disassemble, modify, or repair the battery or control box without official authorization from the equipment manufacturer, otherwise it may cause electric shock or equipment damage. Losses incurred as a result are beyond the manufacturer's liability.
- Do not impact, pull, drag, squeeze, or step on the equipment, and do not place the battery in fire, otherwise there is a risk of battery explosion.
- Do not place the battery in high-temperature environments. Ensure there are no heat sources near the battery and that it is not exposed to direct sunlight. When the ambient temperature exceeds 60°C, a fire may occur.
- Do not use the battery if it or the control box has obvious defects, cracks, damage, or other abnormalities. Battery damage may cause electrolyte leakage.
- Do not move the battery system while it is operating.
- If battery replacement or addition is required, please contact the after-sales service center.
- Battery short circuit may cause personal injury. The instantaneous high current from a short circuit can release a large amount of energy, which may cause a fire.

WARNING

- If the battery is completely discharged, please charge the battery strictly according to the user manual for the corresponding model.
- Battery current may be affected by some factors, such as temperature, humidity, weather conditions, etc., which may cause current limiting and affect load capacity.
- If the battery cannot start, please contact the after-sales service center as soon as possible. Otherwise, the battery may be permanently damaged.

- Battery electrolyte leakage

If a battery module leaks electrolyte, avoid contact with the leaking liquid or gas. Electrolyte is corrosive, and contact may cause skin irritation and chemical burns. If accidental contact with the leaking substance occurs, take the following actions:

- inhalation: Evacuate from the contaminated area and seek medical help immediately.
- Eye contact: Flush with clean water for at least 15 minutes and seek medical help immediately.
- Skin contact: Wash the affected area thoroughly with soap and water and seek medical help immediately.
- Ingestion: Induce vomiting and seek medical assistance immediately.

- Fire

- When the battery temperature exceeds 150°C, there is a risk of fire. A battery fire may release toxic and harmful gases.
- To prevent fire, ensure that carbon dioxide, Novec1230, or FM-200 fire extinguishers are available near the equipment.
- When extinguishing a fire, do not use ABC dry powder fire extinguishers. Firefighters must wear protective clothing and self-contained breathing apparatus.

1.3.4 Smart Meter Safety













 **WARNING**











If the grid voltage fluctuation exceeds 265V, long-term overvoltage operation may damage the meter. It is recommended to add a fuse with a rated current of 0.5A on the voltage input side of the meter to protect it.

1.4 Safety Symbols and Certification Marks

 **DANGER**

- After the equipment is installed, the labels and warning signs on the enclosure must remain clearly visible. Do not cover, alter, or damage them.
- The following enclosure warning label descriptions are for reference only. Please refer to the actual labels used on the equipment.

No.	Symbol	Meaning
1		Potential hazard exists during equipment operation. Take precautions when operating the equipment.
2		High voltage hazard. High voltage is present during equipment operation. Ensure the equipment is powered off before performing any operations.
3		High temperature on inverter surface. Do not touch during operation to avoid burns.
4		Use the equipment properly. Operation under extreme conditions carries a risk of explosion.
5		Battery contains flammable materials. Risk of fire.
6		Equipment contains corrosive electrolyte. Avoid contact with leaked electrolyte or its vapors.
7		Delayed discharge. After powering off the equipment, wait for 5 minutes until it is fully discharged.
8		Keep the equipment away from open flames or ignition sources.
9		Keep the equipment out of reach of children.
10		Use the equipment properly. Operation under extreme conditions carries a risk of explosion.
11		Battery contains flammable materials. Risk of fire.
12		Do not lift the equipment after the battery system wiring is completed or while the battery system is operating.

No.	Symbol	Meaning
13		Do not extinguish with water.
14		Read the product manual carefully before operating the equipment.
15		Wear personal protective equipment during installation, operation, and maintenance.
16		Do not dispose of the equipment as household waste. Dispose of the equipment according to local laws and regulations, or return it to the manufacturer.
17		Do not directly disconnect or plug/unplug the DC terminals while the equipment is operating.
18		Grounding point.
19		Recycling symbol.
20		CE certification mark.
21		TUV mark.
22		RCM mark.

1.5 EU Declaration of Conformity

1.5.1 Equipment with Wireless Communication Modules

Equipment with Wireless Communication Modules sold in the European market must comply with the following directives:

- Radio Equipment Directive 2014/53/EU (RED)
- Restrictions of Hazardous Substances Directive 2011/65/EU and (EU) 2015/863

(RoHS)

- Waste Electrical and Electronic Equipment 2012/19/EU
- Registration, Evaluation, Authorization and Restriction of Chemicals (EC) No 1907/2006 (REACH)

1.5.2 Equipment without Wireless Communication Modules (Except Battery)

Equipment without wireless communication modules that can be sold on the European market must meet the requirements of the following directives:

- Electromagnetic compatibility Directive 2014/30/EU (EMC)
- Electrical Apparatus Low Voltage Directive 2014/35/EU (LVD)
- Restrictions of Hazardous Substances Directive 2011/65/EU and (EU) 2015/863 (RoHS)
- Waste Electrical and Electronic Equipment 2012/19/EU
- Registration, Evaluation, Authorization and Restriction of Chemicals (EC) No 1907/2006 (REACH)

1.5.3 Battery

Batteries that can be sold in the European market meet the following directive requirements:

- Electromagnetic compatibility Directive 2014/30/EU (EMC)
- Electrical Apparatus Low Voltage Directive 2014/35/EU (LVD)
- Restrictions of Hazardous Substances Directive 2011/65/EU and (EU) 2015/863 (RoHS)*¹
- Regulation (EU) 2023/1542 Article 12 - Safety of stationary battery energy storage systems
- Regulation (EU) 2023/1542 Article 10 - Performance and durability requirements for rechargeable industrial batteries, LMT batteries and electric vehicle batteries
- Regulation (EU) 2023/1542 Article 14 - Information on the state of health and expected lifetime of batteries
- Waste Electrical and Electronic Equipment 2012/19/EU
- Registration, Evaluation, Authorization and Restriction of Chemicals (EC) No 1907/2006 (REACH)

*1: Our company's battery products meet the hazardous substance limit

requirements specified in this regulation.

More EU compliance declarations can be obtained from the [official website](#).

2 System Introduction

2.1 System Overview

The residential smart inverter solution integrates devices such as inverters, batteries, smart meters, smart communication sticks, etc. In the photovoltaic system, it converts solar energy into electrical energy to meet household electricity demands. The energy IoT devices in the system control the power-consuming devices by identifying the overall electricity situation in the system, thereby achieving intelligent management of electricity for load use, storage to batteries, or output to the grid, etc.

WARNING

- Battery models should be selected based on the inverter and battery compatibility list. For requirements on batteries used in the same system, such as whether models can be mixed, whether capacities should be consistent, etc., please refer to the user manual of the corresponding battery model or contact the battery manufacturer for relevant requirements. Inverter and battery compatibility list:
https://en.goodwe.com/Ftp/EN/Downloads/User%20Manual/GW_Battery%20Compatibility%20Overview-EN.pdf.
- Due to product version upgrades or other reasons, the document content will be updated periodically. The compatibility relationship between inverters and IoT products can be referred to:
https://en.goodwe.com/Ftp/EN/Downloads/User%20Manual/GW_Compatibility-list-of-GoodWe-inverters-and-IoT-products-EN.pdf.
- Photovoltaic systems are not suitable for connecting devices that rely on stable power supply, such as life-sustaining medical equipment, etc. Please ensure that system power failure does not cause personal injury.
- If no battery is configured in the photovoltaic system, it is not recommended to use the BACK-UP function, otherwise it may cause system power failure risk.
- The BACK-UP port does not support connecting auto-transformers or isolation transformers.
- Battery current may be affected by some factors, such as: temperature, humidity,

WARNING

weather conditions, etc., which may cause battery current limiting and affect load capacity.

- The maximum discharge current and charging current of the battery are limited by the inverter connected to it.
- The inverter has UPS function, with switching time < 10ms. Please ensure that the BACK-UP load capacity < inverter rated power. Otherwise, it may cause the UPS function to fail during grid power failure.
- If no battery is configured in the photovoltaic system, it is not recommended to use the BACK-UP function, otherwise it may cause system power failure risk.
- When the inverter is in off-grid state, it can be used normally for ordinary household loads. However, the following loads need to be limited, such as:
 - inductive load: inductive load power < 0.4 times the inverter rated output power.
 - Capacitive load: total power $\leq 0.66 \times$ inverter rated output power.
 - The inverter does not support half-wave loads. Half-wave load: some old or non-compliant EMC standard household appliances (such as hair dryers, small heaters using half-wave rectification, etc.) may not work properly.
- In a system where the inverter operates completely off-grid, if the battery is in low light or rainy weather for a long time and fails to replenish power in time, it may lead to over-discharge, causing battery performance degradation or damage. To ensure long-term stable operation of the system, avoid the battery being completely drained. Recommended measures are as follows:
 1. When operating off-grid, set the minimum SOC protection threshold. It is recommended to set the off-grid battery SOC lower limit to 30%.
 2. When SOC approaches the protection threshold, the system will automatically enter current limiting or protection mode.
 3. If there is insufficient light for several consecutive days and the battery SOC is too low, promptly replenish energy for the battery through external energy sources (such as generators or grid-assisted charging).
 4. Regularly check the battery status to ensure it is within the safe operating range.
 5. It is recommended to fully charge and discharge the battery every six months to calibrate the SOC accuracy.
- For detailed networking and wiring schemes for each scenario, please refer to: [5.2.Detailed System Wiring Diagram\(Page 88\)](#).

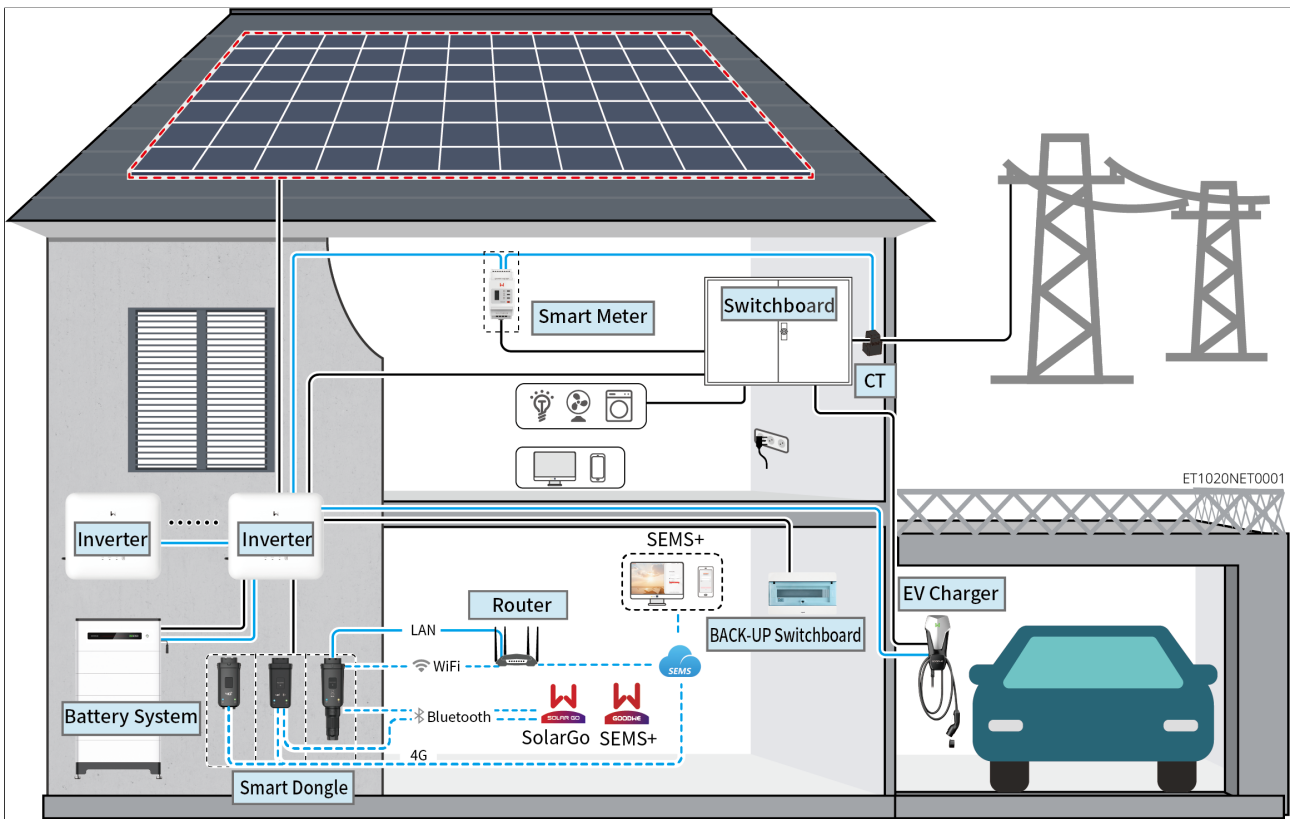

Figure1 System Networking Diagram

Device Type	model	Description
Inverter	GW6000-ET-20 GW8000-ET-20 GW9900-ET-20 (Australia only) GW10K-ET-20 GW12K-ET-20 GW15K-ET-20	<ul style="list-style-type: none"> • Supports up to 4 inverters to form a parallel system. Supports up to 4 inverters to form a parallel system. Supports mixing inverters of different power ratings in parallel. • All inverters in the parallel system must have the same software version. • In a coupled scenario, using a dual meter allows simultaneous monitoring of grid-tied inverter generation and load consumption. <ul style="list-style-type: none"> ◦ Inverter ARM software version 15.441 or higher. ◦ Inverter DSP software version 03.3009. ◦ SolarGo version 6.8.0 or higher.

Device Type	model	Description
Battery system	Lynx Home F G2 LX F9.6-H-20 LX F12.8-H-20 LX F16.0-H-20 LX F19.2-H-20 LX F22.4-H-20 LX F25.6-H-20 LX F28.8-H-20	<ul style="list-style-type: none"> • Lynx Home F battery system does not support clustering in parallel. • Clustering in parallel for capacity expansion between different models of Lynx Home Plus+ and Lynx Home F G2 batteries is temporarily not supported. Clustering in parallel for capacity expansion is allowed within one year of purchase for the same model, but not allowed after one year. • The Lynx Home Plus+ and Lynx Home F G2 battery systems support a maximum of 8 clusters in parallel. • Battery systems of different versions cannot be mixed.
	Lynx Home F, Lynx Home Plus+ LX F6.6-H LX F9.8-H LX F13.1-H LX F16.4-H	
	Lynx Home D LX D5.0-10	<ul style="list-style-type: none"> • LX D5.0-10 battery supports clustering in parallel and capacity expansion. • The battery system supports a maximum of 8 clusters in parallel.

Device Type	model	Description
Smart Meter	<ul style="list-style-type: none"> • GM3000 (purchased from GoodWe) • GM330 (purchased from GoodWe) • Built-in inverter meter 	<ul style="list-style-type: none"> • Built-in meter: Please use the CT shipped with the unit to connect to the inverter. <ul style="list-style-type: none"> ◦ The CT ratio is 90A/90mA. ◦ If the built-in inverter meter is insufficient, contact your dealer to purchase a GM330 or GM3000 smart meter. • GM3000: CT cannot be replaced. CT ratio: 120A: 40mA • GM330: CT can be purchased from GoodWe or separately. CT ratio requirement: nA/5A <ul style="list-style-type: none"> ◦ nA: CT primary side input current, where n ranges from 200-5000 ◦ 5A: CT secondary side output current
Smart Dongle	<ul style="list-style-type: none"> • WiFi/LAN Kit-20 • LS4G Kit-CN, 4G Kit-CN, 4G Kit-CN-G20 or 4G Kit-CN-G21 (China only) • Ezlink3000 	<ul style="list-style-type: none"> • For a single unit, use the WiFi/LAN Kit-20, LS4G Kit-CN, 4G Kit-CN, 4G Kit-CN-G20, or 4G Kit-CN-G21 module. • In a parallel system, only the master inverter needs to be connected to Ezlink3000; slave inverters do not require a communication module. • The firmware version for Ezlink3000 must be 04 or higher.

2.2 Product Overview

2.2.1 Inverter

The inverter in a photovoltaic system controls and optimizes energy flow through an integrated energy management system. It enables the generated electricity to be used for loads, stored in batteries, or fed into the grid.

NOTICE

Inverters of different power ranges may vary in appearance. Please refer to the actual product.

No.	model	Nominal output power	Nominal output voltage	Number of MPPTs
1	GW6000-ET-20	6kW	400/380, 3L/N/PE	2
2	GW8000-ET-20	8kW		2
3	GW9900-ET-20(Australia only)	9.9kW		3
4	GW10K-ET-20	10kW		3
5	GW12K-ET-20	12kW		3
6	GW15K-ET-20	15kW		3

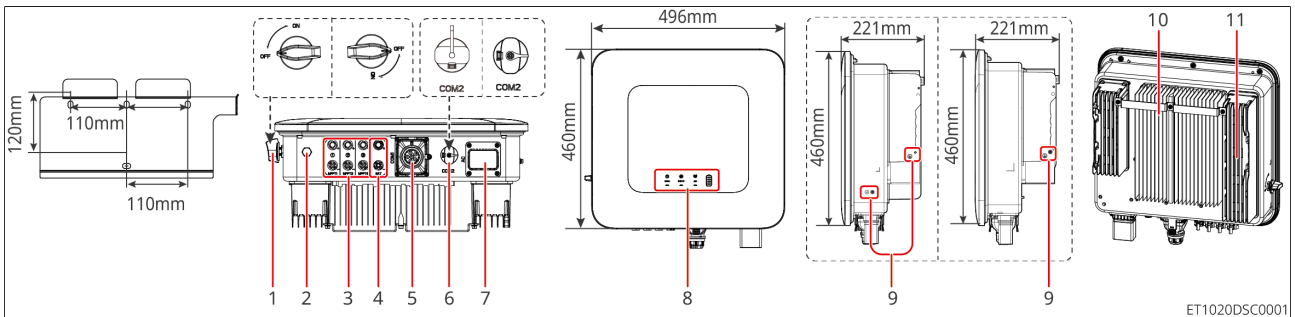

Figure2 Component Introduction

No.	Component	Description
1	DC Switch	Controls the connection or disconnection of the DC input.
2	Ventilation valve	-

No.	Component	Description
3	PV DC Input Port	Can connect PV module DC input cables. <ul style="list-style-type: none"> • GW6000-ET-20 and GW8000-ET-20: MPPT x 2 • GW9900-ET-20, GW10K-ET-20, GW12K-ET-20, GW15K-ET-20: MPPT x 3
4	Battery Connection Port	Connects battery DC cables.
5	Communication Port	Connects communication cables, supports communication with CT, meter, DRED, Remote Shutdown, Rapid Shutdown, RCR, EMS, generator, and BMS.
6	Communication Module Port	<ul style="list-style-type: none"> • Can connect communication modules, supports connecting to 4G, Wi-Fi/LAN modules. • Use a USB drive for system software upgrades.
7	AC Port	Connects AC cables.
8	indicator	Indicates the working status of the inverter.
9	Grounding terminal	Connects the protective grounding wire for the enclosure.
10	Mounting Bracket	For mounting the inverter.
11	heat sink	Dissipates heat for the inverter.

2.2.2 Battery

Battery system can store and release electrical energy based on the requirements of the photovoltaic energy storage system. The input and output ports of this energy storage system are both high-voltage direct current.

2.2.2.1 Lynx Home F, Lynx Home F Plus+

Lynx Home F series battery system consists of a master control box and battery

modules. The battery system can store and release electrical energy according to the requirements of the photovoltaic energy storage system. The input and output ports of this energy storage system are high-voltage direct current.

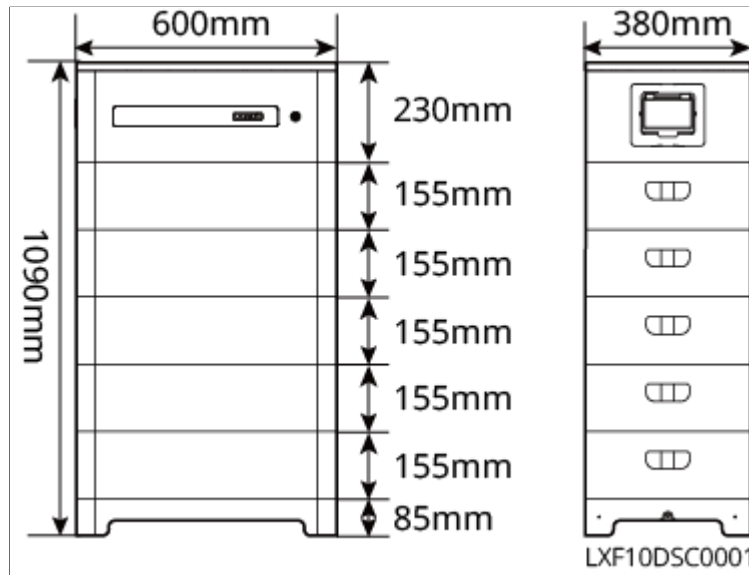
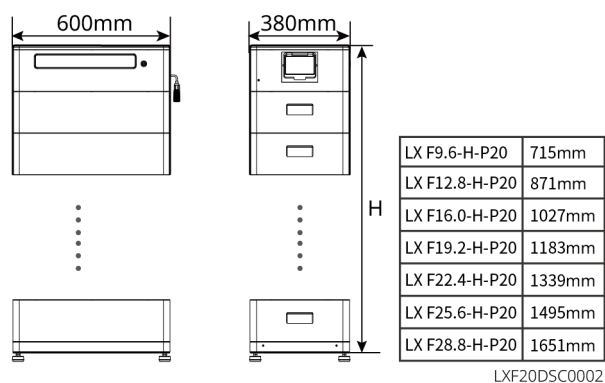

Figure3 Battery Dimensions

No.	model	Number of battery modules	usable energy (kWh)
1	LX F6.6-H	2	6.55kWh
2	LX F9.8-H	3	9.83kWh
3	LX F13.1-H	4	13.1kWh
4	LX F16.4-H	5	16.38kWh

2.2.2.2 Lynx Home F G2



No.	model	Number of battery modules	usable energy (kWh)
1	LX F9.6-H-20	3	9.6kWh
2	LX F12.8-H-20	4	12.8kWh
3	LX F16.0-H-20	5	16.0kWh
4	LX F19.2-H-20	6	19.2kWh
5	LX F22.4-H-20	7	22.4kWh
6	LX F25.6-H-20	8	25.6kWh
7	LX F28.8-H-20	9	28.8kWh

2.2.2.3 Lynx Home D

In the Lynx Home D battery system, the BMS and battery modules are integrated into one unit.

NOTICE

Can be installed with optional base or bracket.

Appearance Description:

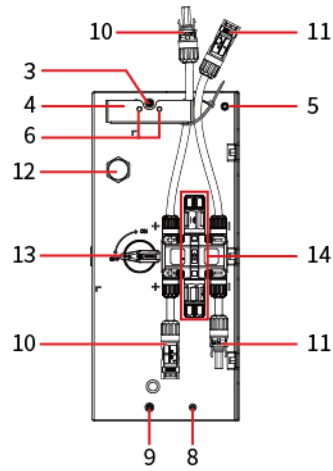
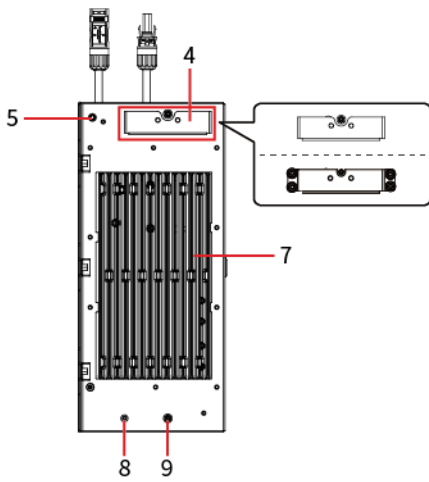
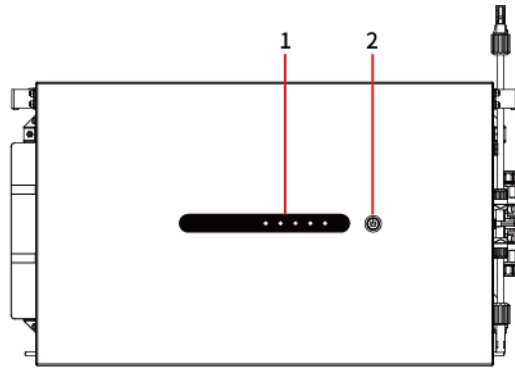

LXD10DSC0004

No.	Component	Description
1	Battery SOC Indicator	

No.	Component	Description
2	Multifunction Button Indicator	<ul style="list-style-type: none"> • SOC Indicator: Displays the battery SOC status. • Multifunction Button Indicator <ul style="list-style-type: none"> ◦ Battery Black Start Function: When there is no power generation from PV in the solar system and the grid is abnormal, if the inverter cannot operate normally, you can press and hold the multifunction button for 2 seconds to start the battery system and the inverter. The inverter can then enter off-grid mode, powered by the battery to supply the load. ◦ Press and hold the multifunction button for >5 seconds to power down the battery system. • When the SOC indicator and the multifunction button indicator display in combination, they can show the battery system's operating status, alarm status, and fault status.
3	Inter-battery Mounting Hole or Grounding Port	Used for securing two batteries together or for connecting the ground wire.
4	Handle	Used for carrying the battery.
5	Battery-to-Wall Mounting Hole	Used for securing the battery to the wall.
6	Side Cover Mounting Hole	Used for installing the side cover.
7	Heat Sink	Used for dissipating heat from the battery system.
8	Side Cover Mounting Hole	Used for installing the side cover.
9	Inter-battery Mounting Hole	Used for securing two batteries together.

No.	Component	Description
10	Battery Positive Connection Terminal	Connects to the positive terminal of the battery or inverter.
11	Battery Negative Connection Terminal	Connects to the negative terminal of the battery or inverter.
12	Ventilation Valve	Used to balance pressure inside and outside the battery.
13	Battery Power Switch	Battery power input/output switch.
14	Communication Connection Port	Connects communication cables or termination resistors between the battery and inverter, or between batteries.

Single Battery Dimensions:

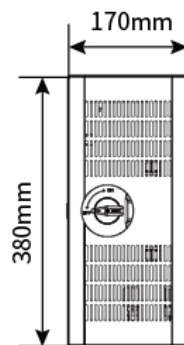
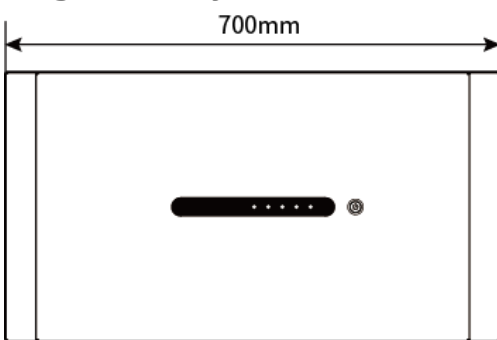

LXD10DSC0005

Battery Pack Dimensions:

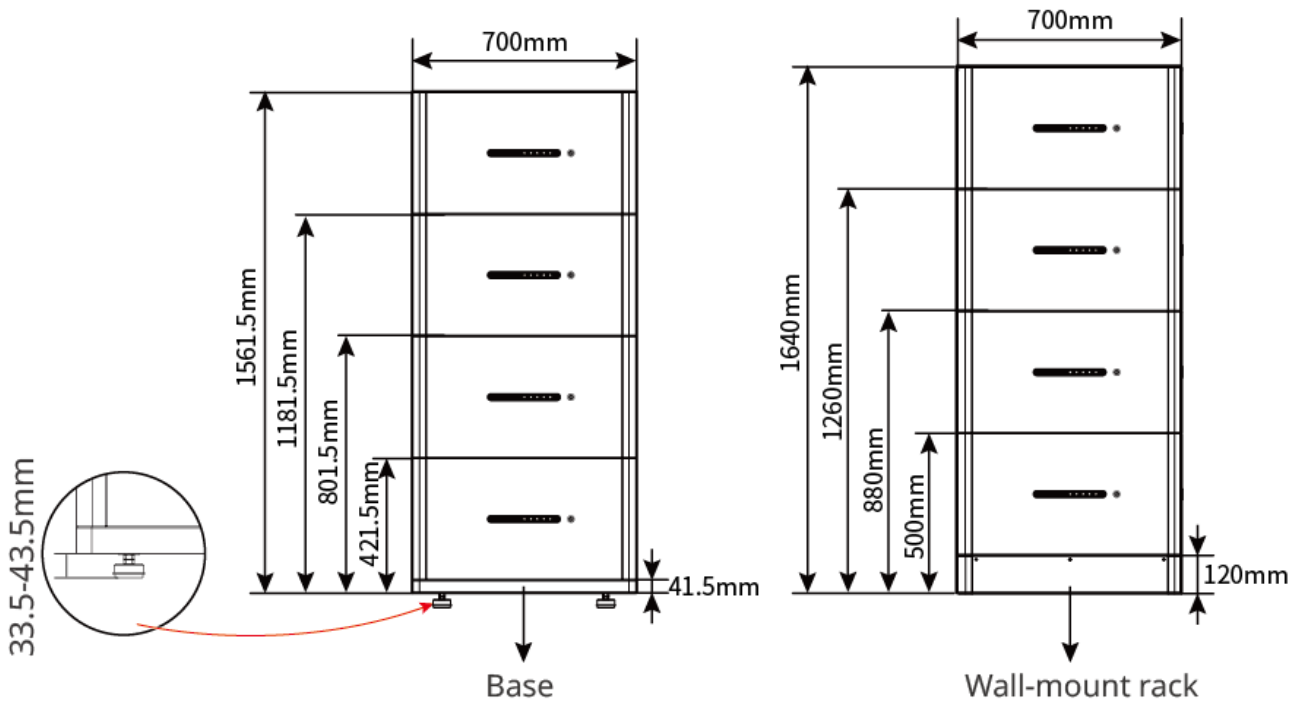

LXD10DSC0008

2.2.3 Smart Meter

The Smart Meter can measure parameters such as grid voltage, current, Power, Frequency, and electrical energy, and transmit this information to the inverter to control the input and output Power of the energy storage system.

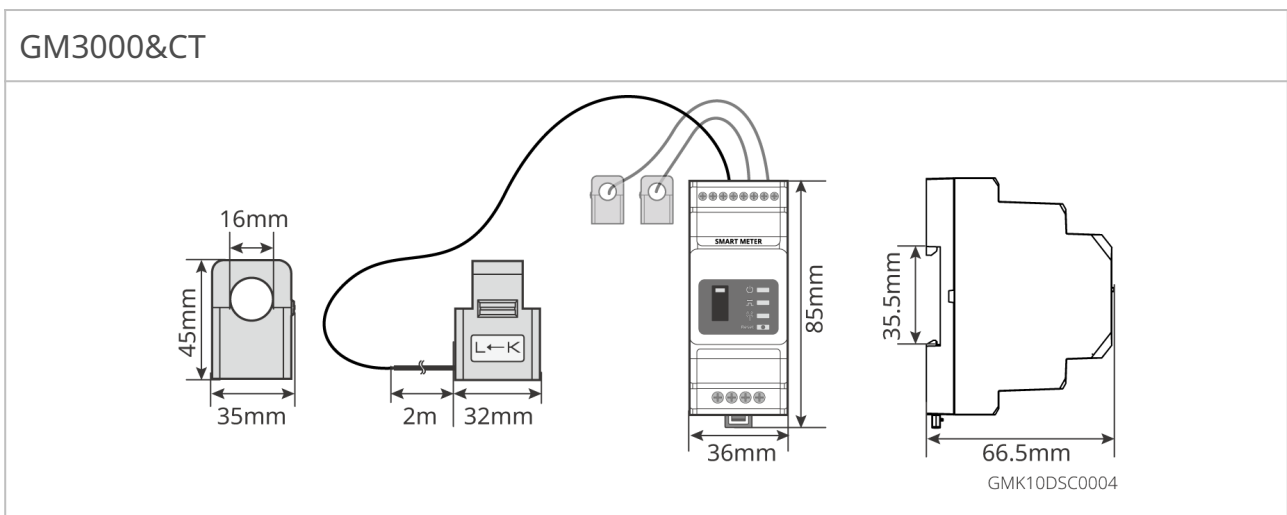

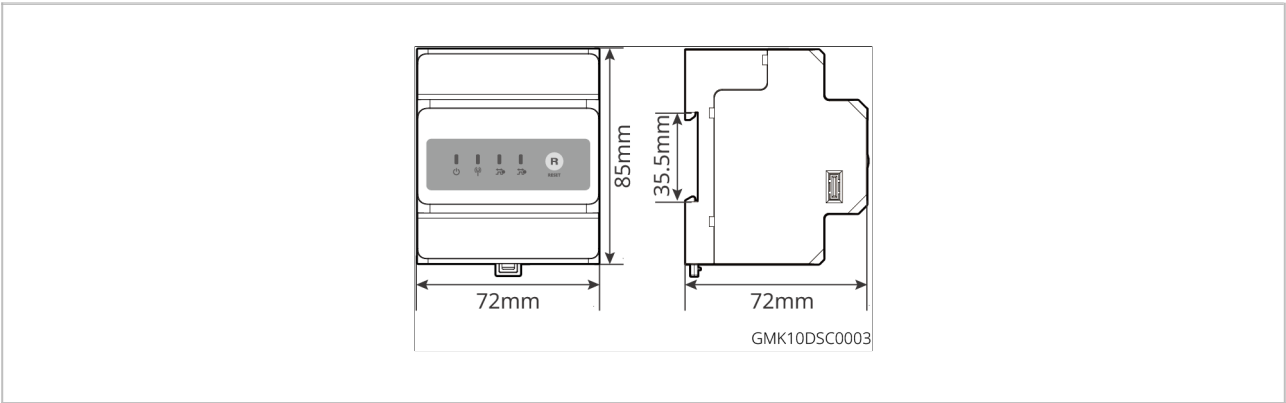

No.	model	Applicable Scenarios
1	GM3000	CT replacement not supported, CT ratio: 120A: 40mA
2	GM330	CT can be purchased from GoodWe or independently, CT ratio requirement: nA: 5A <ul style="list-style-type: none"> • nA: CT primary side input current, n range is 200-5000 • 5A: CT secondary side output current

2.2.4 Smart Dongle

The Smart Dongle is primarily used for real-time transmission of various inverter power generation data to the SEMS Portal remote monitoring platform, and for connecting to the Smart Dongle via the SolarGo APP for local device commissioning and debugging.

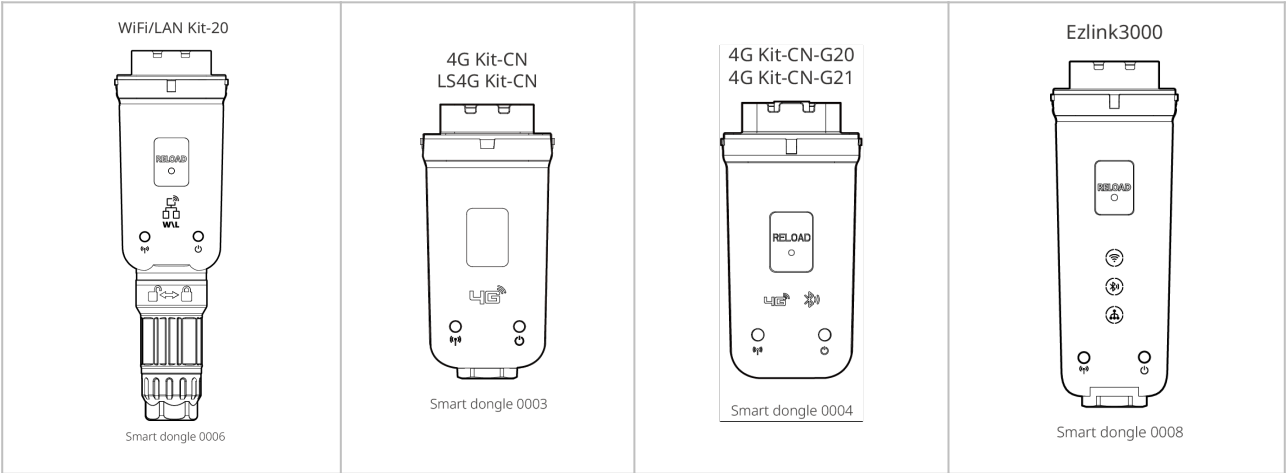

No.	model	Signal Type	Applicable Scenario
1	WiFi/LAN Kit-20	WiFi, LAN, Bluetooth	Single Inverter Scenario
2	4G Kit-CN LS4G Kit-CN	4G	
3	4G Kit-CN-G20 4G Kit-CN-G21	4G, Bluetooth 4G, Bluetooth, GNSS	
4	Ezlink3000	WiFi, LAN, Bluetooth	Master Unit in Multi-Inverter Scenario

2.3 Supported Grid Types

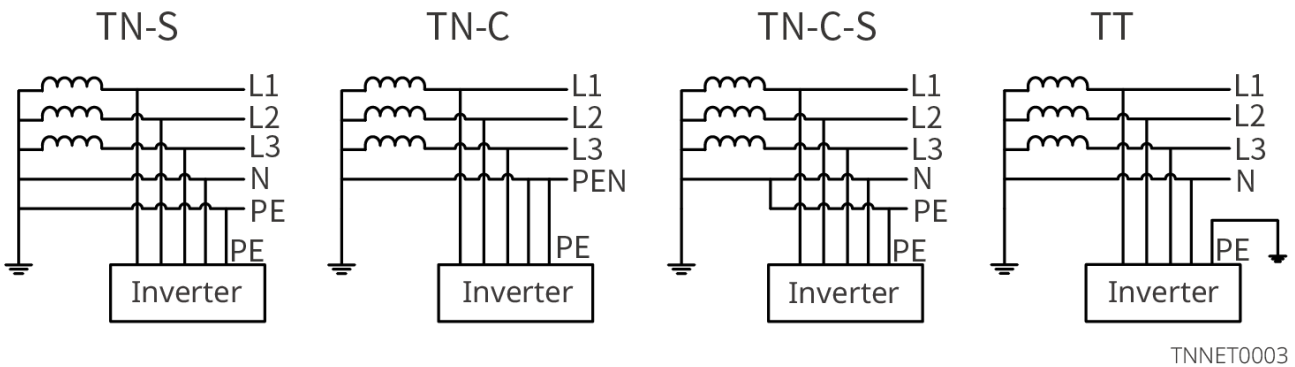

2.4 System Working Mode

Self-consumption

- The basic working mode of the system.
- PV-generated power is prioritized to supply the loads. Excess power charges the battery. Any remaining power is sold to the grid. When PV generation cannot meet the load demand, the battery supplies power to the loads. When the battery power is also insufficient to meet the load demand, the grid supplies power to the loads.

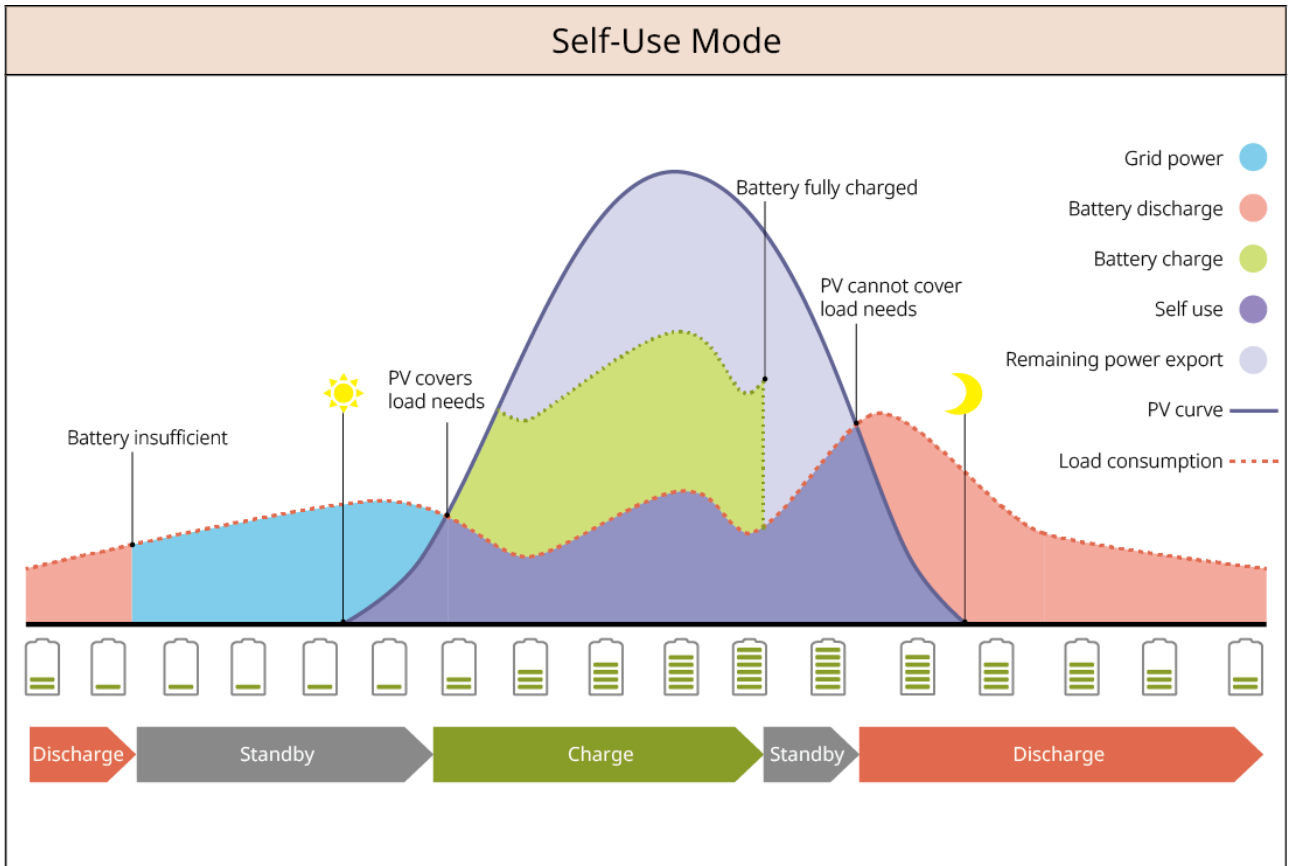

SLG00NET0009

Backup Mode

- Recommended for use in areas with unstable grid.
- When the grid fails, the inverter switches to off-grid working mode, and the battery discharges to supply power to the loads, ensuring uninterrupted power for the BACK-UP Loads. When the grid is restored, the inverter switches back to grid-connected operation.
- To ensure the battery SOC is sufficient for normal system operation during off-grid periods, the system will charge the battery using PV or by purchasing power from the grid to reach the backup power SOC during grid-connected operation. If purchasing power from the grid to charge the battery, please ensure it complies with local grid regulations and laws.

Back-up Mode ①

Charging from grid: disabled

Back-up SOC: 60%

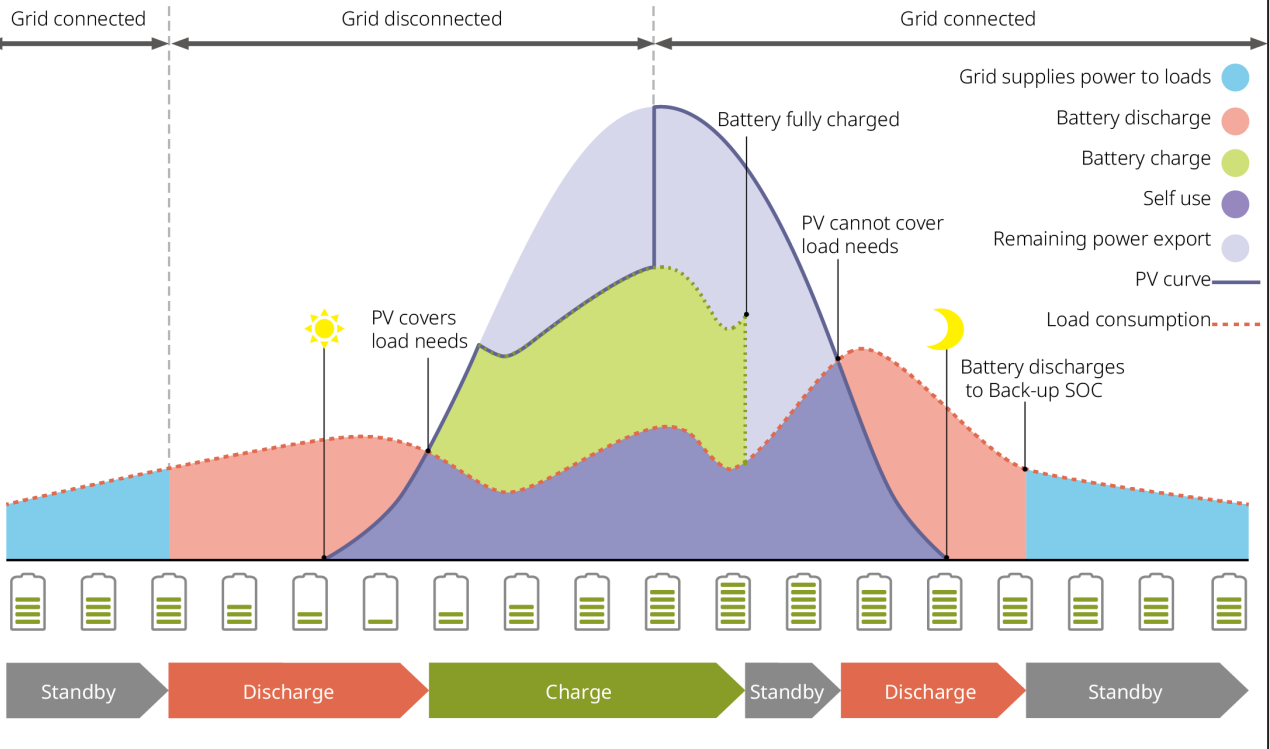

SLG00NET0002

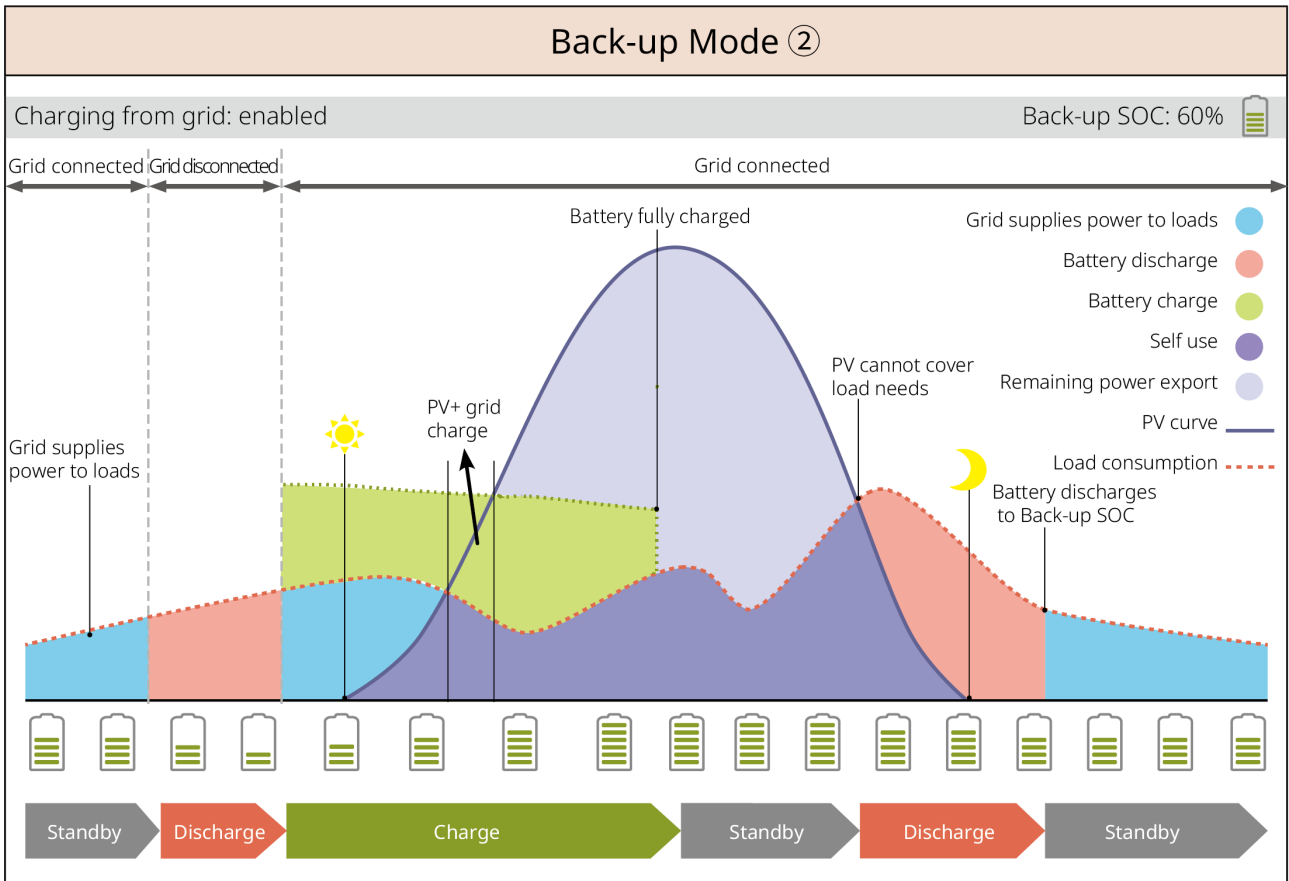

TOU Mode

Subject to local laws and regulations, electricity purchase and sale are set for different time periods based on peak and valley grid electricity price differences. For example: During valley price periods, set the battery to charging mode to purchase electricity from the grid for charging. During peak price periods, set the battery to discharging mode to supply power to the loads via the battery.

TOU Mode ①

PV: Charge battery in priority

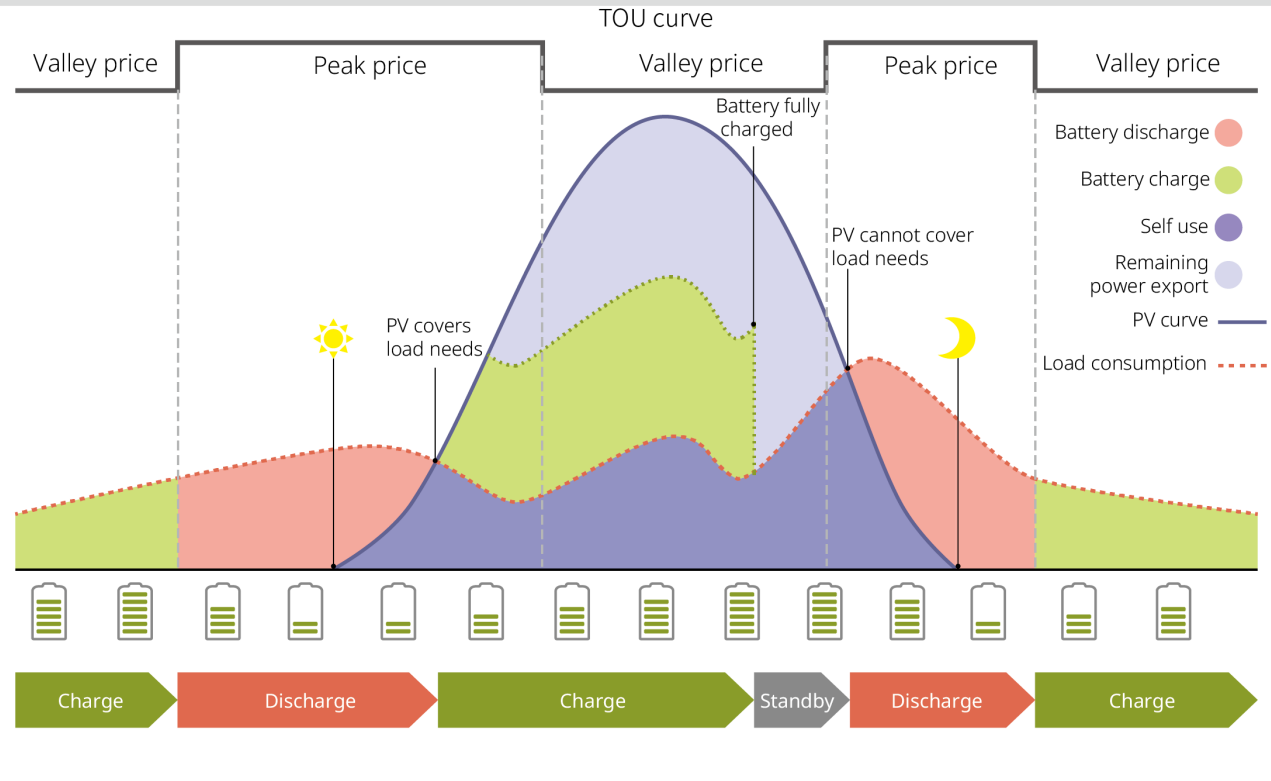

SLG00NET0004

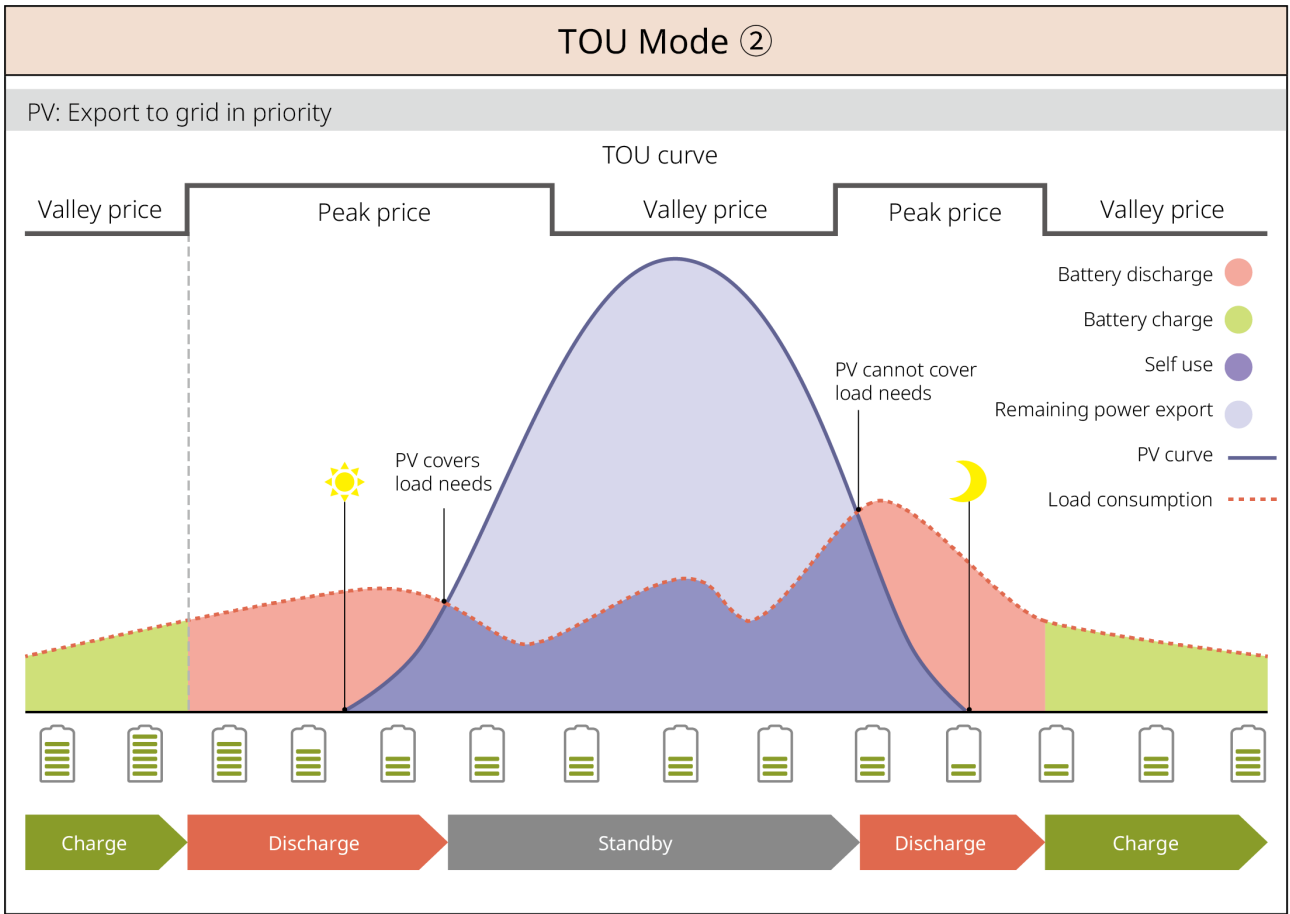

SLG00NET0005

Delayed Charging Mode

- Suitable for areas with grid-connected power output limitations.
- Setting a peak power limit allows excess PV generation beyond the grid-connection limit to be used for charging the battery; or setting PV charging time periods allows using PV generation to charge the battery during those periods.

Delayed Charging ①

PV > Peak Limit

Switch to Charge: enabled/disabled

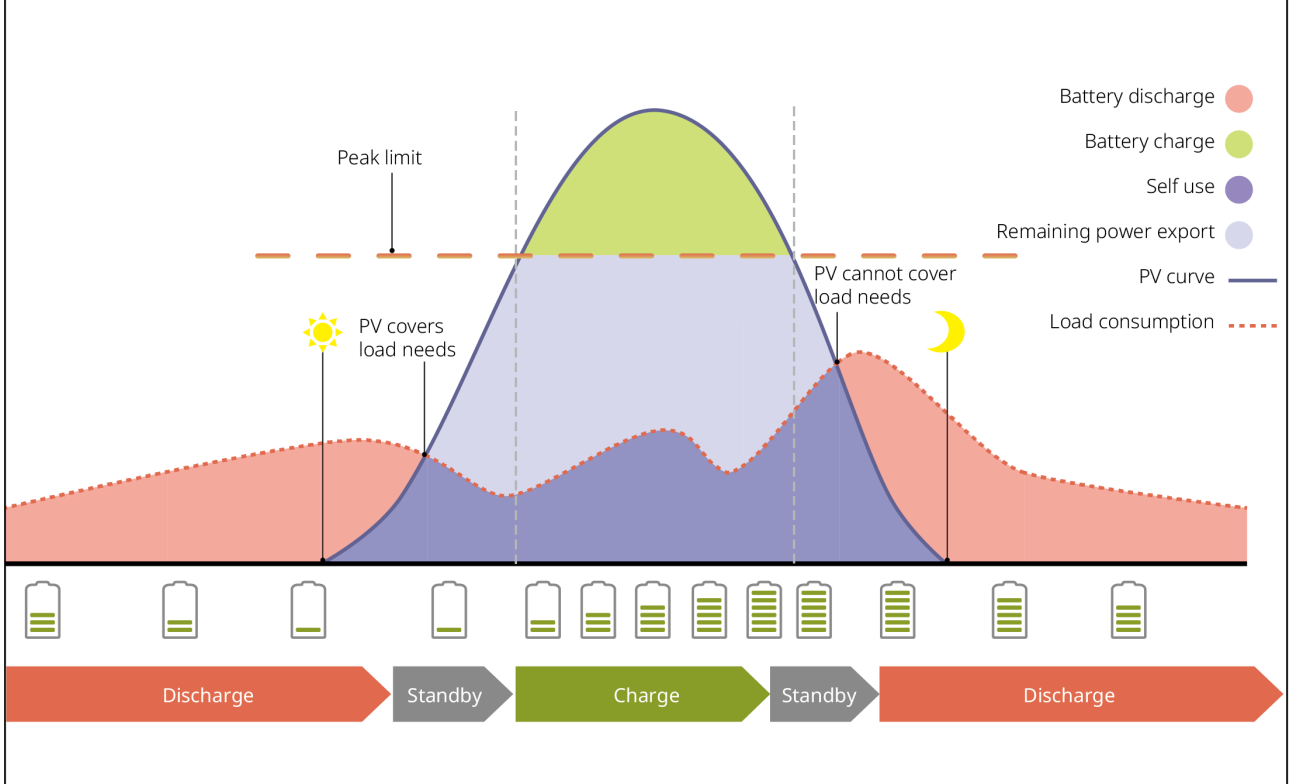

SLG00NET0006

Delayed Charging ②

PV < Peak Limit

Switch to Charge: enabled

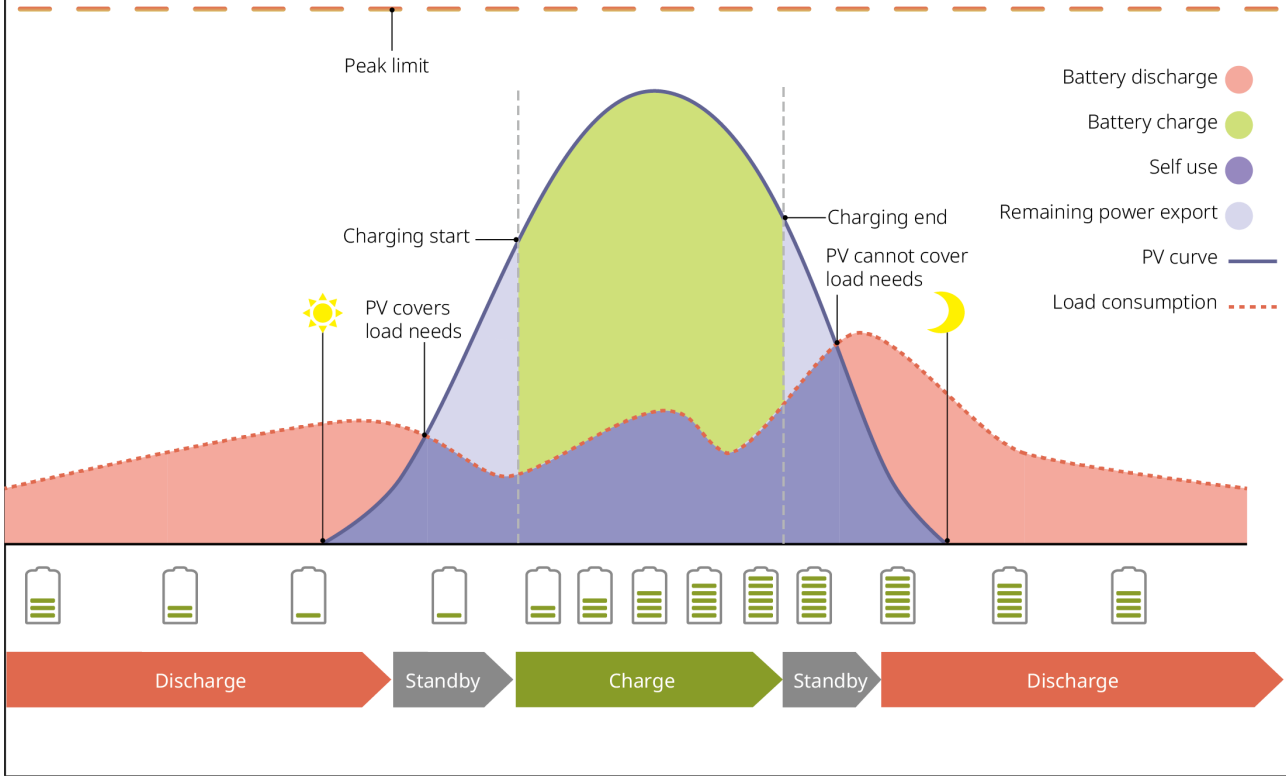

SLG00NET0007

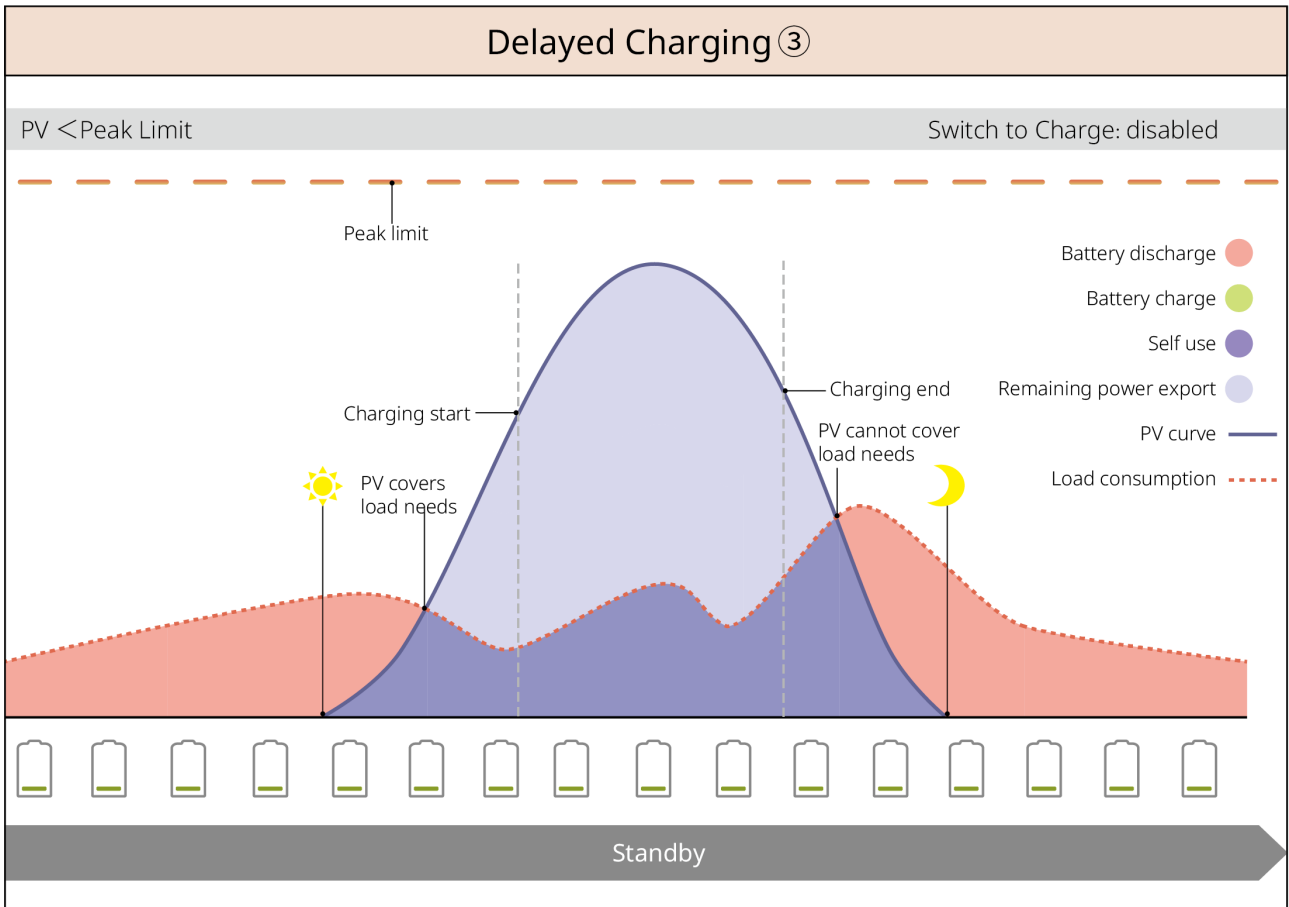

SLG00NET0008

Peakshaving Mode

- Primarily suitable for commercial and industrial scenarios.
- When the total load power consumption exceeds the electricity quota within a short period, battery discharge can be utilized to reduce the portion of consumption exceeding the quota.
- When the battery SOC is lower than the reserved SOC for peakshaving, the system purchases electricity from the grid based on the time period, load consumption, and the purchase power peak limit.

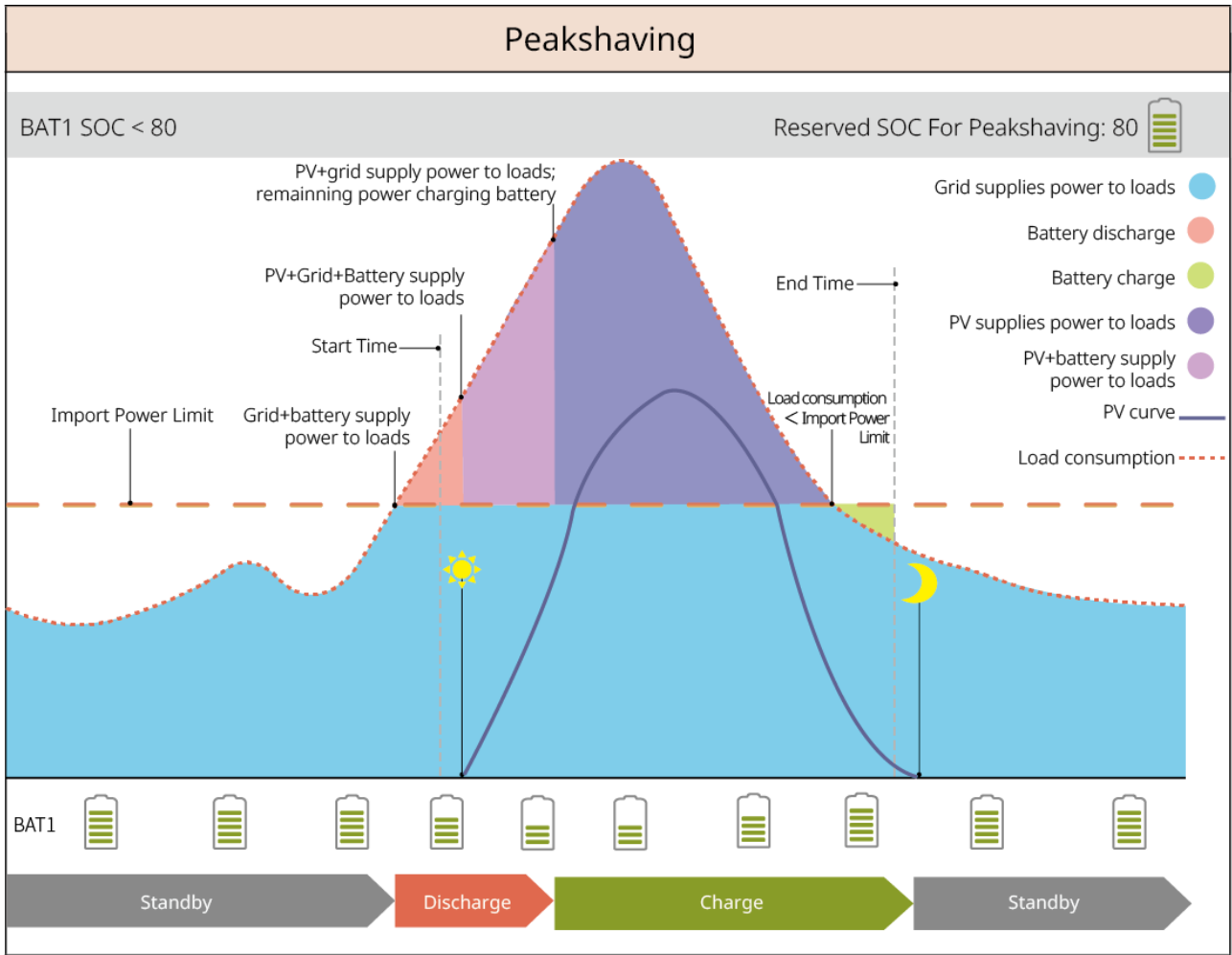

Off-grid Mode

NOTICE

Do not operate in pure off-grid mode when the inverter is not connected to the battery system.

When the grid fails, the inverter switches to off-grid working mode.

- During the day, PV-generated power is prioritized to supply the loads, with excess power charging the battery.
- At night, the battery discharges to supply power to the loads, ensuring uninterrupted power for the BACK-UP Loads.

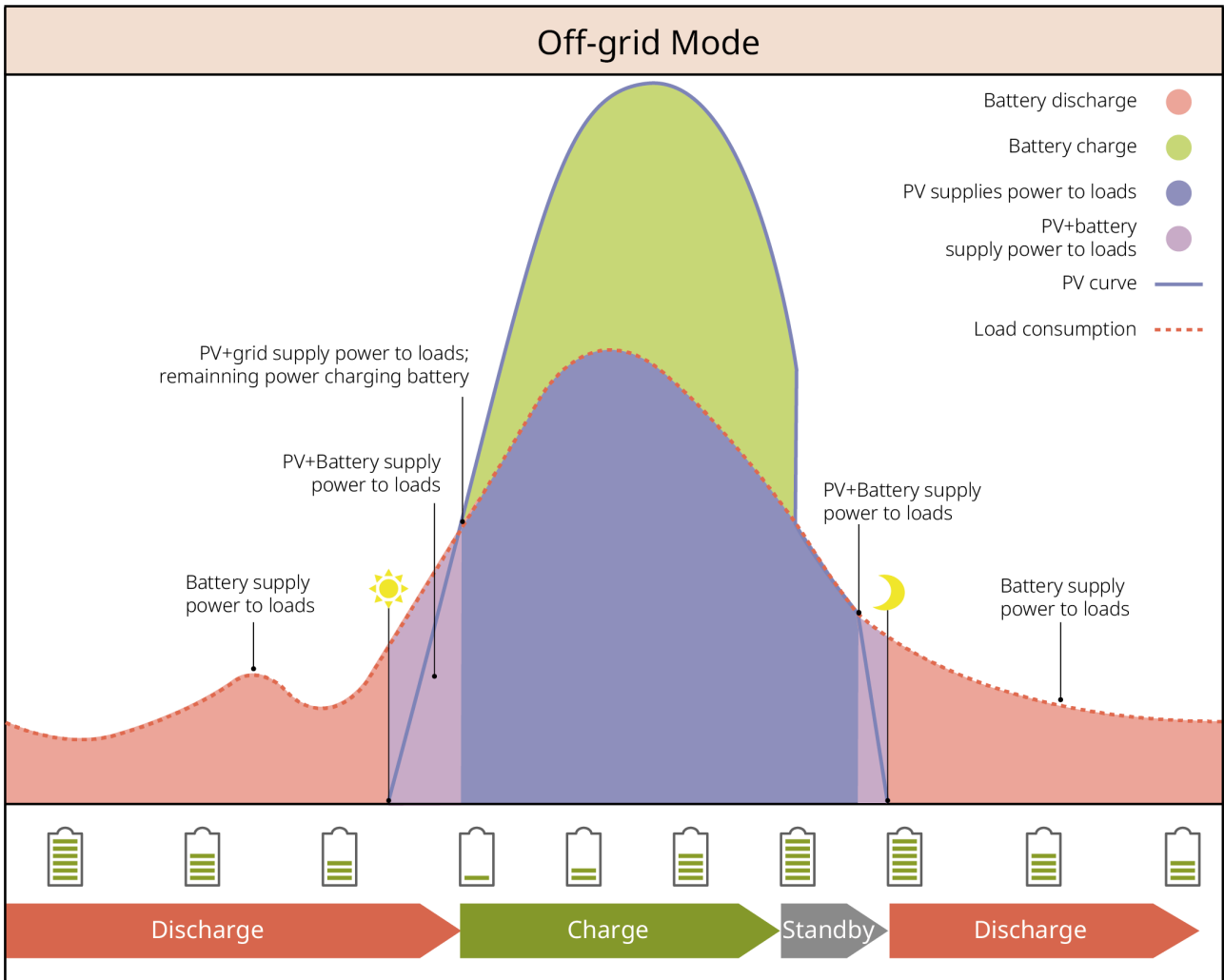

SLG00NET0012

2.5 Features

NOTICE

Specific functional features are subject to the actual product configuration.

AFCI Function

The inverter integrates an AFCI circuit protection device, which detects arc faults and rapidly cuts off the circuit upon detection, thereby preventing electrical fires.

Causes of arc faults:

- Damaged connections in the PV system or battery system.
- Incorrect or damaged cable connections.

- Aging connectors or cables.

Arc Detection Method

- The inverter integrates the AFCI function, complying with the IEC 63027 standard.
- When the inverter detects an arc fault, the time and fault phenomenon can be displayed via the App.
- After the inverter triggers an AFCI alarm, it will shut down for protection. The inverter will automatically reconnect to the grid and resume operation after the alarm is cleared.
 - Automatic Reconnection: If the inverter triggers an AFCI alarm < 5 times within 24 hours, the alarm can be automatically cleared after five minutes, and the inverter will reconnect to the grid and resume operation.

Manual Reconnection: If the inverter triggers the 5th AFCI alarm within 24 hours, the alarm must be manually cleared before the inverter can reconnect to the grid and resume operation.

model	Label	Description
GW6000-ET-20 GW8000-ET-20	F-I-AFPE-1-2-1	F: Full coverage I: Integrated AFPE: Detection and interruption capability provided 1: 1 monitored string per input port 2: 2 input ports per channel 1: 1 monitored channel
GW9900-ET-20 GW10K-ET-20 GW12K-ET-20 GW15K-ET-20	F-I-AFPE-1-2/1-2	F: Full coverage I: Integrated AFPE: Detection and interruption capability provided 1: 1 monitored string per input port 2/1: 2/1 input ports per channel (AFD1: 2 , AFD2: 1) 2: 2 monitored channels

Three-Phase Unbalanced Output

The inverter's grid connection side and BACK-UP side both support three-phase

unbalanced output, allowing loads of different power ratings to be connected to each phase. The maximum output power per phase for different models is shown in the table below:

No.	model	Maximum Output Power per Phase
1	GW6000-ET-20	3kW
2	GW8000-ET-20	4kW
3	GW9900-ET-20 (Australia only)	5kW
4	GW10K-ET-20	5kW
5	GW12K-ET-20	5kW
6	GW15K-ET-20	5kW

load control

The inverter's dry contact control port supports connecting an additional contactor to control the switching on or off of loads. It supports household loads, heat pumps, etc.

Load control methods are as follows:

- Time Control: Set the time to turn the controlled load on or off. The load will automatically turn on or off within the set time period.
- Switch Control: When the control mode is set to ON, the load will turn on; when the control mode is set to OFF, the load will turn off.
- BACK-UP Loads Control: The inverter has a built-in relay dry contact control port, which can control whether a load is switched off via the relay. In off-grid mode, if the BACK-UP side is detected to be overloaded and the battery SOC value is below the set off-grid protection value, the load connected to the relay port can be switched off.

Rapid Shutdown (RSD)

In a rapid shutdown system, the rapid shutdown transmitter and receiver work together to achieve rapid system shutdown. The receiver maintains module output by receiving signals from the transmitter. The transmitter can be external or built into the inverter. In an emergency, by enabling an external triggering device, the transmitter can be deactivated, thereby shutting down the modules.

- External Transmitter

- Transmitter Models: GTP-F2L-20, GTP-F2M-20
<https://www.goodwe.com/Ftp/Installation-instructions/RSD2.0-transmitter.pdf>
- Receiver Models: GR-B1F-20, GR-B2F-20
https://en.goodwe.com/Ftp/EN/Downloads/User%20Manual/GW_RSD-20_Quick-Installation-Guide-POLY.pdf
- Built-in Transmitter
 - External Triggering Device: External switch
 - Receiver Models: GR-B1F-20, GR-B2F-20
https://en.goodwe.com/Ftp/EN/Downloads/User%20Manual/GW_RSD-20_Quick-Installation-Guide-POLY.pdf

3 Check and Storage

3.1 Check Before Receiving

Before receiving the product, please carefully check the following:

1. Check if the outer packaging is damaged, such as deformation, holes, cracks, or other signs that could cause damage to the equipment inside the box. If damaged, do not open the packaging and contact your dealer.
2. Check if the device model is correct. If it does not match, do not open the packaging and contact your dealer.



3.2 deliverables





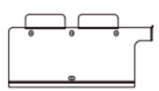

 **WARNING**

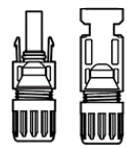

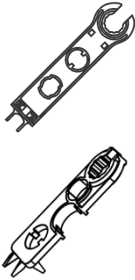
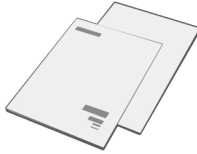
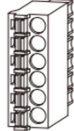
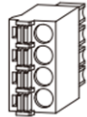
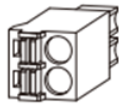

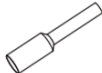
Check if the type and quantity of the delivered items are correct, and if there is any damage to the appearance. If damaged, please contact your dealer.
After removing the delivered items from the packaging, do not place them on rough, uneven, or sharp surfaces to avoid paint chipping.

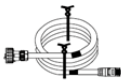

3.2.1 Inverter Deliverables

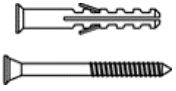
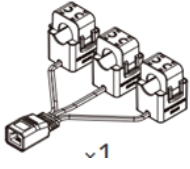
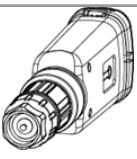
Inverter Deliverables

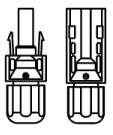
Part	Quantity	Part	Quantity
	Inverter x 1		Backplate x 1
	Back-mounting fastening screw x 1		PV connector GW6000-ET-20, GW8000-ET-20: 2 GW9900-ET-20, GW10K-ET-20, GW12K-ET-20, GW15K-ET-20: 3

Part	Quantity	Part	Quantity
 or	Wiring tool x 2		Product documentation x 1
	6PIN communication terminal x 1		4PIN communication terminal x 3
	2PIN communication terminal x 1		AC crimp terminal x 12
	Grounding terminal x 1		PIN terminal x 20
	AC terminal protective cover x 1		BMS Communication cable x 1
	Hexagon screwdriver x 1		CT connection cable x 1

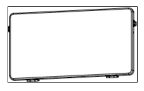
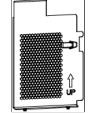
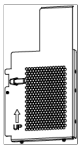
Part	Quantity	Part	Quantity
	expansion bolt x 4		CT x 1
	Smart Dongle x 1		screwdriver x 1
 Battery connector	(Optional) Battery connector x 2	 Battery connector Crimp terminal	(Optional) Battery connector x 1, Crimp terminal x 8

Component	Quantity	Component	Quantity
	Protective Cover Front Panel x 1		Protective Cover Left Side Panel x 1
	Protective Cover Right Side Panel x 1		Protective Cover Bottom Panel x 1

Component	Quantity	Component	Quantity
	expansion bolt x 4	-	-

Table35 Protective Cover Accessories (Australia Only)





3.2.2 Batteries Deliverables

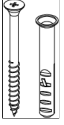

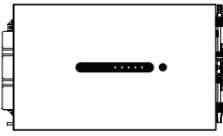

3.2.2.1 Batteries Deliverables (Lynx Home D)

NOTICE





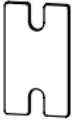

The battery system must be installed on a base or a mounting bracket. Please select the appropriate base or bracket according to the installation conditions. The actual delivery content is subject to the specific configuration selected.

- Battery



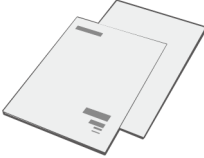
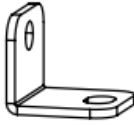

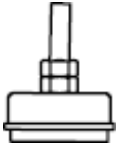
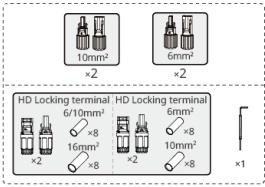

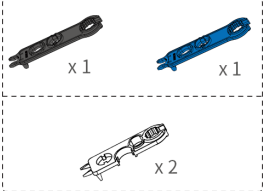

Part	Quantity	Part	Quantity
	Battery x 1		Battery left side protection cover x 1
	M6 screw x 2		Battery right side protection cover x 1

Part	Quantity	Part	Quantity
	<p>M5 screw</p> <ul style="list-style-type: none"> • When the battery inter-fixing bracket accessory is shipped, the quantity of M5 screws is 4. • When the battery inter-fixing bracket is installed on the machine for shipment, the quantity of M5 screws is 2. 		<p>M6 Expansion bolt x 2</p>
	<p>battery inter-fixing bracket</p> <ul style="list-style-type: none"> • When the battery inter-fixing bracket accessory is shipped, the shipment quantity is 2. • When the battery inter-fixing bracket is installed on the machine for shipment, the shipment quantity is 0. 		<p>battery inter-communication cable x 1</p>
	<p>locking bracket x 2</p>	-	-

- (Optional) Base

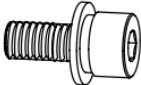
Part	Quantity	Part	Quantity
	Base x 1		M5screw x 2
	Product documentation x 1		Base and battery mounting bracket x 2
	Grounding terminal x 1		Adjustable foot x N The quantity of adjustable feet is subject to the actual shipment. If adjustable feet are not included in the actual delivered items and are required, please contact the distributor or after-sales service to obtain them.
	Power connection terminal (Optional) Hex key x 1 The hex key is shipped together with the battery DC terminal in the self-sealing bag labeled HD Locking terminal.		Terminal resistor x 1
	Power connection terminal tightening tool	-	-

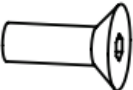

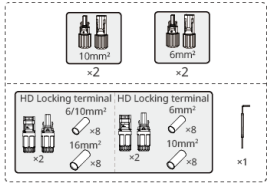
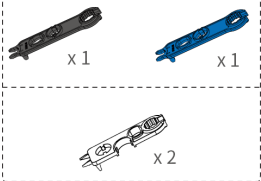
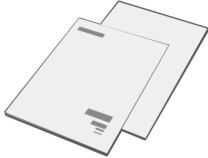

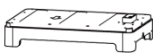

Mounting bracket (Optional)

Part	Quantity	Part	Quantity
	Bracket x 1		Front protective cover x 1
	Left protective cover x 1		Right protective cover x 1
	Bracket and battery fixing bracket x 2		M5 screw x 2
	M12 Expansion bolt x 4		M4 screw x 5
	Grounding terminal x 1		Terminal resistor x 1
 <p>Power connection terminal (Optional) Hex key x 1 The hex key is shipped with the battery DC terminal in the self-sealing bag labeled HD Locking terminal.</p>		 <p>Power connection terminal fastening tool</p>	
	Product documentation x 1	-	-

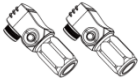
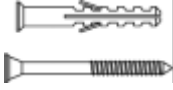
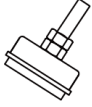
3.2.2.2 Lynx Home F 、Lynx Home F Plus+

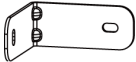
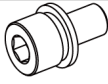
- Control Box Package

Component	Quantity	Component	Quantity
	Power control unit x 1		Base x 1

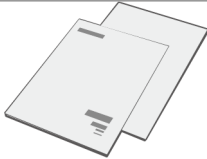
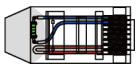



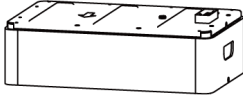

Component	Quantity	Component	Quantity
	DC Connector <ul style="list-style-type: none"> Lynx Home F x1 Lynx Home F Plus+ x 2 		Expansion bolt x 4
adjustable foot 	<ul style="list-style-type: none"> The adjustable foot is only included with the Lynx home F Plus+ series. If the adjustable foot is selected, the following quantities are supplied: <ul style="list-style-type: none"> adjustable foot: 4pcs Foot anti-tip bracket: 2pcs Standard anti-tip bracket: 2pcs If the adjustable foot is not selected, the following quantity is supplied: <ul style="list-style-type: none"> Standard anti-tip bracket: 4pcs 		
Foot anti-tip bracket 			
Standard anti-tip bracket 			
	M5*12screw x 4		M5hexalobular internal x 2
	M6nut x 2		Grounding terminal x 2
	Protective cover x 1		Product documentation x 1
	Terminal resistor x 1	-	-



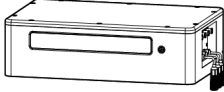

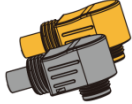
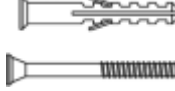
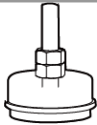
- Battery Module Package

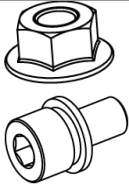
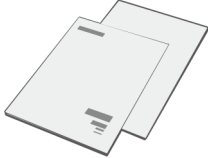
Part	Quantity
	battery module x 1

3.2.2.3 Lynx Home F G2

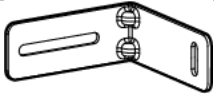
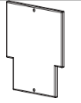
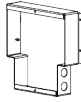
- Main Control Box Package



Part	Quantity	Part	Quantity
	Power control unit x 1		Base x 1
	DC Connector Positive: x 2 Negative: x 2		Expansion bolt x 8
	adjustable foot x 4		Grounding terminal x 2
	<ul style="list-style-type: none"> • M5*12 screw x N • M6 nut x N <p>N: The quantity depends on the product configuration:</p> <ul style="list-style-type: none"> • M5*12 screw x 8, M6 nut x 2; • M5*12 screw x 10, M6 nut x 2; • M5*12 screw x 11, M6 nut x 2; • M5*12 screw x 13, M6 nut x 0; • M5*12 screw x 12, M6 nut x 0; 		
	Product documentation x 1		(Optional) Protective cover plate x 1

Part	Quantity	Part	Quantity
	Lshaped bracket x 8	 Junction box cover plate  Junction box	(Optional) Junction box x 1, Junction box cover plate x 1,
	DC Connector waterproof plug x 4	 	DC Connector waterproof plug x 4

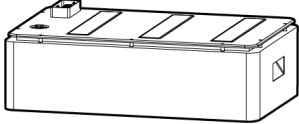

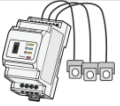
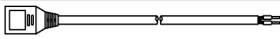
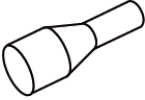

- Battery Module Package

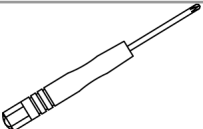
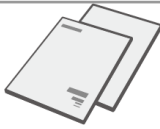
Component	Quantity
	battery module x 1

3.3 Smart Meter Deliverables (GM3000)

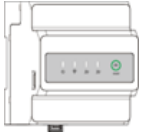
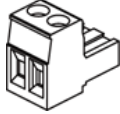
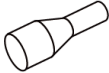
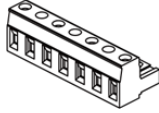
Part	Quantity	Part	Quantity
	Smart meter and CT x 1		2PIN terminal to RJ45 terminal adapter cable x 1
	PIN terminal x 3		USB plug x 1
	screwdriver x 1		Product documentation x 1

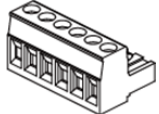
3.4 GM330



Part	Description	Part	Description
	Smart Meter and CT x1		2PIN communication terminal x1
	PIN terminal x 6		7PIN terminal x1
	screwdriver x1		6PIN communication terminal x1
	2PIN terminal to RJ45 terminal adapter cable x 1		Product documentation x 1

3.5 Smart Communication Stick Deliverables



LS4G Kit-CN&4G Kit-CN

Part	Description	Part	Description
	4GSmart Dongle x1	-	-

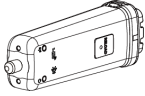

WiFi/LAN Kit-20

Part	Description	Part	Description
	Smart Dongle x1		Product Document x 1

4G Kit-CN-G20 & 4G Kit-CN-G21

Component	Description	Component	Description
	4G Smart Communication Stick x1		Product Documentation x1

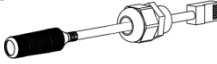
Ezlink3000

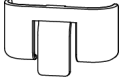
Part	Description	Part	Description
	Smart Dongle x1		LAN Cable Connection Port x1
	Product Documentation x1		Unlocking Tool x1 Some modules require a tool for disassembly. If not provided, the module can be unlocked using the button on the module body.

3.6 Storage

NOTICE

[1] The storage time is calculated from the SN date on the battery outer packaging. After exceeding the storage cycle, charge and discharge maintenance is required. (Battery maintenance time = SN date + charge and discharge maintenance cycle). For the method to view the SN date, refer to: [10.3.SN Code Meaning\(Page 242\)](#).

[2] After the charge and discharge maintenance is qualified, if there is a Maintaining Label on the outer box, please update the maintenance information on the Maintaining Label. If there is no Maintaining Label, please record the maintenance time and battery SOC by yourself and keep the data safe, to facilitate the preservation of maintenance records.

If the device is not put into use immediately, store it according to the following requirements. After long-term storage, the device must be inspected and confirmed by professionals before it can be used again.

1. If the inverter is stored for more than two years or not operated for more than 6

months after installation, it is recommended to be inspected and tested by professionals before putting it into use.

2. To ensure the good electrical performance of the internal electronic components of the inverter, it is recommended to power it on every 6 months during storage. If it has not been powered on for more than 6 months, it is recommended to be inspected and tested by professionals before use.
3. To protect battery performance and service life, it is recommended to avoid long-term idle storage. Prolonged storage may cause deep discharge of the battery, leading to irreversible chemical loss, capacity decay, or even complete failure. It is recommended to use it promptly. If the battery needs to be stored for a long time, maintain it according to the following requirements:

Battery Model	Initial SOC Range for Battery Storage	Recommended Storage Temperature	Charge/Discharge Maintenance Cycle ^[1]	Battery Maintenance Method ^[2]
LX F6.6-H	30%~50%	0~35°C	-20~0°C, ≤1 month	Please consult the dealer or after-sales service center for maintenance methods.
LX F9.8-H			0~35°C, ≤6 months	
LX F13.1-H			35~45°C, ≤1 month	
LX F16.4-H				
LX F9.6-H-20	30%~40%	0~35°C	-20~0°C, ≤1 month	
LX F12.8-H-20			0~35°C, ≤6 months	
LX F16.0-H-20			35~45°C, ≤1 month	
LX F19.2-H-20				
LX F22.4-H-20				
LX F25.6-H-20				
LX F28.8-H-20				
LX D5.0-10	30%~40%	0~35°C	-20~35°C, ≤12 months 35~+45°C, ≤6 months	

Packaging Requirements:

Ensure that the outer packaging box is not removed and the desiccant inside the box is not lost.

Environmental Requirements:

1. Ensure that the device is stored in a cool place, avoiding direct sunlight.

2. Ensure that the storage environment is clean, with appropriate temperature and humidity ranges, and no condensation. If there is condensation on the device ports, do not install the device.
3. Ensure that the device is stored away from flammable, explosive, corrosive, and other hazardous materials.

Stacking Requirements:

1. Ensure that the inverter stacking height and direction are arranged according to the instructions on the packaging box label.
2. Ensure that there is no risk of tipping after the inverters are stacked.

4 Installation



Please use the delivery items included in the shipment for equipment installation and electrical connection. Damage caused by using other components is not covered under warranty.

4.1 System Installation and Commissioning Procedure

Steps	1 Installation	2 PE	3 PV	4 Battery	5 AC	6 COM	7 Communication module					
Inverter												
Tools	D: 80mm φ: 8mm M5 1.2-2N·m	M5 1.5-2N·m	Recommend: PV-CZM-61100 	Recommend: VXC9 	M5 1.5-2N·m	M4 1.5N·m						
Steps	1 Installation				2 PE	3 Battery			4 COM			
Battery	Lynx Home F G2	Lynx Home F	Lynx Home F Plus+	Lynx Home D	Lynx Home F	Lynx Home D	Lynx Home F G2	Lynx Home F	Lynx Home F Plus+	Lynx Home D	Lynx Home F	Lynx Home D
Tools					M6 6-7N·m	M5 4N·m	Recommend: YQK-70 	Recommend: YQK-70 	Recommend: YQK-70 	Recommend: YQK-70 	Recommend: VXC9 	M5 1.5-2N·m
Steps	1 Installation		2 Cable Connections		3 Power	4 Commissioning						
Smart meter	GM3000	GM330	GM3000	GM330	AC breaker	 SolarGo APP or SEMS Portal+ APP SEMS Portal+ WEB						

Figure4

4.2 Installation Requirements

4.2.1 Installation Environment Requirements

NOTICE

Lynx home D:

- The operational noise of the battery primarily originates from the active cooling system, specifically an axial flow cooling fan optimized through fluid dynamics design.
- When the battery produces a regular airflow sound of $\leq 35\text{dB(A)}$: this indicates that the cooling system is in normal working condition, and it will not affect the electrical performance, structural safety, or service life of the device. If you are sensitive to noise, please choose an appropriate installation location.

1. The equipment must not be installed in flammable, explosive, corrosive, or similar environments.
2. The temperature and humidity of the installation environment must be within a suitable range.
3. The installation location must be out of reach of children and avoid easily accessible positions.
4. During Inverter operation, the enclosure temperature may exceed 60°C . Do not touch the enclosure before it cools down to prevent burns.
5. The equipment should be installed away from direct sunlight, rain, snow accumulation, and other such conditions. It is recommended to install in a sheltered location; a sunshade can be constructed if necessary.
6. Adverse environmental conditions such as direct sunlight and high temperatures may cause the Inverter's output power to derate.
7. The installation space must meet the equipment's ventilation, heat dissipation, and operational space requirements.
8. The installation environment must satisfy the equipment's protection rating. The Inverter, battery, and smart communication stick are suitable for both indoor and outdoor Installation; the meter is suitable for indoor Installation.
9. The equipment installation height should facilitate operation and maintenance, ensuring the equipment indicator lights, all labels are easily visible, and the wiring terminals are easy to operate.
10. The equipment installation altitude must be lower than the maximum operating altitude.
11. For outdoor Installation of equipment in salt damage areas, please consult the equipment manufacturer. Salt damage areas mainly refer to regions within 500m of the coast. The affected area is related to factors such as sea wind, precipitation, and terrain.

12. The DC cable and communication cable length between the battery and the Inverter must be less than 3m. Please ensure the installation distance between the Inverter and the battery meets the cable length requirement.
13. Keep away from strong magnetic field environments to avoid electromagnetic interference. If there is a radio station or wireless communication equipment operating below 30MHz near the installation site, install the equipment according to the following requirements:
 - Inverter: Add ferrite cores with multiple windings at the Inverter's DC input or AC output lines, or add a low-pass EMI filter; or maintain a distance of over 30m between the Inverter and the wireless electromagnetic interference equipment.
 - Other equipment: Maintain a distance of over 30m between the equipment and the wireless electromagnetic interference equipment.

NOTICE

If installed in an environment below 0°C, the battery will be unable to recharge and recover energy after being depleted, resulting in battery undervoltage protection.

- Lynx home F, Lynx home F Plus+, Lynx home F G2: Charging temperature range: $0 < T < 50^{\circ}\text{C}$; Discharging temperature range: $-20 < T < 50^{\circ}\text{C}$.
- Lynx home D: Charging temperature range: $0 < T < 53^{\circ}\text{C}$; Discharging temperature range: $-20 < T < 53^{\circ}\text{C}$.

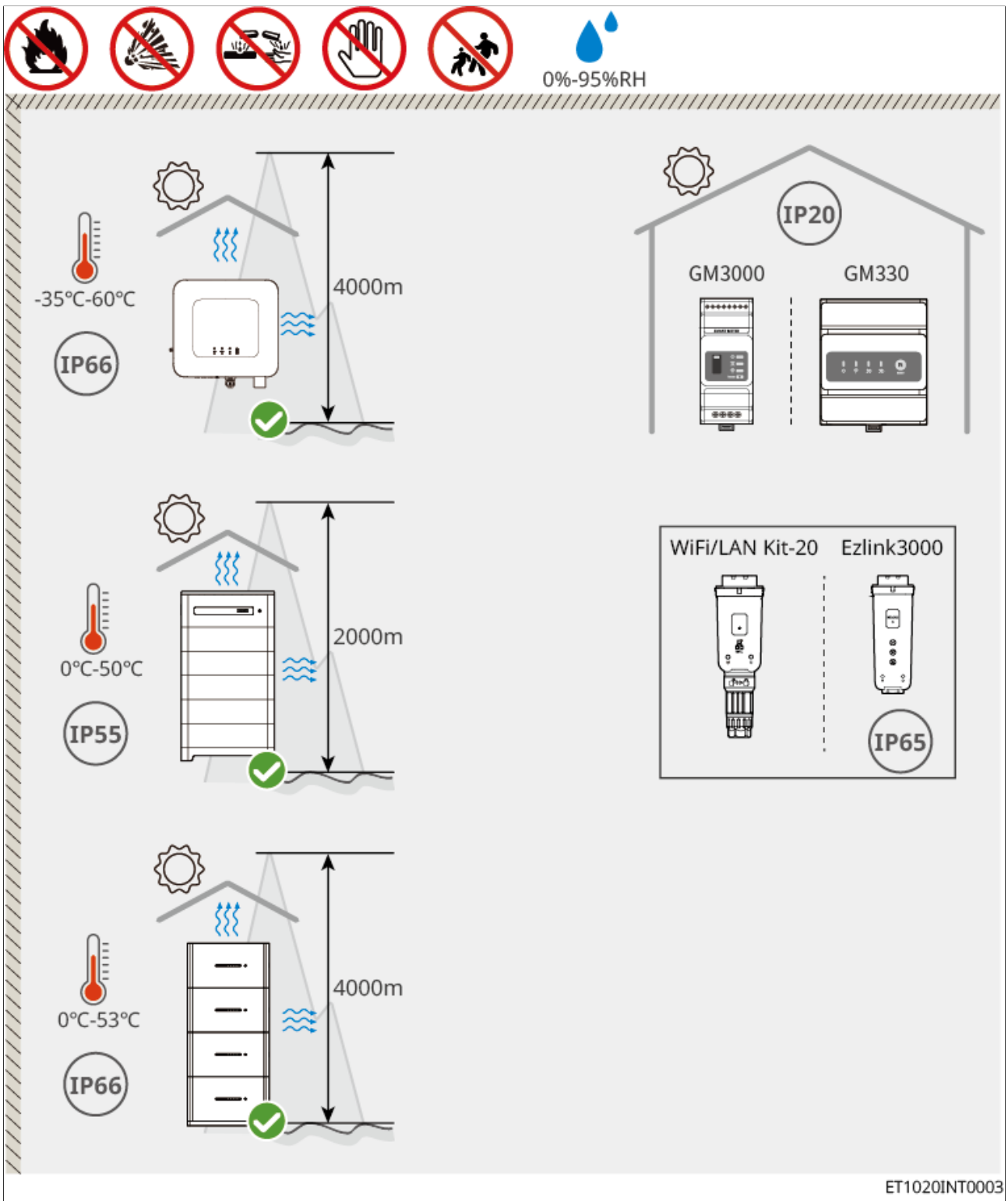

Figure5 Installation

4.2.2 Installation Space Requirements

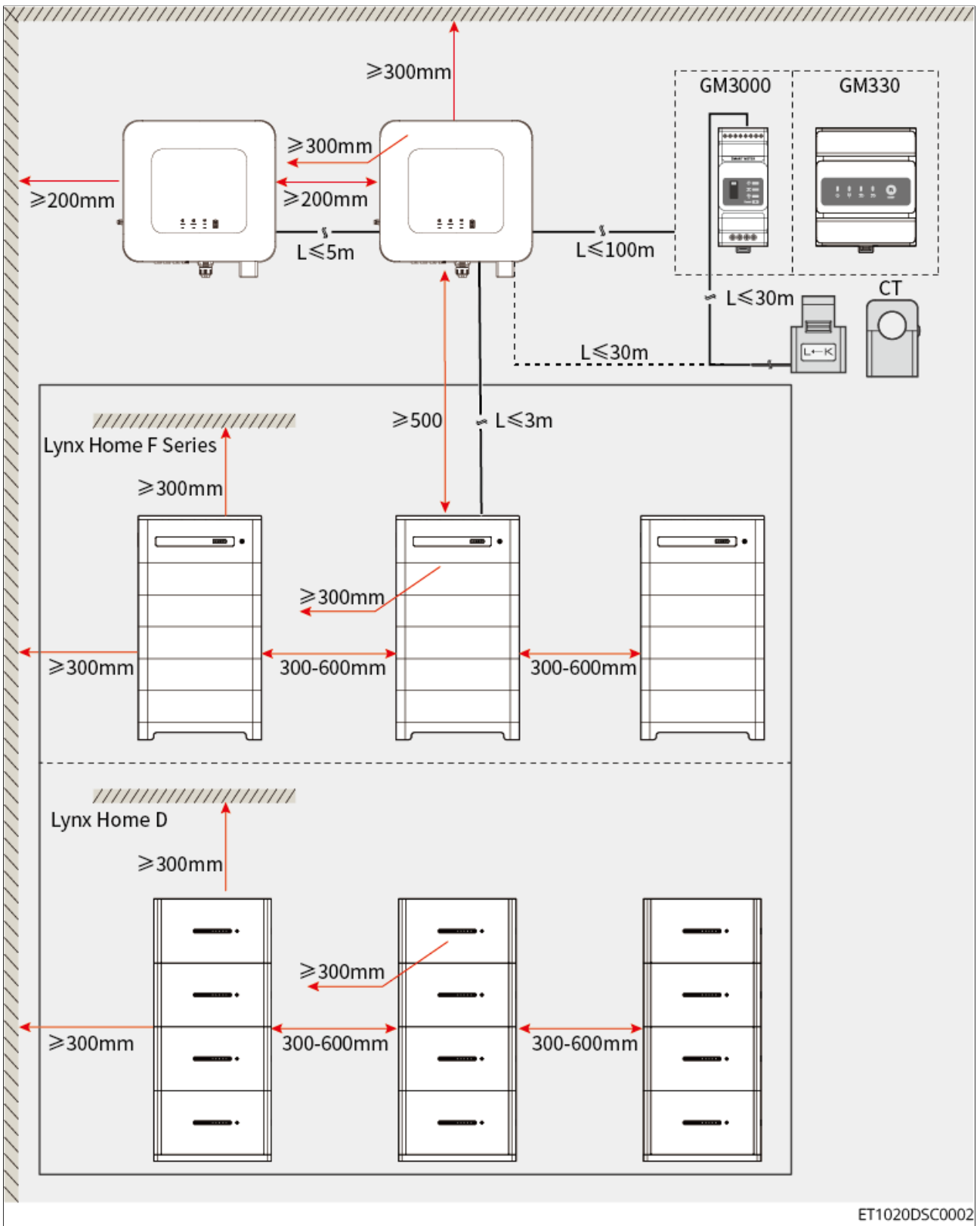



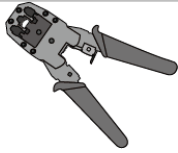
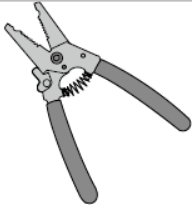
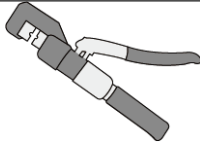
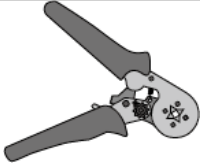

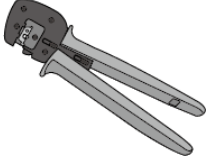
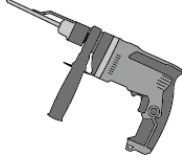
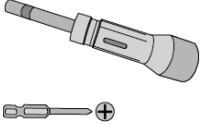

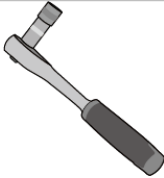

Figure6 Installation Space Requirements





4.2.3 Tool Requirements

NOTICE

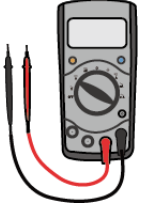
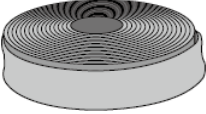

During installation, it is recommended to use the following installation tools. If necessary, other auxiliary tools can be used on-site.

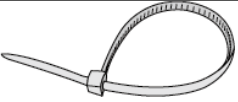
Installation Tools

Tool Type	Description	Tool Type	Description
	diagonal plier		RJ45 connector crimping tool
	wire stripper		YQK-70 hydraulic pliers
	VXC9 hydraulic pliers		open-end wrench
	PV terminal crimping tool PV-CZM-61100		hammer drill (drill bit Φ8mm)
	torque wrench M5, M6, M8		rubber hammer
	socket wrench		marker pen

	multimeter range ≤1100V		heat shrink tubing
	heat gun		cable tie
	vacuum cleaner		Level bar

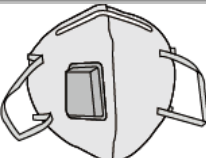
personal protective equipment

Tool Type	Description	Tool Type	Description
	Insulated gloves, protective gloves		Dust mask
	goggle		Safety shoes

4.3 Equipment Handling

 CAUTION

- During operations such as transportation, turnover, and installation, it must comply with the laws, regulations, and relevant standard requirements of the country or region where it is located.
- Before installation, the equipment needs to be moved to the installation site. To avoid personal injury or equipment damage during the moving process, please note the following:
 1. Please allocate personnel according to the weight of the equipment to prevent the equipment from exceeding the weight range that can be manually carried, causing injury to personnel.
 2. Please wear safety gloves to avoid injury.
 3. Please ensure that the equipment remains balanced during moving to avoid falling.

4.4 Installing the Inverter

CAUTION

- When drilling holes, ensure the drilling location avoids water pipes, cables, etc. inside the wall to prevent hazards.
- When drilling, please wear safety goggles and a dust mask to avoid inhaling dust into the respiratory tract or getting it into the eyes.
- Ensure the inverter is securely installed to prevent it from falling and injuring personnel.

1. Place the back mounting plate horizontally on the wall and use a marker pen to mark the drilling positions.
2. Use an impact drill to create the holes.
3. Secure the inverter back mounting plate bracket to the wall using expansion screws.
4. Lock the DC switch in the "OFF" position using a DC switch lock, then hang the inverter onto the backplate. (Optional) For Australia only, the DC switch lock is user-supplied; please ensure the lock's aperture meets the requirements.
5. Use screws to secure the backplate and the inverter, ensuring the inverter is firmly installed.

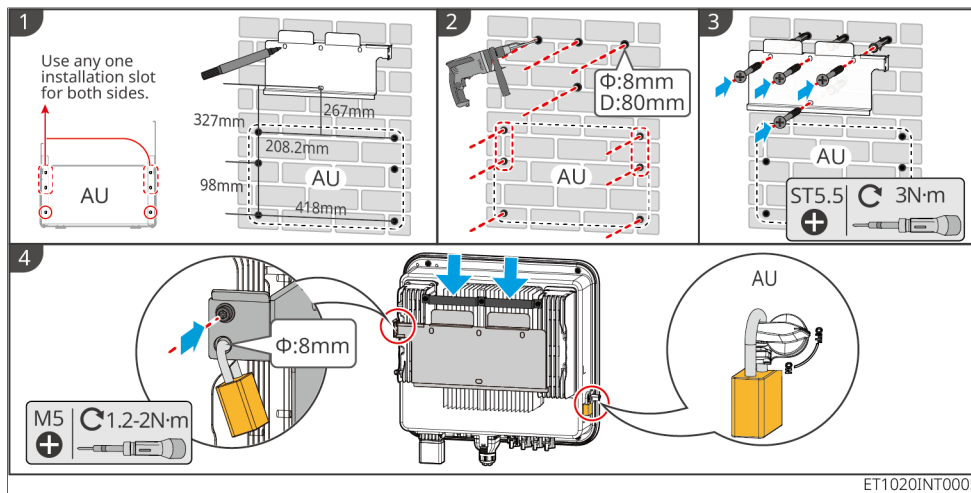

Figure7 Installing the Inverter

Installing the Protective Cover (Australia Only)

1. Assemble the protective cover.
2. Install the front cover panel.
3. Secure the protective cover to the wall.

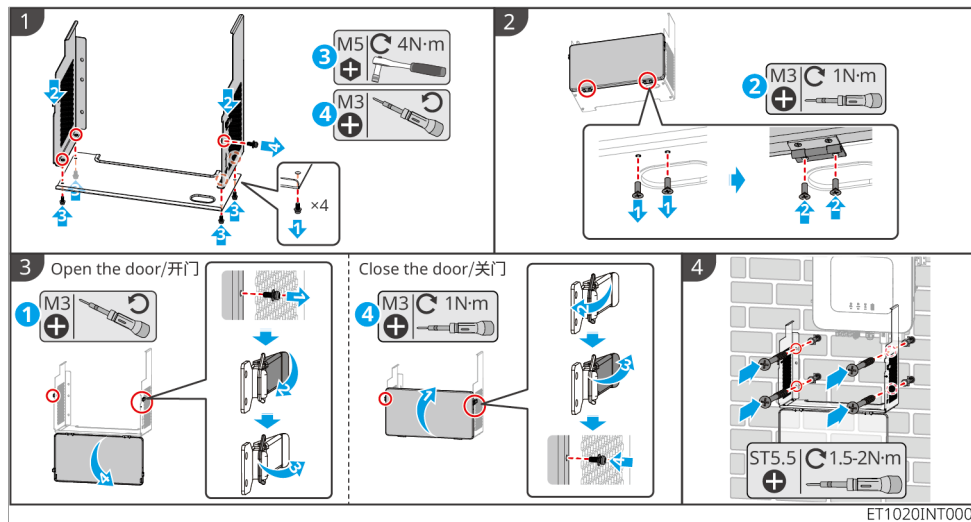

Figure8 Installing the Protective Cover

4.5 Installing the Battery System

4.5.1 Installing the Lynx Home F Series

 **WARNING**

- Ensure the control box is installed above the battery. Do not install the battery above the control box.
- When installing the battery system, ensure it is level and secure. When placing the battery base, battery, or control box, confirm that the holes on the upper and lower layers are aligned; ensure the anti-tipping bracket is vertical and tightly against the ground, wall, or the surface of the battery system.
- When using an impact drill to make holes, use cardboard or other coverings to shield the battery system to prevent foreign objects from entering the equipment and causing damage.
- Before installing the battery system, remove the protective cover from the battery module's wiring port.
- After using a marker to mark the drilling position, lift the control box down to avoid damaging the equipment due to the impact drill being too close to the control box during drilling.

4.5.1.1 Installing Lynx Home F

1. Install the anti-tip bracket onto the base.
2. Place the base against the wall, use a marker to mark the drilling positions, and then remove the base.
3. Use an impact drill to create the holes.
4. Secure the base using expansion screws, ensuring the base is oriented correctly.
5. Remove the protective cover from the battery connection terminals.
6. Install the battery onto the base, ensuring the battery orientation matches the base orientation; and install the remaining battery modules and control box according to the actual selected battery system type.
7. Pre-install the control box anti-tip bracket onto the control box.
8. Place the control box on top of the battery, ensure it is firmly positioned, use a marker to mark the drilling positions, and then remove the control box.
9. Use an impact drill to create the holes.
10. Fix the control box anti-tip bracket to the wall.
11. Secure the anti-tip bracket to the control box.

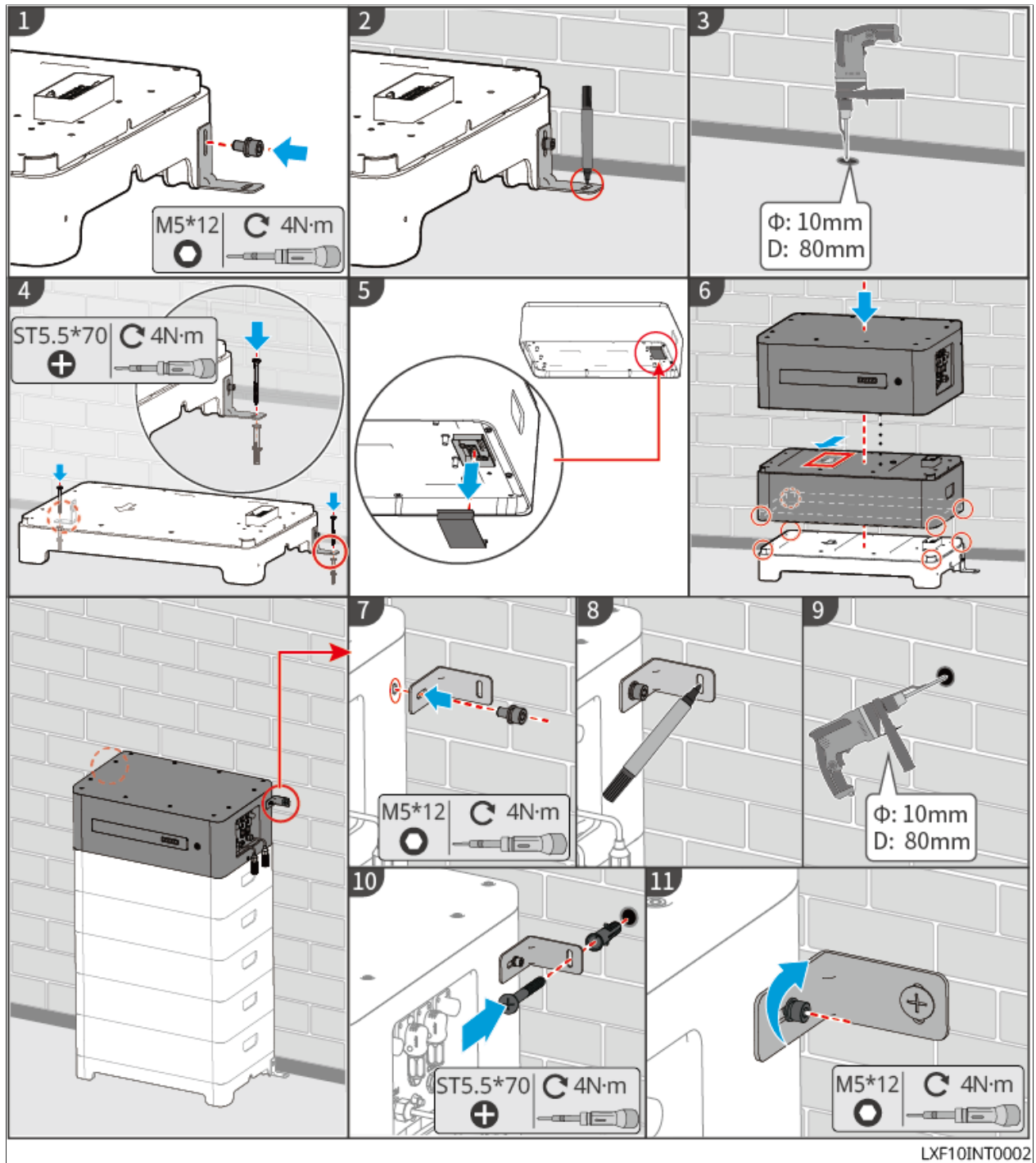

Figure9 Battery Installation

4.5.1.2 Installing Lynx Home F Plus+

1. (Optional) Install the adjustable feet to the battery base.
2. Install the anti-tip bracket to the base.
3. Place the base against the wall, use a marker to mark the drilling positions, and remove the base.
4. Use an impact drill to drill holes.
5. Secure the base with expansion screws, ensuring the base is oriented correctly.
6. Remove the battery terminal cover.
7. Install the battery onto the base, ensuring the battery orientation matches the base; and based on the actual selected battery system type, install the remaining battery modules and control box.
8. Pre-install the control box anti-tip bracket to the control box.
9. Install the control box above the battery, ensure it is firmly placed, use a marker to mark the drilling positions, and remove the control box.
10. Use an impact drill to drill holes.
11. Secure the control box anti-tip bracket to the wall.
12. Secure the anti-tip bracket to the control box.
13. (Optional) After the battery system installation is complete, check if it is installed level and firm; if there is tilting or shaking, adjust the battery system installation status by rotating the adjustable feet.

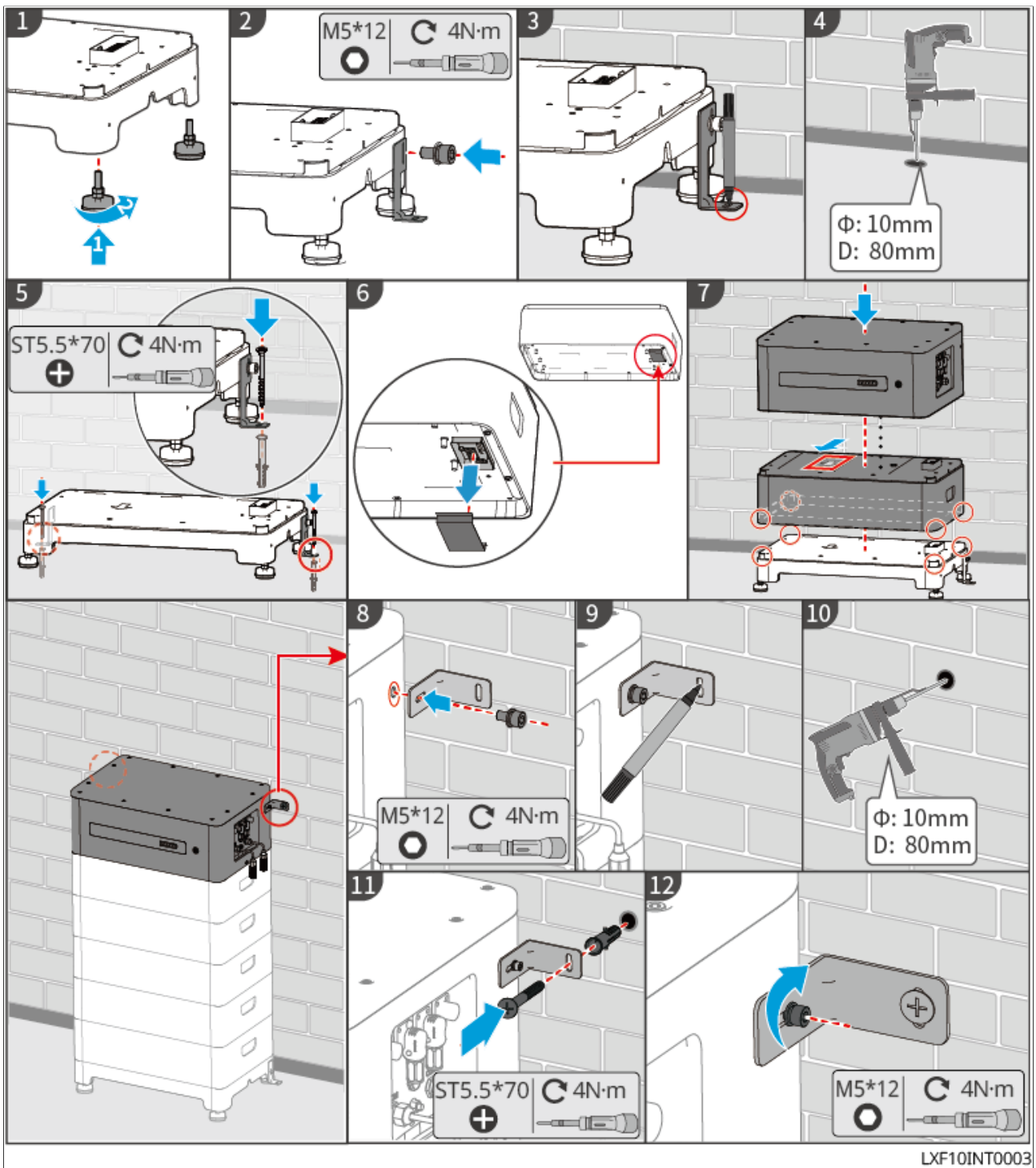

Figure10 Battery Installation

4.5.1.3 Installing Lynx Home F G2

1. (Optional) Install the adjustable feet to the battery base.

2. Install the anti-tip bracket to the base.
3. Place the base against the wall, use a marker to mark the drilling positions, and remove the base.
4. Use an impact drill to drill holes.
5. Secure the base with expansion screws, ensuring the base is oriented correctly.
6. Install the battery to the base, ensuring the battery orientation matches the base orientation; and install the remaining battery modules and control box based on the actual selected battery system type.
7. Install the control box anti-tip bracket.
8. Place the control box above the battery, ensure it is firmly placed, use a marker to mark the drilling positions, and remove the control box.
9. Use an impact drill to drill holes.
10. Tighten the control box anti-tip bracket.
11. Install the anti-tip bracket and junction box.
 - (Optional) Secure the control box anti-tip bracket.
 - (Optional) Install the junction box.
12. (Optional) After the battery system installation is complete, check if it is installed level and secure. If there is tilting or shaking, adjust the battery system installation status by rotating the adjustable feet.

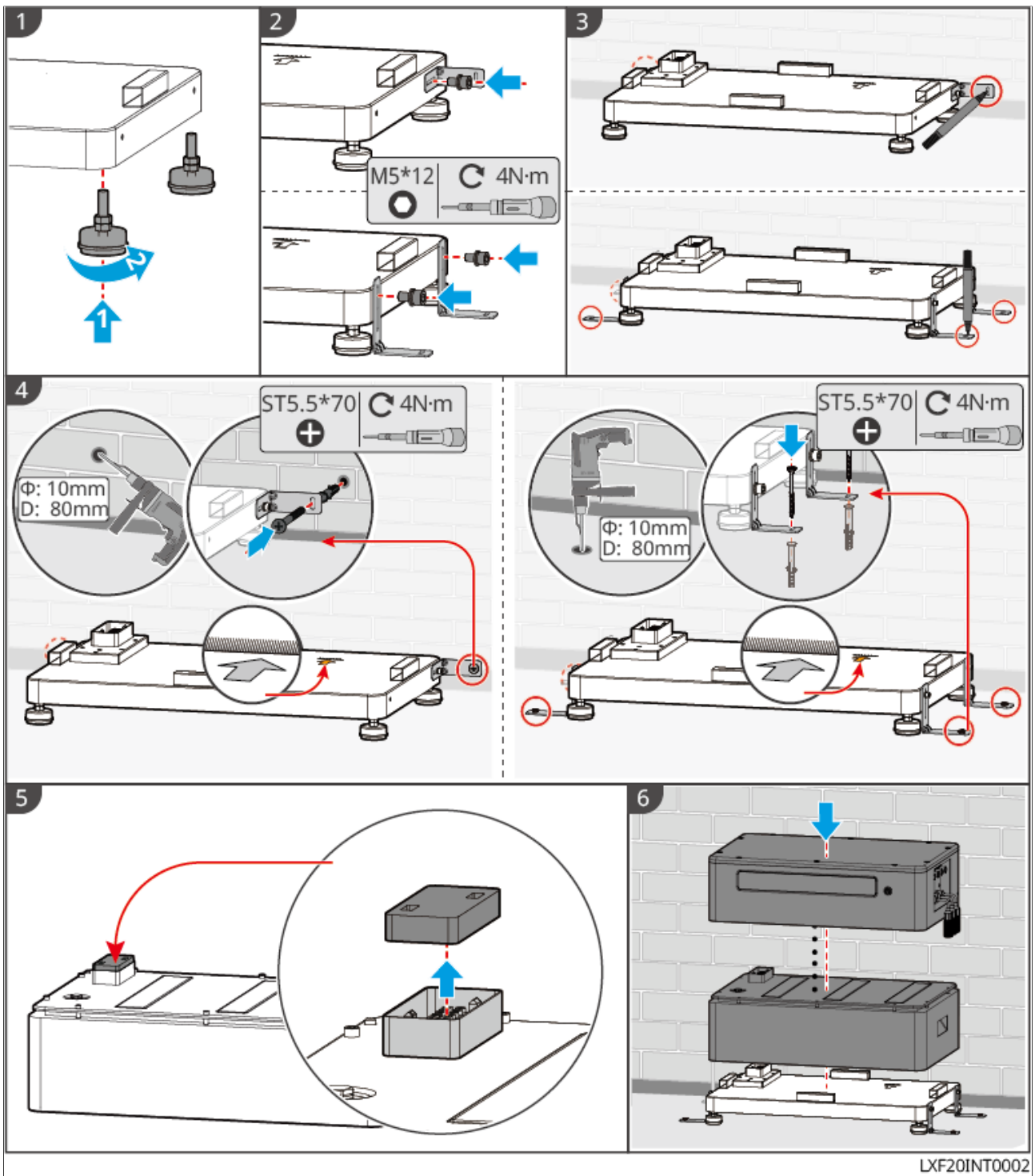

Figure11 Installing the base and battery

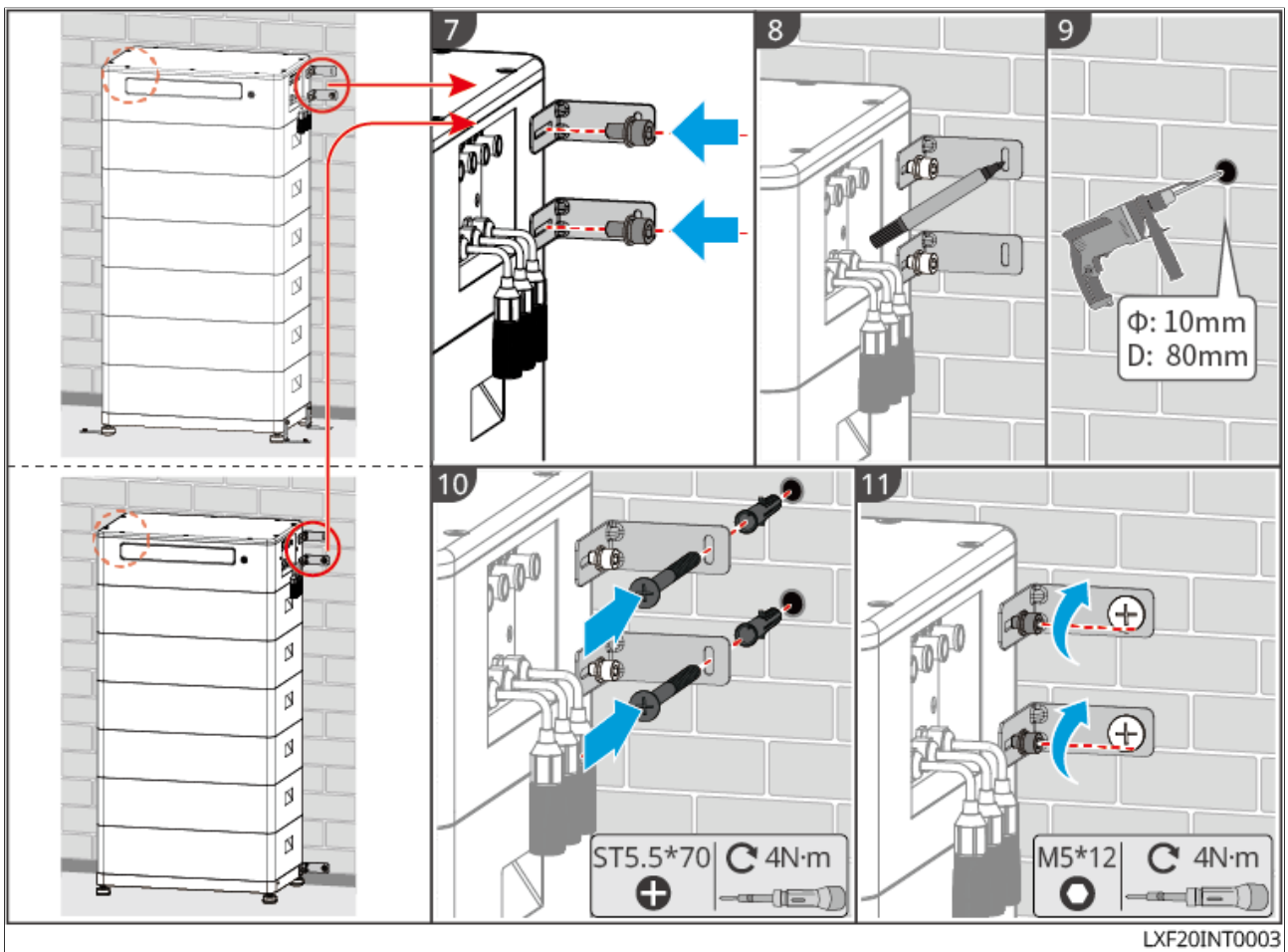

Figure12 Securing the battery system

4.5.2 Installing Lynx Home D

NOTICE

- The battery system must be installed on a base or bracket.
- When stacking batteries, auxiliary tools must be used for installation.
- When a single group of batteries is stacked over 3 pieces, it is recommended to use base installation.
- Please stack the batteries according to the recommended battery stacking method.

Battery Stacking Method		
Total Number of Batteries (units)	First Stack (units)	Second Stack (units)
8	4	4
7	4	3
6	3	3
5	3	2
4	2	2
3	3	-
2	2	-
1	1	-

Installing the Bracket (Optional)

1. Place the bracket flush against the wall. Ensure the bracket is securely placed, and use a level to measure if the bracket is horizontal.
2. After adjusting the position and levelness of the bracket, use a marker to mark the drilling positions. Once marked, remove the bracket.
3. Drill holes and install expansion screws.
 - a. Use an impact drill to drill holes.
 - b. Clean the holes.
 - c. Use a rubber hammer to install the expansion screws into the holes.
 - d. Use a hex key to tighten the nuts clockwise to expand the screws.
 - e. Rotate the nuts counterclockwise to remove them.
4. Use a hex key to secure the wall mount to the wall.

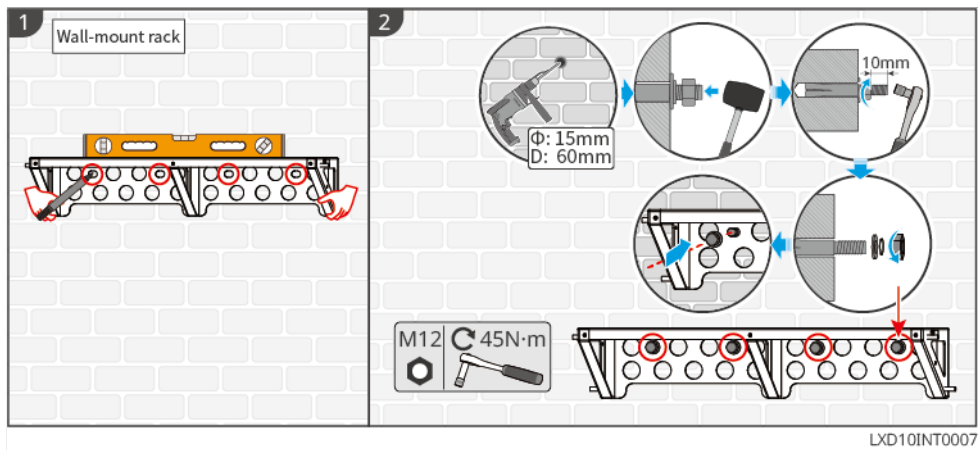

Figure13 Installing the Bracket

Installing the Base (Optional)

NOTICE

Check if there are adjustable feet in the accessory pack. If not and you need to use them, please contact the dealer or after-sales service to obtain them.

1. Install the adjustable feet to the bottom of the base.
2. Place the base 15-20mm away from the wall, keep it parallel to the wall, and ensure the ground is level.
3. When using the base to install the battery, ensure that the left side of the battery aligns with the limit block of the base.

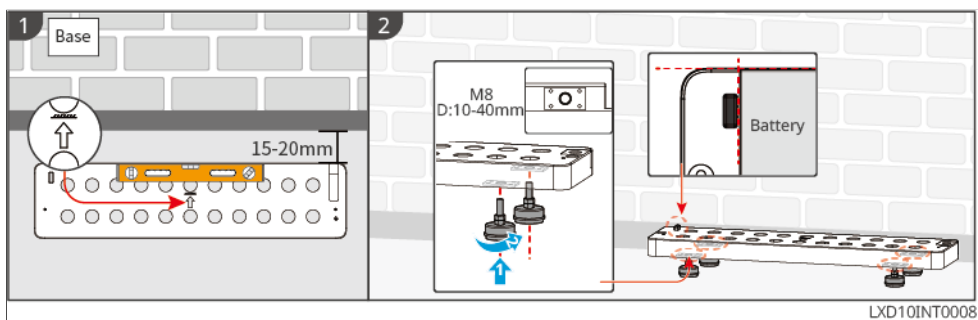

Figure14 Installing the Base

Installing the Battery System

NOTICE

- For floor installation, two base and battery fixing brackets are included in the package. To prevent the battery from loosening or shifting, install one fixing bracket on the side of the battery positioning block, and keep the other as a spare.
- For wall-mounted installation, to prevent the battery from loosening or shifting, use the fixing brackets included in the package to secure both the battery and the wall mount brackets on both sides.

1. Pre-tighten and secure the anti-tipping bracket to the battery.
2. Place the battery on the installed bracket or base. Make the anti-tipping bracket flush against the wall, mark the positions for drilling, then remove the battery; or use a level to mark the drilling positions.
3. Install expansion screws and secure the battery.
 - a. Use an impact drill to drill holes.
 - b. Clean the holes.
 - c. Use a rubber hammer to install the expansion screws into the holes.
 - d. Use a hex key to tighten the nuts clockwise to expand the screws.
 - e. Rotate the nuts counterclockwise to remove them.
 - f. Reinstall the battery on the base or bracket, and adjust the battery position so that it is 15-20mm away from the wall.
 - g. Use a hex key to secure the battery to the wall, and use a torque screwdriver to tighten the anti-tipping bracket to the battery.
4. Install and tighten the fixing brackets between batteries.

If installing multiple batteries, repeat steps 1 to 4 to complete the installation of all batteries. Do not stack more than 4 batteries in a single group.
5. Install and tighten the fixing brackets between the battery and the base or bracket.

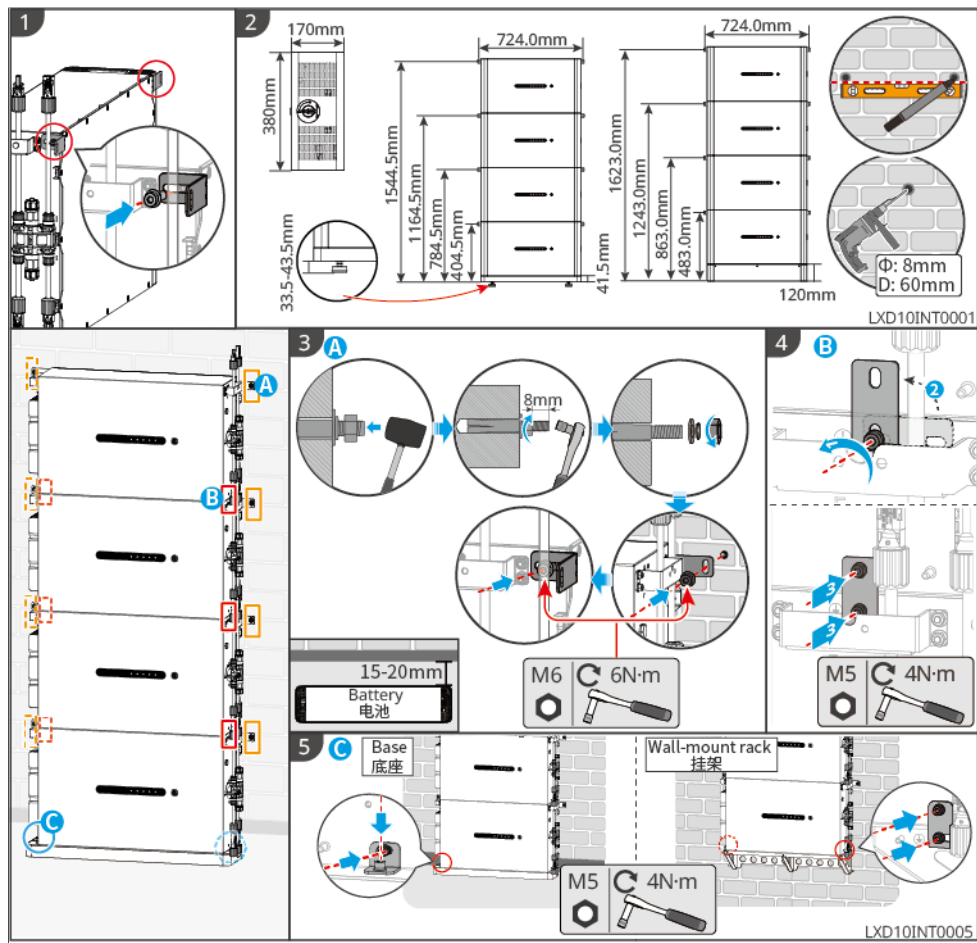

Figure15 Installing the Battery System

4.6 Installing the Smart Meter

⚠️ WARNING

In areas with lightning risk, if the meter cable length exceeds 10m and the cabling is not done using grounded metal conduit, it is recommended to install external lightning protection devices.

GM3000

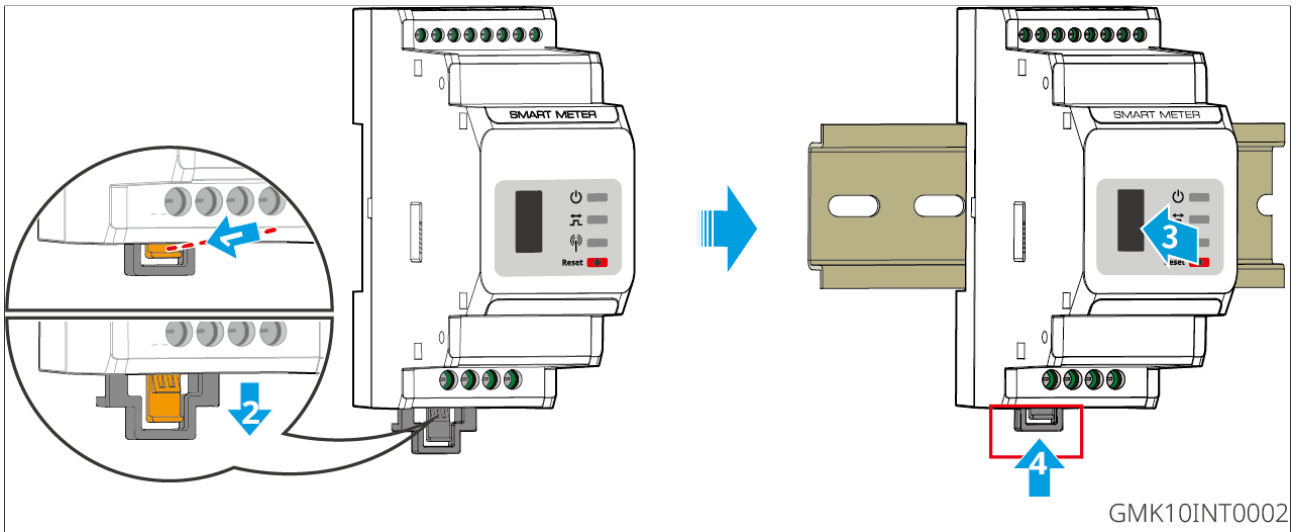

Figure16 Installing GM3000

GM330

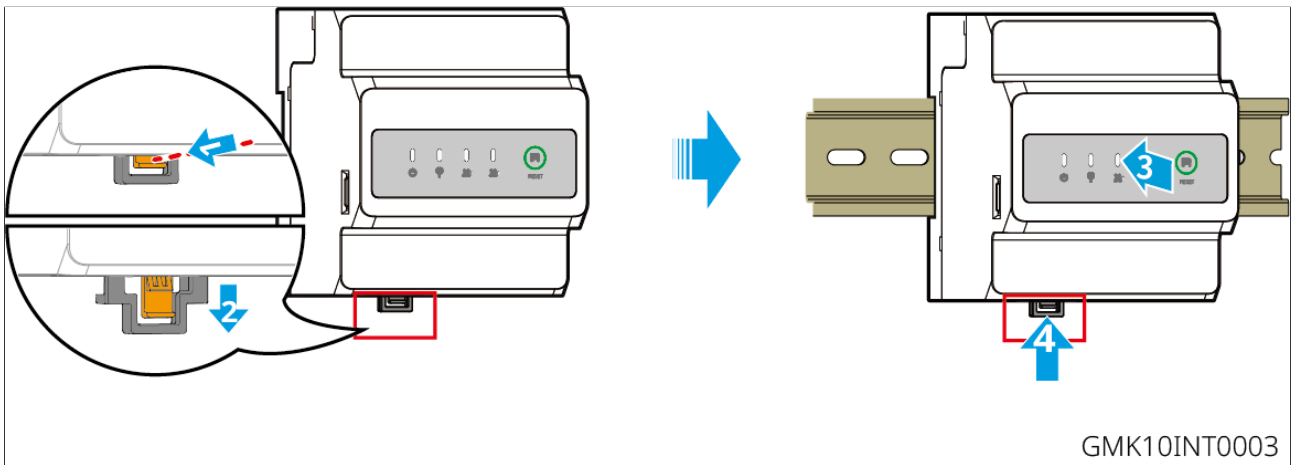

Figure17 Installing GM330

5 System Wirings

DANGER

- All operations during electrical connections, as well as the specifications of cables and components used, must comply with local laws and regulations.
- Before performing any electrical connections, disconnect the DC switch and AC output switch of the equipment to ensure it is powered off. Live working is strictly prohibited, otherwise electric shock or other hazards may occur.
- Cables of the same type should be bundled together and routed separately from different types of cables. Intertwining or crossing different cable types is prohibited.
- If the cable is subjected to excessive tension, poor connections may result. When connecting, leave a certain length of slack in the cable before connecting it to the inverter terminal.
- When crimping terminals, ensure the conductor part of the cable is in full contact with the terminal. Do not crimp the cable insulation together with the terminal, as this may cause equipment malfunction, or after operation, lead to issues such as heating due to unreliable connections, potentially damaging the equipment's terminal block.

NOTICE

- When performing electrical connections, wear personal protective equipment such as safety shoes, protective gloves, and insulated gloves as required.
- Only qualified professionals are permitted to perform electrical connection operations.
- The cable colors shown in the diagrams in this document are for reference only. Specific cable specifications must comply with local regulatory requirements.

5.1 System Wiring Electrical Block Diagram

NOTICE

- Depending on regional regulatory requirements, the wiring methods for the N and PE lines of the Inverter's ON-GRID and BACK-UP ports differ. Please follow local regulations.
- The Inverter has a built-in energy meter and can be directly connected to a CT for use.
- Accuracy may decrease when the connection length between the CT and the Inverter exceeds 25m. For high-precision requirements, an external smart meter can be used.
- The Inverter's ON-GRID AC port has a built-in relay. When the Inverter is in off-grid mode, the built-in ON-GRID relay is open; when the Inverter is in grid-tied operation mode, the built-in ON-GRID relay is closed.
- When the Inverter is powered on, the BACK-UP AC port is live. If maintenance is required on the BACK-UP load, please power down the Inverter to avoid the risk of electric shock.

The N and PE wires are connected together in the distribution box

NOTICE

- To maintain neutral integrity, the neutral wires on the grid side and the off-grid side must be connected together, otherwise the off-grid function cannot operate normally.
- The diagram below is a schematic for grid systems in regions such as Australia and New Zealand:

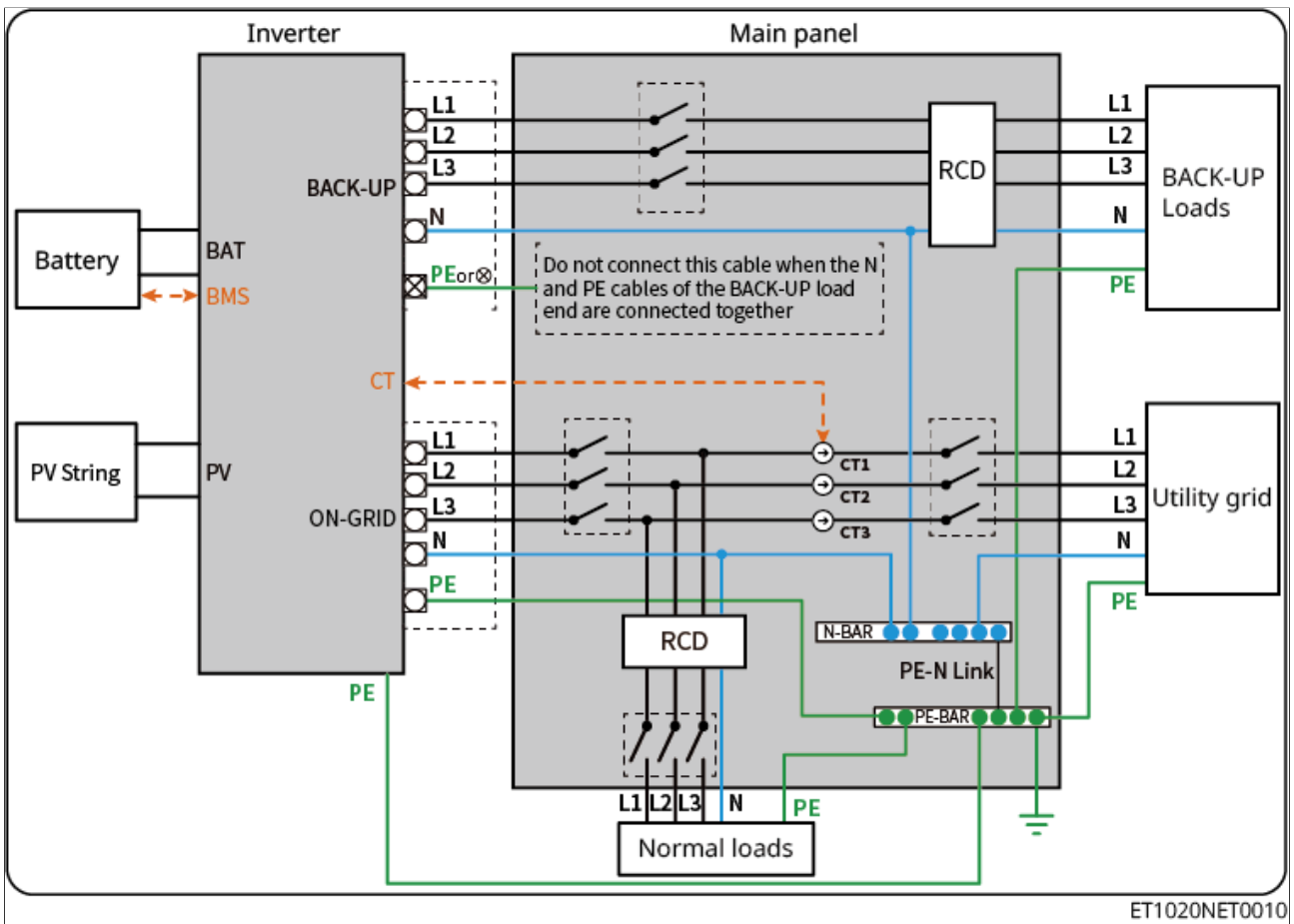

Figure18 Regions such as Australia and New Zealand

N and PE wires are wired separately in the distribution box

NOTICE

- Please ensure that the protective ground wire of BACK-UP is correctly and securely connected; otherwise, the BACK-UP function may malfunction when a grid fault occurs.
- For regions other than Australia, New Zealand, etc., the following wiring method applies:

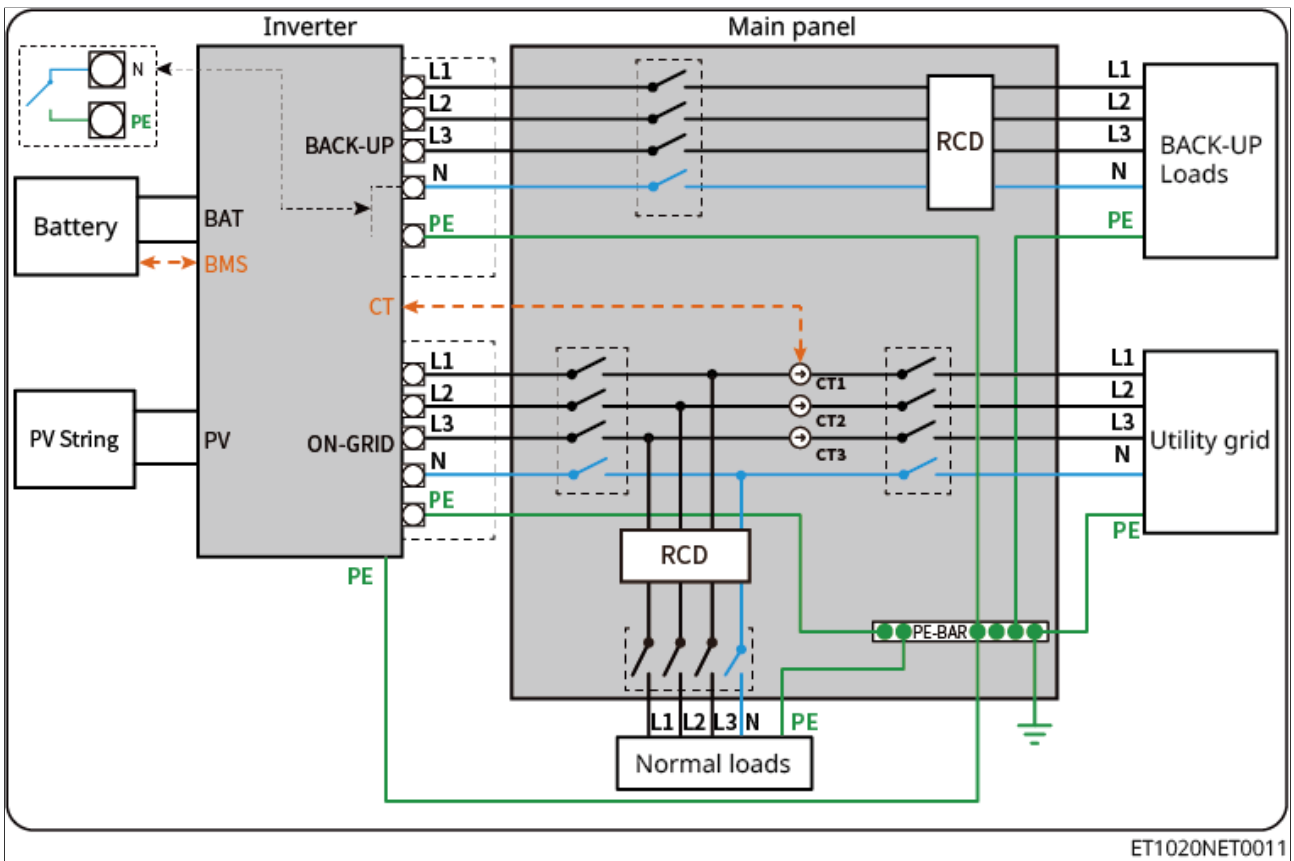

Figure19 Regions other than Australia, New Zealand, etc.

5.2 Detailed System Wiring Diagram

When all loads in the PV system cannot consume the electricity generated by the system, the surplus power will be fed into the grid. In this case, a smart meter or CT monitoring system can be used to monitor the system's power generation and control the amount of power fed into the grid.

- Connecting a smart meter enables output power limiting and load monitoring functions.
- After connecting the smart meter, please enable the "Export power limit" function via the SolarGo App.

The Detailed System Wiring Diagram only illustrates the wiring with some model devices. Please refer to the corresponding wiring guide chapter for the actual devices used when making connections.

NOTICE

- Can be optionally equipped with GM330 or GM3000 meter. If needed, please contact GoodWe to purchase.
- In coupling scenarios, if you need to achieve grid-tied inverter power generation monitoring and load monitoring functions, a dual-meter network is required.
 - Meter 1 or the built-in meter is used to monitor the system's grid-tied power.
 - Meter 2 is used to monitor the grid-tied inverter's power generation.
 - By integrating the data from Meter 1 and Meter 2, the monitoring platform can achieve real-time monitoring of load power consumption.
- If the grid-tied inverter needs output power limitation, please connect a meter or CT device separately.

Dual Meter Configuration Scenarios

Meter 1 (Grid Side)	Meter 2 (Grid-tie Inverter AC Side)
Built-in meter	GM3000
Built-in meter	GM330
GM3000	GM3000
GM3000	GM330
GM330	GM330
GM330	GM3000

Wiring Diagram with Protective Cover (Optional)

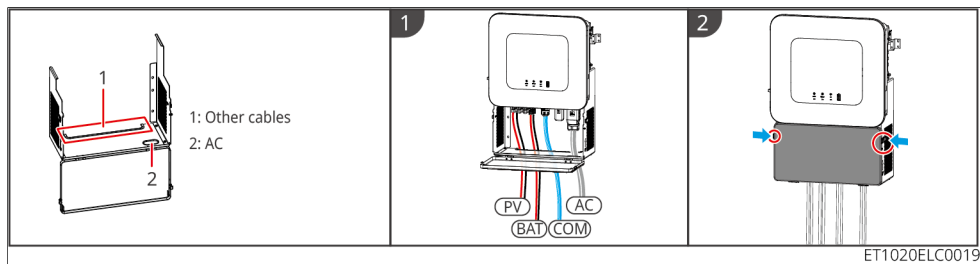

5.2.1 Detailed System Wiring Diagram for Single Inverter

Scenario Using Built-in Meter

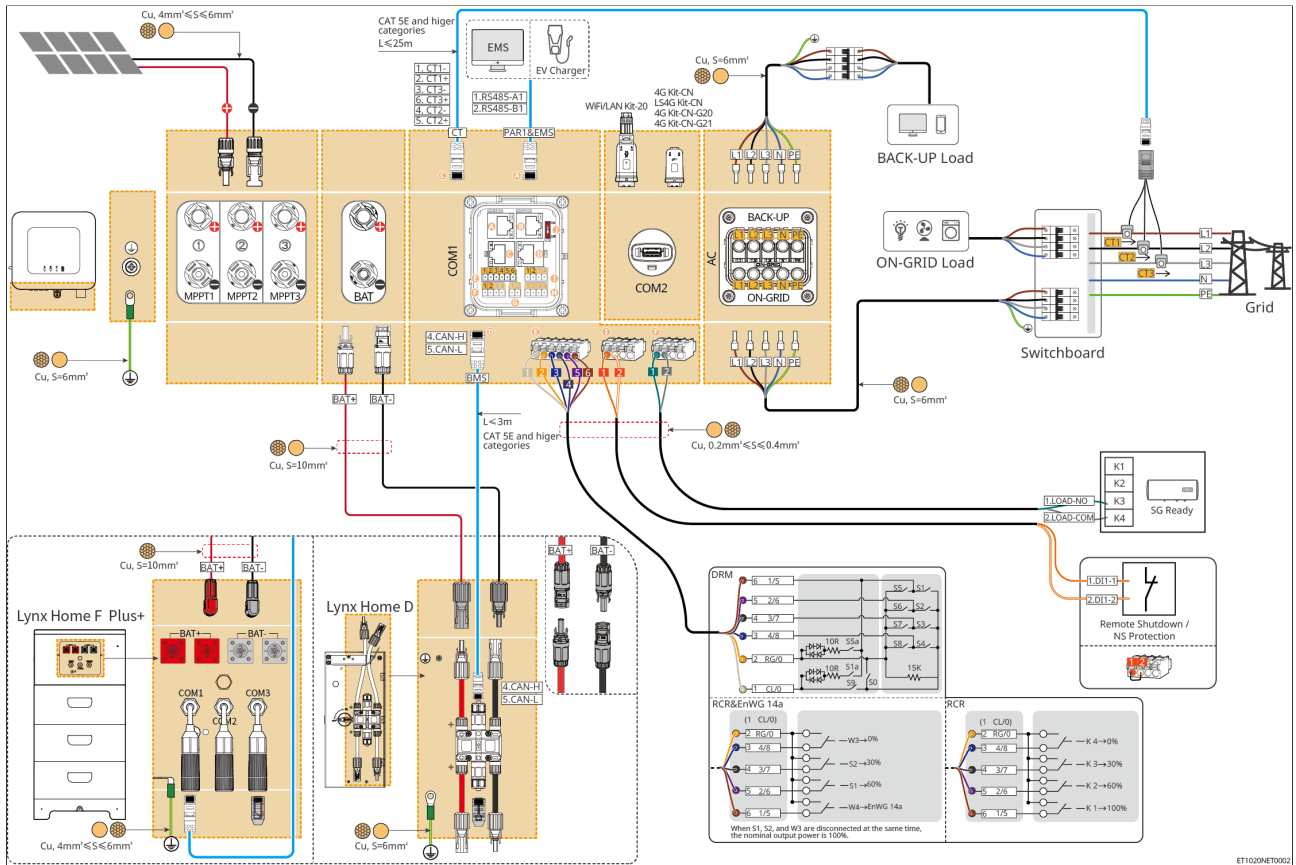

Figure20 Scenario Using Built-in Meter

Scenario with GM3000

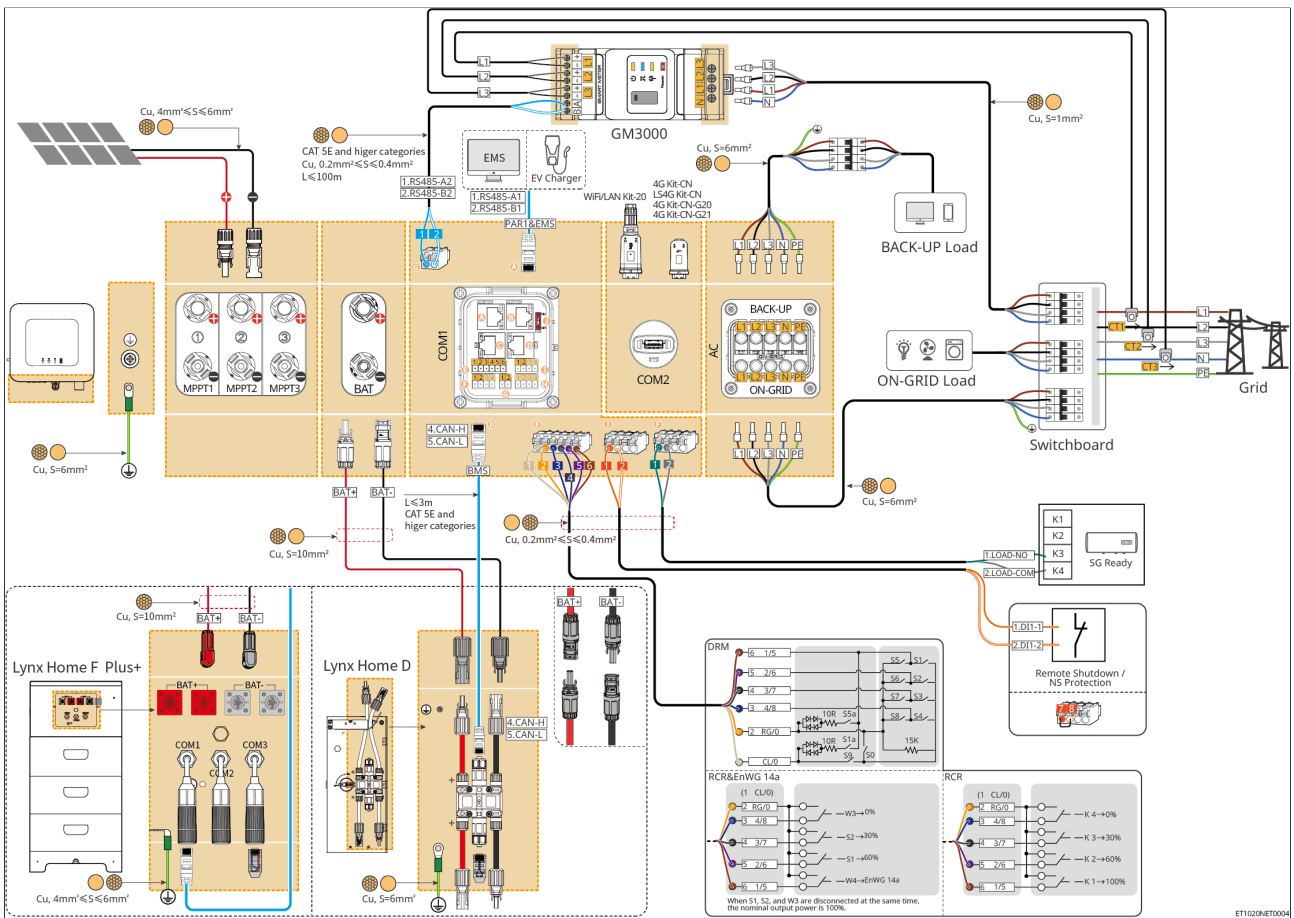

Figure21 Scenario with GM3000

Scenario with GM330

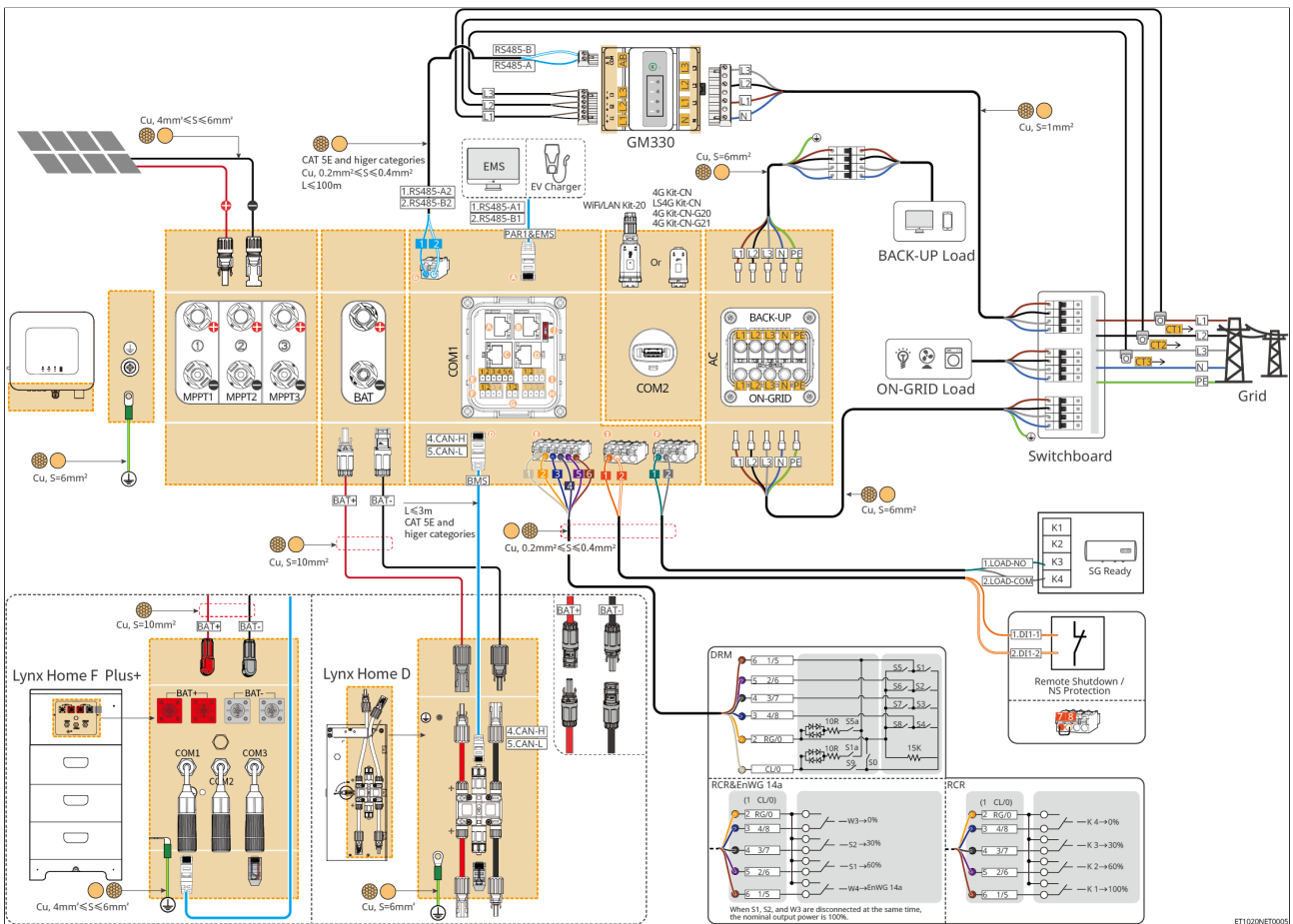

Figure22 Scenario with GM330

Networking Solution for Load Monitoring in Coupled Scenarios and Power Generation Monitoring of Grid-tied Inverters

Networking with Built-in Meter +GM330

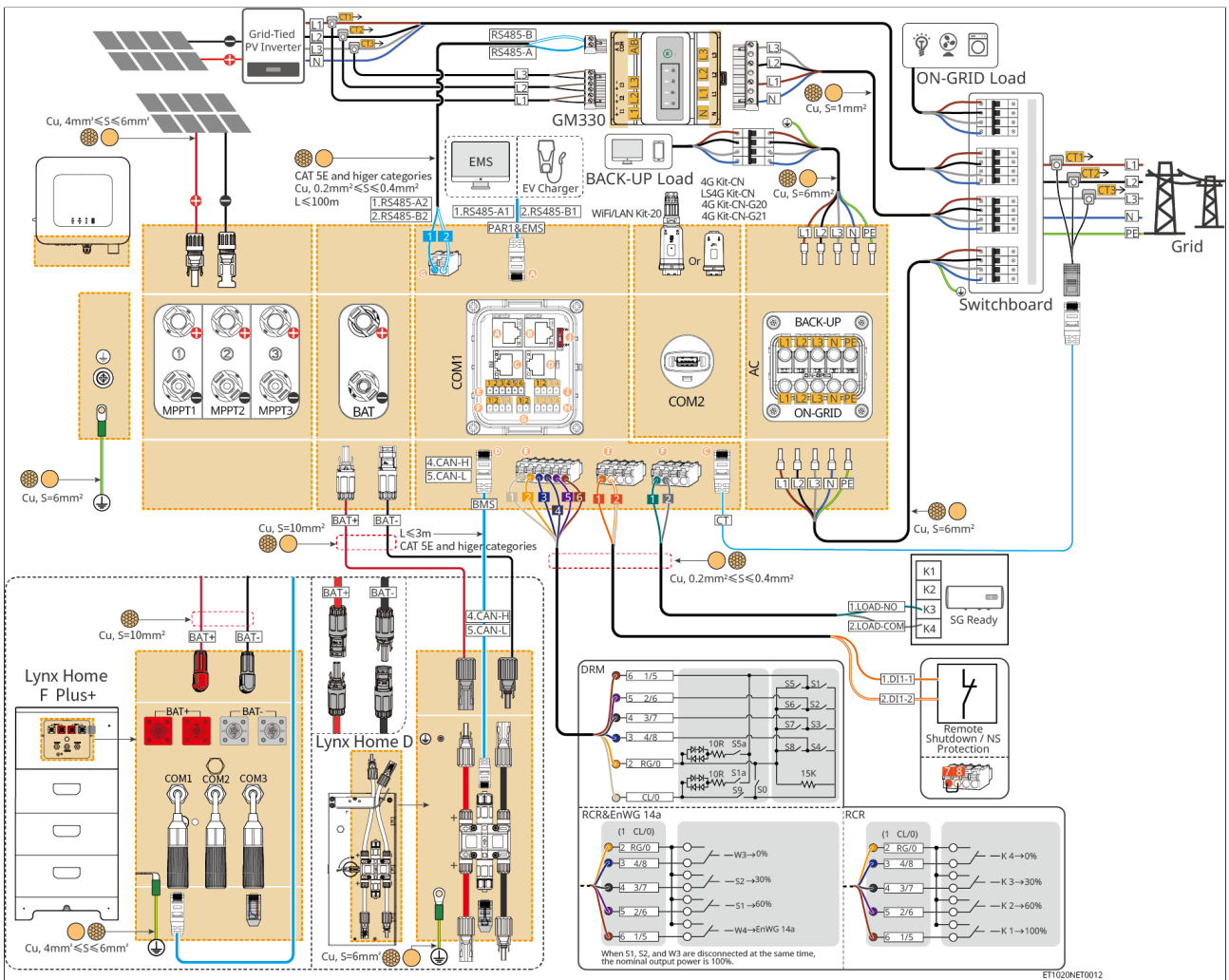

Figure23 Networking with Built-in Meter +GM330

WithGM330+GM330Networking

If the grid-tied inverter requires output power limitation, please connect a meter or CT device separately.

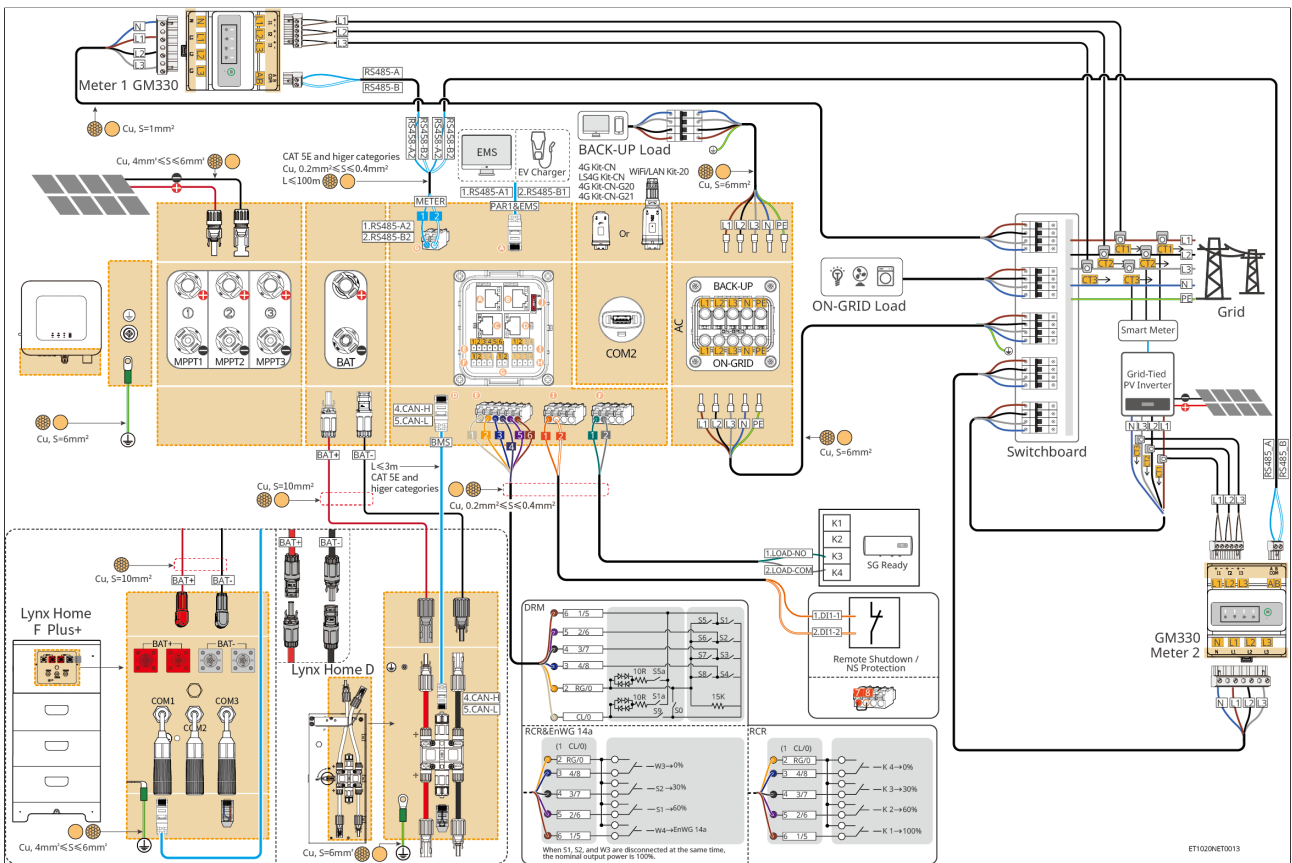

Figure 24 Networking with GM330+GM330

5.2.2 Detailed System Wiring Diagram for Parallel System

- In a parallel scenario, the inverter connected to the Ezlink3000 smart communication stick and the meter is the master inverter, while others are slave inverters. Do not connect the smart communication stick to slave inverters in the system.
- If devices such as DRED devices, RCR devices, remote shutdown devices, NS Protection, SG Ready heat pumps, etc., need to be connected in the system, please connect them to the master inverter.
- The following diagrams focus on wiring related to parallel systems. For other port wiring requirements, please refer to the single-unit system.

Scenario with Built-in Meter

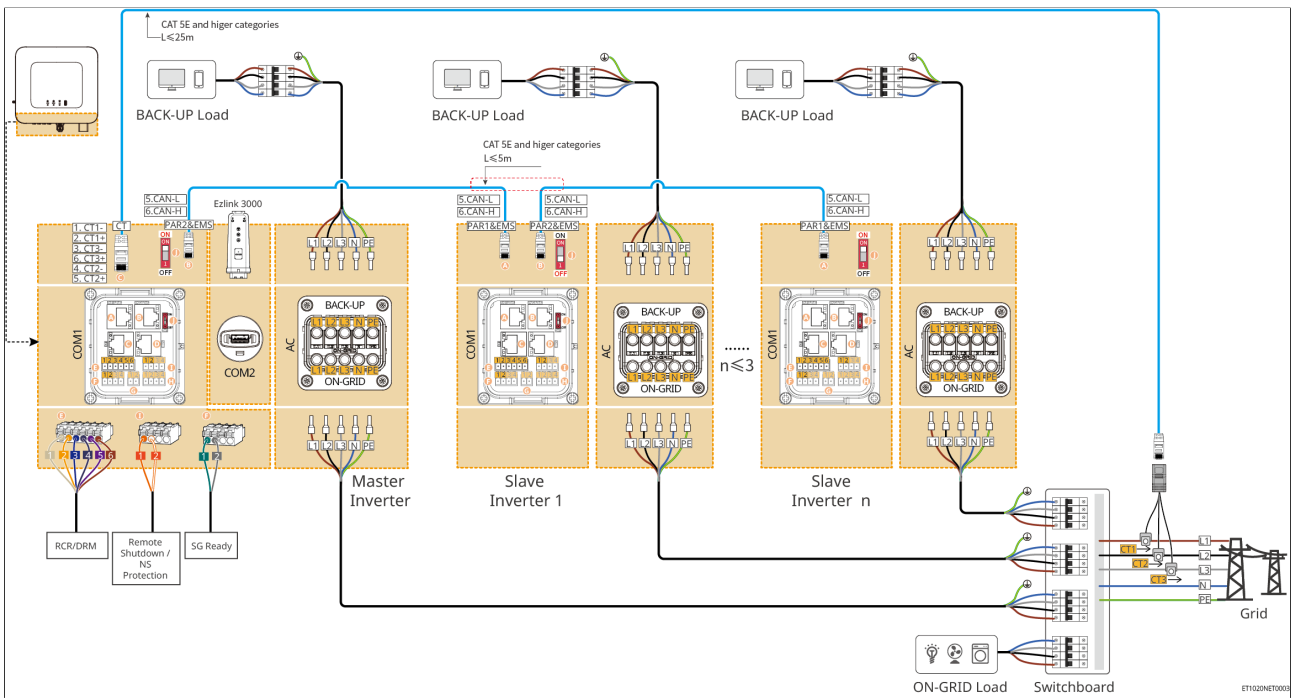

Figure25 Scenario with Built-in Meter

with GM3000 Scenario

The wiring method for inverter parallel systems with GM3000 is similar to that with GM330, only the meter connection method is different. Please refer to the **with GM3000 Scenario** in the single-unit system and the **with GM330 Scenario** in the parallel system for wiring.

with GM330 Scenario

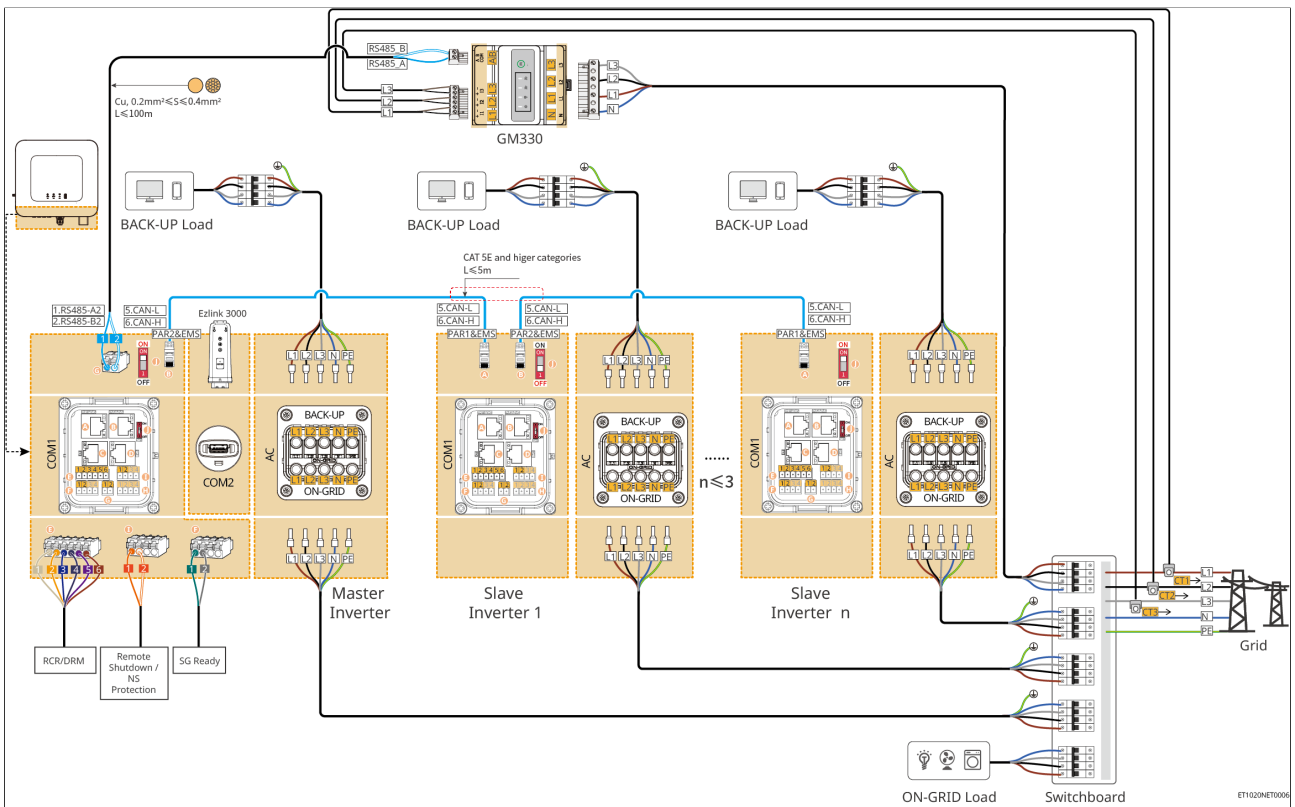

Figure26 Scenario with GM330

Networking Solution for Load Monitoring in Coupling Scenario and Grid-Connected Generator Power Monitoring

GMK330 meter + GMK330 meter

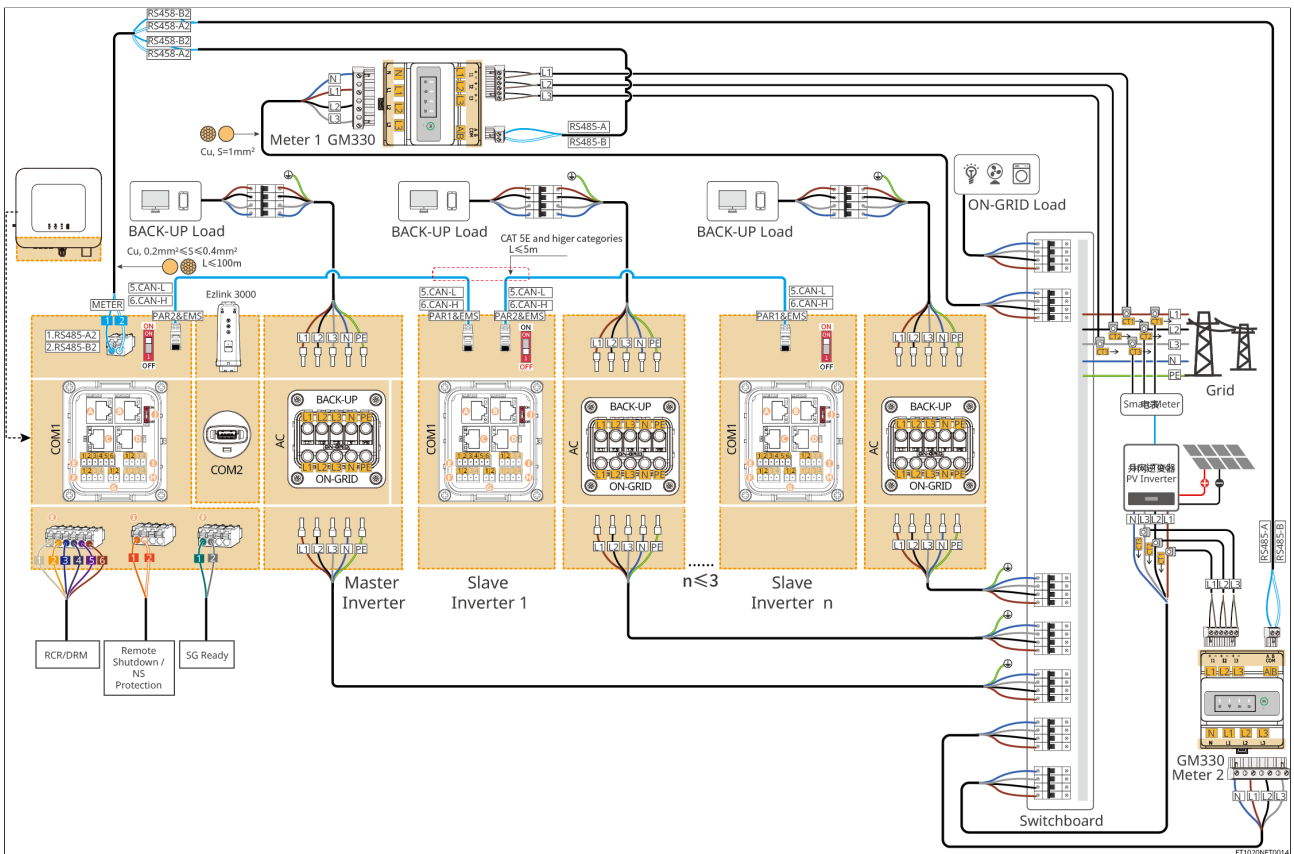

Figure27 GMK330 meter + GMK330 meter

5.3 Preparing Materials



WARNING

- Do not connect loads between the inverter and the AC switch directly connected to the inverter.
- Each inverter must be equipped with an AC output circuit breaker. Multiple inverters must not share a single AC circuit breaker.
- To ensure the inverter can be safely disconnected from the grid in case of an abnormality, please install an AC circuit breaker on the AC side of the inverter. Select a suitable AC circuit breaker according to local regulations.
- When the inverter is powered on, the BACK-UP AC ports are live. If maintenance is required on the BACK-UP loads, power down the inverter first; otherwise, electric shock may occur.

5.3.1 Preparing Breakers

No.	breaker	Recommended Specifications	Acquisition Method	Remarks
1	ON-GRID breaker	<p>When the BACK-UP port is loaded, the Nominal Voltage $\geq 230V$, and the Rated Current requirements are as follows:</p> <ul style="list-style-type: none"> • GW6000-ET-20: Rated Current $\geq 20A$ • GW8000-ET-20: Rated Current $\geq 25A$ • GW9900-ET-20, GW10K-ET-20, GW12K-ET-20, and GW15K-ET-20: Rated Current $\geq 32A$ <hr/> <p>When the BACK-UP port is not loaded, the Nominal Voltage $\geq 230V$, and the Rated Current requirements are as follows:</p> <ul style="list-style-type: none"> • GW6000-ET-20, GW8000-ET-20: Rated Current $\geq 16A$ • GW9900-ET-20, GW10K-ET-20: Rated Current $\geq 20A$ • GW12K-ET-20: Rated Current $\geq 25A$ • GW15K-ET-20: Rated Current $\geq 32A$ 	Self-provided	If the inverter's BACK-UP port is not used, select an appropriate breaker based on the maximum AC output current.

No.	breaker	Recommended Specifications	Acquisition Method	Remarks
2	BACK-UP breaker	<p>Nominal Voltage $\geq 230V$, Rated Current requirements are as follows:</p> <ul style="list-style-type: none"> • GW6000-ET-20: Rated Current $\geq 20A$ • GW8000-ET-20: Rated Current $\geq 25A$ • Others: Rated Current $\geq 32A$, Nominal Voltage $\geq 230V$ AC 	Self-provided	-
3	Battery Switch	<p>Select according to local laws and regulations</p> <ul style="list-style-type: none"> • 2P DC Switch • GW6000-ET-20, GW8000-ET-20: Rated Current $\geq 40A$, Nominal Voltage $\geq 720VDC$ • Others: Rated Current $\geq 50A$, Nominal Voltage $\geq 720V$ DC 	Self-provided	-
4	RCD	<p>Select according to local laws and regulations</p> <ul style="list-style-type: none"> • Type A • ON-GRID side: 300mA • BACK-UP side: 30mA 	Self-provided	-
5	Meter Switch	<ul style="list-style-type: none"> • Nominal Voltage: 380V/400V • Rated Current: 0.5A 	Self-provided	-

5.3.2 Preparing Cables

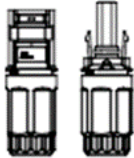
No.	Cable	Recommended Specifications	Acquisition Method
1	Inverter Protective Grounding Cable	<ul style="list-style-type: none"> • Single-core outdoor copper cable • Conductor cross-sectional area: $S=6\text{mm}^2$ 	Self-provided
2	Battery Protective Grounding Cable	<ul style="list-style-type: none"> • Single-core outdoor copper cable • Conductor cross-sectional area: 6mm^2 	Self-provided
3	PV DC Cable	<ul style="list-style-type: none"> • Industry-standard outdoor PV cable • Conductor cross-sectional area: $4\text{mm}^2\text{-}6\text{mm}^2$ • Cable outer diameter: 5.9mm-8.8mm 	Self-provided
4	Battery DC Cable	<p data-bbox="608 1093 842 1128">Terminal Type I</p>  <ul style="list-style-type: none"> • Single-core outdoor copper cable • Conductor cross-sectional area: 10mm^2 • Cable outer diameter: 6.0mm-9.5mm 	Self-provided or purchased from distributor

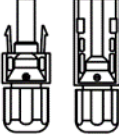
No.	Cable	Recommended Specifications	Acquisition Method
		Terminal Type II  <ul style="list-style-type: none"> • Single-core outdoor copper cable • Conductor cross-sectional area: 10mm² • Cable outer diameter: 5mm-8.5mm 	
5	AC Cable	<ul style="list-style-type: none"> • Multi-core outdoor copper cable • Conductor cross-sectional area: 6mm² • Cable outer diameter: 18mm 	Self-provided
6	Smart Meter Power Cable	Outdoor copper cable Conductor cross-sectional area: 1mm ²	Self-provided
7	Battery BMS Communication cable	Custom communication cable, default length is 3m If self-provided, recommend: CAT 5E or higher specification standard network cable and RJ45 connector	Supplied with the inverter
8	(Optional) Meter RS485 Communication cable	Standard network cable: CAT 5E or higher specification standard network cable and RJ45 connector	RJ45-2PIN terminal adapter cable and standard network cable: Supplied with the package
9	Battery Cluster Communication Cable	CAT 5E or higher specification standard network cable and RJ45 connector	Self-provided

No.	Cable	Recommended Specifications	Acquisition Method
10	Load control and generator control DO communication cable	<ul style="list-style-type: none"> Shielded cable meeting local standards Conductor cross-sectional area: 0.2mm²-0.3mm² Cable outer diameter: 5mm-8mm 	Self-provided
11	Remote Shutdown Communication Cable		
12	RCR/DRED Signal Cable		
13	Inverter Parallel Communication Cable	<ul style="list-style-type: none"> RJ45 connector CAT 5E or higher specification straight-through network cable <p>Recommend length not exceeding 5m</p>	Self-provided
14	EMS Communication Cable/Charging Pile Communication Cable	CAT 5E or higher specification standard network cable and RJ45 connector	Self-provided
15	CT Connection Cable		Self-provided

5.4 Connecting the PE cable

!WARNING

- When installing the equipment, the protective ground wire must be connected first; when removing the equipment, the protective ground wire must be removed last.
- The protective grounding of the chassis cannot substitute for the protective ground wire of the AC output port. During wiring, ensure the protective ground wires at both locations are reliably connected.
- For multiple units of equipment, ensure all equipment chassis protective grounding points are connected at equal potential.
- To improve the corrosion resistance of the terminal, it is recommended to apply silicone gel or paint over the external part of the grounding terminal for protection after the protective ground wire connection is installed.

5.4.1 Inverter Grounding

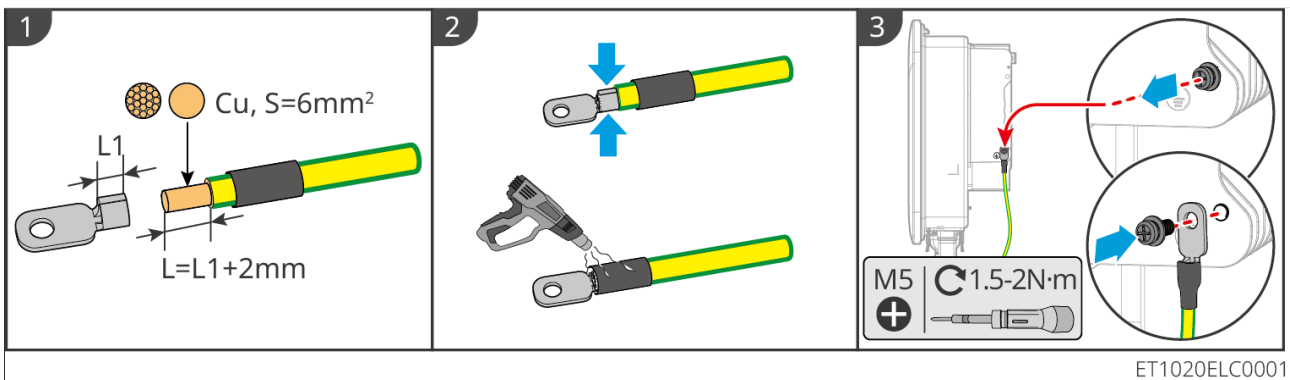

Figure28 ;

5.4.2 Battery System Grounding

NOTICE

The pull-out force after crimping should be greater than 400N.

Lynx Home F Series

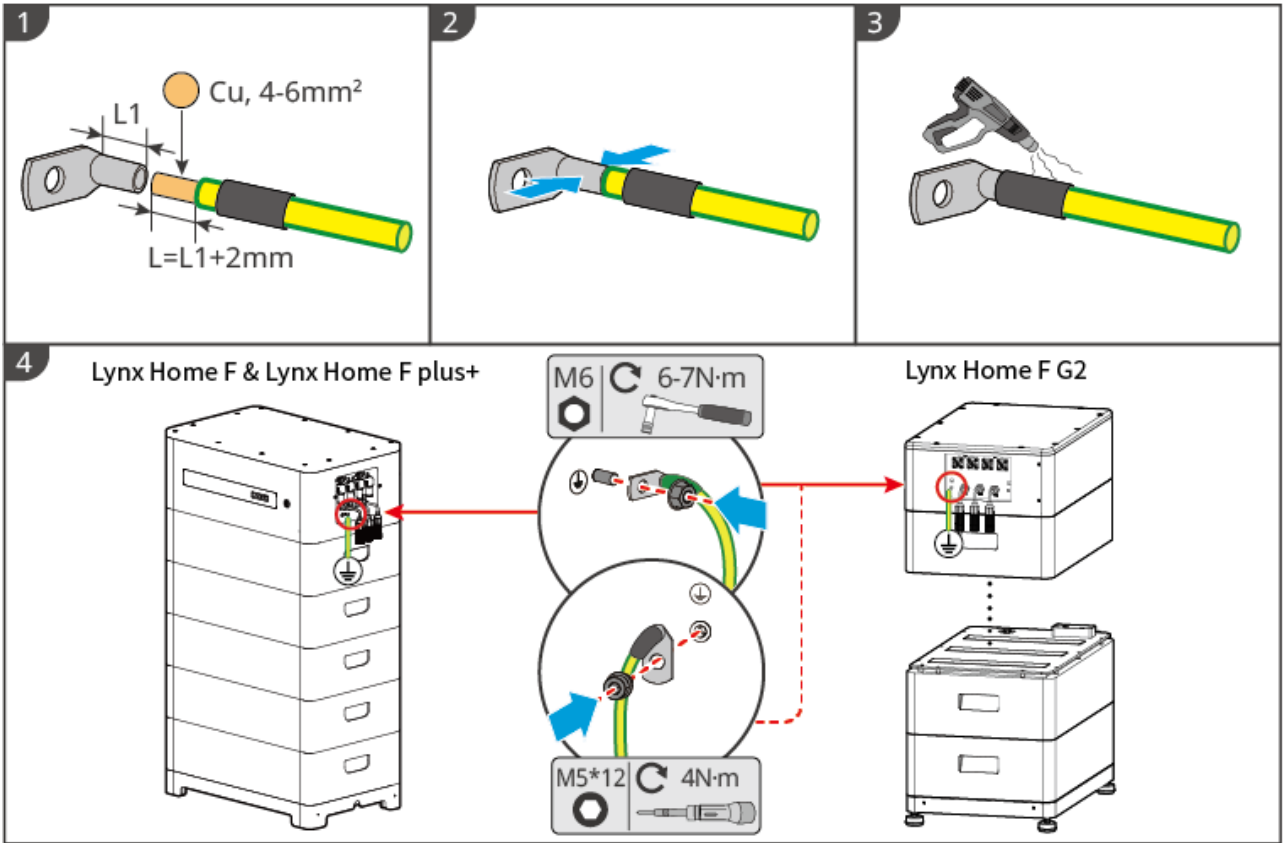

LXF10ELC0001

Lynx Home D

Within a battery system, any one grounding point can be selected for grounding.

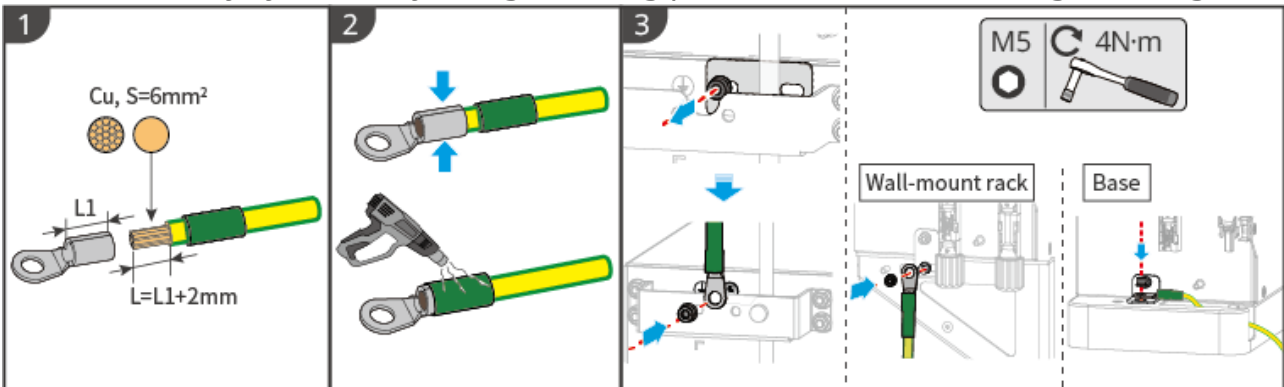

LXD10ELC0001

5.5 Connecting the PV Cable

DANGER

- Do not connect the same PV string to multiple inverters, as this may cause inverter damage.
- PV strings generate high-voltage DC electricity when exposed to sunlight. Exercise caution during electrical connections.
- Before connecting the PV strings to the inverter, confirm the following information. Failure to do so may cause permanent inverter damage, and in severe cases, may lead to fire resulting in personal injury and property loss.
 1. Ensure the maximum short-circuit current and maximum input voltage for each MPPT circuit are within the inverter's allowable range.
 2. Ensure the positive terminal of the PV string is connected to the inverter's PV+, and the negative terminal of the PV string is connected to the inverter's PV-.

WARNING

- The PV string output does not support grounding. Before connecting the PV string to the inverter, ensure the minimum insulation resistance to ground of the PV string meets the minimum insulation impedance requirement ($R = \text{Max. Input Voltage} / 30\text{mA}$).
- After completing the DC cable connection, ensure the cable connections are tight and secure, with no looseness.
- Use a multimeter to measure the positive and negative poles of the DC cable to ensure correct polarity (no reverse connection) and that the voltage is within the permissible range.

NOTICE

The two photovoltaic string arrays within each MPPT circuit must use the same model, the same number of panels, the same tilt angle, and the same azimuth angle to ensure maximum efficiency.

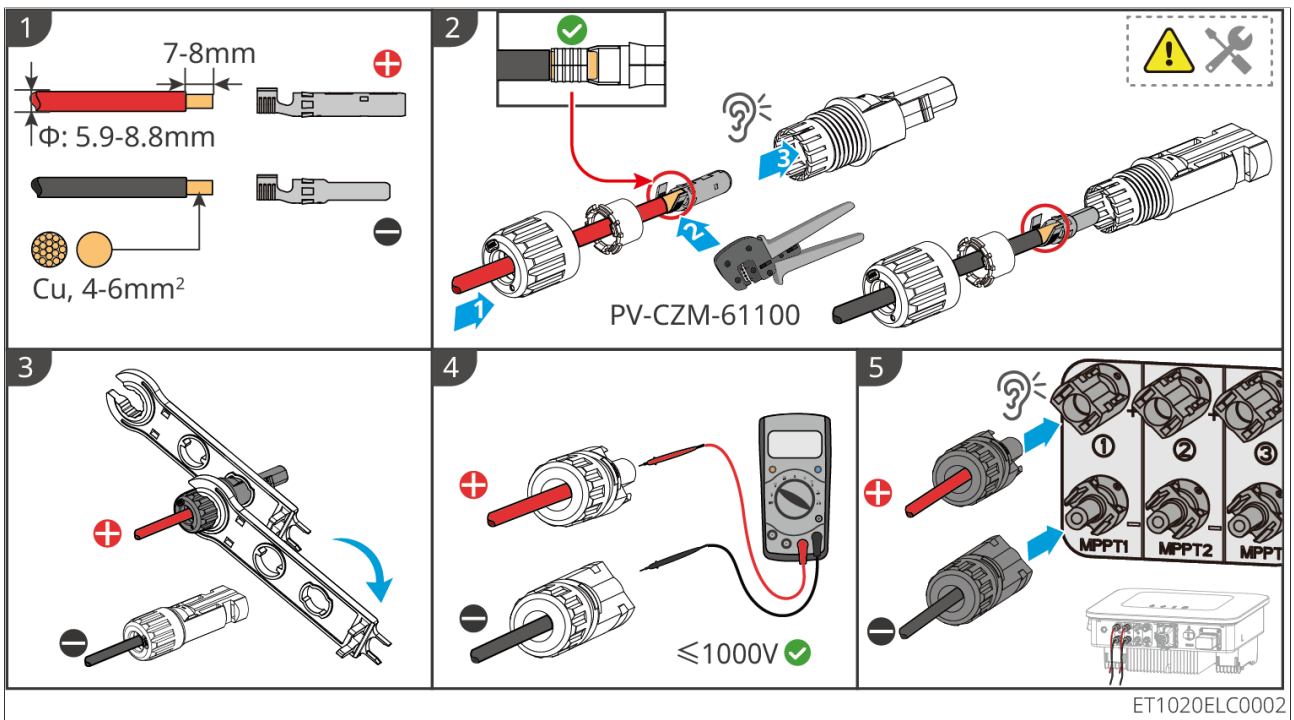

Figure29 Connecting the PV Cable

5.6 Connecting the AC Cable

 **WARNING**

- The inverter integrates a Residual Current Monitoring Unit (RCMU) internally to prevent the residual current from exceeding the specified value. When the inverter detects a leakage current greater than the allowable value, it will quickly disconnect from the grid or generator.
- Each inverter must be equipped with an AC output circuit breaker. Multiple inverters must not be connected to a single AC circuit breaker simultaneously.
- To ensure the inverter can safely disconnect from the grid in case of an abnormal condition, please install an AC circuit breaker on the AC side of the inverter. Select a suitable AC circuit breaker according to local regulations.
- When the inverter is powered on, the BACK-UP AC port is live. If maintenance is required on the BACK-UP load, power down the inverter first, otherwise electric shock may occur.
- During wiring, ensure the AC wires correspond exactly to the "L1", "L2", "L3", "N", and "PE" terminals on the AC terminal block. Incorrect cable connection will cause equipment damage.
- Ensure the wire cores are fully inserted into the terminal connection holes with no exposed parts.
- Ensure the insulation plate at the AC terminal block is securely fastened and not loose.
- Ensure the cable connections are tight. Otherwise, overheating of the terminals during equipment operation may cause equipment damage.
- According to local regulations, a Type A RCD can be installed externally to the inverter. Recommended specifications: ON-GRID side: 300mA, BACK-UP side: 30mA.

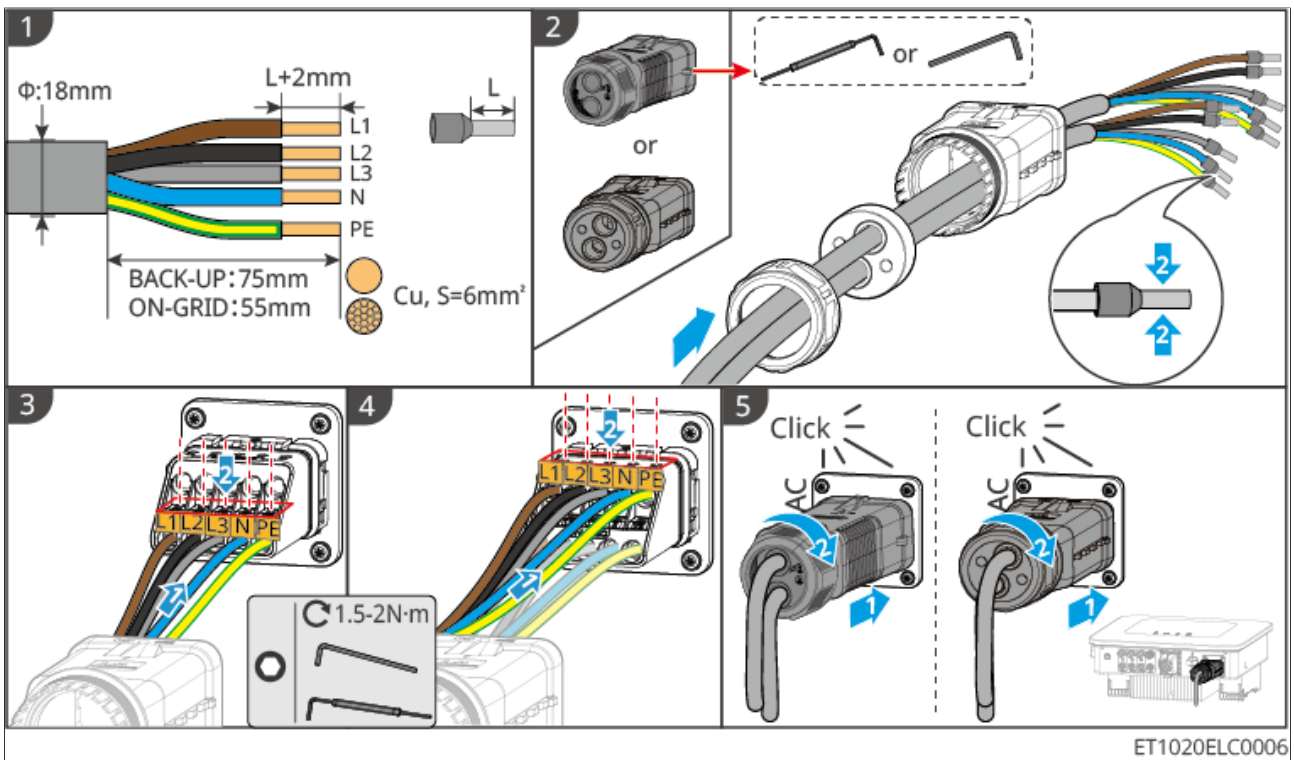

Figure30 Connecting the AC line

5.7 Connecting the Battery Cable

⚠ DANGER

- Do not connect the same battery pack to multiple inverters, as this may cause inverter damage.
- It is prohibited to connect loads between the inverter and the battery.
- When connecting battery cables, use insulated tools to prevent accidental electric shock or battery short circuits.
- Ensure that the battery open-circuit voltage is within the allowable range of the inverter.
- Between the inverter and the battery, choose whether to configure a DC switch according to local laws and regulations.

NOTICE

When using the Lynx Home D battery:

- Please select the appropriate cable crimp terminals based on the actual connected device.
- Please use suitable hydraulic pliers according to the DC connector model. The recommended specifications are:
 - For crimping battery DC terminals where the self-sealing bag in the delivery package does not have an HD Locking terminal label, it is recommended to use the YQK-70 hydraulic pliers.
 - For crimping battery DC terminals where the self-sealing bag in the delivery package has an HD Locking terminal label, it is recommended to use the VXC9 hydraulic pliers.
 - If hydraulic pliers cannot be purchased, please select a crimping tool based on the terminal crimp dimensions yourself, ensuring the terminal crimp meets usage requirements.
- Please use the DC connectors and terminals provided in the box to connect the power cables:
 - If the black power cable of the battery system has a label or white numbered sleeve with the marking HD, please mate it with the connector from the delivery package whose self-sealing bag has an HD Locking terminal label.
 - If the black power cable of the battery system does not have a label or white numbered sleeve with the marking HD, please check if the self-sealing bag containing the power connectors in the delivery package has an HD Locking terminal label. If not, mate the male and female connectors with each other; if there is an HD Locking terminal label, please contact the distributor or after-sales service.

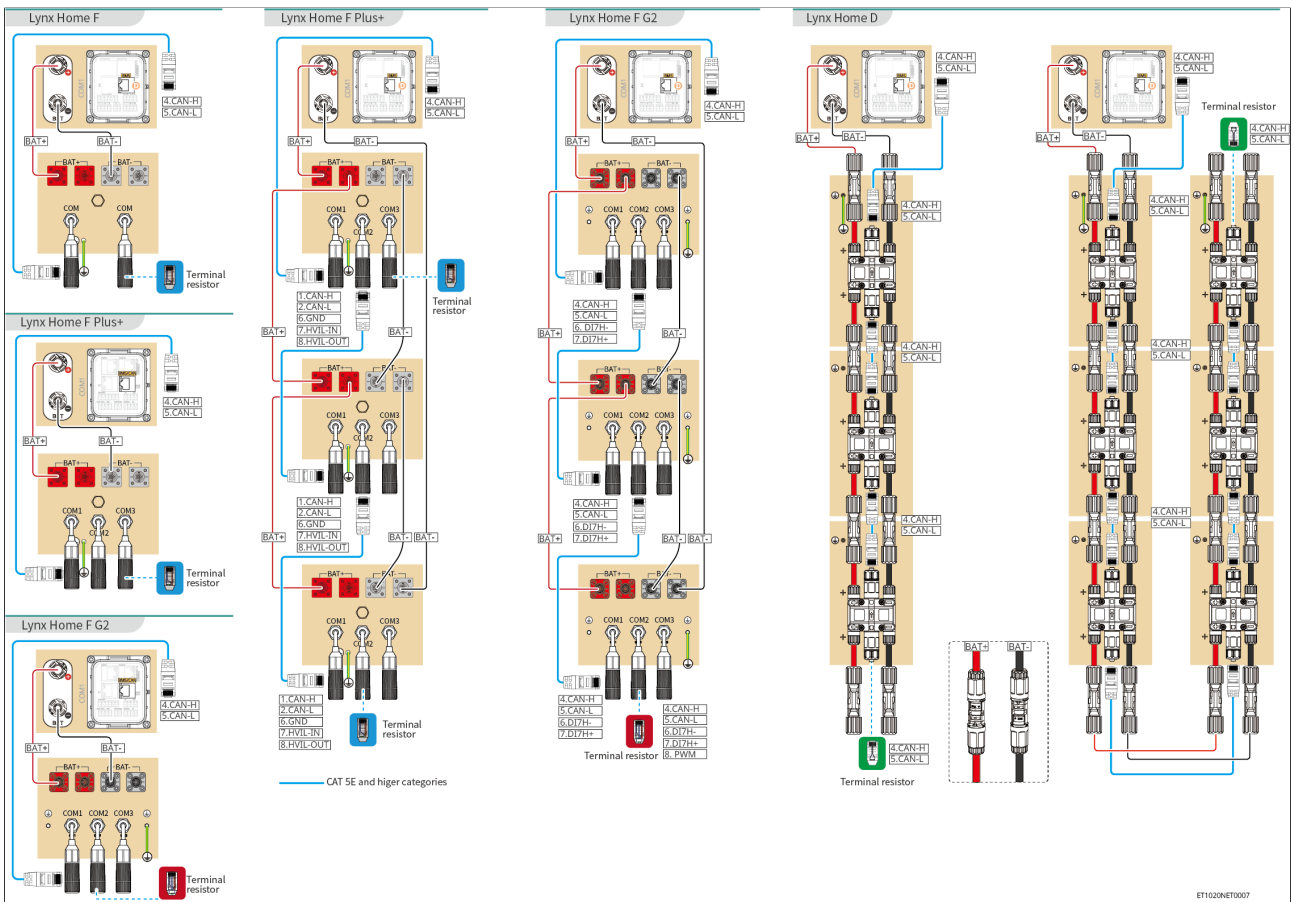

Figure 31 Battery System Wiring Diagram

BMS Communication Connection Instructions between the Inverter and the Lynx Home F Series Battery:

Inverter Port	Connected to Battery Port	Port Definition	Description
BMS	COM1/COM2/COM	4: CAN_H 5: CAN_L	CAN communication is used between the inverter and the battery.

Lynx Home F Communication Port Definition:

PIN	COM	Description
4	CAN_H	Connect to the inverter BMS Communication Port to communicate with the inverter; or termination resistor.
5	CAN_L	

PIN	COM	Description
1, 2, 3, 6, 7, 8	-	-

Lynx Home F Plus+ Battery Cluster Parallel Communication Connection

Instructions:

PIN	COM1	COM2	COM3	Description
1	CAN_H	CAN_H	CAN_H	BMS communication for battery system parallel clusters
2	CAN_L	CAN_L	CAN_L	
3	-	-	-	Reserved
4	CAN_H	-	-	<ul style="list-style-type: none"> COM1: Connect to the inverter BMS Communication Port for communication with the inverter. COM2, COM3: Reserved.
5	CAN_L	-	-	
6	GND	GND	GND	Ground PIN
7	HVIL_IN	HVIL_IN	-	<ul style="list-style-type: none"> COM1, COM2: Interlock function for parallel clusters. COM3: Reserved.
8	HVIL_OUT	HVIL_OUT	-	

Lynx Home F G2 Battery Cluster Parallel Communication Connection

Instructions:

PIN	COM1	COM2	COM3	Description
1	RS485_A1	RS485_A1	Reserved	Connect to external RS485 communication device
2	RS485_B1	RS485_B1		
3	-	-		Reserved
4	CAN_H	CAN_H		Connect to inverter communication or battery cluster communication port
5	CAN_L	CAN_L		Battery cluster signal detection function
6	DI7H-	DI7H-		Send cluster PWM signal
7	DI7H+	DI7H+		
8	-	PWM		

Inverter and Lynx Home D Battery Communication Connection Instructions

Inverter Port	Connect to Battery Port	Port Definition	Description
BMS1	COM	4: CAN_H 5: CAN_L	<ul style="list-style-type: none"> The Inverter and the battery communicate via CAN. Connect the Inverter's BMS1 port to the battery communication port.

Lynx Home D Battery Communication Port Definition

PIN	Battery Port	Description
1	RS485_A1	Reserved
2	RS485_B1	
4	CAN_H	Connect to inverter communication or battery cluster communication port
5	CAN_L	
3、 6、 7、 8	-	-

5.7.1 Connecting the Power Cable between the Inverter and Battery

!WARNING

- Use a multimeter to measure the positive and negative poles of the DC cable, ensuring correct polarity without reverse connection; and the voltage is within the allowable range.
- During wiring, ensure that the battery cables match the battery terminals 'BAT+', 'BAT-', and grounding port exactly. Incorrect cable connection may cause equipment damage.
- Ensure that the wire cores are fully inserted into the terminal connection holes without exposure.
- Ensure that cable connections are tight; otherwise, during equipment operation, terminal overheating may occur, leading to equipment damage.
- Do not connect the same battery bank to multiple inverters, as this may cause inverter damage.

Inverter+ Lynx Home F Series Battery

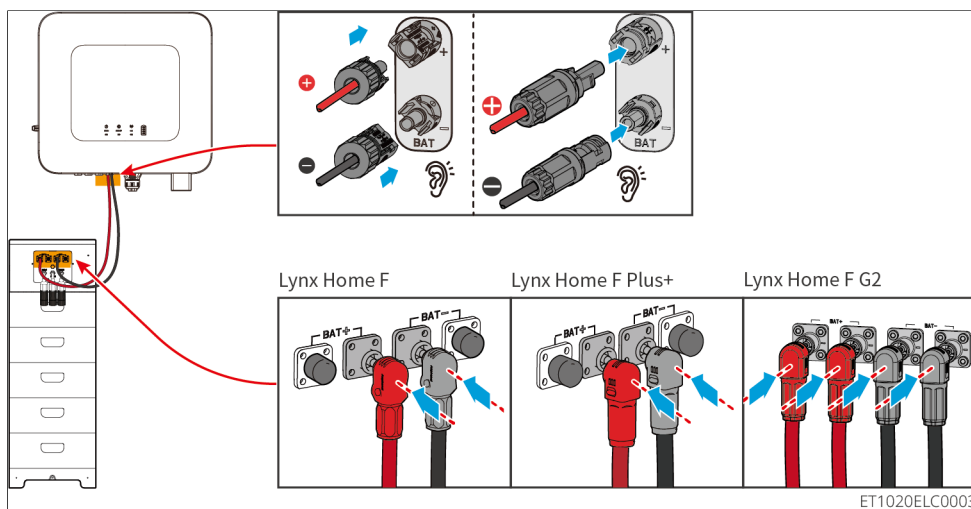

Figure32 Inverter + Lynx Home F Series Battery

Inverter+ Lynx Home D Battery

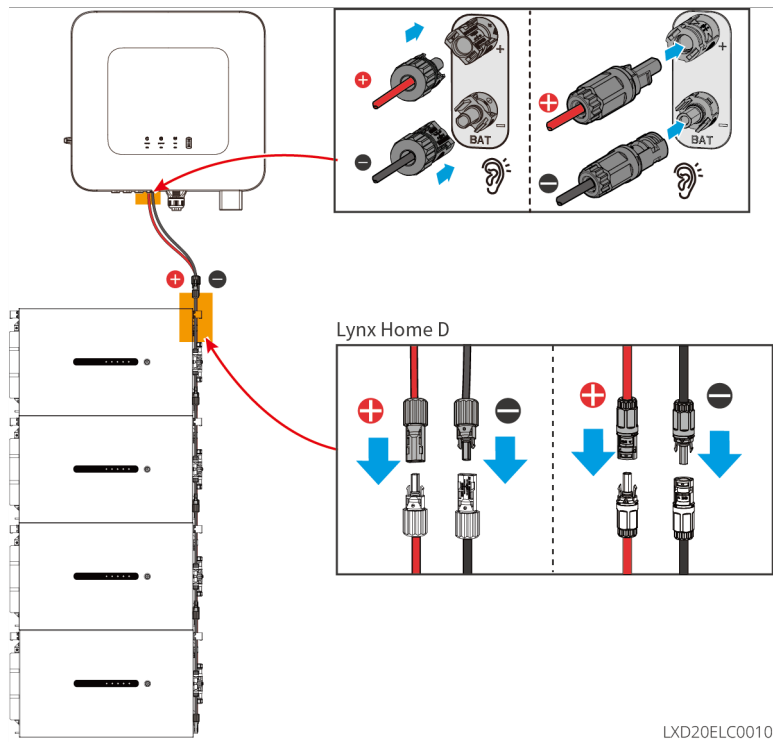

Figure33 Inverter + Lynx Home D Battery

Inverter-End Cable Assembly

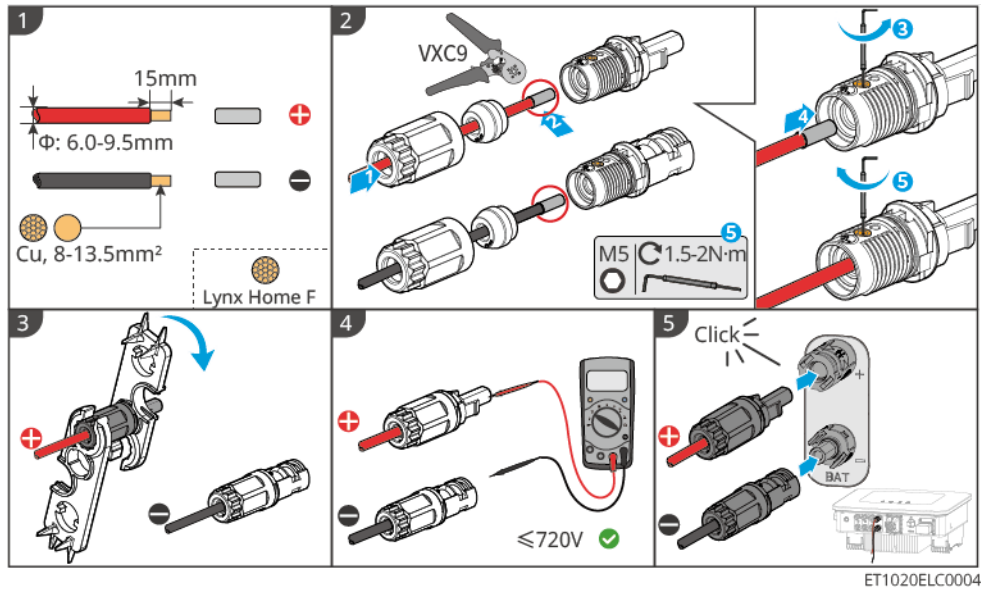

Figure34 Type 1

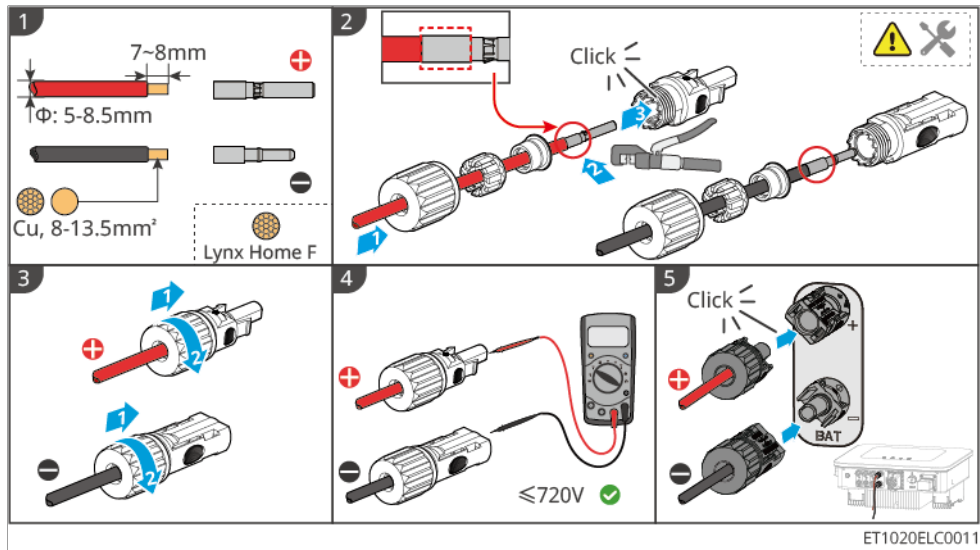

Figure35 Type 2

Battery-End Cable Assembly Method (Lynx Home F)

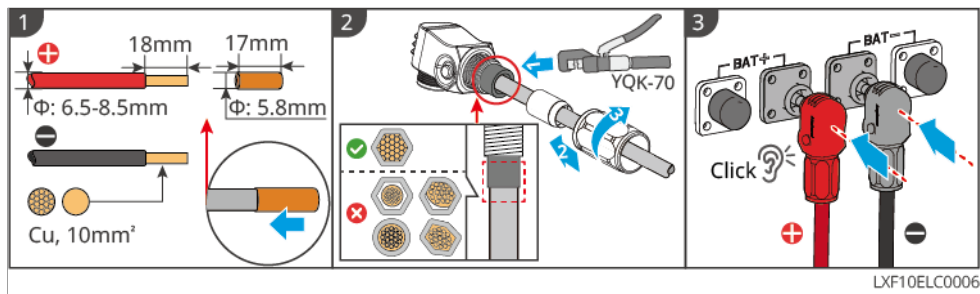

Figure36 Lynx Home F

Battery-End Cable Assembly Method (Lynx Home F Plus+)

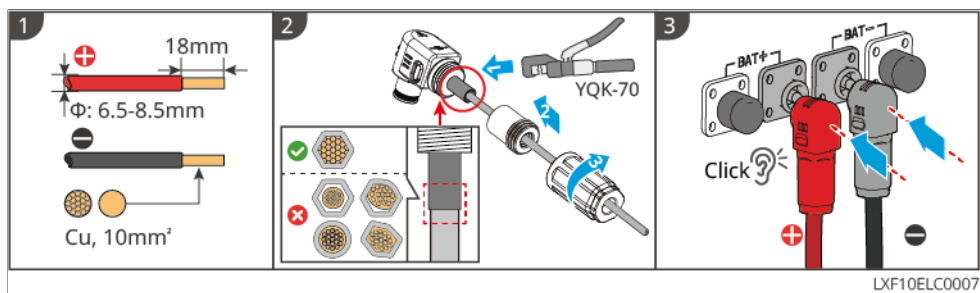

Figure37 Lynx Home F Plus+

Battery-End Cable Assembly Method (Lynx Home F G2)

⚠ WARNING

- Please prepare your own DC input cable. Recommended specifications:
 - Type: Outdoor single-core copper wire
 - Conductor cross-sectional area S : 6mm^2 or 10mm^2
- When the conductor cross-sectional area S is 6mm^2 , please use the DC connector labeled 6mm^2 in the packaging bag, and the pull-out force after cable crimping should be $>450\text{N}$. When using DC cables of this specification, only a single battery system is supported. Do not cluster battery systems, otherwise it may cause equipment damage.
- When using cable cross-sectional area S as 10mm^2 , please use the DC connector labeled 10mm^2 in the packaging bag, and the pull-out force after cable crimping should be $>500\text{N}$.
- It is recommended to use the YQK-70 hydraulic crimper for battery DC terminal crimping: when the conductor cross-sectional area is 6mm^2 , select the crimping die labeled "6"; when the conductor cross-sectional area is 10mm^2 , select the crimping die labeled "10".
- Please select the tool for crimping battery DC terminals according to actual needs. The tools in the graphics are for illustration only.
- If the DC port does not need to be connected to a cable, do not remove the protective cover of the DC port, otherwise it may affect the equipment's protection rating.

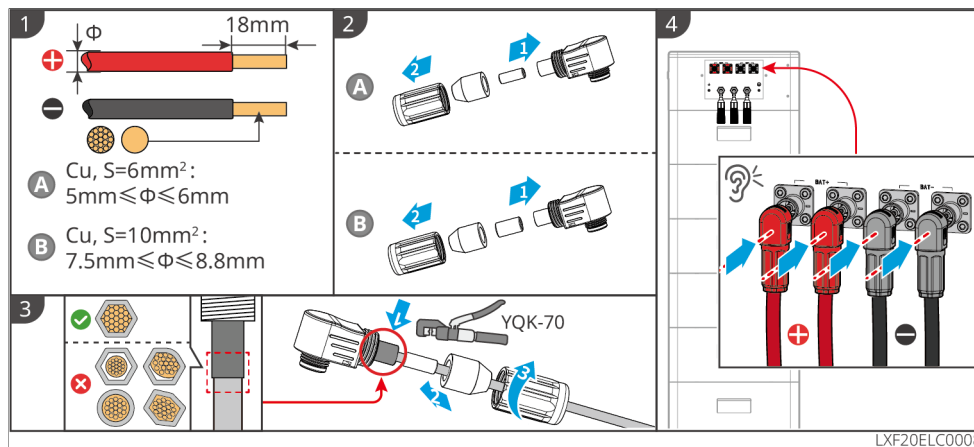

Figure38 Lynx Home F G2

Battery-End Cable Assembly Method (Lynx Home D)

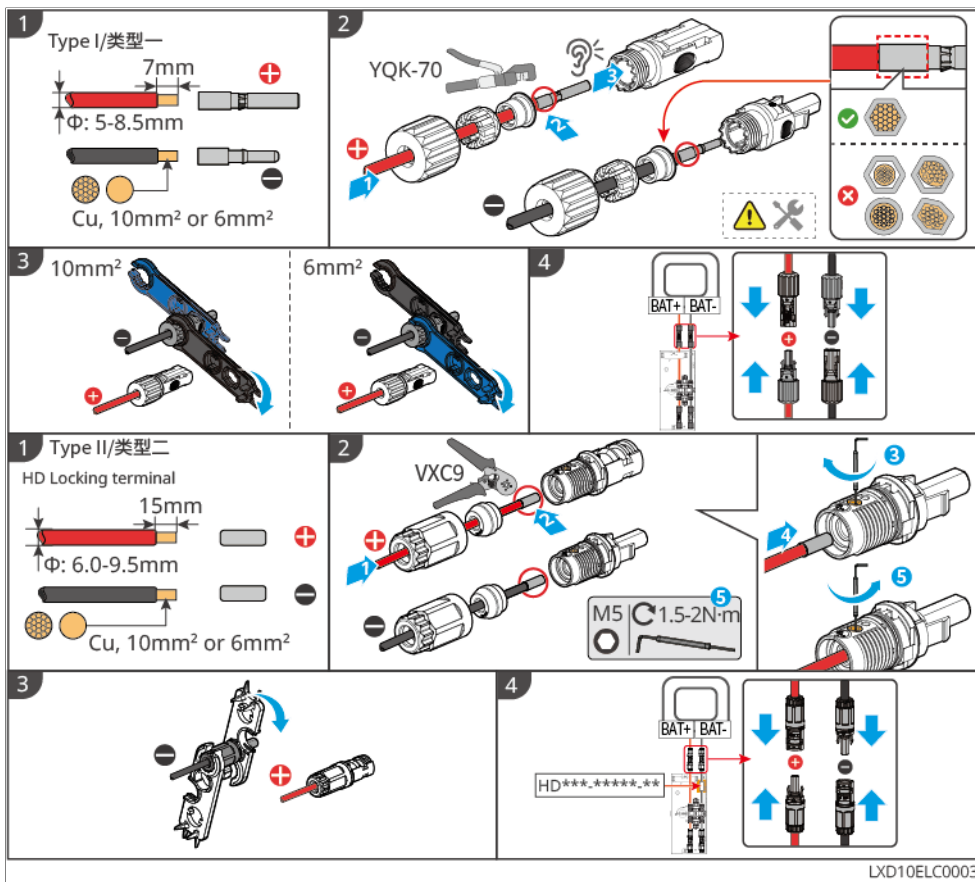

Figure39 Lynx Home D

5.7.2 Connecting the Communication Cable between the Inverter and Battery

NOTICE

The inverter comes with a BMS battery communication cable in the package. It is recommended to use the provided BMS battery communication cable. If the supplied communication cable does not meet your requirements, please prepare your own shielded network cable and RJ45 connectors.

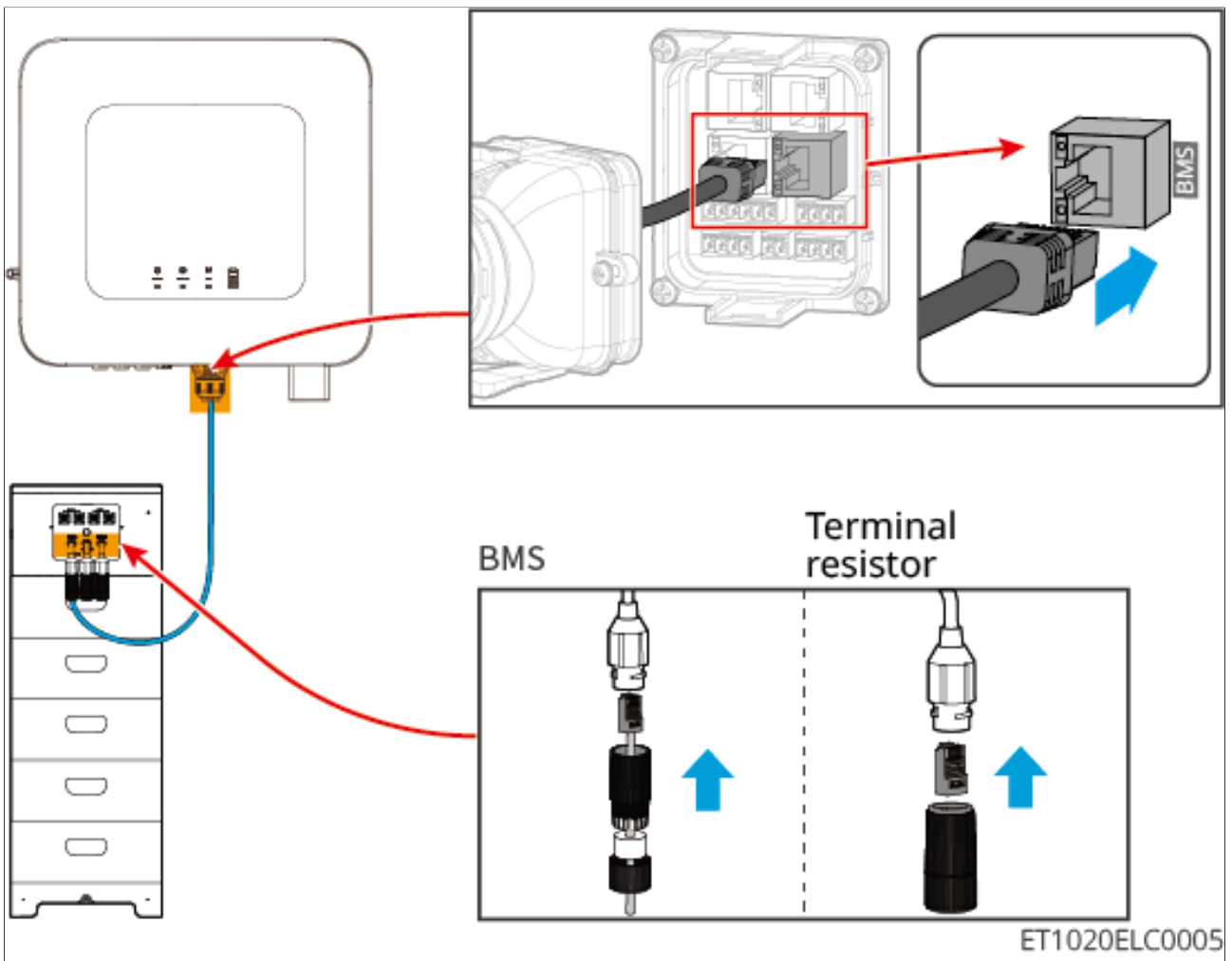

Figure40 Inverter + Lynx Home F Series Battery

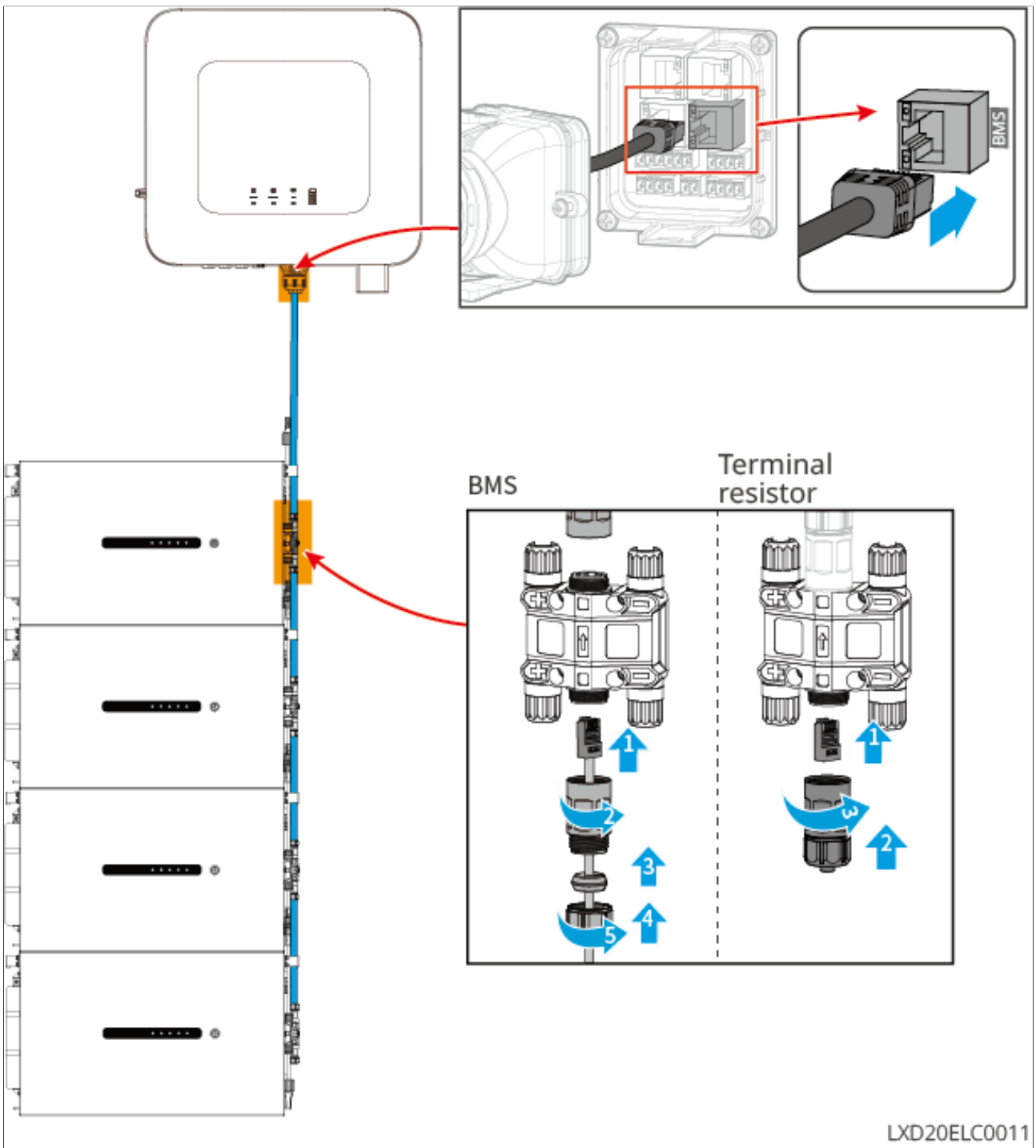

Figure41 Inverter + Lynx Home D Battery

5.7.3 Connecting Lynx Home D Inter-Battery Power Cables

Crimping the Power Cables

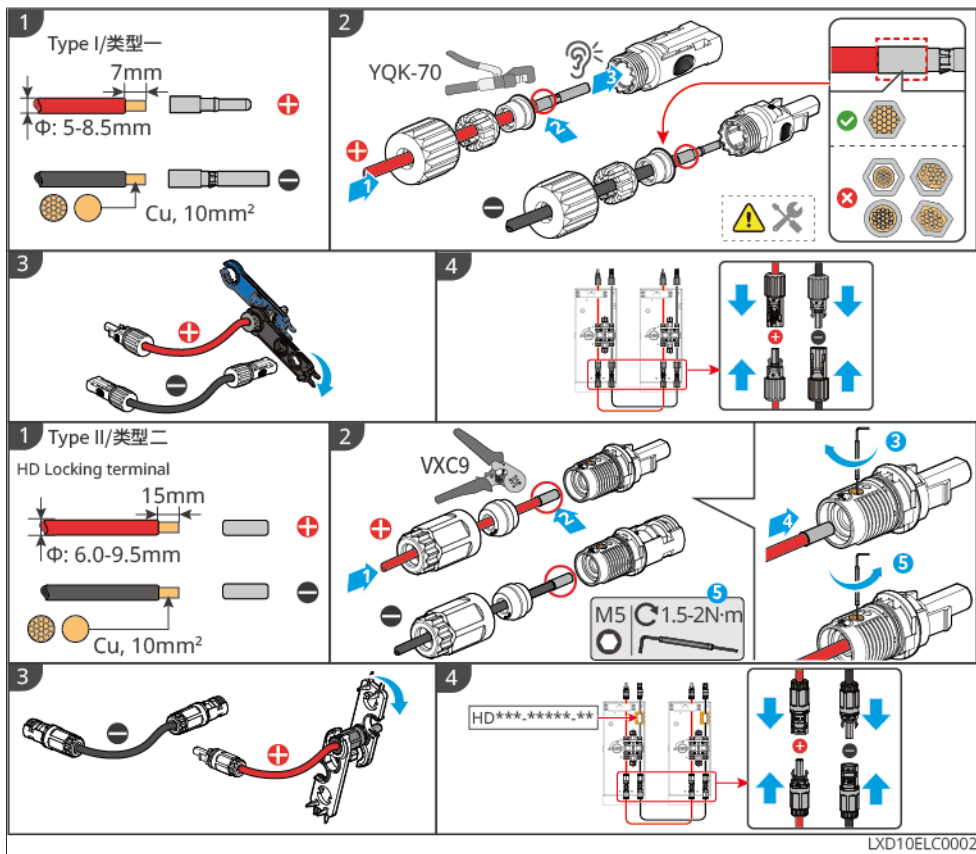

Figure42 Crimping the power cables

Connecting the Power Cables

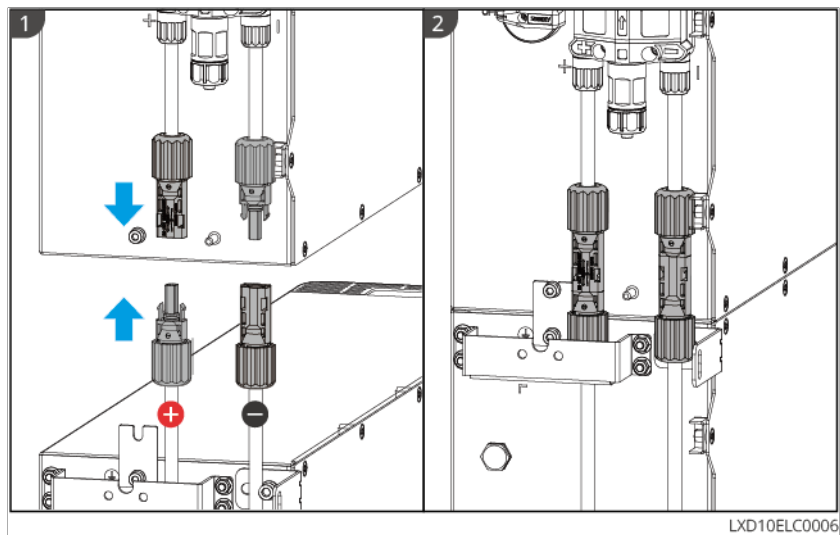

Figure43 Type 1

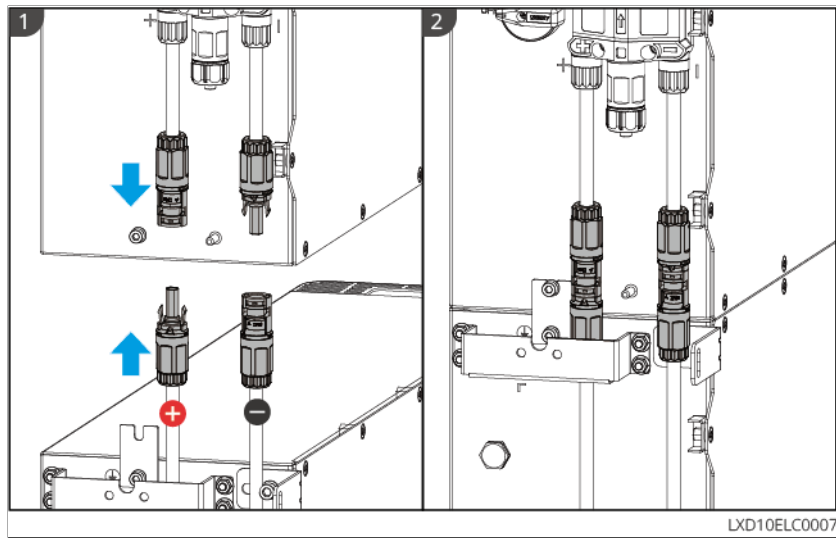

Figure44 Type 2

To remove the power connector, please use the tool provided in the shipment and refer to the following steps.

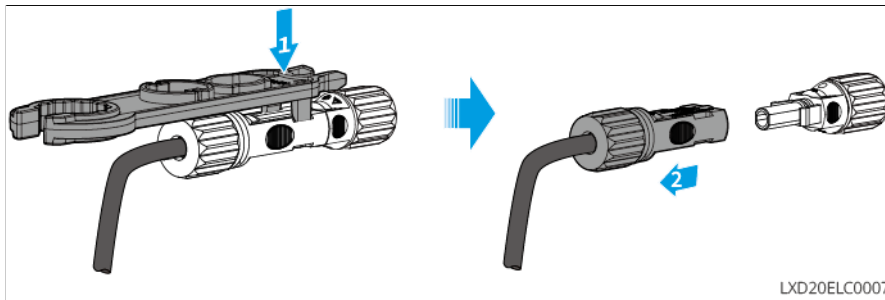

Figure45 Type 1

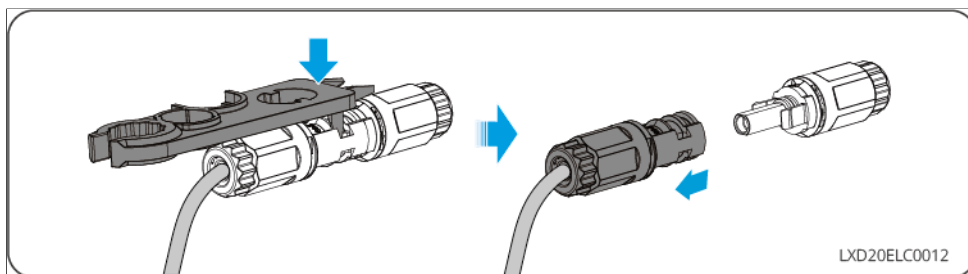

Figure46 Type 2

5.7.4 Connecting Battery Communication Cable and Terminal

Resistor

Please use the battery communication cable and terminal resistor shipped with the box.

WARNING

- Do not omit the battery system terminal resistor, otherwise it will cause the battery system to malfunction.
- Do not disassemble the waterproof plug during installation.

Lynx Home DBattery

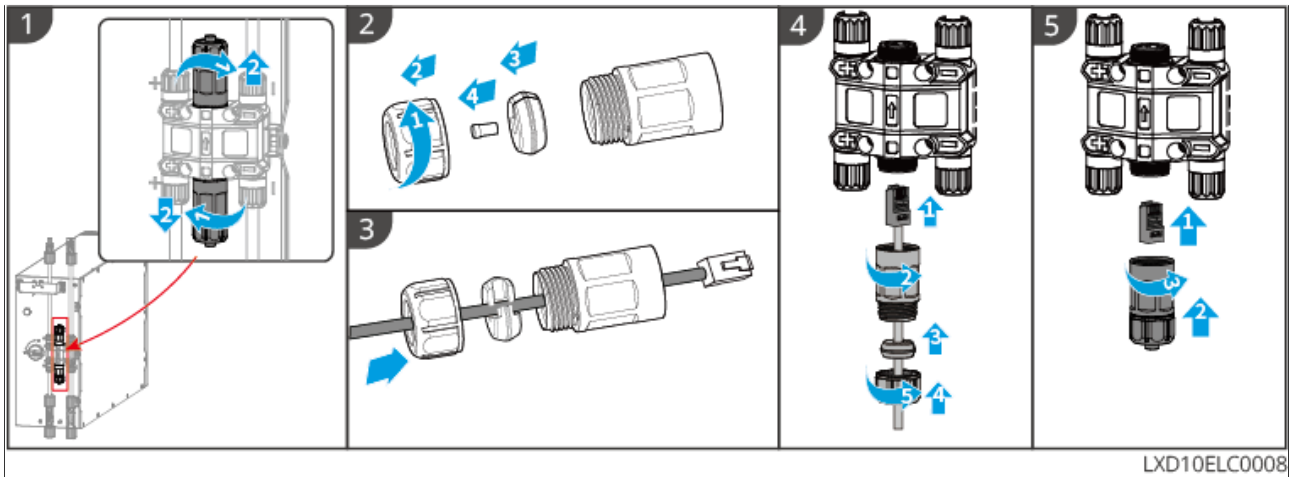

Figure47 Connecting communication cable and terminal resistor

Lynx Home F G2

1. Remove the waterproof component.
2. Pass the communication cable through the waterproof component.
3. Connect the communication cable to the battery, or install the terminal resistor.
Tighten the waterproof component.

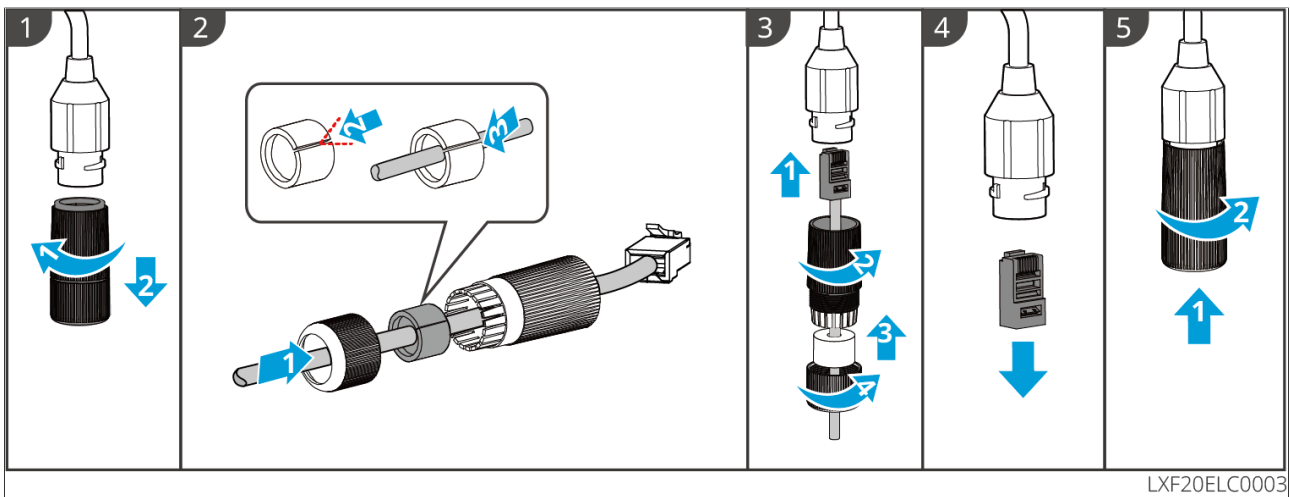

Figure48 Connecting communication cable and terminal resistor

5.8 Connecting the Meter Cable

NOTICE

- The meter shipped with the box is for use with only one inverter. Do not connect one meter to multiple inverters. If you need to use multiple inverters, consult the manufacturer to purchase meters separately.
- Ensure that the CT connection direction and phase sequence are correct; otherwise, monitoring data may be inaccurate.
- Ensure that all cables are connected correctly, securely, and without looseness. Improper wiring may cause poor contact or damage the meter.
- In areas with lightning risk, if the meter cable length exceeds 10m and the cables are not wired with grounded metal conduits, it is recommended to install external lightning protection devices.

GM3000 Meter Wiring

NOTICE

- The outer diameter of the AC power line must be smaller than the aperture of the CT to ensure the AC power line can pass through the CT.
- To ensure the current detection accuracy of the CT, the recommended length of the CT cable does not exceed 30m.
- Do not use network cable as the CT cable, as excessive current may cause damage to the meter.
- The CT provided by equipment manufacturers may vary slightly in size and appearance depending on the model, but the installation and wiring methods are the same.

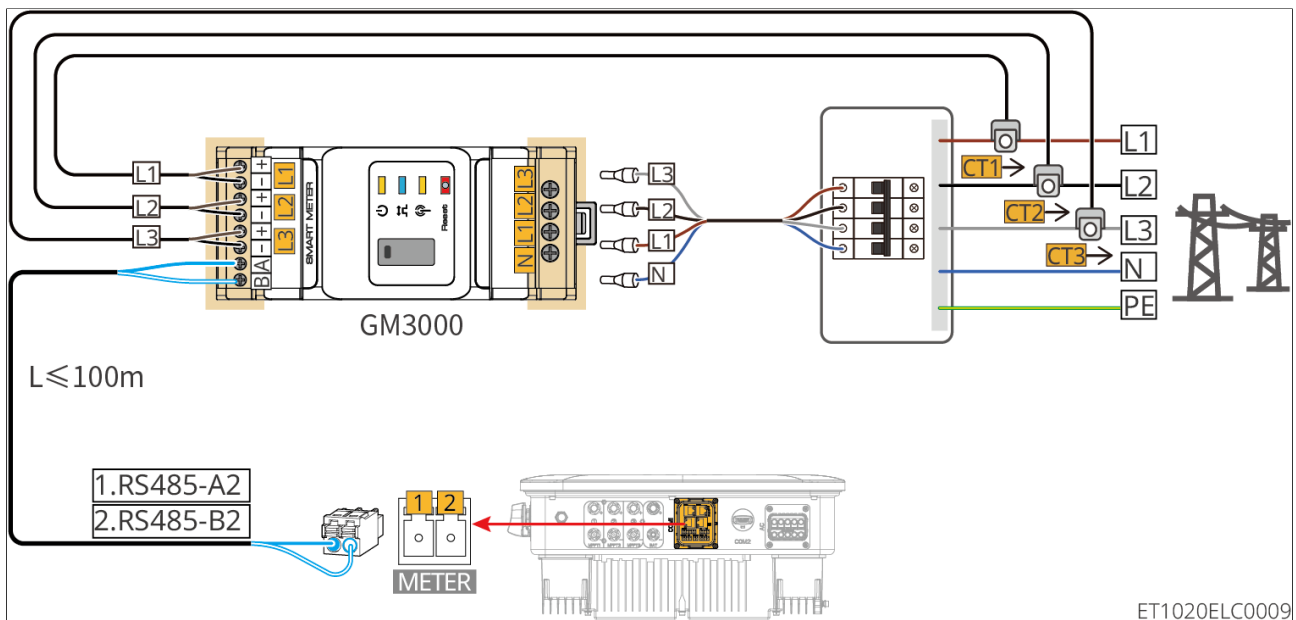

Figure49 GM3000 Meter Wiring Diagram

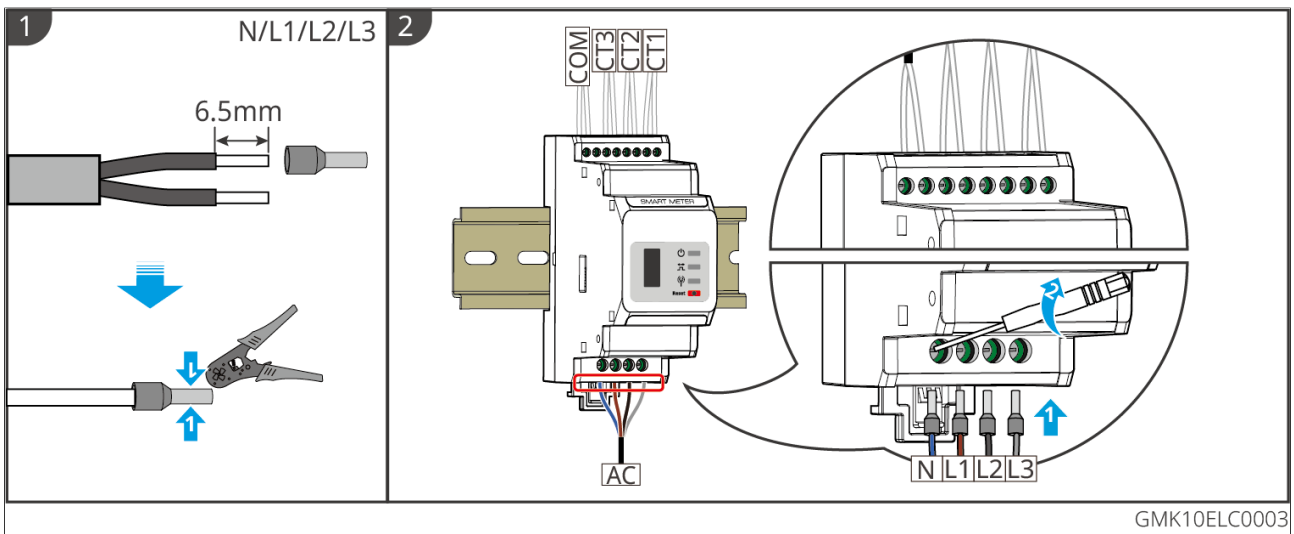

Figure50 Wiring Steps

GM330 Meter Wiring

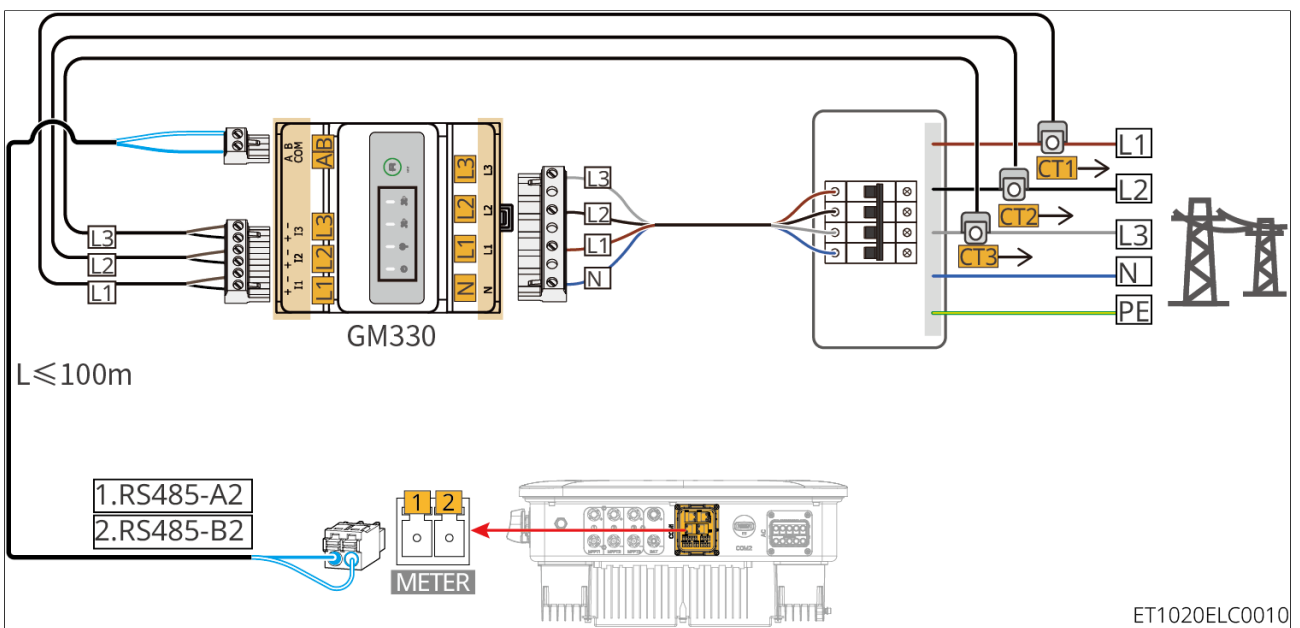

Figure51 GMK330 Meter Wiring Diagram

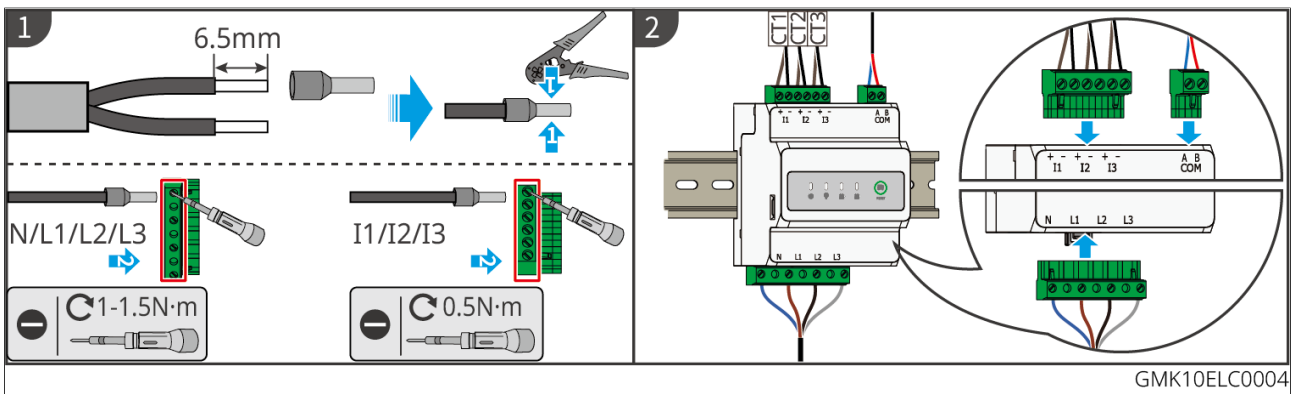

Figure52 Wiring Steps

Installing CT

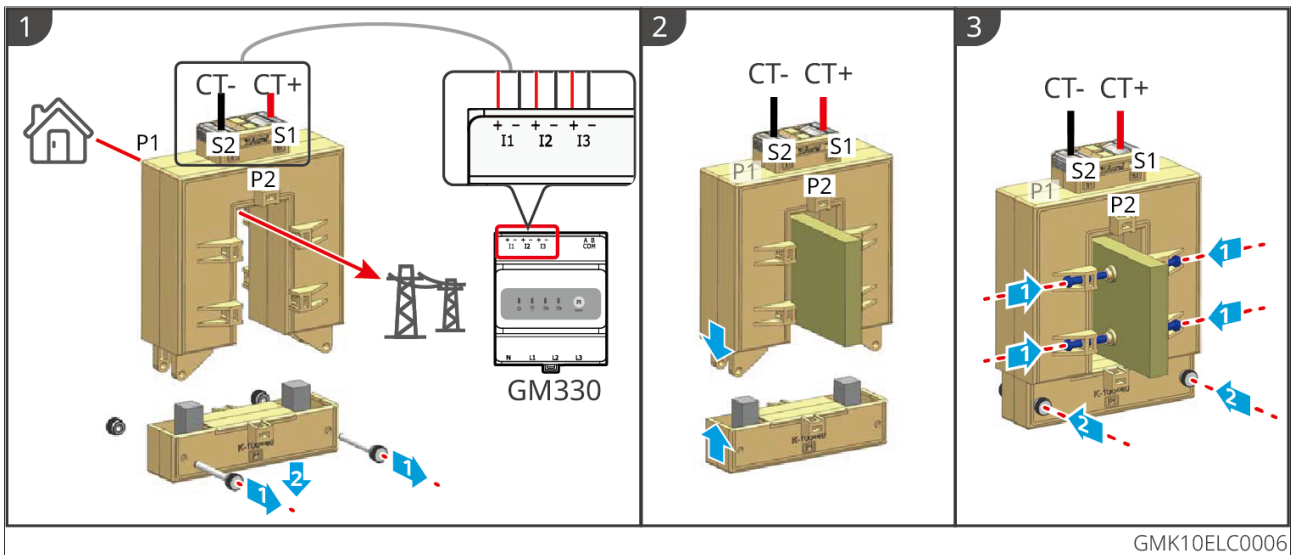

Figure53 Type One

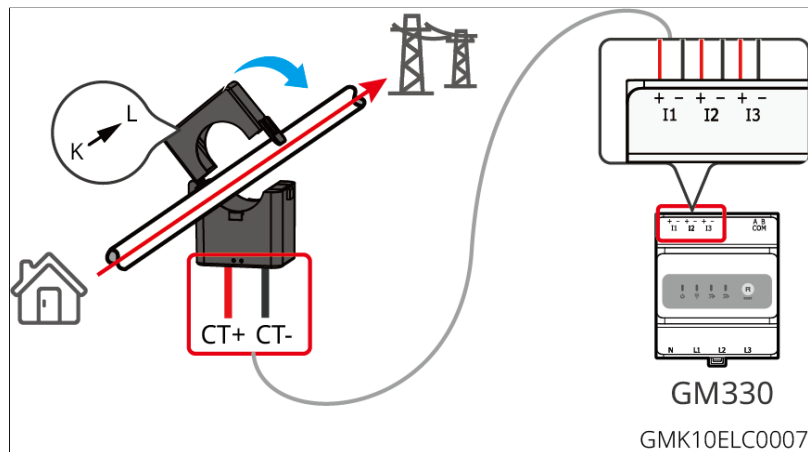

Figure54 Type Two

5.9 Connecting the Inverter Communication Cable

NOTICE

- When using the built-in meter of the Inverter for networking in a parallel system, only the master Inverter needs to be connected to CT, and the slave Inverters do not need to be connected to CT.
- When using the built-in meter, please use the CT that comes with the shipment.
- To ensure the normal use of the meter and CT, please ensure the following:
 - Please ensure that the CT is connected matching the phase lines, with CT1 connected to L1, CT2 connected to L2, and CT3 connected to L3.
 - Please connect according to the direction of the CT, otherwise it may cause CT reverse fault.
 - When replacing or maintaining the CT later, please use the 'Meter/CT Auxiliary Detection Function' on the SolarGo APP to make the Inverter readapt to the CT sampling current direction.
- If you need to use the DRED, RCR, or remote shutdown function, after wiring is completed, please turn on this function in the SolarGo APP.
- If the Inverter is not connected to DRED device or remote shutdown device, do not turn on this function in the SolarGo APP, otherwise the Inverter cannot operate in grid-connected mode.
- In a parallel system, if you need to implement the DRED and RCR functions, only connect the DRED and RCR communication lines to the master Inverter; if you need to implement the remote shutdown function, connect the remote

NOTICE

shutdown communication lines to all Inverters.

- The Inverter's DO signal communication port can connect dry contact signal specifications: Max \leq 24Vdc, 1A.
- To ensure communication quality, do not connect the parallel communication port PAR1 of one Inverter to the parallel communication port PAR1 of another Inverter; you need to connect the parallel communication port PAR1 of one Inverter to the parallel communication port PAR2 of another Inverter.
- For Inverter parallel communication cables, if using CAT 5E or CAT 6E standard shielded network cables, the recommended length is \leq 5m; if using CAT 7E standard shielded network cables, the recommended length is \leq 10m; do not exceed 10m for communication cables, otherwise it may cause communication abnormalities.
- The Inverter parallel DIP switch is set to the ON position by default at the factory.
- If you need to use the EnWG 14a function, please ensure that the Inverter's ARM software version is 13.435 or above, and the SolarGo version is 6.0.0 or above.
- If you need to pair with dual meters to achieve grid-connected machine power generation monitoring and load power consumption monitoring, please use an RJ45 splitter for connection. Prepare the RJ45 splitter yourself or contact GoodWe to purchase.
- To ensure the Inverter's waterproof rating, do not remove the waterproof plugs from unused communication ports on the Inverter.
- The Inverter communication function is optional, please select according to the actual usage scenario.

Communication Function Description

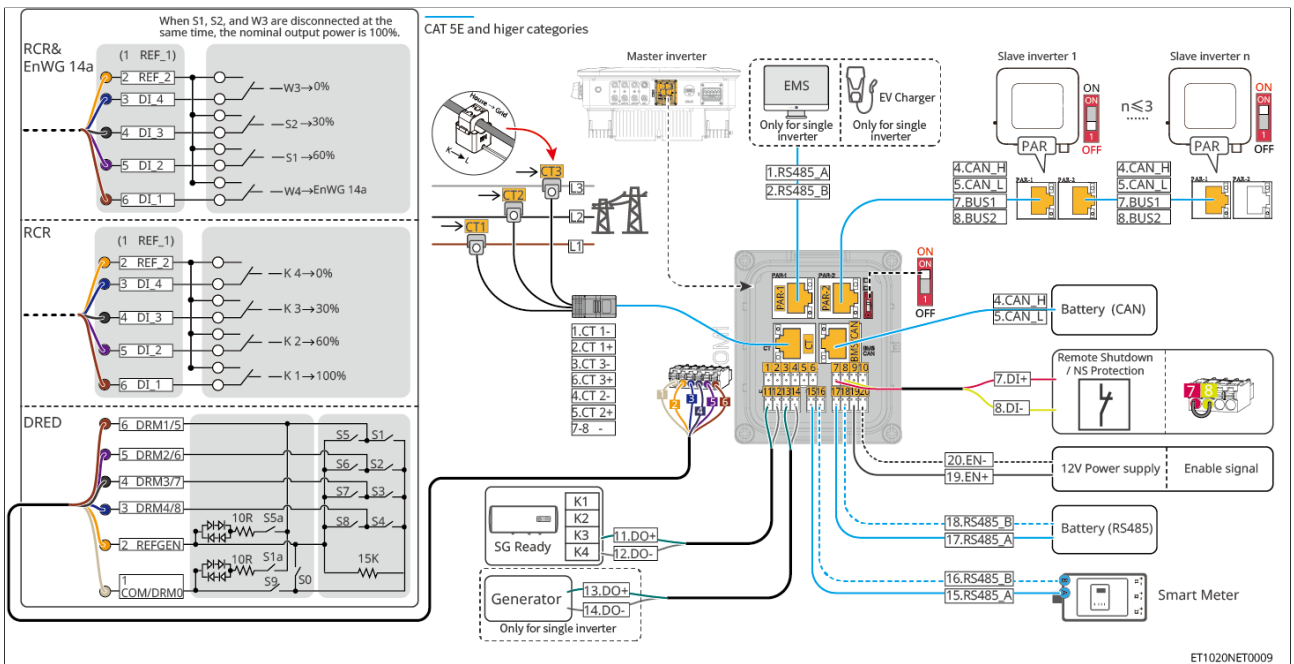

Figure55 Type One

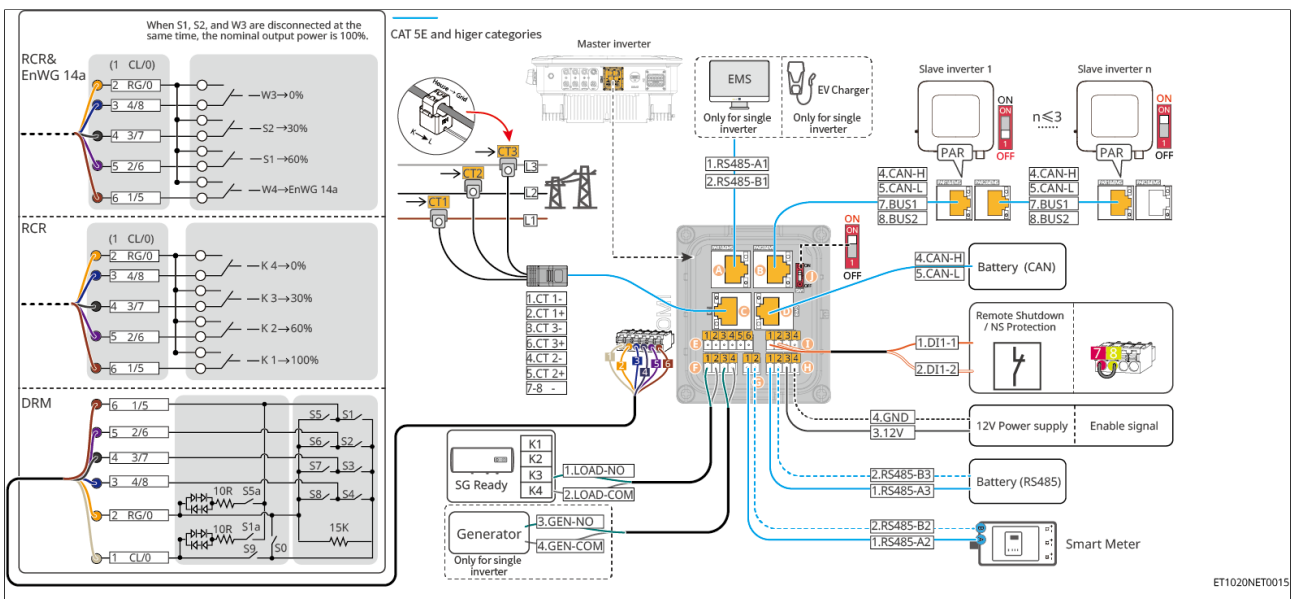

Figure56 Type Two

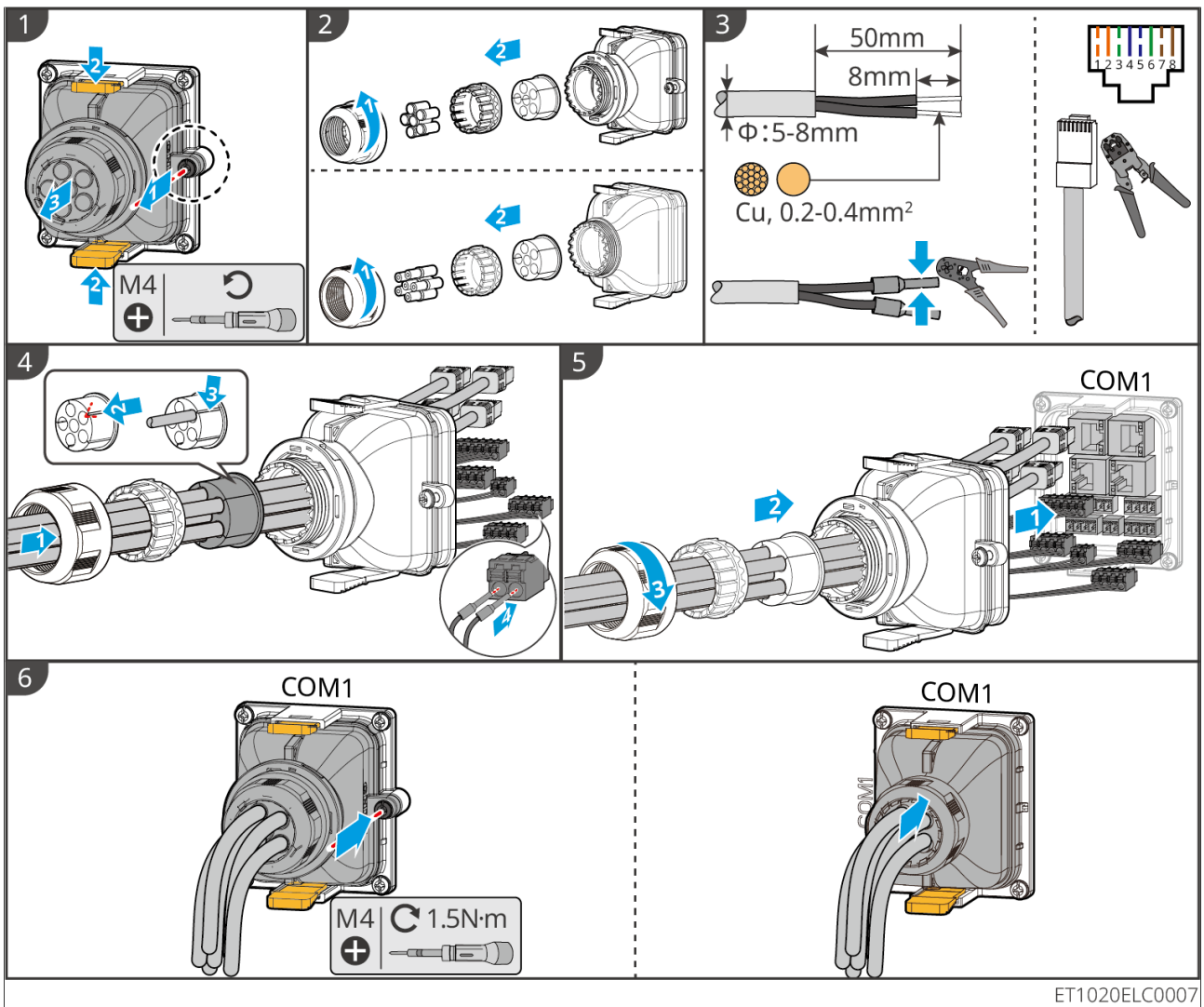

Figure57 Connecting the Communication Cable

5.10 Connecting the Smart Communication Stick

NOTICE

- The inverter supports connecting to a mobile phone or WEB interface via Bluetooth, 4G, WiFi, LAN Smart Dongle to set device-related parameters, view device operation information and error messages, and stay informed about the system status in a timely manner.
- When the system contains multiple inverters for unit networking, the master inverter needs to install the Ezlink3000 Smart Dongle for networking.
- When the energy storage system has only one inverter, the WiFi/LAN Kit-20 or 4G Smart Dongle can be used.
- When using the WiFi or LAN communication method to connect the inverter to a router, the WiFi/LAN Kit-20 or Ezlink3000 Smart Dongle can be installed.
- When using the 4G communication method to upload the energy storage system's operation information to the monitoring platform, the LS4G Kit-CN, 4G Kit-CN, 4G Kit-CN-G20, or 4G Kit-CN-G21 Smart Dongle can be installed. When using LS4G Kit-CN or 4G Kit-CN, it is necessary to use the Smart Dongle shipped with the inverter to configure the parameters for the energy storage system. After configuration is complete, replace it with the LS4G Kit-CN or 4G Kit-CN for data transmission. When using 4G Kit-CN-G20 or 4G Kit-CN-G21, please use the Bluetooth signal emitted by the module for local device configuration.
- The 4G module is an LTE single-antenna device, suitable for application scenarios with lower requirements for data transmission rates.
- The built-in SIM card in the 4G module is a China Mobile communication card. Please confirm whether the device is installed in an area covered by China Mobile's 4G signal.
- After installing the 4G Kit-CN-G20 or 4G Kit-CN-G21 communication dongle, please contact the after-sales service center to bind the inverter with the communication dongle. After binding, if you need to install the communication dongle on another inverter, please first contact the after-sales service center to unbind it.
- To ensure 4G signal communication quality, do not install the device indoors or in areas with metal interference signals.

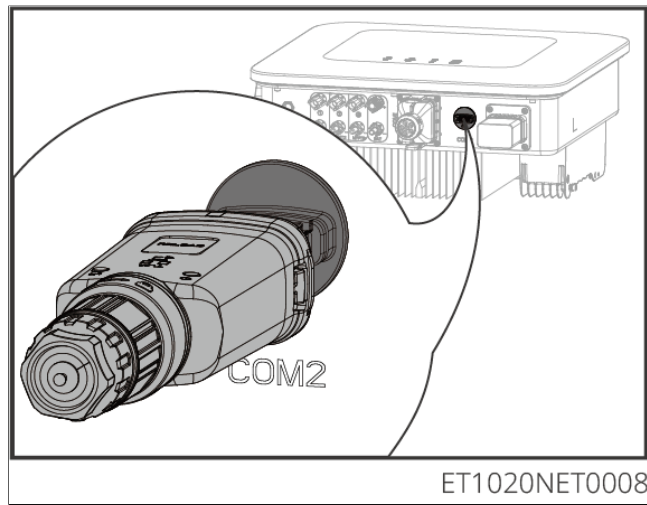

Figure58 Connecting the Communication Stick

6 System Commissioning

6.1 Check Before Power ON

No.	Inspection Item
1	The equipment is installed securely, in a location convenient for operation and maintenance, with sufficient space for ventilation and heat dissipation, and in a clean and tidy environment.
2	The PE cable, DC cable, AC cable, Communication cable, and termination resistor are connected correctly and securely.
3	Cable bundling meets routing requirements, is reasonably distributed, and shows no damage.
4	For unused cable entry holes and ports, ensure they are reliably connected using the terminals provided with the accessories and have been sealed.
5	Ensure that used cable entry holes have been sealed.
6	The voltage and frequency at the inverter's grid connection point meet the grid-connection requirements.

6.2 Power ON

 **WARNING**

When powering on the parallel system, please ensure that all slave inverters are powered on at the AC side within one minute after the master inverter is powered on at the AC side.

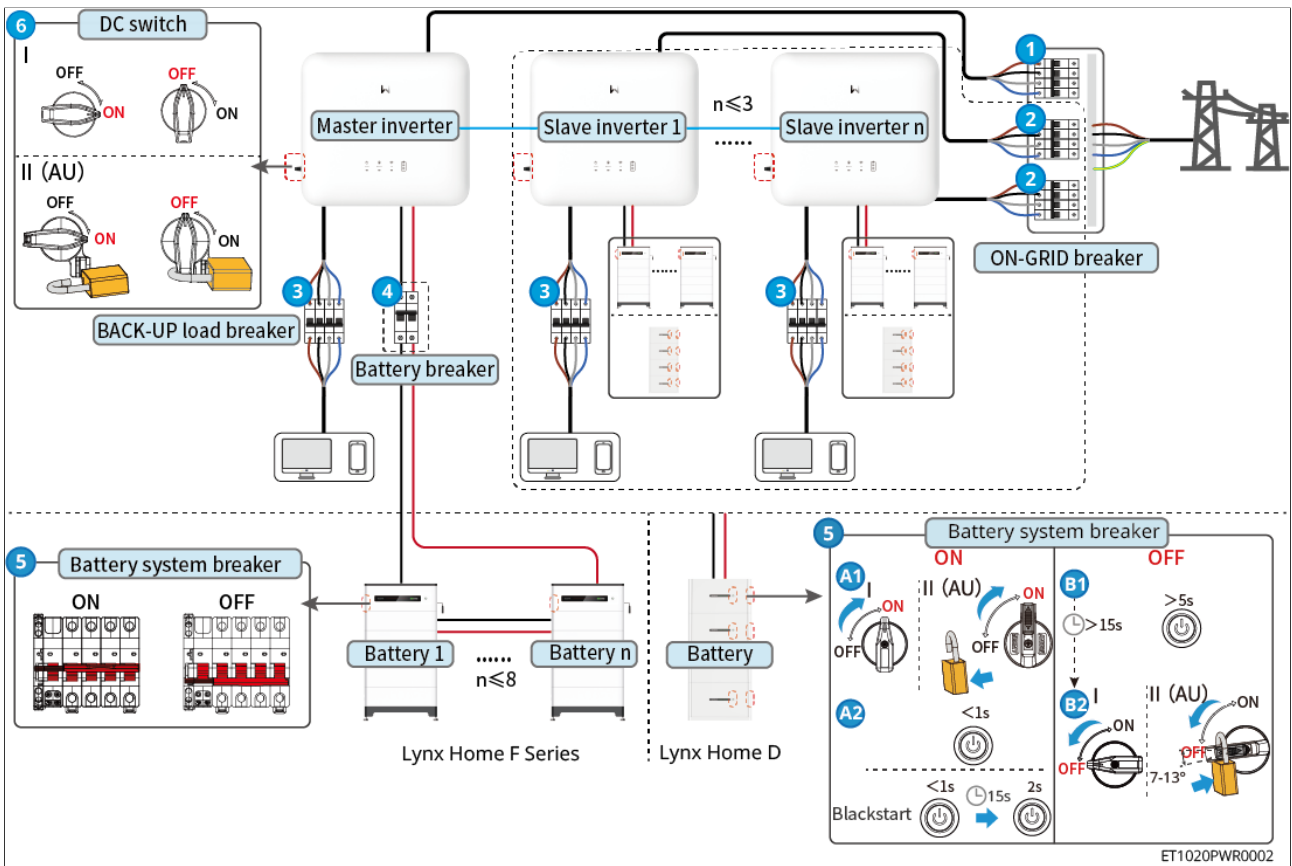







Figure59 Power ON













Power ON/OFF steps: ① → ② → ③ → ④ → ⑤ → ⑥

④ : Optional based on local laws and regulations.

6.3 Indicators

6.3.1 Inverter Indicators

Indicator	Status	Description
		The inverter is powered on and in standby mode.
		The inverter is starting up and in self-test mode.
		The inverter is operating normally in grid-tied power generation or off-grid mode.
		BACK-UP output overload.

Indicator	Status	Description
		System fault.
		The inverter is powered off.
		Grid abnormal, inverter BACK-UP port power supply normal.
		Grid normal, inverter BACK-UP port power supply normal.
		No power supply at the BACK-UP port.
		Inverter monitoring module is resetting.
		No connection established between the inverter and the communication terminal.
		Communication fault between the communication terminal and the cloud server.
		Inverter monitoring is normal.
		Inverter monitoring module is not started.

6.3.2 Battery Indicators

6.3.2.1 Lynx Home F Series





SOC Indicator

Button Indicator

LXU10CON0001

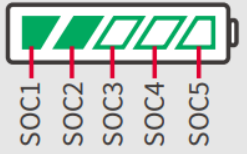
Normal Status

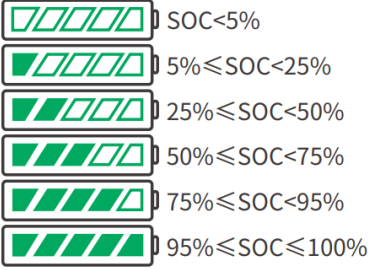







<p>SOC indicator</p> 	<p>Button indicator</p> 	<p>Battery system status</p>
<p>SOC indicator indicates the battery system's charge level</p> 	<p>Green flashes 1 time /s</p> <p>Green flashes 2 times /s</p> <p>Green steady on</p>	<p>Battery system is in standby state</p> <p>Battery system is in idle state</p> <p>Battery system is in charging state</p> <p>Note: When the battery SOC reaches the charging cutoff SOC, charging will stop.</p>
<p>SOC indicator flashes 1 time /s</p> <ul style="list-style-type: none"> • When $5\% \leq \text{SOC} < 25\%$, SOC1 flashes • When $25\% \leq \text{SOC} < 50\%$, SOC2 flashes • When $50\% \leq \text{SOC} < 75\%$, SOC3 flashes • When $75\% \leq \text{SOC} < 95\%$, SOC4 flashes • When $95\% \leq \text{SOC} \leq 100\%$, SOC5 flashes 	<p>Green steady on</p>	<p>Battery system is in discharging state</p> <p>Note: When there is no need to supply power to the load in the system or the battery SOC is below the set depth of discharge, the battery will no longer discharge.</p>

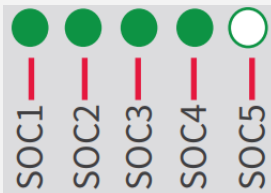

Abnormal Status

Button Indicator Light 	Battery System Status	Description
Red flashes 1 time/s	Battery system alarm triggered	After a battery system alarm is triggered, the system will perform a self-test. Wait for the self-test to complete; the battery system will then enter normal operation or a fault state.
Red steady on	Battery system fault occurred	Determine the fault type based on the display pattern of the SOC indicator light, and handle it according to the methods recommended in the fault handling section.

6.3.2.2 Lynx Home D

Normal Status

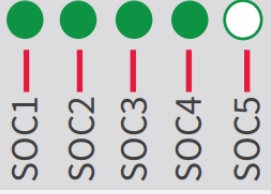
SOC indicator 	Button indicator 	Battery system status
SOC indicator shows the battery system's charge level  SOC < 5%  5% ≤ SOC < 25%  25% ≤ SOC < 50%  50% ≤ SOC < 75%  75% ≤ SOC < 95%  95% ≤ SOC ≤ 100%	Green flashing	Battery system is in standby mode
	Green solid	Battery system is in charging state Note: Battery charging will stop when the battery SOC reaches the charge cutoff SOC.

SOC indicator  SOC1 SOC2 SOC3 SOC4 SOC5	Button indicator 	Battery system status
<p>Highest SOC indicator flashes at 1 time/s</p> <ul style="list-style-type: none"> • When 5%≤SOC<25%, SOC1 flashes • When 25%≤SOC<50%, SOC2 flashes • When 50%≤SOC<75%, SOC3 flashes • When 75%≤SOC<95%, SOC4 flashes • When 95%≤SOC≤100%, SOC5 flashes 	<p>Green solid</p>	<p>Battery system is in discharge state</p> <p>Note: The battery will stop discharging when there is no need to supply power to the load in the system or when the battery SOC is below the set depth of discharge.</p>



Abnormal Status

Button Indicator Light 	Battery System Status	Description
<p>Red Blinking</p>	<p>Battery System Alarm Occurred</p>	<p>After an alarm occurs in the battery system, the system will perform a self-check. Wait for the self-check to complete, after which the battery system will enter normal operation status or fault status. You can view alarm information via the SolarGo APP.</p>





Button Indicator Light 	Battery System Status	Description
Red Steady On	Battery System Fault Occurred	You can determine the type of fault that occurred by combining it with the display pattern of the SOC indicator light, or view fault information via the SolarGo APP, and handle it according to the methods recommended in the fault handling section.

6.3.3 Smart Meter Indicator

GM3000

Type	Status	Description
Power light 	Steady on	The meter is powered on.
	Off	The meter is powered off.
Buy/Sell light 	Steady on	buy power from the grid
	Flashing	Selling power to the grid
Communication light 	Flashing	Normal communication
	Flashing 5 times consecutively	<ul style="list-style-type: none"> Press the Reset button for <3s: Meter reset Press the Reset button for 5s: Meter parameters restored to factory defaults Press the Reset button for >10s: Meter parameters restored to factory defaults, and energy data cleared
	Off	No communication from the meter

GM330





Type	Status	Description
Power Indicator 	Steady On	The meter is powered on, with no RS485 communication
	Blinking	The meter is powered on, RS485 communication is normal
	Off	The meter is powered off
Communication Indicator 	Off	Reserved
	Blinking	Press and hold the Reset button for $\geq 5s$, the Power and Buy/Sell indicators blink: Meter reset
Buy/Sell Indicator 	Steady On	buy power from the grid
	Blinking	Selling power to the grid
	Off	Not buying or selling power
	Reserved	







6.3.4 Smart Dongle Indicator

- WiFi/LAN Kit-20

NOTICE

- After double-clicking the Reload button to turn on Bluetooth, the communication indicator light will switch to a single-blink state. Please connect to the SolarGo APP within 5 minutes, otherwise Bluetooth will automatically turn off.
- The single-blink state of the communication indicator light only occurs after double-clicking the Reload button to turn on Bluetooth.





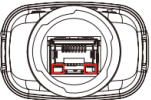



Indicator or	Status	Description
Power Light 		Steady on: The Smart Communication Stick is powered on.
		Off: The Smart Communication Stick is not powered on.
		Steady on: WiFi mode or LAN mode communication is normal.

Indicator	Status	Description
Communication Light 		Single blink: The Smart Communication Stick's Bluetooth signal is on, waiting to connect to the SolarGo app.
		Two blinks: The Smart Communication Stick failed to connect to the router.
		Four blinks: The Smart Communication Stick communicates normally with the router but failed to connect to the server.
		Six blinks: The Smart Communication Stick is identifying connected devices.
		Off: The Smart Communication Stick is undergoing a software reset or is not powered on.

indicator	Color	Status	Description
LAN Port Communication Indicator 	Green	Steady on	100Mbps wired network connection is normal.
		Off	<ul style="list-style-type: none"> • Network cable is not connected. • 100Mbps wired network connection is abnormal. • 10Mbps wired network connection is normal.
	Yellow	Steady on	10/100Mbps wired network connection is normal, with no communication data transmission.
		Flashing	Communication data is being transmitted and received.
		Off	Network cable is not connected.



Button	Description
Reload	Hold for 0.5~3 seconds to reset the Smart Communication Bar.
	Hold for 6~20 seconds to restore the Smart Communication Bar to factory settings.
	Double-click quickly to enable the Bluetooth signal (maintained for only 5 minutes).

- 4G Kit-CN-G20 & 4G Kit-CN-G21

Indicator	Status	Description
		Steady on: The smart communication stick is powered on.
		Off: The smart communication stick is not powered on.
		Steady on: The smart communication stick is connected to the server, communication is normal.
		Double flash: The smart communication stick is not connected to the communication base station.
		Quadruple flash: The smart communication stick is connected to the communication base station, but not connected to the server.
		Sextuple flash: Communication between the smart communication stick and the inverter is disconnected.
		Off: The smart communication stick is undergoing a software reset or is not powered on.







Button	Description
RELOAD	Hold for 0.5~3 seconds, the Smart Communication Stick will restart.
	Hold for 6~20 seconds, the Smart Communication Stick will restore factory settings.

• **LS4G Kit-CN、4G Kit-CN**

indicator	color	status	description
Power indicator 	green	on	module is secured and powered on
		off	module is not secured or not powered on
Communi cation indicator 	blue	slow blinking (0.2 on, 1.8s off)	<ul style="list-style-type: none"> • inverter communication indicator 2 flashes: dialing, searching for network • inverter communication indicator 4 flashes: no traffic causing cloud connection failure

	slow blinking (1.8s on, 0.2s off)	<ul style="list-style-type: none"> • inverter communication indicator 2 flashes: dialing successful • inverter communication indicator steady on: cloud connection successful • inverter communication indicator 4 flashes: no traffic causing cloud connection failure
	fast blinking (0.125s on, 0.125s off)	inverter is communicating with the cloud via the module
	0.2s on, 8s off	SIM card not installed or SIM card poor contact

• **Ezlink3000**

indicator/Silkscreen	Color	Status	Description
Power light 	Blue		Flashing: The communication stick is operating normally.
			Off: The communication stick is powered off.
Communication light 	Green		Steady on: The communication stick is connected to the server.
			Double flash: The communication stick is not connected to the router.
			Quadruple flash: The communication stick is connected to the router, but not connected to the server.
RELOAD	-	-	Short press for 1-3 seconds to restart the communication stick. Long press for 6-10 seconds to restore factory settings. Double-click quickly to enable Bluetooth signal (maintained for 5 minutes only).

7 System Debugging and Power Station Monitoring

7.1 Device Commissioning and Power Plant Monitoring via the SEMS+ App

The SEMS+ App is a software for remote power plant monitoring or local device commissioning. It supports installers or owners to:

- Remotely monitor the power plant operation and set the operating parameters for the power plant and devices.
- Locally connect to devices to view their operation status and set device parameters.

Download and Install the SEMS+ App

Mobile Phone Requirements:

- Operating system requirements: Android 7.0 or above, iOS 15.1 or above.
- The phone must support a web browser and have an Internet connection.
- The phone must support WLAN/Bluetooth functionality.

Download Methods:

Method 1:

Search for "SEMS+" in Google Play, the App Store, Huawei, Honor, Xiaomi, OPPO, or vivo app stores to download and install it.



Method 2:

Scan the QR code below to download and install it.

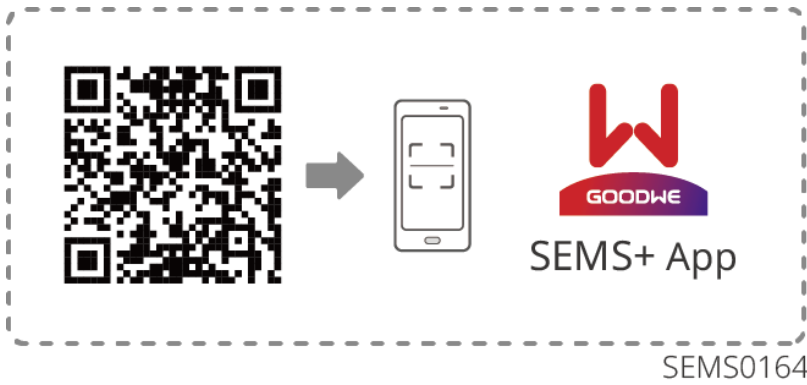

For detailed functions, please refer to the [SEMS+ App User Manual](#). The user manual can be obtained from the official website or by scanning the QR code below.



7.2 Device Commissioning and Plant Monitoring via SEMS+ WEB

SEMS+ WEB is a monitoring platform that communicates via WiFi or LAN. The common functions of SEMS+ WEB are as follows:

1. Manage organization or user information, etc.
2. Add and monitor plant information, etc.
3. Maintain devices.

For detailed functions, please refer to the [SEMS+ WEB User Manual](#).



SEMS+ WEB User Manual

8 Maintenance

8.1 Power OFF the System

DANGER

- When performing operation and maintenance on equipment within the system, please power down the system. Operating equipment with power on may lead to equipment damage or risk of electric shock.
- After the equipment is powered off, internal components require a certain amount of time to discharge. Please wait according to the time specified on the label until the equipment is completely discharged.
- Restarting the battery should be performed using the air switch power-on method.
- When shutting down the battery system, please strictly adhere to the battery system power-off requirements to prevent damage to the battery system.
- When there are multiple batteries in the system, powering off any one battery can power down all batteries.

NOTICE

- The circuit breakers between the inverter and the battery, and between battery systems, must be installed in accordance with local laws and regulations.
- To ensure effective protection of the battery system, keep the cover plate of the battery system switch closed; the protective cover should automatically close after being opened. If the battery system switch will not be used for an extended period, secure it with screws.

Power OFF Procedure

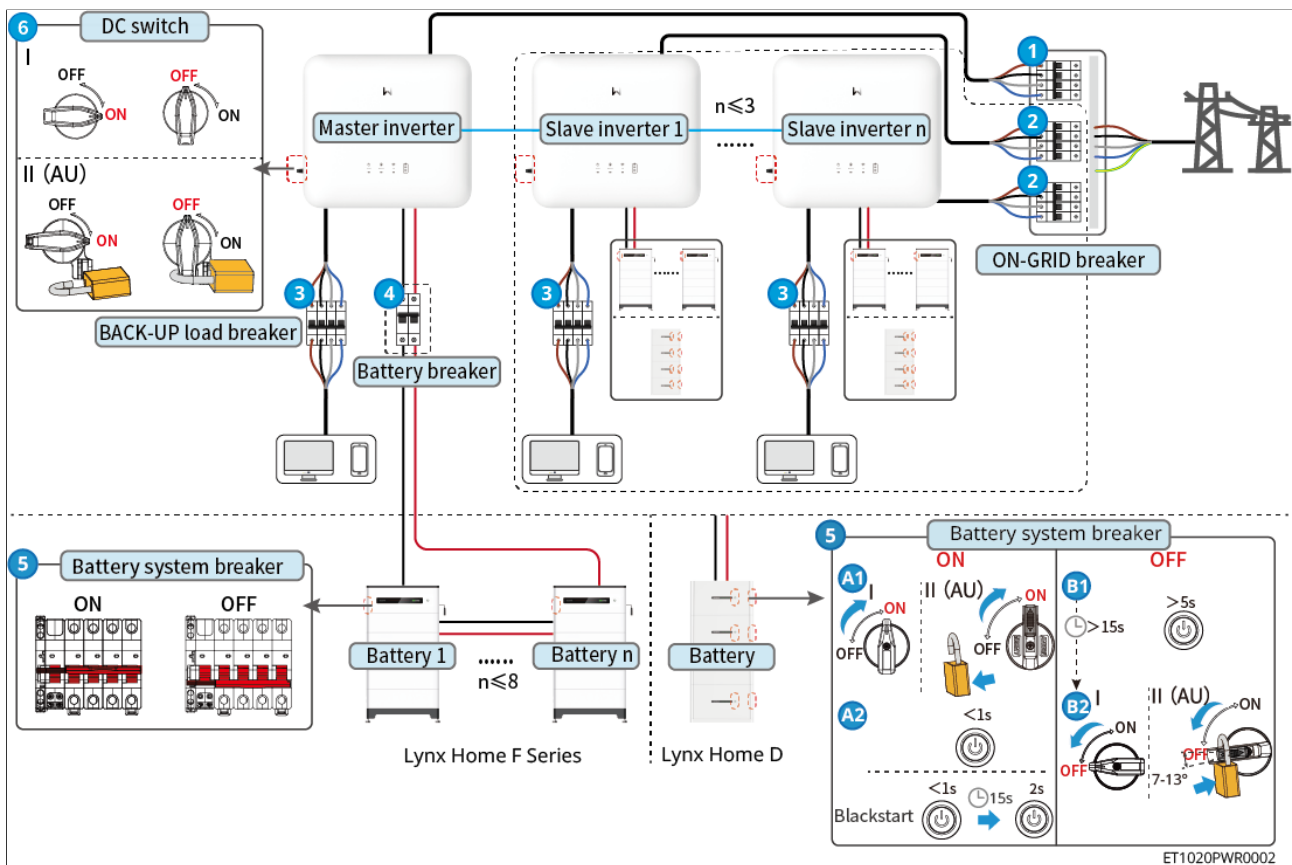

Figure60

Power ON/OFF Steps: ① → ② → ③ → ④ → ⑤ → ⑥

④ : Optional based on local laws and regulations.

8.2 Removing the Equipment



- Ensure the device is powered off.
- When operating the device, please wear personal protective equipment.
- When removing wiring terminals, use standard disassembly tools to avoid damaging the terminals or the device.
- Unless otherwise specified, the device disassembly method is the reverse order of the installation method, and this document will not elaborate further.

1. Power down the system.
2. Label the cables connected in the system to indicate their type.
3. Disconnect the cables in the system for the Inverter, Battery, and smart meter, such as: DC cables, AC cables, Communication cable, and PE cable.
4. Remove equipment such as the smart communication stick, Inverter, Battery, and smart meter.
5. Store the equipment properly. If it will be put into use again later, ensure the storage conditions meet the requirements.

8.3 Disposing of the Equipment

When the equipment can no longer be used and needs to be disposed of, please dispose of it according to the electrical waste disposal regulations of the country/region where the equipment is located. Do not dispose of the equipment as household waste.

8.4 Routine Maintenance

WARNING

- If any issue that may affect the battery or energy storage inverter system is found, contact after-sales personnel. Disassembly by unauthorized personnel is prohibited.
- If exposed copper wires are found inside the conductive cable, do not touch them. High voltage hazard. Contact after-sales personnel. Disassembly by unauthorized personnel is prohibited.
- In case of any other emergencies, contact after-sales personnel immediately. Operate under their guidance or wait for them to perform on-site operations.

Maintenance Content	Maintenance Method	Maintenance Cycle	Maintenance Purpose
System Cleaning	Check for foreign objects or dust on heat sinks, fans, and air inlets/outlets. Check if the installation space meets requirements, and check for debris accumulation around the equipment.	Once every six months	Prevent cooling failures.
System Installation	Check if the equipment installation is secure and if fastening screws are loose. Check for any damage or deformation on the equipment exterior.	Once every six months to once a year	Confirm equipment installation stability.
Electrical Connections	Check for loose electrical connections, damaged cable sheathing, or exposed copper wires.	Once every six months to once a year	Confirm electrical connection reliability.
Sealing	Check if the sealing of equipment cable entry holes meets requirements. If gaps are too large or unsealed, reseal them.	Once a year	Confirm machine sealing and intact waterproof performance.
Battery Maintenance	If the battery has been unused or not fully charged for an extended period, periodic charging is recommended.	Once every 15 days	Protect battery service life.

8.5 fault

8.5.1 Viewing Fault/Alarms Information

All detailed fault and alarm information for the energy storage system is displayed in the [SolarGo APP], [SEMS+ App], and [SEMS+ WEB]. If your product is abnormal and you do not see related fault information in the [SolarGo APP], [SEMS+ App], or [SEMS+ WEB], please contact the after-sales service center.

- SolarGo APP

View the energy storage system alarm information via [Home] > [Parameters] > [Alarms].

- SEMS+ App

1. Open the SEMS+ App and log in with any account.
2. View all power station fault information via [power station] > [Alarms].
3. Click on a specific fault name to view details such as the time of occurrence, possible causes, and solutions.

SEMS+ WEB

- Open SEMS+ WEB and log in with any account.
- On the power station details interface, click [Alarms] to view all alarm information for the current power station.

8.5.2 Fault Information and Troubleshooting

Please perform troubleshooting according to the following methods. If the troubleshooting methods do not help you, please contact the after-sales service center.

When contacting the after-sales service center, please collect the following information to facilitate a quick resolution.

1. Product information, such as: serial number, software version, device installation time, fault occurrence time, fault frequency, etc.
2. Device installation environment, such as: weather conditions, whether components are obstructed, have shadows, etc. For the installation environment, providing photos, videos, and other files is recommended to assist in problem analysis.
3. Grid conditions.

8.5.2.1 System Failure

If the system experiences an unlisted problem, or if following the instructions still cannot prevent the issue or abnormality, immediately stop system operation and contact your dealer at once.

No.	fault	Resolution
1	Unable to search for the Smart Communication Stick's wireless signal	<ol style="list-style-type: none"> 1. Ensure no other device is connected to the Smart Communication Stick's wireless signal. 2. Ensure the App is upgraded to the latest version. 3. Ensure the Smart Communication Stick is powered normally, with the blue signal light blinking or steady on. 4. Ensure the smart device is within the communication range of the Smart Communication Stick. 5. Refresh the App's device list again. 6. Restart the inverter.
2	Unable to connect to the Smart Communication Stick's wireless signal	<ol style="list-style-type: none"> 1. Ensure no other device is connected to the Smart Communication Stick's wireless signal. 2. Restart the inverter or the Communication Stick, then try connecting to the Smart Communication Stick's wireless signal again. 3. Ensure Bluetooth encryption pairing is successful.
3	Unable to find the router SSID	<ol style="list-style-type: none"> 1. Place the router closer to the Smart Communication Stick, or add a WiFi repeater to enhance the WiFi signal. 2. Reduce the number of devices connected to the router.
4	After all configurations are complete, the Smart Communication Stick fails to connect to the router	<ol style="list-style-type: none"> 1. Restart the inverter. 2. Check if the network name, encryption method, and password in the WiFi configuration are the same as those of the router. 3. Restart the router. 4. Place the router closer to the Smart Communication Stick, or add a WiFi repeater to enhance the WiFi signal.

No.	fault	Resolution
5	After all configurations are complete, the Smart Communication Stick fails to connect to the server	Restart the router and the inverter.

8.5.2.2 Inverter Fault

8.5.2.2.1 Troubleshooting (Fault Codes F01-F40)

Fault Code	Fault Name	Fault Cause	Recommended Troubleshooting
F01	Grid Power Outage	<ol style="list-style-type: none"> 1. Grid power outage. 2. AC line or AC switch is disconnected. 	<ol style="list-style-type: none"> 1. The alarm will disappear automatically after grid power is restored. 2. Check if the AC line or AC switch is disconnected.

Fault Code	Fault Name	Fault Cause	Recommended Troubleshooting
F02	Grid Overvoltage Protection	Grid voltage is higher than the allowable range, or the duration of high voltage exceeds the high voltage ride-through setting.	<ol style="list-style-type: none"> 1. If it occurs occasionally, it may be due to a short-term grid anomaly. The inverter will resume normal operation after detecting a normal grid, requiring no manual intervention. 2. If it occurs frequently, check if the grid voltage is within the allowable range. If not, contact the local power operator. If it is, you also need to modify the grid overvoltage protection point after obtaining consent from the local power operator. 3. If it cannot be restored for a long time, check if the AC side circuit breaker and output cables are properly connected.

Fault Code	Fault Name	Fault Cause	Recommended Troubleshooting
F03	Grid Undervoltage Protection	Grid voltage is lower than the allowable range, or the duration of low voltage exceeds the low voltage ride-through setting.	<ol style="list-style-type: none"> 1. If it occurs occasionally, it may be due to a short-term grid anomaly. The inverter will resume normal operation after detecting a normal grid, requiring no manual intervention. 2. If it occurs frequently, check if the grid voltage is within the allowable range. If not, contact the local power operator. If it is, you also need to modify the grid undervoltage protection point after obtaining consent from the local power operator. 3. If it cannot be restored for a long time, check if the AC side circuit breaker and output cables are properly connected.

Fault Code	Fault Name	Fault Cause	Recommended Troubleshooting
F04	Grid Rapid Overvoltage Protection	Abnormal grid voltage detection or ultra-high voltage triggers the fault.	<p>1. If it occurs occasionally, it may be due to a short-term grid anomaly. The inverter will resume normal operation after detecting a normal grid, requiring no manual intervention.</p> <p>2. If it occurs frequently, check if the grid voltage is within the allowable range. If not, contact the local power operator. If it is, you also need to modify the grid undervoltage protection point after obtaining consent from the local power operator.</p> <p>3. If it cannot be restored for a long time, check if the AC side circuit breaker and output cables are properly connected.</p>
F05	10min Overvoltage Protection	The moving average of grid voltage exceeds the safety regulation range within 10min.	Check if the grid voltage is operating at a high voltage for a long period. If it occurs frequently, check if the grid frequency is within the allowable range. If not, contact the local power operator. If it is, you also need to modify the grid 10min overvoltage protection point after obtaining consent from the local power operator.

Fault Code	Fault Name	Fault Cause	Recommended Troubleshooting
F06	Grid Overfrequency	Grid anomaly: The actual grid frequency is higher than the local grid standard requirements.	<p>1. If it occurs occasionally, it may be due to a short-term grid anomaly. The inverter will resume normal operation after detecting a normal grid, requiring no manual intervention.</p> <p>2. If it occurs frequently, check if the grid frequency is within the allowable range. If not, contact the local power operator. If it is, you also need to modify the grid overfrequency protection point after obtaining consent from the local power operator.</p>
F07	Grid Underfrequency	Grid anomaly: The actual grid frequency is lower than the local grid standard requirements.	<p>1. If it occurs occasionally, it may be due to a short-term grid anomaly. The inverter will resume normal operation after detecting a normal grid, requiring no manual intervention.</p> <p>2. If it occurs frequently, check if the grid frequency is within the allowable range. If not, contact the local power operator. If it is, you also need to modify the grid overfrequency protection point after obtaining consent from the local power operator.</p>

Fault Code	Fault Name	Fault Cause	Recommended Troubleshooting
F08	Grid Frequency Instability	Grid anomaly: The rate of change of the actual grid frequency does not comply with the local grid standard.	<p>1. If it occurs occasionally, it may be due to a short-term grid anomaly. The inverter will resume normal operation after detecting a normal grid, requiring no manual intervention.</p> <p>2. If it occurs frequently, check if the grid frequency is within the allowable range. If not, contact the local power operator.</p>
F09	Anti-islanding Protection	The grid has been disconnected, but grid voltage is maintained due to the presence of loads. Grid connection is stopped according to safety protection requirements.	<p>1. If it occurs occasionally, it may be due to a short-term grid anomaly. The inverter will resume normal operation after detecting a normal grid, requiring no manual intervention.</p> <p>2. If it occurs frequently, check if the grid frequency is within the allowable range. If not, contact the local power operator.</p>
F10	LVRT Undervoltage	Grid anomaly: The duration of abnormal grid voltage exceeds the time specified by the high/low voltage ride-through.	<p>1. If it occurs occasionally, it may be due to a short-term grid anomaly. The inverter will resume normal operation after detecting a normal grid, requiring no manual intervention.</p> <p>2. If it occurs frequently, check if the grid voltage and frequency are within the allowable range and stable. If not, contact the local power operator.</p>

Fault Code	Fault Name	Fault Cause	Recommended Troubleshooting
F11	HVRT Overvoltage	Grid anomaly: The duration of abnormal grid voltage exceeds the time specified by the high/low voltage ride-through.	<p>1. If it occurs occasionally, it may be due to a short-term grid anomaly. The inverter will resume normal operation after detecting a normal grid, requiring no manual intervention.</p> <p>2. If it occurs frequently, check if the grid voltage and frequency are within the allowable range and stable. If not, contact the local power operator.</p>
F12	30mA GFCI Protection	The input-to-ground insulation impedance becomes low during inverter operation.	<p>1. If it occurs occasionally, it may be caused by occasional external line anomalies. It will resume normal operation after the fault is cleared, requiring no manual intervention.</p> <p>2. If it occurs frequently or cannot be restored for a long time, check if the PV string's ground impedance is too low.</p>
F13	60mA GFCI Protection	The input-to-ground insulation impedance becomes low during inverter operation.	<p>1. If it occurs occasionally, it may be caused by occasional external line anomalies. It will resume normal operation after the fault is cleared, requiring no manual intervention.</p> <p>2. If it occurs frequently or cannot be restored for a long time, check if the PV string's ground impedance is too low.</p>

Fault Code	Fault Name	Fault Cause	Recommended Troubleshooting
F14	150mA GFCI Protection	The input-to-ground insulation impedance becomes low during inverter operation.	<p>1. If it occurs occasionally, it may be caused by occasional external line anomalies. It will resume normal operation after the fault is cleared, requiring no manual intervention.</p> <p>2. If it occurs frequently or cannot be restored for a long time, check if the PV string's ground impedance is too low.</p>
F15	GFCI Gradual Change Protection	The input-to-ground insulation impedance becomes low during inverter operation.	<p>1. If it occurs occasionally, it may be caused by occasional external line anomalies. It will resume normal operation after the fault is cleared, requiring no manual intervention.</p> <p>2. If it occurs frequently or cannot be restored for a long time, check if the PV string's ground impedance is too low.</p>
F16	DCI Level 1 Protection	The DC component of the inverter output current exceeds the safety regulations or the default allowable range of the machine.	<p>1. If the abnormality is caused by an external fault, the inverter will automatically resume normal operation after the fault disappears, requiring no manual intervention.</p> <p>2. If this alarm occurs frequently, affecting the normal power generation of the power station, please contact the dealer or after-sales service center.</p>

Fault Code	Fault Name	Fault Cause	Recommended Troubleshooting
F17	DCI Level 2 Protection	The DC component of the inverter output current exceeds the safety regulations or the default allowable range of the machine.	<ol style="list-style-type: none"> 1. If the abnormality is caused by an external fault, the inverter will automatically resume normal operation after the fault disappears, requiring no manual intervention. 2. If this alarm occurs frequently, affecting the normal power generation of the power station, please contact the dealer or after-sales service center.

Fault Code	Fault Name	Fault Cause	Recommended Troubleshooting
F18	Low Insulation Resistance	<ol style="list-style-type: none"> 1. Photovoltaic string short-circuited to protective ground. 2. The photovoltaic string is installed in a long-term humid environment with poor line-to-ground insulation. 3. Low insulation resistance of the battery port line to ground. 	<ol style="list-style-type: none"> 1. Check the impedance of the photovoltaic string/battery port to the protective ground. A resistance value greater than 80kΩ is normal. If the measured resistance is less than 80kΩ, please locate and rectify the short circuit point. 2. Check if the inverter's protective ground wire is correctly connected. 3. If it is confirmed that the impedance is indeed below the default value in rainy weather conditions, please reset the inverter's "Insulation Resistance Protection Point" via the App. <p>For inverters in the Australian and New Zealand markets, the following additional alarm methods are available when an insulation resistance fault occurs:</p> <ol style="list-style-type: none"> 1. The inverter is equipped with a buzzer. When a fault occurs, the buzzer sounds continuously for 1 minute; if the fault is not resolved, the buzzer will sound again every 30 minutes. 2. If the inverter is added to the monitoring platform and the alarm notification method is set, alarm information can be sent to customers via email.

Fault Code	Fault Name	Fault Cause	Recommended Troubleshooting
F19	Grounding Abnormal	<p>1. The protective ground wire of the inverter is not connected.</p> <p>2. When the output of the photovoltaic string is grounded, the inverter output side is not connected to an isolation transformer.</p>	<p>1. Please confirm whether the inverter's protective ground wire is properly connected.</p> <p>2. In scenarios where the output of the photovoltaic string is grounded, please confirm whether an isolation transformer is connected to the inverter output side.</p>
F20	Hard Anti-Islanding Protection	Load abnormal fluctuation	<p>1. If the abnormality is caused by an external fault, the inverter will automatically resume normal operation after the fault disappears, requiring no manual intervention.</p> <p>2. If this alarm occurs frequently, affecting the normal power generation of the power station, please contact the dealer or after-sales service center.</p>

Fault Code	Fault Name	Fault Cause	Recommended Troubleshooting
F21	Internal Comm Loss	Slave DSP1 communication timeout - Master DSP, Slave DSP2 communication timeout - Master DSP, Slave DSP2 communication timeout - Slave DSP1, Master DSP communication timeout - Slave DSP1, Master DSP communication timeout - Slave DSP2, or Slave DSP1 communication timeout - Slave DSP2: 1. Chip not powered on 2. Chip program version error	Turn off the AC output side switch and the DC input side switch, wait for 5 minutes, then turn on the AC output side switch and the DC input side switch. If the fault persists, please contact the dealer or after-sales service center.

Fault Code	Fault Name	Fault Cause	Recommended Troubleshooting
		Master DSP can module error, Slave DSP1 can module error, or Slave DSP2 can module error: 1. Frame format error 2. Parity check error 3. can bus offline 4. Hardware CRC check error 5. Control bit is set to receive (transmit) during transmission (reception) 6. Transmission to a disallowed unit	
F22	Generator Waveform Detection Fault	1. This fault will be displayed continuously if no generator is connected. 2. When the generator is operating, this fault will be triggered if it does not meet the generator safety regulations.	
F23	Generator Abnormal Connection		
F24	Generator Voltage Low		
F25	Generator Voltage High		
F26	Generator Frequency Low		

Fault Code	Fault Name	Fault Cause	Recommended Troubleshooting
F27	Generator Frequency High		<ol style="list-style-type: none"> 1. Ignore this fault if no generator is connected. 2. If this fault occurs when the generator malfunctions, it is normal. Wait for a period after the generator recovers, and the fault will clear automatically. 3. This fault does not affect the normal operation of the off-grid mode. 4. If both the generator and the grid are connected and meet safety regulations, the grid has priority for grid connection, and the system will operate in grid-connected mode.
F28	Parallel Unit I/O Self-Test Abnormal	Parallel communication cable not securely connected or parallel unit IO chip damaged	Check if the parallel communication cable is securely connected, then check if the IO chip is damaged. If so, replace the IO chip.
F29	Parallel Grid Line Reversed	Grid lines of some units are reversed with others	Reconnect the grid lines.
F30	AC HCT check Abnormal	Abnormal sampling detected in the AC sensor	Turn off the AC output side switch and the DC input side switch, wait for 5 minutes, then turn them back on. If the fault persists, please contact the dealer or the after-sales service center.

Fault Code	Fault Name	Fault Cause	Recommended Troubleshooting
F31	GFCI HCT Check Abnormal	Abnormal sampling detected in the leakage current sensor	Turn off the AC output side switch and the DC input side switch, wait for 5 minutes, then turn them back on. If the fault persists, please contact the dealer or the after-sales service center.
F32	Inverter Internal Failure	A fault is detected in the inverter	Turn off the AC output side switch and the DC input side switch, wait for 5 minutes, then turn them back on. If the fault persists, please contact the dealer or the after-sales service center.
F33	Flash Read/Write Error	Possible causes: Flash content has changed; Flash lifespan exhausted;	1. Upgrade to the latest firmware. 2. Contact the dealer or the after-sales service center.
F34	AFCI Check Failure	The arc fault detection module did not detect an arc fault during the self-check process	Turn off the AC output side switch and the DC input side switch, wait for 5 minutes, then turn them back on. If the fault persists, please contact the dealer or the after-sales service center.

Fault Code	Fault Name	Fault Cause	Recommended Troubleshooting
F35	Cabinet Overtemperature	Cabinet temperature is too high. Possible causes: 1. The inverter installation location has poor ventilation. 2. Ambient temperature is too high. 3. Internal fan operation is abnormal.	1. Check if the ventilation at the inverter installation location is adequate and if the ambient temperature exceeds the maximum allowable range. 2. If ventilation is poor or ambient temperature is too high, improve the ventilation and heat dissipation conditions. 3. If both ventilation and ambient temperature are normal, please contact the dealer or the after-sales service center.

Fault Code	Fault Name	Fault Cause	Recommended Troubleshooting
F36	Bus Overvoltage	BUS overvoltage. Possible causes: 1. PV voltage is too high; 2. Inverter BUS voltage sampling is abnormal; 3. Poor isolation effect of the dual-split transformer at the inverter's output, causing mutual interference when two inverters are connected in parallel, leading to DC overvoltage alarm for one inverter during grid connection;	Turn off the AC output side switch and the DC input side switch, wait for 5 minutes, then turn them back on. If the fault persists, please contact the dealer or the after-sales service center.

Fault Code	Fault Name	Fault Cause	Recommended Troubleshooting
F37	PV Input Overvoltage	<p>PV input voltage is too high. Possible cause: Incorrect photovoltaic array configuration. Too many solar panels are connected in series in a string, causing the string's open-circuit voltage to exceed the inverter's maximum operating voltage.</p>	<p>Check the series configuration of the corresponding photovoltaic array string to ensure the string's open-circuit voltage does not exceed the inverter's maximum operating voltage. The inverter alarm will automatically clear once the photovoltaic array is configured correctly.</p>
F38	PV Sustained Hardware Overcurrent	<ol style="list-style-type: none"> 1. Unreasonable module configuration 2. Hardware damage 	<p>Turn off the AC output side switch and the DC input side switch, wait for 5 minutes, then turn them back on. If the fault persists, please contact the dealer or the after-sales service center.</p>
F39	PV Sustained Software Overcurrent	<ol style="list-style-type: none"> 1. Unreasonable module configuration 2. Hardware damage 	<p>Turn off the AC output side switch and the DC input side switch, wait for 5 minutes, then turn them back on. If the fault persists, please contact the dealer or the after-sales service center.</p>

Fault Code	Fault Name	Fault Cause	Recommended Troubleshooting
F40, F98	String Reverse Connection (String 1-n) n: Determined based on the actual number of inverter strings	PV string reverse connection	Check if the string is connected in reverse.

8.5.2.2.2 Troubleshooting (Fault Codes F41-F80)

Fault Code	Fault Name	Fault Cause	Troubleshooting Recommendation
F41	Generator Port Overload	<ol style="list-style-type: none"> 1. Off-grid side output exceeds specifications. 2. Off-grid side short circuit. 3. Off-grid terminal voltage is too low. 4. When used as a heavy load port, the heavy load exceeds specifications. 	Confirm the cause of the problem by checking data such as off-grid side output voltage, current, and power.

Fault Code	Fault Name	Fault Cause	Troubleshooting Recommendation
F42	DC Arcing Failure (String 1-n) n: Determined by the actual number of inverter strings.	<ol style="list-style-type: none"> 1. DC side connection terminals are loose. 2. DC side connection terminals have poor contact. 3. DC cable cores are damaged, causing poor contact. 	<ol style="list-style-type: none"> 1. After the machine reconnects to the grid, check if the voltage and current of each string abnormally decrease or become zero. 2. Check if the DC side terminals are securely connected.
F43	Grid Waveform Abnormal	Utility grid abnormality: Grid voltage detection anomaly triggers the fault.	<ol style="list-style-type: none"> 1. If it occurs occasionally, it may be due to a temporary grid abnormality. The inverter will resume normal operation after detecting a normal grid, requiring no manual intervention. 2. If it occurs frequently, please check if the grid voltage and frequency are within the allowable range and stable. If not, contact the local power operator.
F44	Grid Phase Loss	Utility grid abnormality: Single-phase voltage drop in the grid.	<ol style="list-style-type: none"> 1. If it occurs occasionally, it may be due to a temporary grid abnormality. The inverter will resume normal operation after detecting a normal grid, requiring no manual intervention. 2. If it occurs frequently, please check if the grid voltage and frequency are within the allowable range and stable. If not, contact the local power operator.

Fault Code	Fault Name	Fault Cause	Troubleshooting Recommendation
F45	Grid Voltage Imbalance	Excessive difference in grid phase voltages.	<p>1. If it occurs occasionally, it may be due to a temporary grid abnormality. The inverter will resume normal operation after detecting a normal grid, requiring no manual intervention.</p> <p>2. If it occurs frequently, please check if the grid voltage and frequency are within the allowable range and stable. If not, contact the local power operator.</p>
F46	Grid Phase Sequence Failure	Inverter and grid wiring abnormality: Wiring is not in positive sequence.	<p>1. Check if the inverter and grid wiring are in positive sequence. The fault will disappear automatically after correct wiring (e.g., swapping any two live wires).</p> <p>2. If the fault persists despite correct wiring, contact the dealer or after-sales service center.</p>
F47	Grid Rapid Shutdown Protection	Quickly shuts down output after detecting a grid power outage condition.	The fault disappears automatically after grid power supply is restored.
F48	Grid Neutral Wire Loss (Split Grid)	Loss of neutral wire in split-phase grid.	<p>1. The alarm disappears automatically after grid power supply is restored.</p> <p>2. Check if the AC line or AC switch is disconnected.</p>
F49	L-PE Short Circuit	Output phase line has low impedance or short circuit to PE.	Measure the impedance between the output phase line and PE, locate the position with low impedance and repair it.

Fault Code	Fault Name	Fault Cause	Troubleshooting Recommendation
F50	DCV Level 1 Protection	Load abnormal fluctuation.	1. If the abnormality is introduced by an external fault, the inverter will automatically resume normal operation after the fault disappears, requiring no manual intervention. 2. If this alarm occurs frequently, affecting normal power plant generation, contact the dealer or after-sales service center.
F51	DCV Level 2 Protection	Load abnormal fluctuation.	
F52	Leakage current (GFCI) Multiple Fault Shutdown	North American safety regulations require manual recovery or waiting 24 hours after multiple faults; automatic recovery is not allowed.	Please check if the PV string's impedance to ground is too low.
F53	DC Arcing (AFCI) Multiple Fault Shutdown	North American safety regulations require manual recovery or waiting 24 hours after multiple faults; automatic recovery is not allowed.	1. After the machine reconnects to the grid, check if the voltage and current of each string abnormally decrease or become zero. 2. Check if the DC side terminals are securely connected.
F54	External Communication Link Broken	Inverter external device communication lost, possibly due to peripheral power supply issues, communication protocol mismatch, or no corresponding peripheral configured.	Judged based on the actual model and detection enable bits. Peripherals not supported by certain models will not be detected.

Fault Code	Fault Name	Fault Cause	Troubleshooting Recommendation
F55	Back-up Port Overload Fault	Prevents the inverter from sustaining overload output.	Turn off some off-grid loads to reduce the inverter's off-grid output power.
F56	Back-up Port Overvoltage Fault	Prevents inverter output overvoltage from damaging loads.	1. If it occurs occasionally, it may be caused by load switching and requires no manual intervention. 2. If it occurs frequently, contact the dealer or after-sales service center.
F57	External Box Fault	Excessive wait time for Box relay switching during grid-tied to off-grid transition.	1. Check if the Box is working normally. 2. Check if the Box communication wiring is correct.
F58	CT Loss Fault	CT connection wire disconnected (Japanese safety regulation requirement).	Check if the CT wiring is correct.
F59	Parallel Unit CAN Communication Abnormal	Parallel communication cable not securely connected or some units are offline.	Check if all units are powered on and if the parallel communication cables are securely connected.
F60	Parallel Unit Back-up Connection Reversed	Some units' backup lines are reversed with others.	Reconnect the backup lines.
F61	Inverter Soft Start Failure	Inverter soft start failure during off-grid cold start.	Check if the inverter module is damaged.

Fault Code	Fault Name	Fault Cause	Troubleshooting Recommendation
F62	AC HCT Failure	HCT sensor abnormality exists.	Disconnect the AC output side switch and DC input side switch, wait 5 minutes, then close the AC output side switch and DC input side switch. If the fault persists, contact the dealer or after-sales service center.
F63	GFCI HCT Failure	Leakage current sensor abnormality exists.	Disconnect the AC output side switch and DC input side switch, wait 5 minutes, then close the AC output side switch and DC input side switch. If the fault persists, contact the dealer or after-sales service center.
F64	Inverter Internal Failure	Inverter fault exists.	Disconnect the AC output side switch and DC input side switch, wait 5 minutes, then close the AC output side switch and DC input side switch. If the fault persists, contact the dealer or after-sales service center.
F65	AC Terminal Overtemperature	AC terminal temperature is too high, possible causes: 1. Inverter installation location is not ventilated. 2. Ambient temperature is too high. 3. Internal fan operation is abnormal.	1. Check if the ventilation at the inverter installation location is adequate and if the ambient temperature exceeds the maximum allowable range. 2. If ventilation is poor or ambient temperature is too high, improve ventilation and heat dissipation conditions. 3. If ventilation and ambient temperature are normal, contact the dealer or after-sales service center.

Fault Code	Fault Name	Fault Cause	Troubleshooting Recommendation
F66	INV Module Overtemperature	Inverter module temperature is too high, possible causes: 1. Inverter installation location is not ventilated. 2. Ambient temperature is too high. 3. Internal fan operation is abnormal.	1. Check if the ventilation at the inverter installation location is adequate and if the ambient temperature exceeds the maximum allowable range. 2. If ventilation is poor or ambient temperature is too high, improve ventilation and heat dissipation conditions. 3. If ventilation and ambient temperature are normal, contact the dealer or after-sales service center.
F67	Boost Module Overtemperature	Boost module temperature is too high, possible causes: 1. Inverter installation location is not ventilated. 2. Ambient temperature is too high. 3. Internal fan operation is abnormal.	1. Check if the ventilation at the inverter installation location is adequate and if the ambient temperature exceeds the maximum allowable range. 2. If ventilation is poor or ambient temperature is too high, improve ventilation and heat dissipation conditions. 3. If ventilation and ambient temperature are normal, contact the dealer or after-sales service center.

Fault Code	Fault Name	Fault Cause	Troubleshooting Recommendation
F68	AC Capacitor Overtemperature	Output filter capacitor temperature is too high, possible causes: 1. Inverter installation location is not ventilated. 2. Ambient temperature is too high. 3. Internal fan operation is abnormal.	1. Check if the ventilation at the inverter installation location is adequate and if the ambient temperature exceeds the maximum allowable range. 2. If ventilation is poor or ambient temperature is too high, improve ventilation and heat dissipation conditions. 3. If ventilation and ambient temperature are normal, contact the dealer or after-sales service center.
F69	PV IGBT Short Circuit Fault	Possible causes: 1. IGBT short circuit 2. Inverter sampling circuit abnormal	Disconnect the AC output side switch and DC input side switch, wait 5 minutes, then close the AC output side switch and DC input side switch. If the fault persists, contact the dealer or after-sales service center.
F70	PV IGBT Open Circuit Fault	1. Software issue causing no PWM generation: 2. Drive circuit abnormal: 3. IGBT open circuit	
F71	NTC Abnormal	NTC temperature sensor abnormal.	Disconnect the AC output side switch and DC input side switch, wait 5 minutes, then close the AC output side switch and DC input side switch. If the fault persists, contact the dealer or after-sales service center.

Fault Code	Fault Name	Fault Cause	Troubleshooting Recommendation
F72	PWM Abnormal	PWM abnormal waveform detected.	Disconnect the AC output side switch and DC input side switch, wait 5 minutes, then close the AC output side switch and DC input side switch. If the fault persists, contact the dealer or after-sales service center.
F73	CPU Interrupt Abnormal	CPU interrupt abnormal.	Disconnect the AC output side switch and DC input side switch, wait 5 minutes, then close the AC output side switch and DC input side switch. If the fault persists, contact the dealer or after-sales service center.
F74	Microelectronics Fault	Functional safety detected an abnormality.	Disconnect the AC output side switch and DC input side switch, wait 5 minutes, then close the AC output side switch and DC input side switch. If the fault persists, contact the dealer or after-sales service center.
F75	PV HCT Fault	boost current sensor abnormal.	Disconnect the AC output side switch and DC input side switch, wait 5 minutes, then close the AC output side switch and DC input side switch. If the fault persists, contact the dealer or after-sales service center.
F76	1.5V Reference Abnormal	Reference circuit fault.	Disconnect the AC output side switch and DC input side switch, wait 5 minutes, then close the AC output side switch and DC input side switch. If the fault persists, contact the dealer or after-sales service center.
F77	0.3V Reference Abnormal	Reference circuit fault.	
F78	CPLD Version Identification Error	CPLD version identification error.	Disconnect the AC output side switch and DC input side switch, wait 5 minutes, then close the AC output side switch and DC input side switch. If the fault persists, contact the dealer or after-sales service center.

Fault Code	Fault Name	Fault Cause	Troubleshooting Recommendation
F79	CPLD Communication Fault	CPLD and DSP communication content error or timeout.	Disconnect the AC output side switch and DC input side switch, wait 5 minutes, then close the AC output side switch and DC input side switch. If the fault persists, contact the dealer or after-sales service center.
F80	Model Identification Fault	Fault related to model identification error.	Disconnect the AC output side switch and DC input side switch, wait 5 minutes, then close the AC output side switch and DC input side switch. If the fault persists, contact the dealer or after-sales service center.

8.5.2.2.3 Troubleshooting (Fault Codes F81-F121)

Fault Code	Fault Name	Fault Cause	Troubleshooting Recommendation
F81	P-Bus Overvoltage		Disconnect the AC output side switch and the DC input side switch, wait for 5 minutes, then close the AC output side switch and the DC input side switch. If the fault persists, please contact the dealer or after-sales service center.

Fault Code	Fault Name	Fault Cause	Troubleshooting Recommendation
F82	N-Bus Overvoltage	BUS overvoltage, possible causes: 1. PV voltage too high; 2. Inverter BUS voltage sampling abnormal; 3. Poor isolation effect of the dual-split transformer at the inverter's output, causing mutual interference when two inverters are grid-connected, with one inverter reporting DC overvoltage during grid connection;	
F83	Bus Overvoltage (Sub CPU1)		Disconnect the AC output side switch and the DC input side switch, wait for 5 minutes, then close the AC output side switch and the DC input side switch. If the fault persists, please contact the dealer or after-sales service center.
F84	P-Bus Overvoltage (Sub CPU1)		

Fault Code	Fault Name	Fault Cause	Troubleshooting Recommendation
F85	N-Bus Overvoltage (Sub CPU1)	BUS overvoltage, possible causes: 1. PV voltage too high; 2. Inverter BUS voltage sampling abnormal; 3. Poor isolation effect of the dual-split transformer at the inverter's output, causing mutual interference when two inverters are grid-connected, with one inverter reporting DC overvoltage during grid connection;	
F86	Bus Overvoltage (Sub CPU2)		Disconnect the AC output side switch and the DC input side switch, wait for 5 minutes, then close the AC output side switch and the DC input side switch. If the fault persists, please contact the dealer or after-sales service center.
F87	P-Bus Overvoltage (Sub CPU2)		

Fault Code	Fault Name	Fault Cause	Troubleshooting Recommendation
F88	N-Bus Overvoltage (Sub CPU2)	BUS overvoltage, possible causes: 1. PV voltage too high; 2. Inverter BUS voltage sampling abnormal; 3. Poor isolation effect of the dual-split transformer at the inverter's output, causing mutual interference when two inverters are grid-connected, with one inverter reporting DC overvoltage during grid connection;	
F89	P-Bus Overvoltage (CPLD)		Disconnect the AC output side switch and the DC input side switch, wait for 5 minutes, then close the AC output side switch and the DC input side switch. If the fault persists, please contact the dealer or after-sales service center.

Fault Code	Fault Name	Fault Cause	Troubleshooting Recommendation
F90	N-Bus Overvoltage(CPLD)	BUS overvoltage, possible causes: 1. PV voltage too high; 2. Inverter BUS voltage sampling abnormal; 3. Poor isolation effect of the dual-split transformer at the inverter's output, causing mutual interference when two inverters are grid-connected, with one inverter reporting DC overvoltage during grid connection;	
F91	FlyCap Software Overvoltage	FlyCap overvoltage, possible causes: 1. PV voltage too high; 2. Inverter flycap voltage sampling abnormal;	Disconnect the AC output side switch and the DC input side switch, wait for 5 minutes, then close the AC output side switch and the DC input side switch. If the fault persists, please contact the dealer or after-sales service center.
F92	FlyCap Hardware Overvoltage		

Fault Code	Fault Name	Fault Cause	Troubleshooting Recommendation
F93	FlyCap Undervoltage	FlyCap undervoltage, possible causes: 1. PV energy insufficient; 2. Inverter flycap voltage sampling abnormal;	Disconnect the AC output side switch and the DC input side switch, wait for 5 minutes, then close the AC output side switch and the DC input side switch. If the fault persists, please contact the dealer or after-sales service center
F94	FlyCap Precharge Failure	FlyCap precharge failure, possible causes: 1. PV energy insufficient; 2. Inverter flycap voltage sampling abnormal;	Disconnect the AC output side switch and the DC input side switch, wait for 5 minutes, then close the AC output side switch and the DC input side switch. If the fault persists, please contact the dealer or after-sales service center
F95	FlyCap Precharge Abnormal	1. Unreasonable control loop parameters 2. Hardware damage	Disconnect the AC output side switch and the DC input side switch, wait for 5 minutes, then close the AC output side switch and the DC input side switch. If the fault persists, please contact the dealer or after-sales service center

Fault Code	Fault Name	Fault Cause	Troubleshooting Recommendation
F96, F97	String Overcurrent(String1-n) n: Determined based on the actual number of inverter strings	Possible causes: 1. String overcurrent; 2. String current sensor abnormal	Disconnect the AC output side switch and the DC input side switch, wait for 5 minutes, then close the AC output side switch and the DC input side switch. If the fault persists, please contact the dealer or after-sales service center
F99, F100	String Loss(String1-n) n: Determined based on the actual number of inverter strings	String fuse disconnected (if present)	Check if the fuse is disconnected.
F101	Battery1 Precharge fault	Battery1 precharge circuit fault (precharge resistor burned out, etc.)	Check if the precharge circuit is in good condition, and whether the battery voltage matches the bus voltage after only the battery is powered on. If not, please contact the dealer or after-sales service center.
F102	Battery1 Relay fault	Battery1 relay cannot operate normally	After powering on the battery, check if the battery relay is working and if a closing sound is heard. If not, please contact the dealer or after-sales service center.

Fault Code	Fault Name	Fault Cause	Troubleshooting Recommendation
F103	Battery1 Connection Overvoltage	Battery1 connection voltage exceeds the machine's rated range	Confirm if the battery voltage is within the machine's rated range.
F104	Battery2 Precharge fault	Battery2 precharge circuit fault (precharge resistor burned out, etc.)	Check if the precharge circuit is in good condition, and whether the battery voltage matches the bus voltage after only the battery is powered on. If not, please contact the dealer or after-sales service center.
F105	Battery2 Relay fault	Battery2 relay cannot operate normally	After powering on the battery, check if the battery relay is working and if a closing sound is heard. If not, please contact the dealer or after-sales service center.
F106	Battery2 Connection Overvoltage	Battery2 connection voltage exceeds the machine's rated range	Confirm if the battery voltage is within the machine's rated range.
F107	On-grid PWM Sync Failure	Abnormal during carrier synchronization grid connection	<ol style="list-style-type: none"> 1. Check if the synchronization cable connection is normal 2. Check if the master/slave settings are normal; 3. Disconnect the AC output side switch and the DC input side switch, wait for 5 minutes, then close the AC output side switch and the DC input side switch. If the fault persists, please contact the dealer or after-sales service center.

Fault Code	Fault Name	Fault Cause	Troubleshooting Recommendation
F108	DSP Communication fault	-	-
F109	External STS fault	Abnormal cable connection between the inverter and STS	Check if the wiring sequence of the harness between the inverter and the STS corresponds one-to-one in order.
F110	Export Limit Protection	<ol style="list-style-type: none"> 1. Inverter reports error and disconnects from grid 2. meter communication unstable 3. Reverse power flow condition occurs 	<ol style="list-style-type: none"> 1. Check if the inverter has other error messages. If yes, handle them accordingly; 2. Check if the meter connection is reliable; 3. If this alarm occurs frequently, affecting normal power plant generation, please contact the dealer or after-sales service center.
F111	Bypass Overload	-	-
F112	Black Start Failure	-	-
F113	Offgrid AC Ins Volt High	-	-
F114	Relay Failure2	Relay abnormal, causes: <ol style="list-style-type: none"> 1. Relay abnormal (relay short circuit) 2. Relay sampling circuit abnormal. 3. AC side wiring abnormal (may have poor connection or short circuit) 	Disconnect the AC output side switch and the DC input side switch, wait for 5 minutes, then close the AC output side switch and the DC input side switch. If the fault persists, please contact the dealer or after-sales service center.

Fault Code	Fault Name	Fault Cause	Troubleshooting Recommendation
F115	SVG Precharge Disabled	SVG precharge hardware failure	Contact the dealer or after-sales service center.
F116	Nighttime SVG PID Prevention fault	PID prevention hardware abnormal	
F117	DSP Version Recognition Error	DSP software version recognition error	Disconnect the AC output side switch and the DC input side switch, wait for 5 minutes, then close the AC output side switch and the DC input side switch. If the fault persists, please contact the dealer or after-sales service center.
F118	MOS Sustained Overvoltage	<ol style="list-style-type: none"> 1. Software issue causing inverter drive to turn off before flyback drive; 2. Inverter drive circuit abnormal causing failure to turn on; 3. PV voltage too high; 4. Mos voltage sampling abnormal; 	Disconnect the AC output side switch and the DC input side switch, wait for 5 minutes, then close the AC output side switch and the DC input side switch. If the fault persists, please contact the dealer or after-sales service center.
F119	Bus Short Circuit fault	Hardware damage	If the BUS short circuit fault occurs and the inverter remains offline, please contact the dealer or after-sales service center.

Fault Code	Fault Name	Fault Cause	Troubleshooting Recommendation
F120	Bus Sampling Abnormal	1. BUS voltage sampling hardware fault	Disconnect the AC output side switch and the DC input side switch, wait for 5 minutes, then close the AC output side switch and the DC input side switch. If the fault persists, please contact the dealer or after-sales service center.
F121	DC Side Sampling Abnormal	1. BUS voltage sampling hardware fault 2. Battery voltage sampling hardware fault 3. Dcrly relay fault	Disconnect the AC output side switch and the DC input side switch, wait for 5 minutes, then close the AC output side switch and the DC input side switch. If the fault persists, please contact the dealer or after-sales service center.

Fault Code	Fault Name	Fault Cause	Troubleshooting Recommendation
F122	PV Access Mode Setting Error	<p>PV access mode has three types, taking four MPPT channels as an example:</p> <ol style="list-style-type: none"> 1. Parallel mode: i.e., AAAA mode (same source mode), PV1-PV4 same source, 4 channels of PV connected to the same solar panel 2. Partial parallel mode: i.e., AACC mode, PV1 and PV2 same source connection, PV3 and PV4 same source connection 3. Independent mode: i.e., ABCD mode (different source), PV1, PV2, PV3, PV4 independent connection, 4 channels of PV each connected to one solar panel <p>If the actual PV access mode does not match the device's set PV</p>	<p>Check if the PV access mode is set correctly (ABCD, AACC, AAAA), reset the PV access mode according to the correct method</p> <ol style="list-style-type: none"> 1. Confirm that each channel of PV is correctly connected; 2. If the PV is correctly connected, check via APP or screen whether the currently set "PV Access Mode" corresponds to the actual access mode; 3. If the currently set "PV Access Mode" does not match the actual access mode, use the APP or screen to set the "PV Access Mode" to the mode consistent with the actual situation. After setting, disconnect the PV and AC power supply and restart; 4. After setting, if the current "PV Access Mode" matches the actual access mode but the fault still occurs, please contact the dealer or after-sales service center.

Fault Code	Fault Name	Fault Cause	Troubleshooting Recommendation
		access mode, this fault will be reported	

8.5.2.2.4 Troubleshooting (Fault Codes F122-F163)

Fault Code	Fault Name	Fault Cause	Troubleshooting Recommendation
F123	Multi-channel PV Phase Error	PV Input Mode Setting Error	<p>Check if the PV Access Mode is set correctly (ABCD, AACC, AAAA), and reset the PV Access Mode correctly.</p> <ol style="list-style-type: none"> 1. Confirm that all connected PV channels are correctly wired. 2. If the PV is correctly connected, check via the APP or screen whether the currently set "PV Access Mode" corresponds to the actual connection mode. 3. If the currently set "PV Access Mode" does not match the actual connection mode, use the APP or screen to set the "PV Access Mode" to the mode consistent with the actual situation. After setting, disconnect and restart the PV and AC power supply. 4. After setting, if the current "PV Access Mode" matches the actual connection mode but this fault still occurs, please contact the dealer or after-sales service center.

Fault Code	Fault Name	Fault Cause	Troubleshooting Recommendation
F124	Battery 1 Reverse Connection Fault	Battery 1 positive and negative terminals are reversed	Check if the polarities of the battery and the machine's terminals are consistent.
F125	Battery 2 Reverse Connection Fault	Battery 2 positive and negative terminals are reversed	Check if the polarities of the battery and the machine's terminals are consistent.
F126	Abnormal Battery Connection	Abnormal Battery Connection	Check if the battery is working properly.
F127	BAT Overtemperature	Battery temperature is too high. Possible causes: 1. Inverter installation location is not ventilated. 2. Ambient temperature is too high. 3. Internal fan operation is abnormal.	Disconnect the AC output side switch and the DC input side switch, wait for 5 minutes, then close the AC output side switch and the DC input side switch. If the fault persists, please contact the dealer or after-sales service center.
F128	Ref Voltage Abnormal	Reference circuit fault	Disconnect the AC output side switch and the DC input side switch, wait for 5 minutes, then close the AC output side switch and the DC input side switch. If the fault persists, please contact the dealer or after-sales service center.

Fault Code	Fault Name	Fault Cause	Troubleshooting Recommendation
F129	Cabinet Under Temperature	Cabinet temperature is too low. Possible cause: Ambient temperature is too low.	Disconnect the AC output side switch and the DC input side switch, wait for 5 minutes, then close the AC output side switch and the DC input side switch. If the fault persists, please contact the dealer or after-sales service center.
F130	AC Side SPD Fault	AC side surge protective device failure	Replace the AC side surge protective device.
F131	DC Side SPD Fault	DC side surge protective device failure	Replace the DC side surge protective device.
F132	Internal Fan Abnormal	Internal fan abnormal. Possible causes: 1. Fan power supply abnormal. 2. Mechanical fault (stall). 3. Fan aging or damage.	Disconnect the AC output side switch and the DC input side switch, wait for 5 minutes, then close the AC output side switch and the DC input side switch. If the fault persists, please contact the dealer or after-sales service center.
F133	External Fan Abnormal	External fan abnormal. Possible causes: 1. Fan power supply abnormal. 2. Mechanical fault (stall). 3. Fan aging or damage.	

Fault Code	Fault Name	Fault Cause	Troubleshooting Recommendation
F134	PID Diagnosis Abnormal	PID hardware fault or PV voltage too high causing PID suspension	PID suspension warning caused by high PV voltage does not require action. For PID hardware fault, you can clear the PID fault by turning the PID switch off and then on. Replace the PID device.
F135	Trip-Switch Trip Warning	Possible causes: Overcurrent or PV reverse connection caused the trip-switch to trip.	Contact the dealer or after-sales service center. The tripping reason is due to PV short circuit or reverse connection. Check if there is a historical PV short circuit warning or historical PV reverse connection warning. If present, a technician needs to inspect the corresponding PV condition. After inspection and confirming no fault, you can manually close the trip-switch and clear this warning via the APP interface's clear historical fault operation.
F136	Historical PV IGBT Short Circuit Warning	Possible causes: Overcurrent caused the trip-switch to trip.	Contact the dealer or after-sales service center. The technician needs to check the Boost hardware and external string for faults according to the historical PV short circuit warning subcode. After inspection and confirming no fault, you can clear this warning via the APP interface's clear historical fault operation.

Fault Code	Fault Name	Fault Cause	Troubleshooting Recommendation
F137 , F138	Historical PV Reverse Connection Warning (String 1-n) (n: determined based on the actual number of inverter strings)	Possible causes: PV reverse connection caused the trip-switch to trip.	Contact the dealer or after-sales service center. The technician needs to check the corresponding string for reverse connection and the PV panel configuration for voltage differences according to the historical PV reverse connection warning subcode. After inspection and confirming no fault, you can clear this warning via the APP interface's clear historical fault operation.
F139	Flash Read/Write Error Warning	Possible causes: 1. Flash content changed. 2. Flash life exhausted.	1. Upgrade to the latest firmware. 2. Contact the dealer or after-sales service center.
F140	Meter Comm Loss	This warning may only occur after enabling anti-backflow function. Possible causes: 1. Meter not connected. 2. Incorrect wiring of the communication cable between the meter and the inverter.	Check the meter wiring, connect the meter correctly. If the fault persists after inspection, please contact the dealer or after-sales service center.

Fault Code	Fault Name	Fault Cause	Troubleshooting Recommendation
F141	PV Panel Type Identification Failure	PV panel identification hardware abnormal	Contact the dealer or after-sales service center.
F142	PV String Mismatch	PV string mismatch. Two strings under the same MPPT have different open-circuit voltage configurations.	Check the open-circuit voltages of the two strings. Configure strings with the same open-circuit voltage under the same MPPT. Prolonged string mismatch poses safety risks.
F143	CT Not Connected	CT not connected	Check the CT wiring.
F144	CT Reverse Connection	CT reverse connection	Check the CT wiring.
F145	PE Loss	Ground wire not connected	Check the ground wire.
F146	String Terminal High Temperature (String 1~8)	Register 37176 PV terminal temperature warning subcode 1 is set	-
F147	String Terminal High Temperature (String 9~16)	Register 37177 PV terminal temperature warning subcode 2 is set	-
F148	String Terminal High Temperature (String 17~20)	Register 37178 PV terminal temperature warning subcode 3 is set	-

Fault Code	Fault Name	Fault Cause	Troubleshooting Recommendation
F149	Historical PV Reverse Connection Warning (String 33~48)	Possible causes: PV reverse connection caused the trip-switch to trip.	Contact the dealer or after-sales service center. The technician needs to check the corresponding string for reverse connection and the PV panel configuration for voltage differences according to the historical PV reverse connection warning subcode. After inspection and confirming no fault, you can clear this warning via the APP interface's clear historical fault operation.
F150	Battery 1 Low Voltage	Battery voltage below set value	-
F151	Battery 2 Low Voltage	Battery voltage below set value	-
F152	Low Voltage of Battery Power	In non-charging mode, battery voltage is below shutdown voltage	-
F153	Battery 1 High Voltage	-	-
F154	Battery 2 High Voltage	-	-

Fault Code	Fault Name	Fault Cause	Troubleshooting Recommendation
F155	Online Low Insulation Resistance	<p>1. Photovoltaic string shorted to protective earth.</p> <p>2. Photovoltaic string installed in a long-term humid environment with poor line-to-ground insulation.</p>	<p>1. Check the impedance of the photovoltaic string to protective earth. If a short circuit is found, rectify the short circuit point.</p> <p>2. Check if the inverter's protective earth wire is correctly connected.</p> <p>3. If it is confirmed that the impedance is indeed below the default value in rainy/cloudy environments, please reset the "Insulation Resistance Protection Point".</p>
F156	Micro-grid Overload Warning	backup terminal input current too high	Occasional occurrence requires no action; if this warning appears frequently, please contact the dealer or after-sales service center.
F157	Manual Reset	-	-
F158	Generator Phase Sequence Abnormal	-	-
F159	Multiplexed Port Configuration Abnormal	Multiplexed (generator) port is configured for micro-grid or large load, but a generator is actually connected	Use the APP to change the multiplexed (generator) port configuration.
F160	EMS Forced Off-grid	EMS issued forced off-grid command, but off-grid function is not enabled	Enable the off-grid function.

Fault Code	Fault Name	Fault Cause	Troubleshooting Recommendation
F161	Passive Anti-islanding Protection	-	-
F162	Grid Type Fault	Actual grid type (two-phase or split-phase) does not match the set safety standard	Switch to the corresponding safety standard based on the actual grid type.
F163	Grid Phase Instability	Grid abnormal: Grid voltage phase change rate does not comply with local grid standards.	<p>1. If it occurs occasionally, it may be due to temporary grid abnormality. The inverter will resume normal operation after detecting normal grid conditions, requiring no manual intervention.</p> <p>2. If it occurs frequently, check if the grid frequency is within the allowable range. If not, please contact the local power operator.</p>

8.5.2.2.5 Fault Symptom Handling

Fault Name	Fault Cause	Fault Handling Suggestions
Generator Failure	<ol style="list-style-type: none"> 1. This fault will be displayed continuously when a generator is not connected. 2. When the generator is operating, failure to meet generator safety regulations will trigger this fault. 	<ol style="list-style-type: none"> 1. If no generator is connected, ignore this fault. 2. When this fault appears due to a generator malfunction, it is normal. Wait for a period after the generator recovers, and the fault will clear automatically. 3. This fault does not affect the normal operation of off-grid mode. 4. When both the generator and the grid are connected and meet safety requirements, the grid has priority for grid connection, and the system will operate in grid-connected mode.
BMS Status Bit Error	BMS module failure	<p>Disconnect the AC output side switch and the DC input side switch. After 5 minutes, close the AC output side switch and the DC input side switch. If the fault persists, please contact the distributor or after-sales service center.</p>
Ambient Overtemperature	<ol style="list-style-type: none"> 1. Poor machine ventilation 2. Hot air flow back to the ambient temperature sampling point 	<p>Disconnect the AC output side switch and the DC input side switch. After 5 minutes, close the AC output side switch and the DC input side switch. If the fault persists, please contact the distributor or after-sales service center.</p>

Fault Name	Fault Cause	Fault Handling Suggestions
PV Terminal Overtemperature	PV terminal overtemperature, possible causes: 1. Poor ventilation at the inverter installation location. 2. Ambient temperature is too high. 3. Internal fan operation is abnormal.	1. Check if the ventilation at the inverter installation location is adequate and if the ambient temperature exceeds the maximum allowable range. 2. If ventilation is poor or the ambient temperature is too high, please improve its ventilation and heat dissipation conditions. 3. If both ventilation and ambient temperature are normal, please contact the distributor or after-sales service center.
BAT Terminal Overtemperature	BAT terminal overtemperature, possible causes: 1. Poor ventilation at the inverter installation location. 2. Ambient temperature is too high.	1. Check if the ventilation at the inverter installation location is adequate and if the ambient temperature exceeds the maximum allowable range.
AC Terminal Overtemperature Warning	AC terminal overtemperature, possible causes: 1. Poor ventilation at the inverter installation location. 2. Ambient temperature is too high. 3. Internal fan operation is abnormal.	2. If ventilation is poor or the ambient temperature is too high, please improve its ventilation and heat dissipation conditions. 3. If both ventilation and ambient temperature are normal, please contact the distributor or after-sales service center.

Fault Name	Fault Cause	Fault Handling Suggestions
BAT Terminal Overtemperature Warning	BAT terminal overtemperature, possible causes: 1. Poor ventilation at the inverter installation location. 2. Ambient temperature is too high.	1. Check if the ventilation at the inverter installation location is adequate and if the ambient temperature exceeds the maximum allowable range. 2. If ventilation is poor or the ambient temperature is too high, please improve its ventilation and heat dissipation conditions. 3. If both ventilation and ambient temperature are normal, please contact the distributor or after-sales service center.
Three-phase on-grid fault	Three-phase external wiring error	Re-wire the connections.
External STS Failure	Abnormal cable connection between the inverter and the STS	Check if the wiring sequence of the harness between the inverter and the STS corresponds one-to-one in order.

Fault Name	Fault Cause	Fault Handling Suggestions
Parallel Comm Timeout Shutdown	In a parallel system, if a slave unit fails to communicate with the master for more than 400 seconds	Check if the parallel communication harness is securely connected. Check for duplicate slave addresses.
Three-phase off-grid phase loss fault	Phase loss in a three-phase system group	1. Check if all inverters are powered on; 2. Check if each phase in the three-phase group is connected to an inverter;

Fault Name	Fault Cause	Fault Handling Suggestions
EPO	External triggering of the hardware emergency stop button or remote triggering of the emergency stop command	<ol style="list-style-type: none"> 1. If triggered remotely for intentional shutdown, it can be ignored; 2. If not intentionally triggered, please contact the dealer or after-sales service center.
High Combustible Gas Concentration	Automatically triggered when the combustible gas device detects a concentration of 20% LEL or higher	<ol style="list-style-type: none"> 1. After the fault occurs, the unit will automatically open the air damper to exhaust and reduce the concentration. The fault will clear automatically after the concentration stays below 5% LEL for 15 minutes. 2. If a cluster-level fire protection fault is triggered after this fault, the air damper will automatically close. Confirm the damper status within 30s to ensure the cluster-level fire protection operates in a sealed space. 3. Please contact the dealer or after-sales service center.
Mismatch Between Air Damper Open Command and Feedback Signal for Combustible Gas Device	Mismatch between the control signal to open the air damper and its feedback signal	<ol style="list-style-type: none"> 1. Check the harness signal connections for issues. 2. Please contact the dealer or after-sales service center.

Fault Name	Fault Cause	Fault Handling Suggestions
One-Key Shutdown	Check via the App if the one-key shutdown function is enabled	Disable the one-key shutdown.
Offline Shutdown	-	-
Remote Shutdown	-	-
On-Grid SPD Fault	-	<ol style="list-style-type: none"> 1. Try restarting the unit and observe if the fault clears; 2. If the fault persists after restarting, please contact the dealer or after-sales service center.
Off-Grid SPD Fault	-	<ol style="list-style-type: none"> 1. Try restarting the unit and observe if the fault clears; 2. If the fault persists after restarting, please contact the dealer or after-sales service center.
Child Node Communication Failure	Internal communication abnormality	<ol style="list-style-type: none"> 1. Try restarting the unit and observe if the fault clears; 2. If the fault persists after restarting, please contact the dealer or after-sales service center.

Fault Name	Fault Cause	Fault Handling Suggestions
Dehumidifier Communication Fault	Abnormal communication link between the dehumidifier and the LC control box	<ol style="list-style-type: none"> 1. Check the link communication harness and observe if the fault clears; 2. Try restarting the unit and observe if the fault clears; 3. If the fault persists after restarting, please contact the dealer or after-sales service center.
Combustible Gas Detection Device Communication Fault	<ol style="list-style-type: none"> 1. The combustible gas device was not properly configured with the 485 address set to 2 during factory settings. 2. Abnormal communication link between the combustible gas device and the LC control box 	<ol style="list-style-type: none"> 1. Check the link communication harness and observe if the fault clears; 2. Try restarting the unit and observe if the fault clears; 3. Use the method provided by the combustible gas device manufacturer to check if the device address is 2; if not, modify it; 4. If the fault persists after restarting, please contact the dealer or after-sales service center.
DG Communication Failure	Abnormal communication link between the control board and the diesel generator	<ol style="list-style-type: none"> 1. Check the link communication harness and observe if the fault clears; 2. Try restarting the unit and observe if the fault clears; 3. If the fault persists after restarting, please contact the dealer or after-sales service center.
Battery Over Voltage	<ol style="list-style-type: none"> 1. Individual cell voltage too high 2. Voltage sensing line abnormality 	

Fault Name	Fault Cause	Fault Handling Suggestions
	<ol style="list-style-type: none"> 1. Total battery voltage too high 2. Voltage sensing line abnormality 	<p>Record the fault phenomenon, restart the battery, wait a few minutes, confirm if the fault disappears. If the problem persists after restarting, please contact the after-sales service center.</p>
Battery Undervoltage	<ol style="list-style-type: none"> 1. Individual cell voltage too low 2. Voltage sensing line abnormality 	
	<ol style="list-style-type: none"> 1. Total battery voltage too low 2. Voltage sensing line abnormality 	
Battery Overcurrent	<ol style="list-style-type: none"> 1. Charging current too high, abnormal battery current limiting: sudden changes in temperature and voltage values 2. Inverter response abnormal 	
	Battery discharge current too high	
Battery Overtemperature	<ol style="list-style-type: none"> 1. Ambient temperature too high 2. Temperature sensor abnormality 	
Battery Undertemperature	<ol style="list-style-type: none"> 1. Ambient temperature too low 2. Temperature sensor abnormality 	

Fault Name	Fault Cause	Fault Handling Suggestions
Battery Terminal Overtemperature	Terminal temperature too high	
Battery Imbalance	<ol style="list-style-type: none"> 1. Excessive temperature difference. At different stages, the battery will limit power, i.e., limit charge/discharge current. Therefore, this issue is generally difficult to occur. 2. Cell capacity degradation, leading to excessive internal resistance, causing large temperature rise during overcurrent, resulting in large temperature difference. 3. Poor welding of cell tabs, causing rapid cell temperature rise during overcurrent. 4. Temperature sampling issue; 5. Power cable connection loose 	

Fault Name	Fault Cause	Fault Handling Suggestions
	1. Inconsistent cell aging levels 2. Slave board chip issues can also cause excessive cell voltage difference; 3. Slave board balancing issues can also cause excessive cell voltage difference 4. Harness issues	
Insulation Resistance	Insulation resistance damaged	Check if the ground wire is properly connected, restart the battery. If the problem persists after restart, please contact the after-sales service center.
Pre-charging Failure	Pre-charging failure	Indicates that during pre-charging, the voltage across the pre-charge MOS always exceeds the specified threshold. After powering off and restarting, observe if the fault persists. Check if the wiring is correct and if the pre-charge MOS is damaged.
Sensing Line Fault	Battery sensing line poor contact or disconnected	Check wiring, restart the battery. If the problem persists after restart, please contact the after-sales service center.
	Cell voltage sensing line poor contact or disconnected	Check wiring, restart the battery. If the problem persists after restart, please contact the after-sales service center.
	Cell temperature sensing line poor contact or disconnected	

Fault Name	Fault Cause	Fault Handling Suggestions
	Excessive error in dual-channel current comparison, or abnormal current sensing line circuit	
	Excessive error in dual-channel voltage comparison or MCU vs. AFE voltage comparison, or abnormal voltage sensing line circuit	
	Temperature sensing line circuit abnormal or poor contact/disconnected	
	Overvoltage level 5 or overtemperature level 5, tripping the three-terminal fuse	The three-terminal fuse is blown. Please contact the after-sales service center to replace the main control board.
Relay or MOS Overtemperature	Relay or MOS overtemperature	This fault indicates the MOSFET temperature exceeds the specified threshold. Power off and let it cool for 2 hours.
Shunt Overtemperature	Shunt overtemperature	This fault indicates the shunt temperature exceeds the specified threshold. Power off and let it cool for 2 hours.
BMS1 Other Fault 1 (Residential Storage)	Relay or MOS Open Circuit	<ol style="list-style-type: none"> 1. Upgrade software, power off and let it rest for 5 minutes, restart and see if the fault persists; 2. If it persists, replace the battery pack

Fault Name	Fault Cause	Fault Handling Suggestions
	Relay or MOS Short Circuit	<ol style="list-style-type: none"> 1. Upgrade software, power off and let it rest for 5 minutes, restart and see if the fault persists; 2. If it persists, replace the battery pack
	Communication abnormal between master and slave racks, or cell inconsistency between racks	<ol style="list-style-type: none"> 1. Check the slave battery information and software version, and whether the communication cable connection to the master is normal 2. Upgrade software
	Battery system loop harness abnormal, causing the interlock signal loop not to form	Check if the terminal resistor is installed correctly
	BMS and PCS communication abnormal	<ol style="list-style-type: none"> 1. Confirm if the communication cable interface definitions between the inverter and the connected battery are correct; 2. Please contact the after-sales service center to check backend data and observe if the inverter and battery software match correctly.
	BMS master and slave controller communication harness abnormal	<ol style="list-style-type: none"> 1. Check wiring, restart the battery; 2. Upgrade the battery software, if the problem persists after restart, please contact the after-sales service center.
	Communication loss between main negative chips	

Fault Name	Fault Cause	Fault Handling Suggestions
	Circuit breaker, shunt trip abnormal	<ol style="list-style-type: none"> 1. Power off and let it rest for 5 minutes, restart and see if the fault persists; 2. Observe the blind plugs at the bottom of the PACK and PCU, check if the communication pins are loose or bent;
	MCU self-test failure	Upgrade software, restart the battery. If the problem persists after restart, contact the after-sales service center.
	<ol style="list-style-type: none"> 1. Software version too low or BMS board damaged 2. Large number of parallel inverters, causing excessive inrush current during battery pre-charge 	<ol style="list-style-type: none"> 1. Upgrade software, observe if the fault persists 2. In parallel systems, black-start the battery first before starting the inverters
	MCU internal fault	Upgrade software, restart the battery. This usually indicates detection of MCU or external component damage. If the problem persists after restart, please contact the after-sales service center.
	Total control current exceeds the specified threshold	<ol style="list-style-type: none"> 1. Power off and let it rest for 5 minutes, restart and see if the fault persists; 2. Check if the inverter power setting is too high, exceeding the bus load capacity;
	Inconsistent cells in parallel racks	Confirm if the cells in the parallel racks are consistent
	Reverse polarity connection of parallel racks	Check if the positive and negative terminals of the parallel racks are reversed

Fault Name	Fault Cause	Fault Handling Suggestions
	Severe overtemperature/overvoltage etc. triggering the fire protection system	Contact the after-sales service center.
Air Conditioner Failure	Air conditioner abnormal failure	Try restarting the system. If the fault is not resolved, please contact the after-sales service center.
	Cabinet door not closed	Check if the cabinet door is properly closed
	Supply voltage too high	Confirm the supply voltage value meets the air conditioner input voltage requirements. Re-power after confirmation.
	Insufficient supply voltage	
	No voltage input	
	Unstable supply voltage	Try restarting the system. If the fault is not resolved, please contact the after-sales service center.
	Compressor voltage unstable	
	Sensor poor contact or damaged	
Air conditioner fan abnormal		
BMS1 Other Fault 2 (Residential Storage)	Internal voltage or current abnormality in DCDC	Refer to specific DC fault content.
	DCDC overload or heat sink overtemperature, etc.	

Fault Name	Fault Cause	Fault Handling Suggestions
	Cell sensing abnormal or inconsistent aging levels	Please contact the after-sales service center.
	Fan action not executed normally	Please contact the after-sales service center.
	Output terminal screw loose or poor contact	<ol style="list-style-type: none"> 1. Power off the battery, check wiring and output terminal screw condition 2. After confirmation, restart the battery, observe if the fault persists. If it persists, please contact the after-sales service center.
	Battery used for too long or cells severely damaged	Please contact the after-sales service center to replace the pack.
	<ol style="list-style-type: none"> 1. Software version too low or BMS board damaged 2. Large number of parallel inverters, causing excessive inrush current during battery pre-charge 	<ol style="list-style-type: none"> 1. Upgrade software, observe if the fault persists. 2. In parallel systems, black-start the battery first before starting the inverters.
	Heating film damaged	Please contact the after-sales service center.
	Heating film three-terminal fuse blown, heating function unavailable	Please contact the after-sales service center.
	Software model, cell type, hardware model mismatch	Check if the software model, SN, cell type, and hardware model are consistent. If not, please contact the after-sales service center.

Fault Name	Fault Cause	Fault Handling Suggestions
	Thermal management board communication line break	1. Power off and let it rest for 5 minutes, restart and see if the fault persists; 2. If the fault does not recover, contact after-sales to replace the pack.
	Pack fan fault signal triggered	
DCDC Fault	Output port voltage too high	Check the output port voltage. If the output port voltage is normal and the fault does not clear after restarting the battery, please contact the after-sales service center.
	DCDC module detects battery voltage exceeding maximum charging voltage	Stop charging, discharge to below 90% SOC or let it rest for 2 hours. If ineffective and the fault persists after restart, please contact the after-sales service center.
	Heat sink temperature too high	Let the battery rest for 1 hour for the heat sink temperature to drop. If ineffective and the fault persists after restart, please contact the after-sales service center.
	Battery discharge current too high	Check if the load exceeds the battery's discharge capability. Turn off the load or stop the PCS for 60 seconds. If ineffective and the fault persists after restart, please contact the after-sales service center.
	Output port power cable positive/negative reversed with parallel racks or PCS	Turn off the battery manual switch, check if the output port wiring is correct, restart the battery.

Fault Name	Fault Cause	Fault Handling Suggestions
	Output power relay cannot close	Check if the output port wiring is correct and if there is a short circuit. If ineffective and the fault persists after restart, please contact the after-sales service center.
	Power device temperature too high	Let the battery rest for 1 hour for the internal power device temperature to drop. If ineffective and the fault persists after restart, please contact the after-sales service center.
	Relay welded/stuck	If the fault persists after restart, please contact the after-sales service center.
Battery Rack Circulating Current Failure	1. Cell imbalance 2. First power-on without full charge calibration	Record the fault phenomenon, restart the battery, wait a few minutes, confirm if the fault disappears. If the problem persists after restarting, please contact the after-sales service center.
BMS1 Other Fault 3 (Large-scale Storage)	Communication abnormal with Linux module	1. Check if the communication cable link is normal 2. Upgrade software, restart the battery and observe if the fault persists. If it persists, please contact the after-sales service center.
	Cell temperature rise too fast	Cell abnormal, contact after-sales to replace the pack.
	SOC below 10%	Charge the battery.
	SN writing does not comply with rules	Check if the SN digit count is normal. If abnormal, please contact the after-sales service center.

Fault Name	Fault Cause	Fault Handling Suggestions
	1. Daisy chain communication abnormal within a battery rack 2. Inconsistent cell aging levels between battery racks	1. Check the pack contact condition within a single rack 2. Confirm the usage status of each rack, such as cumulative charge/discharge capacity, cycle count, etc. 3. Please contact the after-sales service center.
	High humidity inside pack	-
	Fuse blown	Contact after-sales to replace the pack.
	Battery low power	Charge the battery.
BMS1 Other Fault 4 (Large-scale Storage)	Circuit breaker abnormal	Contact after-sales to replace the pack.
	External device abnormal	Contact after-sales to replace the pack.
Contact Failure 1	-	-
Contact Failure 2	-	-
Overload Protection (Ksic)	Sustained overload (exceeding 690kVA) for 10s	Please contact the after-sales service center.
Overload Protection (Smart Port)	Sustained overload (exceeding 690kVA) for 10s	Please contact the after-sales service center.
Overcurrent Protection (Ksic)	-	-

Fault Name	Fault Cause	Fault Handling Suggestions
Overcurrent Protection (Smart Port)	-	-
Master AC On Meter Comm Error	<ol style="list-style-type: none"> 1. Possibly the meter is not connected to the master 2. Possibly the meter communication cable is loose 	<ol style="list-style-type: none"> 1. Check if the meter is connected to the master 2. Check if the meter communication cable is loose
Parallel Slave Meter Error	Meter connected to a slave unit	Set the unit with the meter connected as the master
Slave AC On Timeout with Master	<ol style="list-style-type: none"> 1. Slave address setting error 2. Slave communication cable loose 	<ol style="list-style-type: none"> 1. Check for duplicate slave addresses 2. Check if the parallel communication cable is loose

9 technical parameter

9.1 Inverter Parameters

Technical Data	GW600 0-ET-20	GW8000 -ET-20	GW990 0-ET-20	GW10K- ET-20	GW12K- ET-20	GW15K- ET-20
Battery Input Data						
Battery Type	Li-Ion	Li-Ion	Li-Ion	Li-Ion	Li-Ion	Li-Ion
Nominal Battery Voltage (V)	500	500	500	500	500	500
Battery Voltage Range (V)	150~720	150~720	150~720	150~720	150~720	150~720
Start-up Voltage (V)	150	150	150	150	150	150
Number of Battery Input	1	1	1	1	1	1
Max. Continuous Charging Current (A)	30	30	40	40	40	40
Max. Continuous Discharging Current (A)	30	30	40	40	40	40
Max. Charge Power (W)	9000	12000	15000	15000	18000	24000
Max. Discharge Power (W)	6600	8800	11000	11000	13200	16500
PV String Input Data						
Max. Input Power (W) *2	9600	12800	16000	16000	19200	24000
Max. Input Voltage (V) *3*4	1000	1000	1000	1000	1000	1000

MPPT Operating Voltage Range (V) *5	120~850	120~850	120~850	120~850	120~850	120~850
MPPT Voltage Range at Nominal Power (V)	220~850	285~850	260~850	260~850	285~850	380~850
Start-up Voltage (V)	150	150	150	150	150	150
Nominal Input Voltage (V)	620	620	620	620	620	620
Max. Input Current per MPPT (A)	16	16	16	16	16	16
Max. Short Circuit Current per MPPT (A)	24	24	24	24	24	24
Max. Backfeed Current to The Array (A)	0	0	0	0	0	0
Number of MPP Trackers	2	2	3	3	3	3
Number of Strings per MPPT	1	1	1	1	1	1
AC Output Data (On-grid)						
Nominal Output Power (W)	6000	8000	9990	10000	12000	15000
Max. Output Power (W)	6000	8000	9990	10000	12000	15000
Nominal Apparent Power Output to Utility Grid (VA)	6000	8000	9990	10000	12000	15000
Max. Apparent Power Output to Utility Grid (VA) *6	6000	8000	9990	10000	12000	15000

Nominal Apparent Power from Utility Grid (VA)	6000	8000	10000	10000	12000	15000
Max. Apparent Power from Utility Grid (VA)	12000	16000	20000	20000	20000	20000
Nominal Output Voltage (V)	400/380, 3L/N/PE	400/380, 3L/N/PE	400/380, 3L/N/PE	400/380, 3L/N/PE	400/380, 3L/N/PE	400/380, 3L/N/PE
Output Voltage Range (V) *7	170~290	170~290	170~290	170~290	170~290	170~290
Nominal AC Grid Frequency (Hz)	50/60	50/60	50/60	50/60	50/60	50/60
AC Grid Frequency Range (Hz)	45~65	45~65	45~65	45~65	45~65	45~65
Max. AC Current Output to Utility Grid (A) *8	8.7	11.6	14.5	14.5	17.4	21.7
Max. AC Current From Utility Grid (A)	15.7	21	26.1	26.1	26.1	26.1
Max. Output Fault Current (Peak and Duration) (A)	200Aat 1ms	200Aat 1ms	200Aat 1ms	200Aat 1ms	200Aat 1ms	200Aat 1ms
Inrush Current (Peak and Duration) (A)	150Aat 1ms	150Aat 1ms	150Aat 1ms	150Aat 1ms	150Aat 1ms	150Aat 1ms
Nominal Output Current (A)	8.7	11.6	14.3	14.5	17.4	21.7
Power Factor	0.8 leading ~0.8 lagging	0.8 leading ~0.8 lagging	0.8 leading ~0.8 lagging	0.8 leading ~0.8 lagging	0.8 leading ~0.8 lagging	0.8 leading ~0.8 lagging

Max. Total Harmonic Distortion	<3%	<3%	<3%	<3%	<3%	<3%
Maximum Output Overcurrent Protection (A)	56	56	56	56	56	56
AC Output Data (Back-up)						
Back-up Nominal Apparent Power (VA)	6000	8000	10000	10000	12000	15000
Max. Output Apparent Power (VA) ^{*9}	6000 (12,000 at60sec)	8000 (16,000 at60sec)	10000 (18000 at60sec)	10000 (18000 at60sec)	12000 (18000 at60sec)	15000 (18000 at60sec)
Max. Output Apparent Power with Grid (VA)	6000	8000	10000	10000	12000	15000
Nominal Output Current (A)	8.7	11.6	14.5	14.5	17.4	21.7
Max. Output Current (A)	13 (17.4at 60sec)	17.4 (23.3at6 0sec)	21.7 (26.1at 60sec)	21.7 (26.1at6 0sec)	21.7 (26.1at6 0sec)	21.7 (26.1at60 sec)
Max. Output Fault Current (Peak and Duration) (A)	56at3us	56at3us	56at3u s	56at3us	56at3us	56at3us
Inrush Current (Peak and Duration) (A)	150Aat 1ms	150Aat1 ms	150Aat 1ms	150Aat 1ms	150Aat 1ms	150Aat1 ms
Maximum Output Overcurrent Protection (A)	56	56	56	56	56	56
Nominal Output Voltage (V)	400/38 0	400/380	400/38 0	400/38 0	400/38 0	400/380

Nominal Output Frequency (Hz)	50/60	50/60	50/60	50/60	50/60	50/60
Output THDv (@Linear Load)	<3%	<3%	<3%	<3%	<3%	<3%
Efficiency						
Max. Efficiency	98.0%	98.0%	98.2%	98.2%	98.2%	98.2%
European Efficiency	97.2%	97.2%	97.5%	97.5%	97.5%	97.5%
Max. Battery to AC Efficiency	97.2%	97.5%	97.5%	97.5%	97.5%	97.5%
MPPT Efficiency	99.5%	99.5%	99.5%	99.5%	99.5%	99.5%
Protection						
PV Insulation Resistance Detection	Integrated	Integrated	Integrated	Integrated	Integrated	Integrated
PV AFCI3.0	Optional	Optional	Optional	Optional	Optional	Optional
Residual Current Monitoring	Integrated	Integrated	Integrated	Integrated	Integrated	Integrated
PV Reverse Polarity Protection	Integrated	Integrated	Integrated	Integrated	Integrated	Integrated
Battery Reverse Polarity Protection	Integrated	Integrated	Integrated	Integrated	Integrated	Integrated
Anti-islanding Protection	Integrated	Integrated	Integrated	Integrated	Integrated	Integrated
AC Overcurrent Protection	Integrated	Integrated	Integrated	Integrated	Integrated	Integrated
AC Short Circuit Protection	Integrated	Integrated	Integrated	Integrated	Integrated	Integrated

AC Overvoltage Protection	Integrated	Integrated	Integrated	Integrated	Integrated	Integrated
DC Switch	Integrated	Integrated	Integrated	Integrated	Integrated	Integrated
DC Surge Protection	Type II	Type II	Type II	Type II	Type II	Type II
AC Surge Protection	Type II	Type II	Type II	Type II	Type II	Type II
Remote Shutdown	Integrated	Integrated	Integrated	Integrated	Integrated	Integrated
General Data						
Operating Temperature Range (°C)	-35~+60	-35~+60	-35~+60	-35~+60	-35~+60	-35~+60
Storage Temperature (°C)	-40~+85	-40~+85	-40~+85	-40~+85	-40~+85	-40~+85
Relative Humidity	0~100%	0~100%	0~100%	0~100%	0~100%	0~100%
Operating Environment	Outdoor	Outdoor	Outdoor	Outdoor	Outdoor	Outdoor
Max. Operating Altitude (m)	4000	4000	4000	4000	4000	4000
Cooling Method	Natural Convection	Natural Convection	Natural Convection	Natural Convection	Natural Convection	Natural Convection
User Interface	LED, WLAN+APP	LED, WLAN+APP	LED, WLAN+APP	LED, WLAN+APP	LED, WLAN+APP	LED, WLAN+APP
Communication with BMS	RS485, CAN	RS485, CAN	RS485, CAN	RS485, CAN	RS485, CAN	RS485, CAN
Communication with Meter	RS485	RS485	RS485	RS485	RS485	RS485

Communication with Portal	WiFi+LAN+Bluetooth	WiFi+LAN+Bluetooth	WiFi+LAN+Bluetooth	WiFi+LAN+Bluetooth	WiFi+LAN+Bluetooth	WiFi+LAN+Bluetooth
Weight (kg)	23	23	25	25	25	25
Dimension (W×H×D mm)	496*460*221	496*460*221	496*460*221	496*460*221	496*460*221	496*460*221
Noise Emission (dB)	<30	<30	<30	<30	<45	<45
Topology	Non-isolated	Non-isolated	Non-isolated	Non-isolated	Non-isolated	Non-isolated
Self-consumption at Night (W) *10	<15	<15	<15	<15	<15	<15
Ingress Protection Rating	IP66	IP66	IP66	IP66	IP66	IP66
DC Connector	MC4 (4~6mm ²)	MC4 (4~6mm ²)	MC4 (4~6mm ²)	MC4 (4~6mm ²)	MC4 (4~6mm ²)	MC4 (4~6mm ²)
AC Connector	Feed-Through Terminal Blocks UW10	Feed-Through Terminal Blocks UW10	Feed-Through Terminal Blocks UW10	Feed-Through Terminal Blocks UW10	Feed-Through Terminal Blocks UW10	Feed-Through Terminal Blocks UW10
Environmental Category	4K4H	4K4H	4K4H	4K4H	4K4H	4K4H
Pollution Degree	III	III	III	III	III	III
Overvoltage Category	DC II / AC III	DC II / AC III	DC II / AC III	DC II / AC III	DC II / AC III	DC II / AC III
Protective Class	I	I	I	I	I	I

The Decisive Voltage Class (DVC)	Battery : C PV: C AC: C Com: A	Battery : C PV: C AC: C Com: A	Battery : C PV: C AC: C Com: A	Battery : C PV: C AC: C Com: A	Battery : C PV: C AC: C Com: A	Battery : C PV: C AC: C Com: A
Mounting Method	Wall Mounted	Wall Mounted	Wall Mounted	Wall Mounted	Wall Mounted	Wall Mounted
Active Anti-islanding Method	AFDPF + AQDPF* ₁₁	AFDPF + AQDPF* ₁₁	AFDPF + AQDPF* ₁₁	AFDPF + AQDPF* ₁₁	AFDPF + AQDPF* ₁₁	AFDPF + AQDPF* ₁₁
Type of Electrical Supply System	Three phase Grid	Three phase Grid	Three phase Grid	Three phase Grid	Three phase Grid	Three phase Grid
Country of Manufacture	China	China	China	China	China	China
Certification* ¹²						
Grid Standards	VDE-AR-N 4105, EN50549-1					
Safety Regulation	IEC62109-1&2					
EMC	EN61000-6-1, EN61000-6-2, EN61000-6-3, EN61000-6-4					

*2: Max. input power, not continuous for 1.6*normal power. Besides, in Australia, for most of the PV modules, the max. input power can reach 2*P_n, for example, the max. input power of GW6000-ET-20 can reach 12000W.

*3: For 1000V system, the maximum operating voltage is 950V.

*4: When the input voltage ranges from 950V to 1000V, the inverter will enter the standby mode. When the input voltage returns to the MPPT operating voltage range, the inverter will resume normal operating mode.

*5: Please refer to the user manual for the MPPT Voltage Range at Nominal Power.

*6: According to the local grid regulation.

*7: Output Voltage Range: phase voltage.

*8: When the three-unbalance function is activated, the Max. AC Current Output to the on-grid load can reach 13A, 17.4A, 21.7A, 21.7A and 21.7A respectively.

*9: Can be reached only if PV and battery power is enough.

*10: No Back-up Output.

*11: AFDPF: Active Frequency Drift with Positive Feedback, AQDPF: Active Q Drift with Positive Feedback.

*12: Not all certifications & standards are listed, check the official website for details.

9.2 Battery Parameters

9.2.1 Lynx home F

Technical parameters	LX F6.6-H	LX F9.8-H	LX F13.1-H	LX F16.4-H
Usable Energy(kWh) ^{*1}	6.55	9.83	13.1	16.38
Battery Module	LX F3.3-H: 38.4V 3.27kWh			
Number of Modules	2	3	4	5
Cell Type	LFP (LiFePO ₄)			
Cell Configuration	64S1P	96S1P	128S1P	160S1P
Nominal Voltage (V)	204.8	307.2	409.6	512
Operating Voltage Range (V)	182.4~230.4	273.6~345.6	364.8~460.8	456~576
Nominal Dis-/Charge Current(A) ^{*2}	25			
Nominal Power (kW) ^{*2}	5.12	7.68	10.24	12.8
Operating Temperature (°C)	Charge: 0 ~ +50; Discharge: -20 ~ +50			
Relative Humidity	0~95%			

Technical parameters		LX F6.6-H	LX F9.8-H	LX F13.1-H	LX F16.4-H
Max. Operating Altitude (m)		2000			
Communication		CAN			
Weight (kg)		115	158	201	244
Dimensions (W×H×D mm)		600*625*380	600*780*380	600*935*380	600*1090*380
Enclosure Type		IP55			
Installation Location		Grounded			
Standard and Certification	Safety	IEC62619, IEC62040, CEC			
	EMC	CE, RCM			
	Transportation	UN38.3			
<p>*1: Test conditions, 100% DOD, 0.2°C charge & discharge at +25±2 °C for battery system at beginning life. System Usable Energy may vary with different Inverter.</p> <p>*2: Nominal Dis-/Charge Current and power derating will occur related to Temperature and SOC.</p>					

9.2.2 Lynx home F Plus+

Technical parameters		LX F6.6-H	LX F9.8-H	LX F13.1-H	LX F16.4-H
Usable Energy(kWh) ^{*1}		6.55	9.83	13.10	16.38
Battery Module		LX F3.3-H: 38.4V 3.27kWh			
Number of Modules		2	3	4	5
Cell Type		LFP(LiFePO ₄)			
Cell Configuration		64S1P	96S1P	128S1P	160S1P

Technical parameters		LX F6.6-H	LX F9.8-H	LX F13.1-H	LX F16.4-H
Nominal Voltage (V)		204.8	307.2	409.6	512
Operating Voltage Range (V)		182.4~230.4	273.6~345.6	364.8~460.8	456~576
Nominal Dis-/Charge Current (A) ^{*2}		25			
Nominal Power (kW) ^{*2}		5.12	7.68	10.24	12.8
Operating Temperature (°C)		Charge: 0 ~ +50; Discharge: -20 ~ +50			
Relative Humidity		0~95%			
Max. Operating Altitude (m)		2000			
Communication		CAN			
Weight (kg)		115	158	201	244
Dimensions (W×H×D mm)		600*610*380	600*765*380	600*920*380	600*1075*380
Enclosure Type		IP55			
Storage Temperature (°C)		-20 ~ +45 (≤ One Month); 0 ~ +35 (< One Year)			
Mounting Method		Grounded			
Round-trip Efficiency		96.4%			
Cycle Life		≥ 3500 @1C/1C			
Standard and Certification	Safety	IEC62619, IEC 62040, VDE2510-50, CEC			
	EMC	CE, RCM			
	Transportation	UN38.3			

Technical parameters	LX F6.6-H	LX F9.8-H	LX F13.1-H	LX F16.4-H
<p>*1 : Test conditions , 100% DOD, 0.2C charge & discharge at +25±2 °C for battery system at beginning life. System Usable Energy may vary with different Inverter.</p> <p>*2 : Nominal Dis-/Charge Current and power derating will occur related to Temperature and SOC.</p> <p>*3 : Based on 2.5~3.65V voltage range @25±2°C of Cell under 11C/1C test condition and 80% EOL.</p>				

9.2.3 Lynx home F G2

Technical Data	LX F6.4-H-20	LX F9.6-H-20	LX F12.8-H-20	LX F16.0-H-20	LX F19.2-H-20	LX F22.4-H-20	LX F25.6-H-20	LX F28.8-H-20
Usable Energy (kWh)*1	6.4	9.6	12.8	16.0	19.2*2	22.4*2	25.6	28.8
Battery Module	LX F3.2-20: 64V 3.2kWh							
Number of Modules	2	3	4	5	6	7	8	9
Cell Type	LFP (LiFePO ₄)							
Cell Configuration	(20S)2 S1P	(20S)3 S1P	(20S)4 S1P	(20S)5 S1P	(20S)6 S1P	(20S)7 S1P	(20S)8 S1P	(20S)9 S1P
Nominal Voltage (V)	128	192	256	320	384	448	512	576
Operating Voltage Range (V)	114.8~ 144.4	172.2~ 216.6	229.6~ 288.8	287~ 361	344.4~ 433.2	401.8~ 505.4	459.2~ 577.6	516.6~ 649.8
Nominal Dis-/Charge Current (A)*3	35							

Technical Data	LX F6.4-H-20	LX F9.6-H-20	LX F12.8-H-20	LX F16.0-H-20	LX F19.2-H-20	LX F22.4-H-20	LX F25.6-H-20	LX F28.8-H-20
Max. Continuous Dis-/Charge Current (A)	35							
Nominal Power (kW)*3	4.48	6.72	8.96	11.2	13.44	15.68	17.92	20.16
Operating Temperature Range (°C)*4	-20~+50							
Relative Humidity	0 ~ 95%							
Max. Operating Altitude (m)	3000							
Communication	CAN							
Weight (kg)	86	120	154	188	222	256	290	324
Dimensions (W×H×D mm)	600×559×380	600×715×380	600×871×380	600×1027×80	600×1183×80	600×1339×80	600×1495×80	600×1651×80
Ingress Protection Rating	IP55							
Storage Temperature (°C)	-20~+45(≤One Month) ; 0~+35(≤One Year)							
Mounting Method	Grounded							

Technical Data		LX F6.4-H-20	LX F9.6-H-20	LX F12.8-H-20	LX F16.0-H-20	LX F19.2-H-20	LX F22.4-H-20	LX F25.6-H-20	LX F28.8-H-20
Round-trip Efficiency		94%							
Cycle Life*5		> 4000							
Standard and Certification	Safety	IEC62619、IEC62040-1、IEC63056、VDE2510、CE							
	EMC	CE, RCM							
	Transportation	UN38.3							

9.3 Smart Meter Technical Data

9.3.1 GM330

model	GM330
Measurement Range	
Supported Grid Type	1P2W/3P3W/3P4W
Operating voltage (Vac)*	3P4W: 100~472 L-N 3P3W: 100~472 L-L
Frequency (Hz)	50/60
CT ratio	nA: 5A
Accuracy Parameters	
voltage/current	Class 0.5
Active Energy	Class 0.5

model	GM330
Reactive Energy	Class 1
Communication Parameters	
Communication Method	RS485
Communication Distance (m)	1000
General Parameters	
Dimensions (W*H*D mm)	72*85*72
Housing	4-module
Weight (g)	240
Mounting Method	DIN rail
User Interface	4 LEDs, Reset button
Power Consumption (W)	< 5
Environmental Parameters	
IP Rating	IP20
Operating Temperature Range (°C)	-30 to +70
Storage Temperature Range (°C)	-30 to +70
Relative Humidity (non-condensing)	0-95%
Max. Operating Altitude (m)	3000

*Supports 1.1 times rated voltage connection.

*The standard CT for the meter has been uniformly changed to the 120A:40mA specification. Meters equipped with the 200A:50mA specification CT will no longer be sold after June 2026.

9.3.2 GM3000

Technical Parameter		GM3000
Application		Three-phase
Voltage	Nominal Voltage	3L+N/400V
	Voltage Range	100V~240V
	Frequency	50Hz/60Hz
Current	Rated Current	CT in: 120A/40mA;
	Current Range	0.48A~120A
Power Consumption		<3W
Data Detection		Voltage/Current/Active Power/Reactive Power/Power Factor/Frequency
Energy Calculation		Active/Reactive Power
Accuracy	Voltage/Current	Class I
	Active	Class I
	Reactive	Class II
Communication		RS485 (Max. Baud Rate9600/ModBusProtocol/Max. Cable Length100m)
Display		LED, USB, Reset Button
Device	Dimensions (L x W x Hmm)	36 x 85 x 66.5
	Weight (g)	450
	Ingress Protection Rating	IP20(Indoor)
	Mounting Method	Backplate Mounting
Operating Temperature		-25 ~ +60° C
Storage Temperature		-25 ~ +60° C
Humidity		<95% Non-condensing
Operating Altitude(m)		< 2000m
Safe Service Life (Years)		≥25

9.4 Smart Dongle Technical Data

9.4.1 WiFi/LAN Kit-20

technical parameter		WiFi/LAN Kit-20
Output Voltage (V)		5
Power Consumption (W)		≤2
Communication Interface		USB
Communication Parameters	Ethernet	10M/100Mbps Auto-negotiation
	Wireless	IEEE 802.11 b/g/n @2.4 GHz
	Bluetooth	Bluetooth V4.2 BR/EDR and Bluetooth LE Standard
Mechanical Parameters	Dimensions (W×H×D mm)	48.3*159.5*32.1
	Weight (g)	82
	Ingress Protection Rating	IP65
	Mounting Method	USB Port Plug-in
Operating Temperature Range (°C)		-30~+60
Storage Temperature Range (°C)		-40~+70
Relative Humidity		0-95%
Max. Operating Altitude (m)		4000

9.4.2 4G Kit-CN-G20

Product Model	4G Kit-CN-G20
Device Management	
Max. Supported Inverter Quantity	1
Power Parameters	
Input Voltage (V)	5
Power Consumption (W)	≤4
Interface Type	USB
Communication Parameters	
4G/3G/2G	LTE-FDD: B1/B3/B5/B8 LTE-TDD: B34/B39/B40/B41
GNSS Positioning	/
Bluetooth	Bluetooth V5.0

Product Model	4G Kit-CN-G20
Mechanical Parameters	
Dimensions (W×H×D mm)	48.3*95.5*32.1
Weight (g)	87
indicator	LED* 2
Mounting Method	Plug and Play
SIM Card Size	Micro sim, 15mm*12mm
Environmental Parameters	
Operating Temperature Range (°C)	-30~+65
Storage Temperature Range (°C)	-40~+70
Relative Humidity	0-100%
IP Rating	IP66
Max. Operating Altitude (m)	4000
Compliant Standards	
Certification	SRRC、CTA

9.4.3 4G Kit-CN-G21

Product Model	4G Kit-CN-G21
Device Management	
Max. Supported Inverter Quantity	1
Power Parameters	
Input Voltage (V)	5
Power Consumption (W)	≤4
Interface Type	USB
Communication Parameters	
4G/3G/2G	LTE-FDD: B1/B3/B5/B8 LTE-TDD: B34/B39/B40/B41

Product Model	4G Kit-CN-G21
GNSS Positioning	Beidou, GPS
Bluetooth	Bluetooth V5.0
Mechanical Parameters	
Dimensions (Width×Height×Thickness mm)	48.3*95.5*32.1
Weight (g)	87
indicator	LED* 2
Mounting Method	Plug and Play
SIM Card Size	Micro sim, 15mm*12mm
Environmental Parameters	
Operating Temperature Range (°C)	-30~+65
Storage Temperature Range (°C)	-40~+70
Relative Humidity	0-100%
IP Rating	IP66
Max. Operating Altitude (m)	4000
Compliant Standards	
Certification	SRRC, CTA

9.4.4 Ezlink3000

model	Ezlink3000
General Parameters	
Connection Interface	USB
Ethernet Interface (Optional)	10/100Mbps auto-negotiation, communication distance ≤100m
Mounting Method	Plug and Play
indicator	LED indicator

model	Ezlink3000
Dimensions (W x H x D mm)	49x153x32
Weight (g)	130
Power Consumption (W)	≤2 (typical)
Wireless Parameters	
Bluetooth Communication	Bluetooth 5.1
WiFi Communication	802.11 b/g/n(2.412GHz-2.484GHz)
Operating Mode	STA
Environmental Parameters	
Operating Temperature Range (°C)	-30 ~ +60
Storage Temperature Range (°C)	-30 ~ +70
Relative Humidity	0-100% (non-condensing)
Ingress Protection Rating	IP65
Maximum Operating Altitude (m)	4000

9.4.5 LS4G Kit-CN

technical parameter	LS4G Kit-CN
General Data	
Maximum Supported Inverter Quantity	1
Interface Type	USB
Mounting Method	Plug and Play
indicator	LED indicator

technical parameter	LS4G Kit-CN
Dimensions (Width × Height × Thickness mm)	49*96*32
SIM Card Dimensions (mm)	15*12
IP Rating	IP65
Power Consumption (W)	<4
Operating Environment Temperature (°C)	-30~60°C
Storage Environment Temperature (°C)	-40~70°C
Relative Humidity	0-100% (no condensation)
Max. Operating Altitude (m)	4000
Wireless Parameters	
LTE-FDD	B1/B3/B5/B8
LTE-TDD	B34/B38/B39/B40/B41
GSM/GPRS	B3/B8
Safe Service Life (years)	≥25

9.4.6 4G Kit (China)

technical parameter	4G Kit-CN
General Data	
Max. Supported Inverter Quantity	1
Interface Type	USB
Mounting Method	Plug and Play
indicator	LED indicator
Dimensions (Width×Height×Thickness mm)	49*96*32
SIM Card Size (mm)	15*12
IP Rating	IP65

technical parameter	4G Kit-CN
Power Consumption (W)	<4
Operating Environment Temperature (°C)	-30~60°C
Storage Environment Temperature (°C)	-40~70°C
Relative Humidity	0-100% (no condensation)
Max. Operating Altitude (m)	4000
Wireless Parameters	
LTE-FDD	B1/B3/B5/B8
LTE-TDD	B34/B38/B39/B40/B41
GSM/GPRS	B3/B8
Safe Service Life (years)	≥25

10 Appendix

10.1 FAQ

10.1.1 How to Upgrade the Device Version

You can view or upgrade the following through the firmware information:
The inverter's DSP version, ARM version, communication module software version, battery's BMS version, DCDC version, etc.

- **Prompted Upgrade:**

The user opens the App, and an upgrade prompt pops up on the home page. The user can choose whether to upgrade. If upgrade is selected, follow the on-screen instructions to complete the upgrade.

- **Regular Upgrade:**

Navigate to **[Home]** > **[Settings]** > **[Firmware Information]** to enter the firmware information viewing interface.

Click "Check for Updates". If a new version is available, follow the on-screen instructions to complete the upgrade.

- **Forced Upgrade:**

The App pushes upgrade information. The user must upgrade according to the prompt; otherwise, the App cannot be used. Follow the on-screen instructions to complete the upgrade.

Inverter Software Version Upgrade

- The inverter supports software upgrade via a U disk.
- Before using a U disk to upgrade the device, please contact the after-sales service center to obtain the software upgrade package and upgrade method.

10.2 Explanation of Terms

- **Overvoltage Category Definition**

- **Overvoltage Category I:** Equipment connected to circuits with measures to limit transient overvoltages to a relatively low level.
- **Overvoltage Category II:** Energy-consuming equipment supplied from a fixed electrical installation. This category includes appliances, portable tools, and other household and similar loads. If special requirements for reliability and suitability apply to such equipment, Overvoltage Category III is adopted.
- **Overvoltage Category III:** Equipment in fixed electrical installations where reliability and suitability must meet special requirements. This includes switching devices in fixed electrical installations and industrial equipment permanently connected to fixed electrical installations.
- **Overvoltage Category IV:** Equipment used at the origin of the electrical installation. This includes measuring instruments, upstream overcurrent protection devices, etc.

- **Damp Location Category Definition**

Environmental Parameters	Levels		
	3K3	4K2	4K4H
Temperature Range	0~+40°C	-33~+40°C	-33~+40°C
Humidity Range	5% to 85%	15% to 100%	4% to 100%

- **Environmental Category Definition:**

- **Outdoor Type Inverter:** Ambient air temperature range -25°C to +60°C, suitable for Pollution Degree 3 environment.
- **Indoor Type II Inverter:** Ambient air temperature range -25°C to +40°C, suitable for Pollution Degree 3 environment.
- **Indoor Type I Inverter:** Ambient air temperature range 0°C to +40°C, suitable for Pollution Degree 2 environment.

- **Pollution Degree Category Definition**

- **Pollution Degree 1:** No pollution or only dry, non-conductive pollution.
- **Pollution Degree 2:** Normally only non-conductive pollution occurs. Temporary conductivity caused by condensation must be expected, however.
- **Pollution Degree 3:** Conductive pollution occurs, or dry non-conductive pollution becomes conductive due to condensation.
- **Pollution Degree 4:** Persistent conductivity caused by conductive dust, rain, or snow.

10.3 Battery SN Code Meaning

*****2388*****

 11-14位

LXD10DSC0002

Digits 11-14 of the product SN code represent the production date code.
 The production date in the image above is 2023-08-08.

- Digits 11 and 12 represent the last two digits of the production year, e.g., 23 for the year 2023;
- Digit 13 represents the production month, e.g., 8 for August;
 Details are as follows:

Month	Jan~Sep	Oct	Nov	Dec
Month Code	1~9	A	B	C

- Digit 14 represents the production day, e.g., 8 for the 8th;
 Numbers are used preferentially, e.g., 1~9 for the 1st to 9th, A for the 10th, and so on. The letters I and O are not used to avoid confusion. Details are as follows:

Production Date	1	2	3	4	5	6	7	8	9
Code	1	2	3	4	5	6	7	8	9

Production Date	10	11	12	13	14	15	16	17	18
Code	A	B	C	D	E	F	G	H	J

Production Date	21	22	23	24	25	26	27	28	29
Code	M	N	P	Q	R	S	T	U	V

10.4 Safety Regulation Countries

No.	Safety Regulation Name	No.	Safety Regulation Name
Europe			
1	IT-CEI 0-21	56	IE-LV-72A
2	IT-CEI 0-16	57	IE-ESB-C&D(< 110kV)
3	DE LV with PV	58	IE-EirGrid-110kV
4	DE LV without PV	59	PT-D
5	DE-MV	60	EE
6	ES-A	61	NO
7	ES-B	62	FI-A
8	ES-C	63	FI-B
9	ES-D	64	FI-C
10	ES-island	65	FI-D
11	BE	66	UA-A1
12	FR-LV	67	UA-A2
13	FR-island-50Hz	68	EN 50549-1
14	FR-island-60Hz	69	EN 50549-2
15	type A-PL_V.1.1	70	DK-West-B-MVHV
16	type B-LV-PL_V.1.1	71	DK-East-B-MVHV
17	type C-PL_V.1.1	72	DK-West-C-MVHV
18	type D-PL_V.1.1	73	DK-East-C-MVHV
19	NL-16/20A	74	DK-West-D-MVHV
20	NL-A	75	DK-East-D-MVHV
21	NL-B	76	FR-Reunion
22	NL-C	77	BE-LV (>30kVA)
23	NL-D	78	BE-HV
24	SE-A	79	CH-B
25	SE MV	80	NI-G99-A
26	SK-A	81	NI-G99-B

No.	Safety Regulation Name	No.	Safety Regulation Name
27	SK-B	82	NI-G99-C
28	SK-C	83	NI-G99-D
29	HU	84	IE-LV-170kVA
30	CH-A	85	IE-MV&HV-200kVA
31	CY	86	DE-HV
32	GR	87	FR-MV
33	DK-West-A	88	CZ-A1/A2-09
34	DK-East-A	89	DE-EHV
35	DK-West-B	90	IE-EirGrid-400KV
36	DK-East-B	91	IE-EirGrid-220KV
37	AT < 1kV	92	IE-EirGrid-66KV
38	AT > 1kV	93	IE-ESB-B
39	BG	94	IE-ESB-D(≥ 110 kV)
40	Czech	95	type B-MV-PL_V.1.1
41	CZ-A1-09	96	GB-G99-A HV
42	CZ-A2-09	97	GB-G99-B LV
43	CZ-B1/B2-09	98	GB-G99-C LV
44	CZ-C	99	UA-B
45	CZ-D	100	UA-C
46	RO-A	101	UA-D
47	RO-B	102	UK-G98
48	RO-D	103	UK-G99-A LV
49	GB-G98	104	UK-G99-B LV
50	GB-G99-A LV	105	UK-G99-C LV
51	GB-G99-B HV	106	CZ-A1

No.	Safety Regulation Name	No.	Safety Regulation Name
52	GB-G99-C HV	107	UK-A-MV
53	GB-G99-D	108	UK-B-MV
54	NI-G98	109	UK-C-MV
55	IE-LV-16/25A	-	-
Global			
1	60Hz-Default	6	IEC 61727-60Hz
2	50Hz-Default	7	Warehouse
3	127Vac-60Hz-Default	8	IEC61727-480Vac-60Hz
4	127Vac-50Hz-Default	9	IEC61727-480Vac-50Hz
5	IEC 61727-50Hz		
Americas			
1	Argentina-220V-LV	38	LUMAPR-2024-220Vac-3P
2	US-208Vac	39	LUMAPR-2024-240Vac-3P
3	US-240Vac	40	Cayman
4	Mexico-220Vac	41	Brazil-220Vac
5	Mexico-440Vac	42	Brazil-208Vac
6	US-480Vac	43	Brazil-230Vac
7	US-208Vac-3P	44	Brazil-240Vac
8	US-220Vac-3P	45	Brazil-254Vac
9	US-240Vac-3P	46	Brazil-127Vac
10	US-CA-208Vac	47	Brazil-ONS
11	US-CA-240Vac	48	Barbados
12	US-CA-480Vac	49	Chile-BT
13	US-CA-208Vac-3P	50	Chile-MT-A
14	US-CA-220Vac-3P	51	Chile MT-B
15	US-CA-240Vac-3P	52	Colombia
16	US-HI-208Vac	53	Colombia<0.25MW-208Vac-1P

No.	Safety Regulation Name	No.	Safety Regulation Name
17	US-HI-240Vac	54	Colombia<0.25MW-120Vac-3P
18	US-HI-480Vac	55	IEEE 1547-208Vac
19	US-HI-208Vac-3P	56	IEEE 1547-220Vac
20	US-HI-220Vac-3P	57	IEEE 1547-240Vac
21	US-HI-240Vac-3P	58	IEEE 1547-230Vac
22	US-Kauai-208Vac	59	Colombia<0.25MW-127Vac-3P
23	US-Kauai-240Vac	60	Colombia>5MW
24	US-Kauai-480Vac	61	Mexico-127V
25	US-Kauai-208Vac-3P	62	Mexico-240V
26	US-Kauai-220Vac-3P	63	US-O&R-208Vac
27	US-Kauai-240Vac-3P	64	US-O&R-240Vac
28	US-ISO-NE-208Vac	65	US-O&R-480Vac
29	US-ISO-NE-240Vac	66	US-O&R-208Vac-3P
30	US-ISO-NE-480Vac	67	US-O&R-220Vac-3P
31	US-ISO-NE-208Vac-3P	68	US-O&R-240Vac-3P
32	US-ISO-NE-220Vac-3P	69	Brazil-277Vac
33	US-ISO-NE-240Vac-3P	70	Chile-BT ≤9MW
34	LUMAPR-2024-208Vac	71	Chile-MT ≤9MW
35	LUMAPR-2024-240Vac	72	Chile > 9MW
36	LUMAPR-2024-480Vac	73	Mexico-277Vac
37	LUMAPR-2024-208Vac-3P		
Oceania			
1	Australia-A	4	Newzealand
2	Australia-B	5	Newzealand:2015
3	Australia-C	6	NZ-GreenGrid
Asia			

No.	Safety Regulation Name	No.	Safety Regulation Name
1	China A	33	Israel-MV
2	China B	34	Israel-HV
3	China Higher Voltage	35	Vietnam
4	China Highest Voltage	36	Malaysia-LV
5	China Power Station	37	Malaysia-MV
6	China Shandong	38	DEWA-LV
7	China Hebei	39	DEWA-MV
8	China PCS	40	Saudi Arabia-220V-LV
9	Taiwan	41	JP-690Vac-50Hz
10	Hong Kong	42	JP-690Vac-60Hz
11	China Northeast	43	Srilanka-MV/HV
12	Thailand-MEA	44	IEC 61727-127Vac-50Hz
13	Thailand-PEA	45	IEC 61727-127Vac-60Hz
14	Mauritius	46	JP-550Vac-50Hz
15	Korea	47	JP-550Vac-60Hz
16	India	48	India-Higher
17	India-CEA	49	JP-220Vac-50Hz
18	Pakistan	50	JP-220Vac-60Hz
19	Philippines	51	Saudi Arabia-127V-LV
20	Philippines-127Vac	52	Srilanka-LV >1MW
21	JP-200Vac-50Hz	53	China-YN
22	JP-200Vac-60Hz	54	GB/T 29319-LV
23	JP-440Vac-50Hz	55	GB/T 29319-MV
24	JP-440Vac-60Hz	56	Philippines -277Vac
25	JP-420Vac-50Hz	57	JP-360Vac-50Hz
26	JP-420Vac-60Hz	58	JP-360Vac-60Hz
27	JP-480Vac-50Hz	59	JP-320Vac-50Hz
28	JP-480Vac-60Hz	60	JP-320Vac-60Hz

No.	Safety Regulation Name	No.	Safety Regulation Name
29	Srilanka-LV<1MW	61	JP-340Vac-50Hz
30	Singapore	62	JP-340Vac-60Hz
31	Israel-OG	63	JP-380Vac-50Hz
32	Israel-LV	64	JP-380Vac-60Hz
Africa			
1	Mauritius	5	Ghana-LV
2	South Africa-LV	6	Ghana-HV
3	South Africa-B-MV	7	South Africa-A3-LV
4	South Africa-C-MV	8	Nigeria

10.5 Australia Safety Regulations

For the Australian market, to comply with AS/NZS 4777.2:2020, please select from Australia A, Australia B, Australia C, or New Zealand. Please contact your local electricity grid operator on which Region to select.

Selecting a Region B should then automatically load all region B setpoints for volt-watt, volt-var, underfrequency, overfrequency, etc.

Volt-var response set-point values

Region	Default value	U1	U2	U3	U4
Australia A	Voltage	207V	220V	240V	258V
	Inverter reactive power level (Q) % of S_{rated}	44 % supplying	0%	0%	60 % absorbing
Australia B	Voltage	205V	220V	235V	255V
	Inverter reactive power level (Q) % of S_{rated}	30 % supplying	0%	0%	40 % absorbing

Region	Default value	U1	U2	U3	U4
Australia C	Voltage	215V	230V	240V	255V
	Inverter reactive power level (Q) % of S_{rated}	44 % supplying	0%	0%	60 % absorbing
New Zealand	Voltage	207V	220V	235V	244 V
	Inverter reactive power level (Q) % of S_{rated}	60 % supplying	0%	0%	60 % absorbing
Allowed range	Voltage	180 to 230 V	180 to 230 V	230 to 265 V	230 to 265 V
	Inverter reactive power level (Q) % of S_{rated}	30 to 60 % supplying	0%	0%	30 to 60 % absorbing

NOTE 1: Inverters may operate at a reactive power level with a range up to 100 % supplying or absorbing.

NOTE 2: Australia C parameter set is intended for application in isolated or remote power systems.

Volt-watt response default set-point values

Region	Default value	U3	U4
Australia A	Voltage	253V	260V
	Inverter maximum active power output level (P) % of S_{rated}	100%	20%
Australia B	Voltage	250V	260V
	Inverter maximum active power output level (P) % of S_{rated}	100%	20%
Australia C	Voltage	253V	260V

Region	Default value	U3	U4
	Inverter maximum active power output level (P) % of S_{rated}	100%	20%
New Zealand	Voltage	242 V	250V
	Inverter maximum active power output level (P) % of S_{rated}	100%	20%
Allowed range	Voltage	235 to 255 V	240 to 265 V
	Inverter maximum active power output level (P) % of S_{rated}	100%	20%

NOTE: Australia C parameter set is intended for application in isolated or remote power systems.

Passive anti-islanding voltage limit values

Protective function	Protective function limit	Trip delay time	Maximum disconnection time
Undervoltage 2 (V <<)	70 V	1 s	2 s
Undervoltage 1 (V <)	180 V	10 s	11 s
Overvoltage 1 (V >)	265 V	1 s	2 s
Overvoltage 2 (V >>)	275V	-	0.2 s

Upper connection and reconnection frequency (f_{URF})

Region	f_{URF}
Australia A	50.15 Hz

Australia B	50.15 Hz
Australia C	50.50 Hz
New Zealand	50.15 Hz

Setting steps:

Step 1: Set the safety code to Australia A/B/C/New Zealand on Quick Settings page based on actual needs.

Step 2: Set the frequency parameters accordingly.

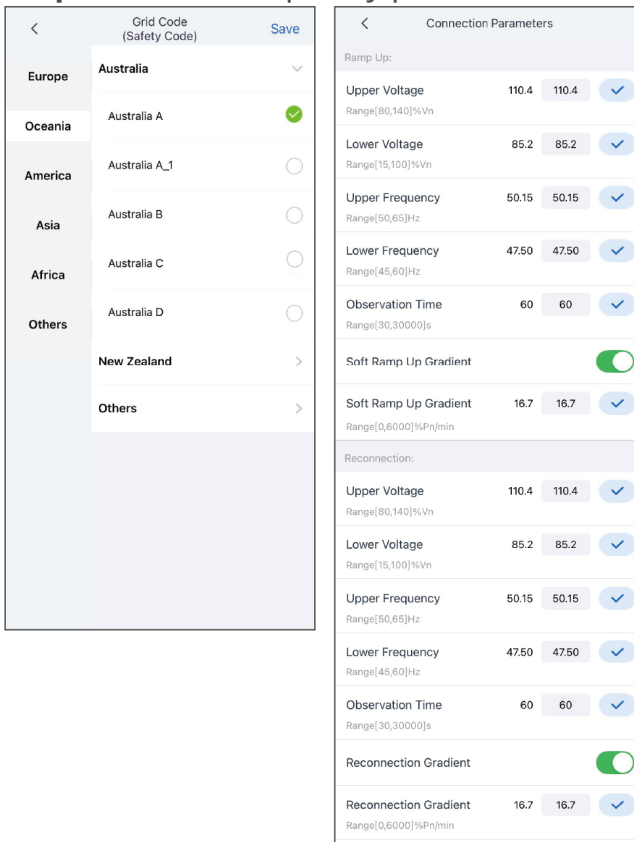

SLG00CON0144

Grid Code (Safety Code) Save

- Europe **Australia** ▾
- Oceania Australia A ○
- America Australia A_1 ○
- Asia **Australia B** ✓
- Africa Australia C ○
- Others Australia D ○
- New Zealand >
- Others >

Connection Parameters

Ramp Up:

Upper Voltage 110.4 110.4 ✓
Range[80,140]%Vn

Lower Voltage 85.2 85.2 ✓
Range[15,100]%Vn

Upper Frequency 50.15 50.15 ✓
Range[50,65]Hz

Lower Frequency 47.50 47.50 ✓
Range[45,60]Hz

Observation Time 60 60 ✓
Range[30,30000]s

Soft Ramp Up Gradient

Soft Ramp Up Gradient 16.7 16.7 ✓
Range[0,6000]%Pn/min

Reconnection:

Upper Voltage 110.4 110.4 ✓
Range[80,140]%Vn

Lower Voltage 85.2 85.2 ✓
Range[15,100]%Vn

Upper Frequency 50.15 50.15 ✓
Range[50,65]Hz

Lower Frequency 47.50 47.50 ✓
Range[45,60]Hz

Observation Time 60 60 ✓
Range[30,30000]s

Reconnection Gradient

Reconnection Gradient 16.7 16.7 ✓
Range[0,6000]%Pn/min

SLG00CON0146

Grid Code (Safety Code) Save

- Europe **Australia** ▾
- Oceania Australia A ○
- America Australia A_1 ○
- Asia Australia B ○
- Africa **Australia C** ✓
- Others Australia D ○
- New Zealand >
- Others >

Connection Parameters

Ramp Up:

Upper Voltage 110.4 110.4 ✓
Range[80,140]%Vn

Lower Voltage 85.2 85.2 ✓
Range[15,100]%Vn

Upper Frequency 50.50 50.50 ✓
Range[50,65]Hz

Lower Frequency 47.50 47.50 ✓
Range[45,60]Hz

Observation Time 60 60 ✓
Range[30,30000]s

Soft Ramp Up Gradient

Soft Ramp Up Gradient 16.7 16.7 ✓
Range[0,6000]%Pn/min

Reconnection:

Upper Voltage 110.4 110.4 ✓
Range[80,140]%Vn

Lower Voltage 85.2 85.2 ✓
Range[15,100]%Vn

Upper Frequency 50.50 50.50 ✓
Range[50,65]Hz

Lower Frequency 47.50 47.50 ✓
Range[45,60]Hz

Observation Time 60 60 ✓
Range[30,30000]s

Reconnection Gradient

Reconnection Gradient 16.7 16.7 ✓
Range[0,6000]%Pn/min

SLG00CON0145

11 Contact Details

GoodWe Technologies Co., Ltd.
No. 90 Zijin Rd., New District, Suzhou, China
en.goodwe.com
service@goodwe.com