

V2.2 2026-04-16

# Commercial and Industrial Smart Inverter

## ET Series 15-30kW

- Lynx C Series Commercial and Industrial Battery 60kWh
- BAT-C Series Commercial and Industrial Battery 61.4-112.6kWh
- BAT-S Series High-Voltage Battery 25.6-56.3kWh

## Solutions Manual

**GOODWE**

# Copyright Statement

## Copyright Statement

**Copyright© GoodWe Technologies Co., Ltd. 2026. All rights reserved.**

Without the authorization of GoodWe Technologies Co., Ltd., no part of this manual may be reproduced, disseminated, or uploaded to third-party platforms such as public networks in any form.

## **Trademark Authorization**

**GOODWE** and other GOODWE trademarks used in this manual are owned by GoodWe Technologies Co., Ltd. All other trademarks or registered trademarks mentioned in this manual belong to their respective owners.

## **NOTICE**

Due to product version upgrades or other reasons, the content of this document is updated periodically. Unless otherwise agreed, the content of this document cannot replace the safety precautions on the product label. All descriptions in this document are for guidance only.

# About This Manual

## Overview

This document primarily introduces the product information, installation wiring, configuration and commissioning, troubleshooting, and maintenance of the energy storage system composed of inverters, battery systems, and smart meters. Please read this manual carefully before installing and using the product to understand product safety information and familiarize yourself with the product's functions and features. The document may be updated periodically; please obtain the latest version of the materials and more product information from the official website.

## Applicable Model

The energy storage system includes the following products:

Product Type	Product Information	Description
Inverter	ET 15-30kW	Nominal output power 15kW to 30kW.
Battery system	Lynx C Series 60kWh Commercial & Industrial Battery System	Single cluster storage capacity 60kWh. Parallel cluster storage capacity up to 180kWh.
	BAT-S Series 25.6-56.3kWh High Voltage Battery	Single cluster storage capacity 25.6/30.7/35.8/40.9/46.0/51.2/56.3 kWh. Parallel cluster storage capacity up to 153.6/184.2/214.8/245.4/276.0/307.2 /337.8 kWh.

Product Type	Product Information	Description
	BAT-C Series 61.4-112.6kWh Commercial & Industrial Battery System	Single cluster storage capacity 61.4/92.1/102.4/112.6kWh.
Meter	GM3000	Monitoring module in the energy storage system, capable of detecting system operating voltage, current, and other information.
	GM330	
	GMK330	
smart dongle	WiFi/LAN Kit-20	Uploads system operating information to the monitoring platform via WiFi or LAN signal.
	LS4G Kit-CN, 4G Kit-CN, 4G Kit-CN-G20 or 4G Kit-CN-G21 (China only)	Uploads system operating information to the monitoring platform via 4G signal.
	Wi-Fi Kit	Uploads system operating information to the monitoring platform via WiFi signal.
	Ezlink3000	Connected to the main inverter in parallel system scenarios. Uploads system operating information to the monitoring platform via WiFi or LAN signal.

## Symbol Definition

 DANGER

Indicates a situation with a high potential hazard, which, if not avoided, will result in death or serious injury.

 WARNING

Indicates a situation with a moderate potential hazard, which, if not avoided, could result in death or serious injury.

 CAUTION

Indicates a situation with a low potential hazard, which, if not avoided, could result in moderate or minor injury.

NOTICE

Emphasizes or supplements the content, may provide tips or tricks for optimal product use, and can help you solve a problem or save you time.

## Table of Contents

1 Safety Precautions	15
1.1 General Safety	15
1.2 personnel requirements	15
1.3 System Safety	16
1.3.1 PV String Safety	18
1.3.2 Inverter Safety	19
1.3.3 Battery Safety	20
1.3.4 Smart Meter Safety	22
1.4 Safety Symbols and Certification Marks	23
1.5 EU Declaration of Conformity	24
1.5.1 Equipment with Wireless Communication Modules	24
1.5.2 Equipment without Wireless Communication Modules (Except Battery)	25
1.5.3 Battery	25
2 System Introduction	27
2.1 System Overview	27
2.2 Product Overview	31
2.2.1 Inverter	31
2.2.2 Battery	33
2.2.2.1 Lynx C Series 60kWh Commercial & Industrial Battery System	34
2.2.2.2 BAT-S Series 25.6-56.3kWh High Voltage Battery	35
2.2.2.3 BAT-C Series 61.4-112.6kWh Commercial & Industrial Battery	39

System	
2.2.3 Smart Meter	50
2.2.4 smart dongle	51
2.3 Supported Grid Types	52
2.4 System Working Mode	53
2.5 Features	64
3 Check and Storage	67
3.1 Check Before Receiving	67
3.2 deliverables	67
3.2.1 Inverter Deliverables	67
3.2.2 Batteries Deliverables	70
3.2.2.1 Lynx C Series 60kWh Commercial & Industrial Battery System	70
3.2.2.2 BAT-S Series 25.6-56.3kWh High Voltage Battery	74
3.2.2.3 BAT-C Series 61.4-112.6kWh Commercial & Industrial Battery System	78
3.2.3 Smart Meter Deliverables (GM3000)	79
3.2.4 Smart Meter Deliverables GM330 & GMK330	79
3.2.4.1 Attachment List	79
3.3 Storage	80
4 Installation	83
4.1 System Installation and Commissioning Procedure	83
4.2 Installation Requirements	83
4.2.1 Installation Environment Requirements	84

4.2.2 Installation Foundation Requirements	86
4.2.3 Installation Space Requirements	87
4.2.4 Tool Requirements	89
4.3 Equipment Handling	91
4.4 Installing the Inverter	95
4.5 Installing the Battery System	98
4.5.1 Open the Cabinet Door	99
4.5.2 Installing the Lynx C Series 60kWh Commercial & Industrial Battery System	100
4.5.3 Installing the BAT-S Series 25.6-56.3kWh High Voltage Battery	100
4.5.4 Installing the BAT-C Series 61.4-112.6kWh Commercial & Industrial Battery System	104
4.6 Installing the Smart Meter	106
5 System Wirings	108
5.1 System Wiring Electrical Block Diagram	108
5.2 Detailed System Wiring Diagram	111
5.2.1 Detailed System Wiring Diagram for Single Inverter	112
5.2.2 Detailed System Wiring Diagram for Parallel System	117
5.3 Preparing Materials	120
5.3.1 Preparing Breakers	121
5.3.2 Preparing Cables	123
5.3.3 Remove the Baffle Plate	127
5.4 Connecting the PE cable	129

5.4.1 Inverter Grounding	130
5.4.2 Battery System Grounding	130
5.5 Connecting the PV Cable	131
5.6 Connecting the Battery System Cables	133
5.6.1 With Lynx C Series 60kWh Commercial & Industrial Battery System	137
5.6.1.1 Introduction to Battery Cable Ports	137
5.6.1.2 Connecting the Power Cable between the Inverter and Battery	138
5.6.1.3 Connecting the Battery Communication Cable	142
5.6.1.4 Connecting the Internal Power Busbar of the Battery System	144
5.6.1.5 Connecting the Air Conditioner Power Cable for the Battery System	145
5.6.1.6 Connecting the Air Conditioner Drain Pipe for the Battery System	146
5.6.1.7 Turn On the Fire Protection Switch	146
5.6.1.8 Install the Baffle Plate	148
5.6.2 With BAT-S Series 25.6-56.3kWh High Voltage Battery	148
5.6.2.1 Connecting the Power Cable between the Inverter and Battery	149
5.6.2.2 Connecting the Power Cable between Batteries	151
5.6.2.3 Connecting the Communication Cable	152
5.6.3 With BAT-C Series 61.4-112.6kWh Commercial & Industrial Battery System	154
5.6.3.1 Introduction to Battery Cable Ports and System Wiring	155
5.6.3.2 Connecting the Power Cable between the Inverter and Battery	156
5.6.3.3 Connecting the Battery Communication Cable	157

5.6.3.4 Connecting the Battery Air Conditioner Cable	159
5.6.3.5 Install the Bottom Plate and Release the Emergency Stop Switch	160
5.7 Connecting the AC Cable	160
5.8 Connecting the Meter Cable	162
5.9 Connecting the Inverter Communication Cable	166
5.10 Connecting the Smart Dongle	173
6 System Commissioning	176
6.1 Check Before Power ON	176
6.2 Power ON	176
6.3 Indicators	178
6.3.1 Inverter Indicators	178
6.3.2 Battery Indicators	179
6.3.3 Smart Meter Indicator	181
6.3.4 Smart Dongle Indicator	182
6.4 Close the Cabinet Door	186
7 System Commissioning	188
7.1 SolarGo APP	188
7.1.1 App Introduction	188
7.1.1.1 Download and Install the App	188
7.1.1.2 Connection Methods	189
7.1.1.3 Login Interface Introduction	190
7.1.2 Connect Energy Storage Inverter (Bluetooth)	191

7.1.3 Energy Storage Inverter Interface Introduction	193
7.1.4 Set Communication Parameters	195
7.1.4.1 Set Privacy and Security Parameters	195
7.1.4.2 Set WLAN/LAN Parameters	198
7.1.4.3 Set RS485 Communication Parameters	200
7.1.4.4 Detect WLAN	200
7.1.5 System Quick Setup	201
7.1.5.1 System Quick Setup (Type 2)	202
7.1.6 Setting the Basic Information	208
7.1.6.1 Set Lightning Protection Alarm Function	208
7.1.6.2 Set Shadow Scan Function	209
7.1.6.3 Set Backup Power Parameters	210
7.1.6.4 Set Power Scheduling Parameters	212
7.1.7 Setting Advanced Parameters	215
7.1.7.1 Set DRED/Remote Shutdown/RCR/EnWG 14a Functions	215
7.1.7.2 Set Three-Phase Unbalanced Output	216
7.1.7.3 Set BACK-UP N and PE Relay Switch	217
7.1.7.4 Set Grid-Connected Power Limitation Parameters	218
7.1.7.4.1 Set Grid-Connected Power Limitation Parameters (General)	218
7.1.7.4.2 Set Grid-Connected Power Limitation Parameters (Australia)	219
7.1.7.5 Set Arc Detection Function	221
7.1.7.6 Set PV Connection Mode	221

7.1.7.7 Set Unbalanced Voltage Output Function.....	223
7.1.7.8 Set Power Scheduling Response Parameters.....	223
7.1.7.9 Set Power Scheduling Parameters.....	225
7.1.7.10 Restore Factory Settings.....	226
7.1.8 Set Battery Functions.....	227
7.1.8.1 Set Lithium Battery Parameters.....	227
7.1.9 Set Custom Safety Regulation Parameters.....	231
7.1.9.1 Set Reactive Power Curve.....	232
7.1.9.2 Set Active Power Curve.....	236
7.1.9.3 Set Grid Protection Parameters.....	242
7.1.9.4 Set Grid Connection Parameters.....	243
7.1.9.5 Set Voltage Fault Ride-Through Parameters.....	245
7.1.9.6 Set Frequency Fault Ride-Through Parameters.....	247
7.1.10 Export Parameters.....	247
7.1.10.1 Export Safety Regulation Parameters.....	247
7.1.10.2 Export Log Parameters.....	248
7.1.11 Set Generator/Load Control Parameters.....	249
7.1.11.1 Set Load Control Parameters.....	249
7.1.11.2 Set Generator Parameters.....	251
7.1.12 Set Meter Parameters.....	254
7.1.12.1 Bind/Unbind Meter.....	254
7.1.12.2 Meter/CT Auxiliary Detection.....	256

7.1.13 Device Maintenance	256
7.1.13.1 View Firmware Information/Firmware Upgrade	257
7.1.13.1.1 Conventional Firmware Upgrade	257
7.1.13.1.2 One-Click Firmware Upgrade	258
7.1.13.1.3 Automatic Firmware Upgrade	259
7.1.13.1.4 View Firmware Information	260
7.1.13.2 Change Login Password	261
8 System Commissioning and Power Station Monitoring	263
8.1 Setting Inverter Parameters via App	263
8.1.1 Download and Install the SEMS+ App	263
8.2 Monitoring Power Station via SEMS+ WEB	264
9 Maintenance	265
9.1 Power OFF the System	265
9.2 Removing the Equipment	266
9.3 Disposing of the Equipment	267
9.4 Routine Maintenance	267
9.5 fault	268
9.5.1 Viewing Fault/Alarms Information	268
9.5.2 Fault Information and Troubleshooting	269
9.5.2.1 System Fault	269
9.5.2.2 Inverter Fault	271
9.5.2.2.1 Troubleshooting (Fault Codes F01-F40)	271

9.5.2.2.2 Troubleshooting (Fault Codes F41-F80)	289
9.5.2.2.3 Troubleshooting (Fault Codes F81-F121)	298
9.5.2.2.4 Troubleshooting (Fault Codes F122-F163)	310
9.5.2.2.5 Troubleshooting Fault Phenomena	319
9.5.2.3 Battery Fault	337
9.5.3 Post-Fault Clearance Handling	352
9.5.3.1 Clear AFCI Fault Warning	352
10 technical parameter	354
10.1 Smart Meter Technical Data	354
10.1.1 GM330	354
10.1.2 GM3000	355
10.1.3 GMK330	356
10.2 Smart Dongle Technical Data	357
10.2.1 4G Kit-CN-G21	357
10.2.2 4G Kit-CN-G20	358
10.2.3 WiFi/LAN Kit-20	359
10.2.4 Ezlink3000	360
11 Appendix	361
11.1 FAQ	361
11.1.1 How to conduct auxiliary detection for smart meters/CT?	361
11.1.2 How to Upgrade the Device Version	361
11.2 Abbreviations	362

11.3 Explanation of Terms.....	365
11.4 Meaning of Battery SN Code.....	366
11.5 Safety Regulation Countries.....	367

# 1 Safety Precautions

The Safety Precautions information contained in this document must always be observed when operating the device.

## WARNING

The equipment has been strictly designed and tested in compliance with safety regulations. However, as electrical equipment, relevant safety instructions must be followed before performing any operations. Improper operation may result in serious injury or property damage.

## 1.1 General Safety

### NOTICE

- Due to product version upgrades or other reasons, the document content will be updated periodically. Unless otherwise agreed, the document content cannot replace the safety precautions on product labels. All descriptions in the document are for guidance only.
- Please read this document carefully before installing the device to understand the product and precautions.
- All operations on the device must be performed by professional, qualified electrical technicians who are familiar with the relevant standards and safety regulations at the project location.
- When operating the device, use insulated tools and wear personal protective equipment to ensure personal safety. When handling electronic components, wear anti-static gloves, anti-static wrist straps, anti-static clothing, etc., to protect the device from electrostatic damage.
- Unauthorized disassembly or modification may cause device damage, and such damage is not covered by the warranty.
- Device damage or personal injury caused by not installing, using, or configuring the device according to this document or the corresponding user manual is beyond the manufacturer's liability. For more product warranty information, please visit the official website: <https://en.goodwe.com/warrantyrelated.html>.

## 1.2 personnel requirements

### NOTICE

To ensure safety, compliance, and efficiency throughout the entire process of equipment transportation, installation, wiring, operation, and maintenance, all tasks must be performed by professional or qualified personnel.

1. Professional or qualified personnel include:
  - Personnel who have mastered knowledge of equipment working principles, system architecture, risks and hazards, and have received professional operation training or possess extensive practical experience.
  - Personnel who have received relevant technical and safety training, possess certain operational experience, are aware of the potential dangers specific tasks may pose to themselves, and can take protective measures to minimize risks to themselves and others.
  - Qualified electrical technicians who meet the regulatory requirements of the country/region where they are located.
  - Personnel holding a degree in electrical engineering/an advanced diploma in electrical discipline or equivalent/professional qualification in the electrical field, and with at least 2/3/4 years of experience in testing and regulatory work using electrical equipment safety standards.
2. Personnel involved in special tasks such as electrical work, work at heights, and operation of special equipment must hold valid qualification certificates required by the location of the equipment.
3. Operation of medium-voltage equipment must be performed by certified high-voltage electricians.
4. Replacement of equipment and components is only permitted to be performed by authorized personnel.

## 1.3 System Safety



- Before making electrical connections, disconnect all upstream switches of the equipment to ensure the equipment is powered off. Live operation is strictly prohibited, otherwise hazards such as electric shock may occur.
- To prevent personal injury or equipment damage caused by live operation, a circuit breaker must be added to the voltage input side of the equipment.
- All operations including transportation, storage, installation, operation, use, and maintenance must comply with applicable laws, regulations, standards, and specifications.
- The specifications of cables and components used for electrical connections must comply with local laws, regulations, standards, and specifications.
- Please use the cable connectors provided in the box to connect the equipment cables. If other models of connectors are used, any resulting equipment damage is not within the responsibility of the equipment manufacturer.
- Ensure all cable connections on the equipment are correct, secure, and not loose. Improper wiring may cause poor contact or damage the equipment.
- The protective ground wire of the equipment must be securely connected.
- To protect the equipment and its components from damage during transportation, ensure the transport personnel are professionally trained. Record the operation steps during transportation and keep the equipment balanced to avoid dropping.
- The equipment is heavy. Please allocate personnel according to the equipment's weight to prevent it from exceeding the human body's carrying capacity, which could cause injury from dropping.
- Ensure the equipment is placed stably and not tilted. The equipment tipping over may cause equipment damage and personal injury.



- During equipment installation, avoid putting weight on the wiring terminals, as this may cause terminal damage.
- If the cable is subjected to excessive tension, it may lead to poor connection. When wiring, leave a certain length of cable slack before connecting it to the equipment's wiring port.
- Cables of the same type should be bundled together. Cables of different types should be routed at least 30mm apart and must not be intertwined or cross-routed.
- Using cables in high-temperature environments may cause insulation aging and damage. Maintain a distance of at least 30mm between cables and heat-generating components or the periphery of heat source areas.

### **1.3.1 PV String Safety**

## WARNING

- Ensure the component frame and mounting system are properly grounded.
- After completing the DC cable connections, ensure the cable connections are tight and secure, with no looseness. Improper wiring may lead to poor contact, high impedance, and damage to the inverter.
- Use a multimeter to measure the positive and negative poles of the DC cables to ensure correct polarity (no reverse connection) and that the voltage is within the permissible range.
- Use a multimeter to measure the DC cables to ensure correct polarity (no reverse connection); the voltage should be lower than the maximum DC input voltage. Damage caused by reverse connection and overvoltage is not covered by the equipment manufacturer's warranty.
- The PV string output does not support grounding. Before connecting the PV string to the inverter, ensure the minimum insulation resistance to ground of the PV string meets the minimum insulation resistance requirement ( $R = \text{Max. Input Voltage (V)} / 30\text{mA}$ ).
- Do not connect the same PV string to multiple inverters, as this may cause inverter damage.
- The photovoltaic modules used with the inverter must comply with IEC 61730 Class A standards.
- When the PV string input voltage or input current is high, it may cause the inverter output power to derate.

### 1.3.2 Inverter Safety

## WARNING

- Ensure that the voltage and frequency at the grid connection point comply with the inverter's grid-connection specifications.
- It is recommended to add protective devices such as circuit breakers or fuses on the AC side of the inverter. The rating of the protective devices should be greater than 1.25 times the maximum AC output current of the inverter.
- If the inverter triggers an arc fault alarm less than 5 times within 24 hours, the alarm can be cleared automatically. After the 5th arc fault alarm, the inverter will shut down for protection. The inverter can only resume normal operation after the fault is cleared.
- If the photovoltaic system is not equipped with a battery, it is not recommended to use the BACK-UP function, as it may cause a risk of system power outage.
- Changes in grid voltage and frequency may cause the inverter output power to derate.

### 1.3.3 Battery Safety

## DANGER

- Before operating the equipment in the system, ensure that the equipment is powered off to avoid the risk of electric shock. During equipment operation, strictly adhere to all safety precautions in this manual and the safety labels on the equipment.
- Do not disassemble, modify, or repair the battery or control box without official authorization from the equipment manufacturer. Otherwise, there may be a risk of electric shock or equipment damage, and the resulting losses are beyond the manufacturer's liability.
- Do not impact, pull, drag, squeeze, or step on the equipment, and do not place the battery in fire, otherwise the battery may explode.
- Do not place the battery in high-temperature environments. Ensure that there are no heat sources near the battery and that it is not exposed to direct sunlight. When the ambient temperature exceeds 60°C, a fire may occur.
- If the battery or control box has obvious defects, cracks, damage, or other conditions, do not use it. Battery damage may cause electrolyte leakage.
- Do not move the battery system while it is operating. If you need to replace or add batteries, contact the after-sales service center.
- Battery short circuit may cause personal injury. The instantaneous high current from a short circuit can release a large amount of energy and may cause a fire.
- The battery DC circuit breaker should comply with the requirements of the AS/NZS 5139 standard.

## WARNING

- Battery current may be affected by some factors, such as: temperature, humidity, weather conditions, etc., which may cause battery current limiting, affecting load capacity.
- If the battery cannot start, please contact the after-sales service center as soon as possible. Otherwise, the battery may be permanently damaged.
- Please perform regular inspection and maintenance on the battery according to the battery's maintenance requirements.

## Emergency Response Measures

- Battery electrolyte leakage

If the battery module leaks electrolyte, avoid contact with the leaked liquid or gas. Electrolyte is corrosive, and contact may cause skin irritation and chemical burns. If you accidentally come into contact with the leaked substance, please perform the following actions:

- inhalation: Evacuate from the contaminated area and seek medical help immediately.
- Eye contact: Rinse with clean water for at least 15 minutes and seek medical help immediately.
- Skin contact: Thoroughly wash the affected area with soap and water and seek medical help immediately.
- Ingestion: Induce vomiting and seek medical assistance immediately.

- Fire

- When the battery temperature exceeds 150°C, there is a risk of fire, and the battery may release toxic and harmful gases after catching fire.
- To prevent fire, ensure that there are carbon dioxide, Novec1230, or FM-200 fire extinguishers near the equipment.
- When extinguishing the fire, do not use ABC dry powder fire extinguishers. Firefighters must wear protective clothing and self-contained breathing apparatus.

- Battery triggers fire protection

For batteries equipped with fire protection function, after the fire protection function is triggered, perform the following actions:

- Immediately cut off the main power switch to ensure no current passes through the battery system.
- Conduct a preliminary visual inspection of the battery for any damage, deformation, leakage, or odor. Check the battery casing, connectors, and cables.
- Use a temperature sensor to detect the battery and its ambient temperature to ensure no risk of overheating.
- Isolate and mark the damaged battery, and dispose of it properly according to local regulations.

### 1.3.4 Smart Meter Safety









## WARNING















If the grid voltage fluctuation exceeds 265V, long-term overvoltage operation may cause damage to the electric meter. It is recommended to add a fuse with a rated current of 0.5A on the voltage input side of the meter to protect it.

## 1.4 Safety Symbols and Certification Marks

### DANGER

- After the equipment is installed, the labels and warning signs on the enclosure must remain clearly visible. Do not cover, alter, or damage them.
- The enclosure warning label descriptions provided below are for reference only. Please refer to the actual labels used on the equipment.

No.	Symbol	Meaning
1		Potential hazard exists during equipment operation. Take precautions when operating the equipment.
2		High voltage hazard. High voltage is present during equipment operation. Ensure the equipment is powered off before performing any operations.
3		Inverter surface is hot. Do not touch during operation to avoid burns.
4		Use the equipment properly. Use under extreme conditions carries a risk of explosion.
5		Battery contains flammable materials. Beware of fire.
6		Equipment contains corrosive electrolyte. Avoid contact with leaked electrolyte or vapor.
7		Delayed discharge. After powering off the equipment, wait for 5 minutes until it is completely discharged.
8		Keep the equipment away from open flames or ignition sources.

No.	Symbol	Meaning
9		Keep the equipment out of reach of children.
10		Use the equipment properly. Use under extreme conditions carries a risk of explosion.
11		Battery contains flammable materials. Beware of fire.
12		Do not lift the equipment after the battery system wiring is completed or while the battery system is operating.
13		Do not extinguish with water.
14		Read the product manual carefully before operating the equipment.
15		Wear personal protective equipment during installation, operation, and maintenance.
16		Do not dispose of the equipment as household waste. Dispose of the equipment according to local laws and regulations, or return it to the equipment manufacturer.
17		Do not directly disconnect or plug/unplug the DC terminals while the equipment is operating.
18		Grounding point.
19		Recycling symbol.
20		CE certification mark.
21		TUV mark.
22		RCM mark.

## 1.5 EU Declaration of Conformity

### **1.5.1 Equipment with Wireless Communication Modules**

The following directives apply to equipment with wireless communication modules that can be sold on the European market:

- Radio Equipment Directive 2014/53/EU (RED)
- Restrictions of Hazardous Substances Directive 2011/65/EU and (EU) 2015/863 (RoHS)
- Waste Electrical and Electronic Equipment 2012/19/EU
- Registration, Evaluation, Authorization and Restriction of Chemicals (EC) No 1907/2006 (REACH)

### **1.5.2 Equipment without Wireless Communication Modules (Except Battery)**

Equipment without wireless communication modules that can be sold in the European market must meet the requirements of the following directives:

- Electromagnetic compatibility Directive 2014/30/EU (EMC)
- Electrical Apparatus Low Voltage Directive 2014/35/EU (LVD)
- Restrictions of Hazardous Substances Directive 2011/65/EU and (EU) 2015/863 (RoHS)
- Waste Electrical and Electronic Equipment 2012/19/EU
- Registration, Evaluation, Authorization and Restriction of Chemicals (EC) No 1907/2006 (REACH)

### **1.5.3 Battery**

Batteries that can be sold on the European market meet the requirements of the following directives:

- Electromagnetic compatibility Directive 2014/30/EU (EMC)
- Electrical Apparatus Low Voltage Directive 2014/35/EU (LVD)
- Restrictions of Hazardous Substances Directive 2011/65/EU and (EU) 2015/863 (RoHS)\*<sup>1</sup>
- Regulation (EU) 2023/1542 Article 12 - Safety of stationary battery energy storage systems
- Regulation (EU) 2023/1542 Article 10 - Performance and durability requirements

for rechargeable industrial batteries, LMT batteries and electric vehicle batteries

- Regulation (EU) 2023/1542 Article 14 - Information on the state of health and expected lifetime of batteries
- Waste Electrical and Electronic Equipment 2012/19/EU
- Registration, Evaluation, Authorization and Restriction of Chemicals (EC) No 1907/2006 (REACH)

\*1: Our company's battery products meet the hazardous substance limit requirements stipulated by this regulation.

More EU Declarations of Conformity are available on the [official website](#).

# 2 System Introduction

## 2.1 System Overview

The Commercial & Industrial Smart Inverter Solution integrates devices such as inverters, Battery, Smart Meter, and smart communication sticks. It converts solar energy into electrical power within the photovoltaic system to meet commercial and industrial electricity demands. The energy IoT devices in the system manage electrical appliances by identifying the overall power situation in the system, thereby intelligently managing power for supplying loads, storing it in the Battery, or exporting it to the grid.

### WARNING

- Select the battery model according to the inverter and battery matching list. For requirements regarding batteries used in the same system, such as whether models can be mixed or capacities must be consistent, please refer to the user manual of the corresponding battery model or contact the battery manufacturer for relevant requirements. Inverter and battery compatibility list: [https://en.goodwe.com/Ftp/EN/Downloads/User%20Manual/GW\\_Battery%20Compatibility%20Overview-EN.pdf](https://en.goodwe.com/Ftp/EN/Downloads/User%20Manual/GW_Battery%20Compatibility%20Overview-EN.pdf).
- Due to product version upgrades or other reasons, document content is updated periodically. For the compatibility relationship between inverters and IoT products, please refer to: [https://en.goodwe.com/Ftp/EN/Downloads/User%20Manual/GW\\_Compatibility-list-of-GoodWe-inverters-and-IoT-products-EN.pdf](https://en.goodwe.com/Ftp/EN/Downloads/User%20Manual/GW_Compatibility-list-of-GoodWe-inverters-and-IoT-products-EN.pdf).
- The photovoltaic system is not suitable for connecting devices that rely on stable power supply, such as life-sustaining medical equipment. Please ensure that system power failure does not cause personal injury.
- If a battery is not configured in the photovoltaic system, using the BACK-UP function is not recommended, as it may cause a system power failure risk.
- The BACK-UP port does not support connection to autotransformers or isolation transformers.
- Battery current may be affected by factors such as temperature, Humidity, weather conditions, etc., which may lead to battery current limiting and affect

 **WARNING**

load-carrying capacity.

- The inverter has UPS functionality with a switching time of <10ms. Please ensure the BACK-UP Loads capacity is less than the inverter's rated power. Otherwise, the UPS function may fail during a grid power outage.
- If a battery is not configured in the photovoltaic system, using the BACK-UP function is not recommended, as it may cause a system power failure risk.
- For detailed networking and wiring schemes for various scenarios, please refer to: Detailed System Wiring Diagram.
- When the inverter is in off-grid mode, it can power normal household loads. However, the following loads need to be restricted, such as:
  - inductive load: inductive load power < 0.4 times the inverter's rated output power.
  - Capacitive load: total power  $\leq 0.66 \times$  inverter rated output power.
  - The inverter does not support half-wave loads. Half-wave loads: Some old or non-EMC compliant appliances (such as hair dryers, small heaters using half-wave rectification) may not work properly.
- In a system where the inverter operates completely off-grid, if the battery experiences prolonged low sunlight or rainy weather and cannot be replenished in time, it may lead to over-discharge, causing battery performance degradation or damage. To ensure long-term stable system operation, avoid completely draining the battery. Recommended measures are as follows:
  - During off-grid operation, set the minimum SOC protection threshold. It is recommended to set the off-grid battery SOC lower limit to 30%.
  - When the SOC approaches the protection threshold, the system will automatically enter load-limiting or protection mode.
  - If there is insufficient sunlight for several consecutive days and the battery SOC is too low, promptly replenish the battery using external energy sources (such as a generator or grid-assisted charging).
  - Regularly check the battery status to ensure it operates within a safe range.
  - It is recommended to fully charge and discharge the battery once every six months to calibrate the SOC accuracy.

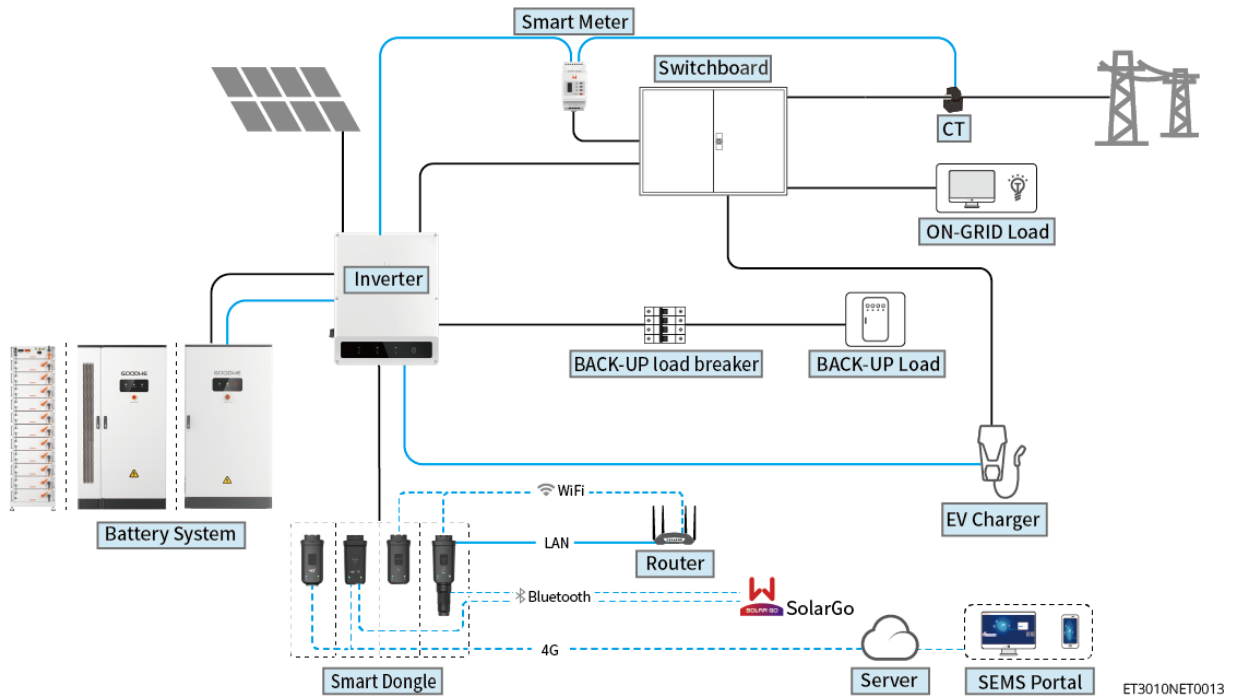

ET3010NET0013

Device Type	Model	Description
Inverter	GW15K-ET GW20K-ET GW25K-ET GW29.9K-ET GW30K-ET	<ul style="list-style-type: none"> <li>• Supports up to 4 inverters to form a parallel system.</li> <li>• Battery ready models do not support forming a parallel system when the battery function is not activated.</li> <li>• Only machines with the same AC output voltage can form a parallel system.</li> <li>• In coupling scenarios, using a dual meter can simultaneously monitor grid-connected inverter power generation and load power consumption. The following version requirements must be met:               <ul style="list-style-type: none"> <li>• Inverter ARM software version 15.441 and above.</li> <li>• Inverter DSP software version 11.11060 and above.</li> <li>• SolarGo version 6.9.0 and above.</li> </ul> </li> </ul>

Device Type	Model	Description
Battery system	GW60KWH-D-10 GW60KWH-D-10(without expansion cabinet)	The system supports up to 3 clusters of battery systems in parallel.
	GW25.6-BAT-I-G10 GW30.7-BAT-I-G10 GW35.8-BAT-I-G10 GW40.9-BAT-I-G10 GW46.0-BAT-I-G10 GW51.2-BAT-I-G10 GW56.3-BAT-I-G10	<ul style="list-style-type: none"> <li>• Supports up to 6 clusters of battery systems in parallel.</li> <li>• Battery systems of different models cannot be mixed and used in parallel.</li> </ul>
	GW61.4-BAT-AC-G10 GW92.1-BAT-AC-G10 GW102.4-BAT-AC-G10 GW112.6-BAT-AC-G10	Supports only a single cluster.
Smart Meter	<ul style="list-style-type: none"> <li>• GM3000</li> <li>• GM330</li> <li>• GMK330</li> </ul>	<ul style="list-style-type: none"> <li>• GM3000: Included with the inverter, CT cannot be replaced, CT ratio: 120A: 40mA</li> <li>• GM330: CT can be purchased from GoodWe or independently, CT ratio requirement: nA: 5A <ul style="list-style-type: none"> <li>◦ nA: CT primary side input current, n ranges from 200 to 5000</li> <li>◦ 5A: CT secondary side output current</li> </ul> </li> <li>• GMK330: CT shipped with the meter, CT ratio: <ul style="list-style-type: none"> <li>◦ 120A: 40mA</li> <li>◦ 200A: 50mA (Brazil only)</li> </ul> </li> </ul>

Device Type	Model	Description
smart dongle	<ul style="list-style-type: none"> <li>WiFi/LAN Kit-20</li> <li>Wi-Fi Kit</li> <li>LS4G Kit-CN, 4G Kit-CN, 4G Kit-CN-G20 or 4G Kit-CN-G21 (China only)</li> <li>Ezlink3000</li> </ul>	<ul style="list-style-type: none"> <li>For single unit, use WiFi/LAN Kit-20, Wi-Fi Kit, LS4G Kit-CN, 4G Kit-CN, 4G Kit-CN-G20, or 4G Kit-CN-G21 modules. If using WiFi/LAN Kit-20 to replace Wi-Fi Kit, upgrade the inverter ARM firmware version to 08.401 or above before switching to WiFi/LAN Kit-20.</li> <li>In parallel systems, only the master inverter needs to be connected to Ezlink3000, slave inverters do not require communication modules. Ezlink3000 firmware version must be 04 or above.</li> </ul>

## 2.2 Product Overview

### 2.2.1 Inverter

In a photovoltaic system, the Inverter controls and optimizes the energy flow through an integrated energy management system. It can supply the electricity generated by the PV system to loads, store it in batteries, or export it to the grid.

#### NOTICE

Inverters of different power ranges may vary in appearance; please refer to the actual product.

No.	model	Nominal output power	Nominal output voltage	Number of battery ports
1	GW15K-ET	15kW	380/400V, 3L/N/PE	1
2	GW20K-ET	20kW		1

No.	model	Nominal output power	Nominal output voltage	Number of battery ports
3	GW25K-ET	25kW		2
4	GW29.9K-ET	29.9kW		2
5	GW30K-ET	30kW		2

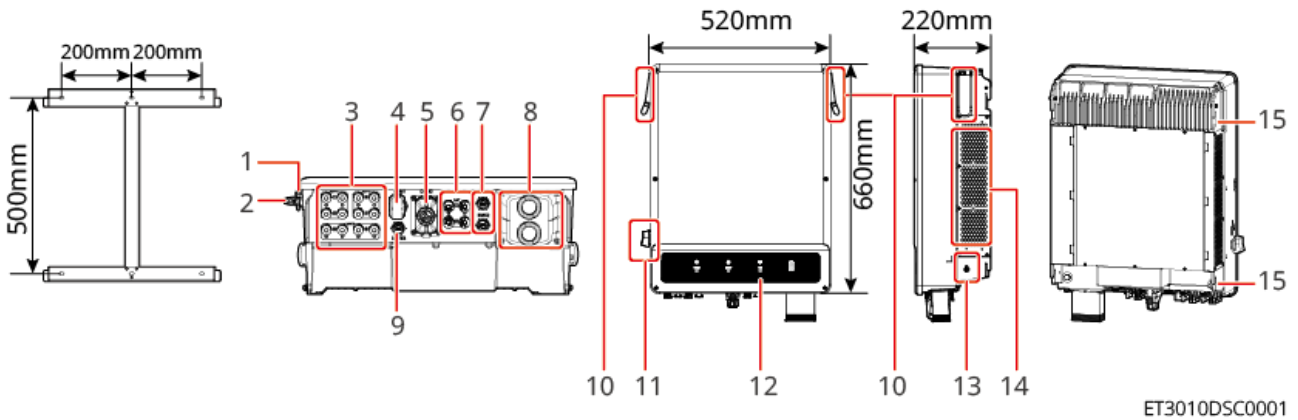

## Component Introduction

No.	Part/Silk Screen	Description
1	DC switch lock hole	Australia only.
2	DC Switch	Controls the connection or disconnection of the DC input.
3	PV input terminals	Can connect PV module DC input cables. <ul style="list-style-type: none"> <li>• GW15K-ET, GW20K-ET, GW12KL-ET x 2</li> <li>• GW25K-ET, GW29.9K-ET, GW30K-ET, GW18KL-ET x 3</li> </ul>
4	Communication module port	Can connect communication modules, supports connection of 4G, Wi-Fi/LAN modules.
5	Communication port	Connect communication cable, supports communication with DRED, Remote Shutdown, Rapid Shutdown, RCR, EMS, and generator.

6	Battery connection port	Connect battery DC cables. <ul style="list-style-type: none"> <li>• GW15K-ET, GW20K-ET x 1</li> <li>• GW25K-ET, GW29.9K-ET, GW30K-ET x 2</li> </ul>
7	BMS communication port	Connect battery communication cable. <ul style="list-style-type: none"> <li>• GW15K-ET, GW20K-ET x 1</li> <li>• GW25K-ET, GW29.9K-ET, GW30K-ET x 2</li> </ul>
8	AC port	Connect AC cables, ON-GRID and BACK-UP ports.
9	METER communication port	Connect smart meter.
10	Handle	For carrying the inverter.
11	indicator	Indicates the working status of the inverter.
12	Grounding terminal	Connect the chassis protective ground wire.
13	Fan	Inverter heat dissipation.
14	Inverter mounting slot	For mounting and locking the inverter.

### Australian Junction Box Dimensions

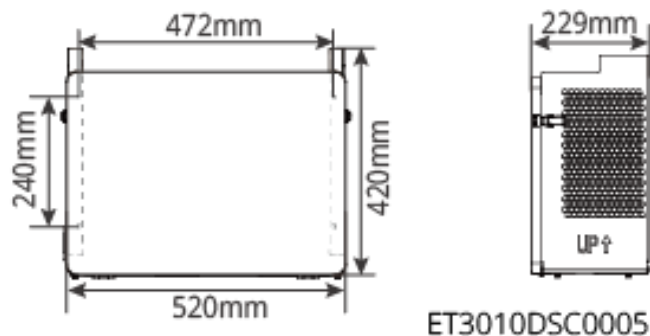

### 2.2.2 Battery

The battery system consists of a PCU and a PACK.

The battery system can store and release electrical energy according to the requirements of the photovoltaic energy storage system. The input and output ports of this energy storage system are both high-voltage direct current.

**NOTICE**

- After a single battery cabinet is installed, expansion by adding PACKs is not supported.
- Within one year of installation, the BAT series battery system can be expanded by adding battery cabinets of the same model and part number. For details, please consult after-sales service.

**2.2.2.1 Lynx C Series 60kWh Commercial and Industrial Battery System**

No.	model	Rated Capacity (kWh)	Includes AC Cabinet
1	GW60KWH-D-10	60	Yes
2	GW60KWH-D-10(without expansion cabinet)	60	No

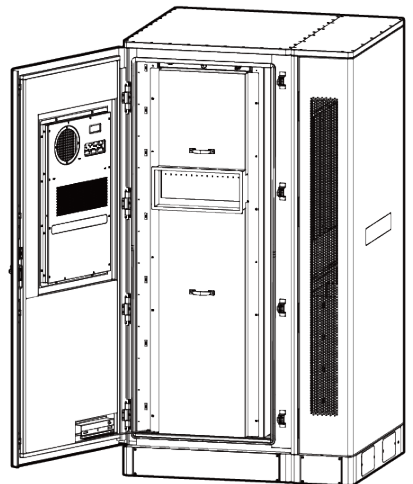
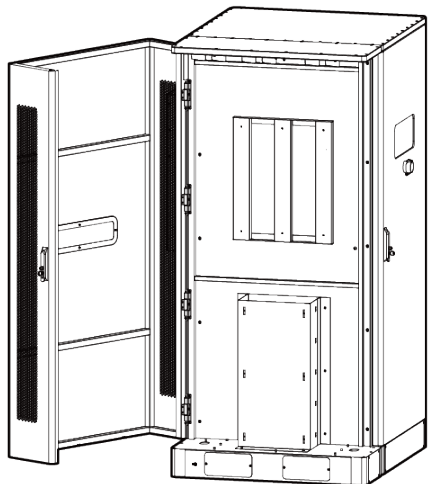
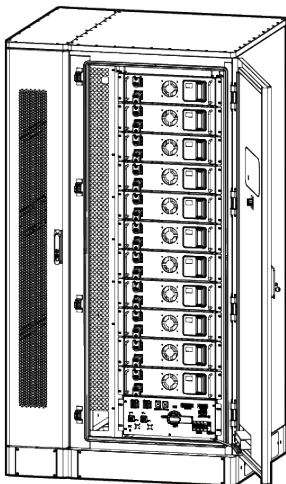
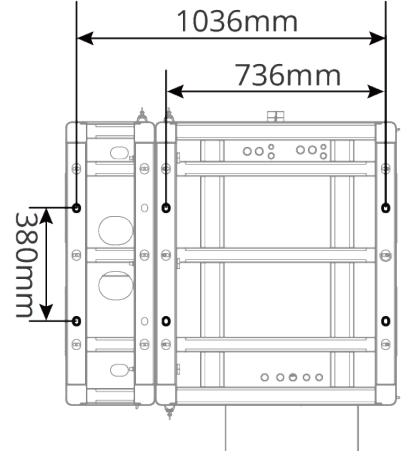
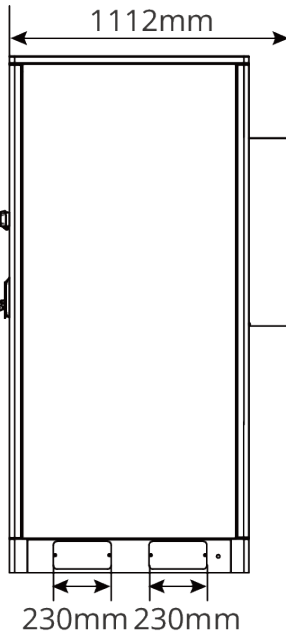
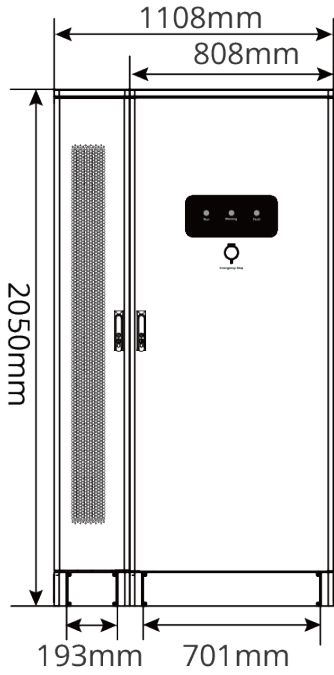

LXC6010DSC0001

**2.2.2.2 BAT-S Series 25.6-56.3kWh High Voltage Battery**

No.	model	PACK Quantity	Rated Capacity (kWh)
1	GW25.6-BAT-I-G10	5	25.6
2	GW30.7-BAT-I-G10	6	30.7
3	GW35.8-BAT-I-G10	7	35.8
4	GW40.9-BAT-I-G10	8	40.9

No.	model	PACK Quantity	Rated Capacity (kWh)
5	GW46.0-BAT-I-G10	9	46.0
6	GW51.2-BAT-I-G10	10	51.2
7	GW56.3-BAT-I-G10	11	56.3

## Dimension Description

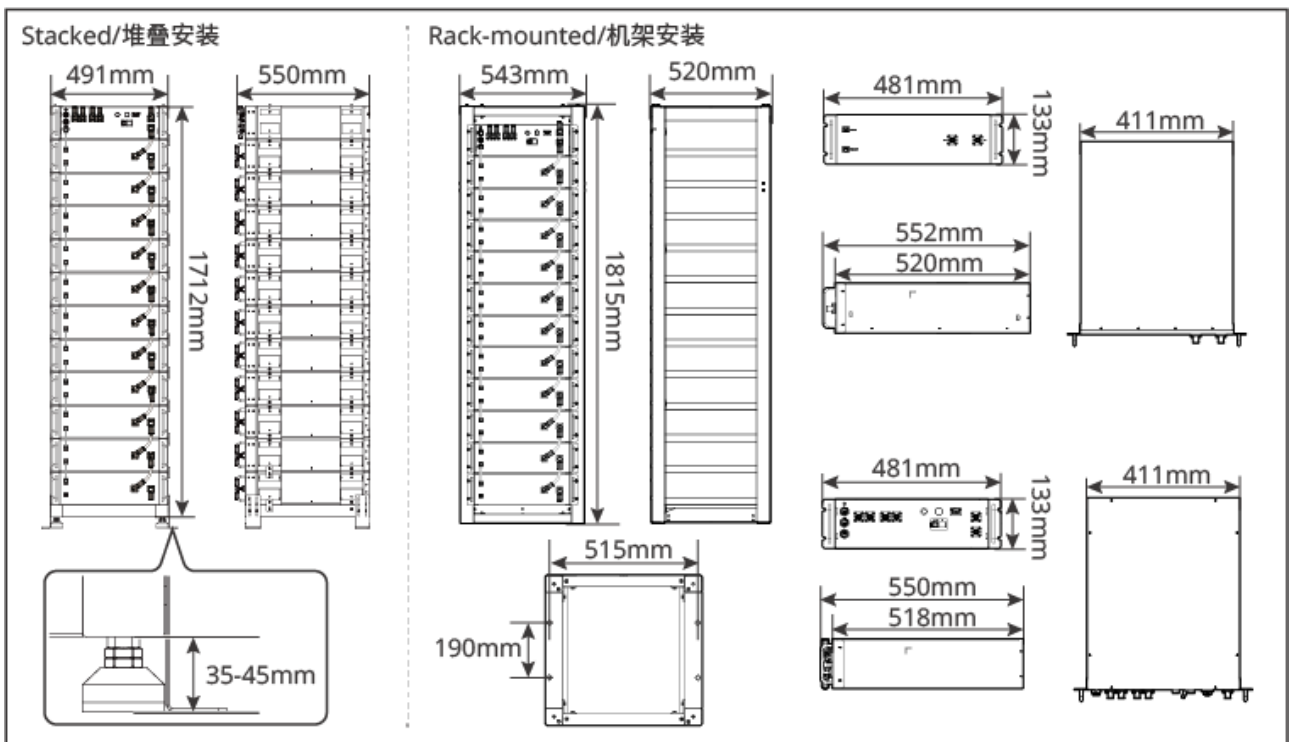

BAT10DSC0007

## Component Introduction

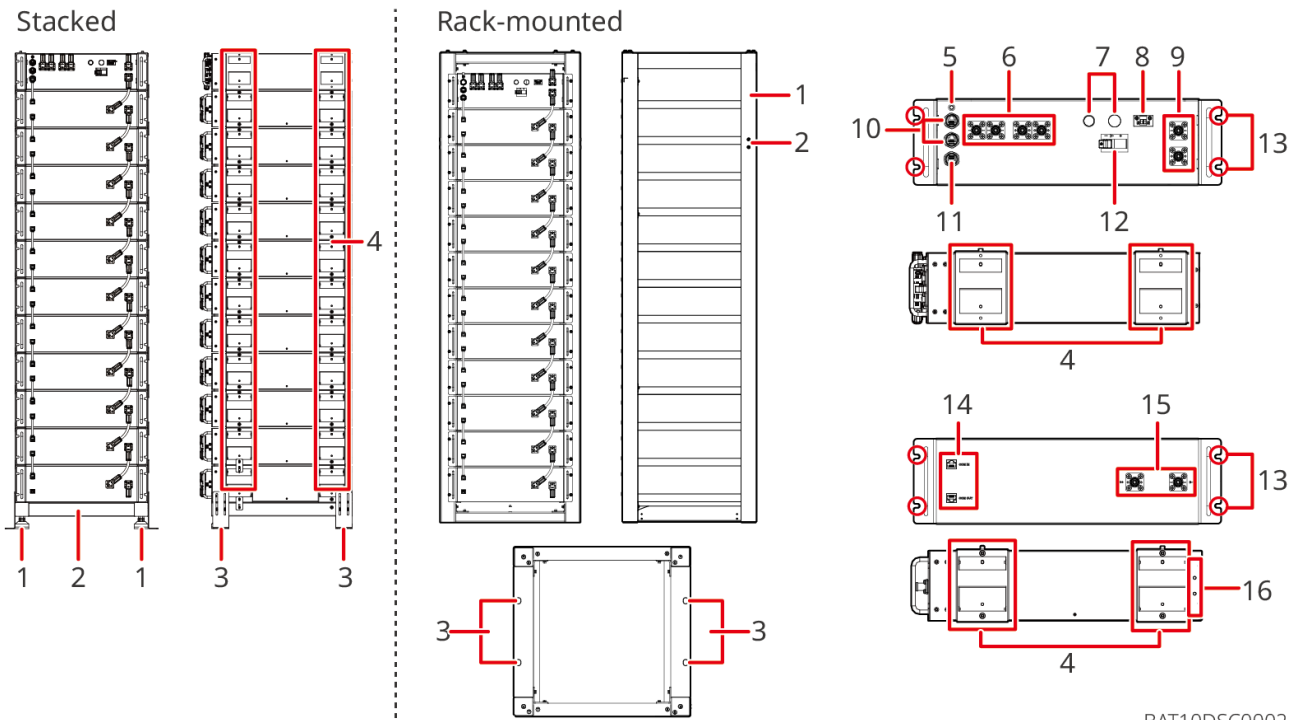

BAT10DSC0002

No.	Name	Description	
Stacking Installation	1	Adjustable Feet	Adjustable in height to keep the base level
	2	Base	The battery system is stacked and placed on the base
	3	Floor Locking Bracket	Used to secure the base to the floor to prevent tipping
	4	Stacking Bracket	Fixed on the battery PACK for stacking installation of batteries
Rack Installation	1	Battery Rack	Used for installing the battery system
	2	Wall Locking Bracket Mounting Hole	Used to secure the battery rack to the wall to prevent tipping
	3	Floor Locking Bracket Mounting Hole	Used to secure the battery rack to the floor to prevent tipping

No.	Name	Description
5	Protective Grounding Point	Used for connecting the ground wire
6	High Voltage Box Power Input/Output Port 1	Connects the power cable between the high voltage box and the inverter
7	Battery Indicators	Used to indicate the status of the battery system
8	Dry Contact	Contact for external fire protection system activation (Normally, the dry contact remains open. When a closed dry contact is detected, the battery system will automatically power down)
9	High Voltage Box Power Input/Output Port 2	Connects the power cable between the high voltage box and the battery module
10	External Communication Port	For communication with the inverter / placing terminal resistor / battery system cluster communication
11	High Voltage Box Communication Port	For communication with the battery module
12	Battery System Switch	Controls the start and stop of the battery system
13	High Voltage Box / Battery PACK Mounting Hole	Used to secure the high voltage box / battery PACK to the battery rack
14	Battery Module Communication Port	Used for communication between adjacent battery PACKs, and between battery PACK and high voltage box

No.	Name	Description
15	Battery Module Power Input/Output Port	Connects the power cable between adjacent battery PACKs
16	Wall Locking Bracket Mounting Hole	Used for installing the wall locking bracket. Only the first and last battery PACKs need to install the wall locking bracket.

### 2.2.2.3 BAT-C Series 61.4-112.6kWh Commercial & Industrial Battery System

No.	model	PACK Quantity	Rated Capacity (kWh)
1	GW61.4-BAT-AC-G10	6	61.4
2	GW92.1-BAT-AC-G10	9	92.1
3	GW102.4-BAT-AC-G10	10	102.4
4	GW112.6-BAT-AC-G10	11	112.6

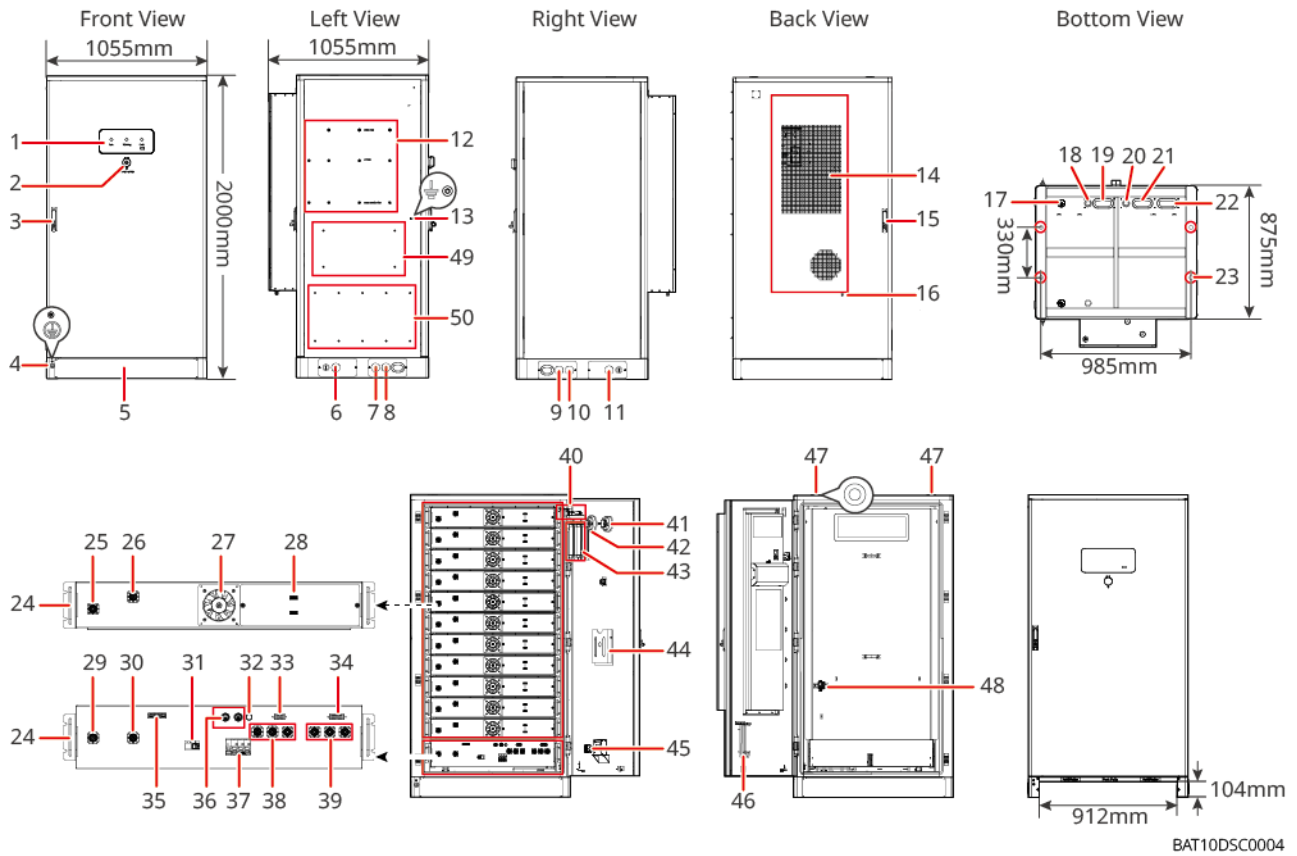

No.	Name	Description
1	LED indicator light	-
2	Emergency stop button	Pressing the emergency stop button will power down the battery system
3	Front door lock	-
4	PE port 1	Connect to battery grounding cable
5	Bottom baffle	-
6	Left side cable entry hole 1	Air conditioner power cable & ET100 power cable
7	Left side cable entry hole 2	Inverter communication cable
8	Left side cable entry hole 3	Inverter power cable

No.	Name	Description
9	Right side cable entry hole 1	Battery cluster parallel power cable
10	Right side cable entry hole 2	Battery cluster parallel communication cable
11	Right side cable entry hole 3	Air conditioner power cable
12	Back mounting plate installation hole	Inverter back mounting plate installation hole position
13	PE port 2	Connect to inverter grounding cable
14	Air conditioner	Responsible for temperature control, the air conditioner refrigerant model is R134A
15	Rear door lock	-
16	Air conditioner drain pipe installation port	-
17	Explosion-proof valve	Responsible for explosion-proof, exhaust, and other functions. When abnormal pressure increase occurs inside the battery system, by opening the explosion-proof one-way valve exhaust port, quickly and directionally release internal gas, thereby preventing the battery system from exploding.
18	Communication cable inlet/outlet (bottom)	Communication cable inlet/outlet between battery and inverter
19	Power cable inlet/outlet (bottom)	Power cable inlet/outlet between battery and inverter
20	Battery communication cable inlet/outlet	Battery cluster parallel communication cable inlet/outlet

No.	Name	Description
21	Battery power cable inlet/outlet (positive)	Battery cluster parallel power cable inlet/outlet (positive)
22	Battery power cable inlet/outlet (negative)	Battery cluster parallel power cable inlet/outlet (negative)
23	Foundation fixing hole	Hereby fasten the battery system and foundation together
24	Handle	-
25	Battery PACK power input/output port positive	-
26	Battery PACK power input/output port negative	-
27	Fan	-
28	Battery PACK communication port	Communication between adjacent battery PACKs, communication with high-voltage box, fan power supply
29	High-voltage box power input/output port negative 1	Connect power cable between high-voltage box and battery PACK
30	High-voltage box power input/output port positive 1	
31	Molded case circuit breaker	Control the high-voltage output of the battery system
32	Black start button	Control the black start of the battery system
33	Internal communication port 1	Communication with battery PACK and battery PACK fan power supply port 1

No.	Name	Description
34	Internal communication port 2	Air conditioner communication, access control identification, emergency stop and fire signal communication port
35	LAN communication port	LAN communication between batteries, used for transmitting cell-level information (Only machines shipped after October 2025 support this)
36	External communication port 1	Communication with inverter / place terminal resistor / battery system cluster parallel communication
37	Air switch	Control the low-voltage power supply of the battery system
38	High-voltage box power input/output port positive 2	Connect power cable between high-voltage box and inverter
39	High-voltage box power input/output port negative 2	Connect power cable between high-voltage box and inverter
40	Access control switch	Automatically disconnects after opening the door, ensuring the energy storage system is powered off

No.	Name	Description
41	Temperature detector	<p>The temperature detector monitors temperature through a dual thermistor network and outputs a voltage proportional to the external air temperature. One thermistor is exposed to ensure good thermal contact with the surrounding air, while the other thermistor is designed with thermal insulation, and when an abnormality is detected, it emits red light to alert the operator.</p> <ul style="list-style-type: none"> <li>• Suitable for environments with dust or smoke under normal conditions</li> <li>• Wide operating voltage range</li> </ul>
42	Smoke detector	<p>The smoke detector uses the principle of scattered light to detect smoke entering the detector housing cavity.</p> <ul style="list-style-type: none"> <li>• Good response to slow-burning, smoldering fires</li> <li>• Unaffected by wind or atmospheric pressure</li> <li>• Some models are equipped with flashing LED and magnetic test switch</li> <li>• Alarm indicator: Red light-emitting diode (LED) emits red light.</li> </ul>

No.	Name	Description
43	Aerosol fire extinguishing device	Monitor fire signals inside the cabinet, implement fire extinguishing. When a fire occurs, the aerosol fire extinguishing device ignites the thermal fuse after receiving an electrical start signal or open flame. The electric igniter thermal fuse burns and activates the aerosol generator in the fire extinguishing device. The aerosol generator decomposes the chemical coolant through the heat released by a series of reactions, enabling the aerosol generator and coolant to combine for fire extinguishing.
44	Document shelf	-
45	Fire action signal port	Dry contact signal interface, normally NC (normally closed state). Voltage: 0-24Vdc, Current: 0.3A. Connect to audible and visual alarm cable
46	Maintenance hook shelf	When disassembling Pack and PCU, the maintenance hook can be taken out from here for operation
47	Lifting ring installation hole	-
48	Air conditioner switch	Connect air conditioner power cable, control air conditioner power supply

### Fire Protection System Description

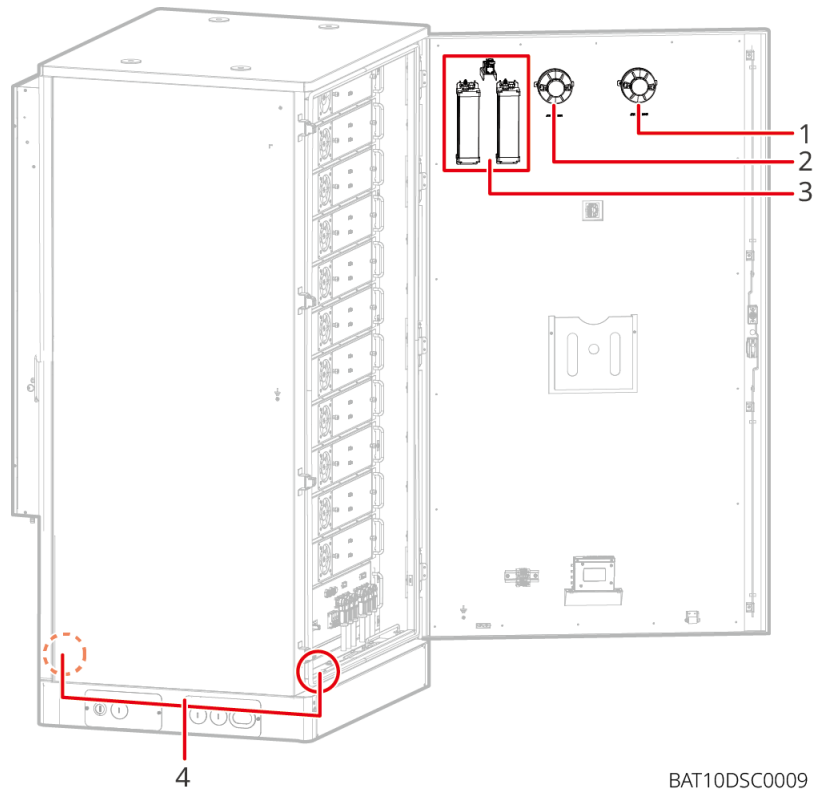

BAT10DSC0009

1	2	3	4
Smoke Detector	Heat Detector	Aerosol Fire Extinguishing Device	Explosion-proof Valve

■ **Temperature Detector & Smoke Detector**

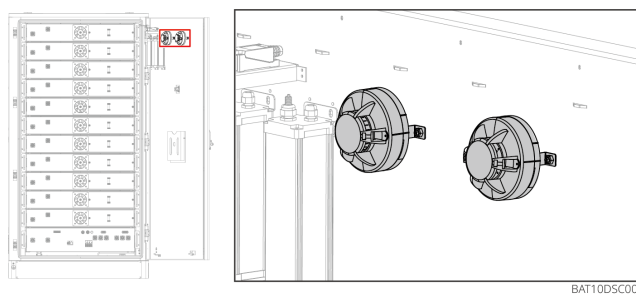

BAT10DSC0011

**Temperature Detection Principle:** The detector uses a negative temperature coefficient thermistor as a sensor, leveraging its sensitivity to ambient temperature to obtain environmental temperature information. The internal circuitry converts this information into a voltage signal and transmits it to the microcontroller. The microcontroller analyzes and processes the signal using built-in intelligent algorithms, simultaneously determining whether it is in a fire alarm or fault state.

**Smoke Detection Principle:** The detector uses infrared scattering to detect fires. In

a smoke-free state, it receives only very weak infrared light. When smoke particles enter the optical smoke detection chamber, scattering causes the received light signal to strengthen. When smoke concentration reaches a certain level, an alarm signal is output.

Technical Specifications	Heat Detector	Smoke Detector
Dimensions (mm)	102 × 55	
Installation Requirements	Screw fixation	
indicator (Red)	Flashes during monitoring, stays on during alarm	
Operating Temperature (°C)	-40~+85	
Relative Humidity	≤95%RH (non-condensing)	

▪ **Explosion Relief Vent**

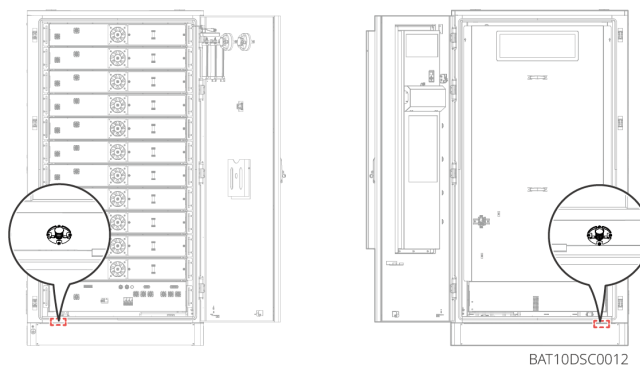

When the internal pressure of sealed products like the battery cabinet rapidly increases, the explosion relief vent (a one-way valve) opens its exhaust port to quickly and directionally release internal gas, thereby preventing explosions in sealed products such as battery cabinets.

Technical Specifications	Explosion Relief Valve
Ingress Protection Rating	IP68
Opening Area	570 mm <sup>2</sup>
Operating Temperature	-40°C ~ +130°C
Flame Retardancy	UL94-V0

▪ **Aerosol Fire Suppression Device**

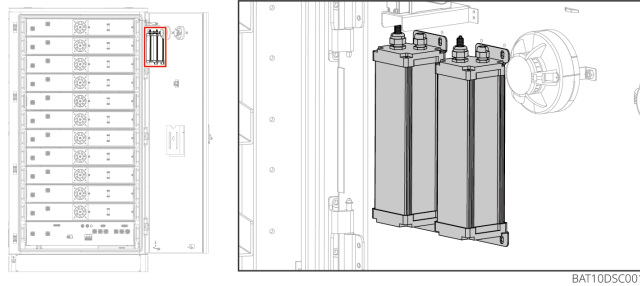

When a fire occurs, upon receiving an electrical activation signal or when an open flame ignites the thermal fuse, the electric initiator or burning thermal fuse activates the aerosol-forming agent inside the fire suppression device. The heat released by the redox reaction of the aerosol-forming agent causes the chemical coolant to decompose, enabling both the aerosol-forming agent and the coolant to participate in fire suppression.

Technical Specifications	Aerosol Fire Extinguishing Device
Operating Environment Temperature Range	-30°C ~ +70°C
Operating Environment Relative Humidity	≤95%RH

Technical Specifications	Aerosol Fire Extinguishing Device
Thermal Activation Temperature	185±10°C

### Fire Protection Logic

The fire protection for this battery system employs a tiered response design. When a fire occurs inside a battery Pack, it is first detected by the Pack-level detector, which immediately activates the Pack's internal aerosol fire suppression device for initial firefighting. If the fire is not controlled and spreads further, it triggers cabinet-level fire protection. When both the smoke detector and temperature detector detect a fire, or when an open flame ignites the thermal fuse (temperature reaches 180°C), the cabinet-level aerosol fire suppression device is automatically activated for comprehensive firefighting. The aerosol-forming agent produces fire suppressant through a combustion reaction, and the heat released during the reaction decomposes the chemical coolant. The aerosol fire suppressant and coolant work synergistically to extinguish the fire. Simultaneously, the BMS receives the feedback signal from the fire protection system, triggering external audible and visual alarms until the fire is completely extinguished.

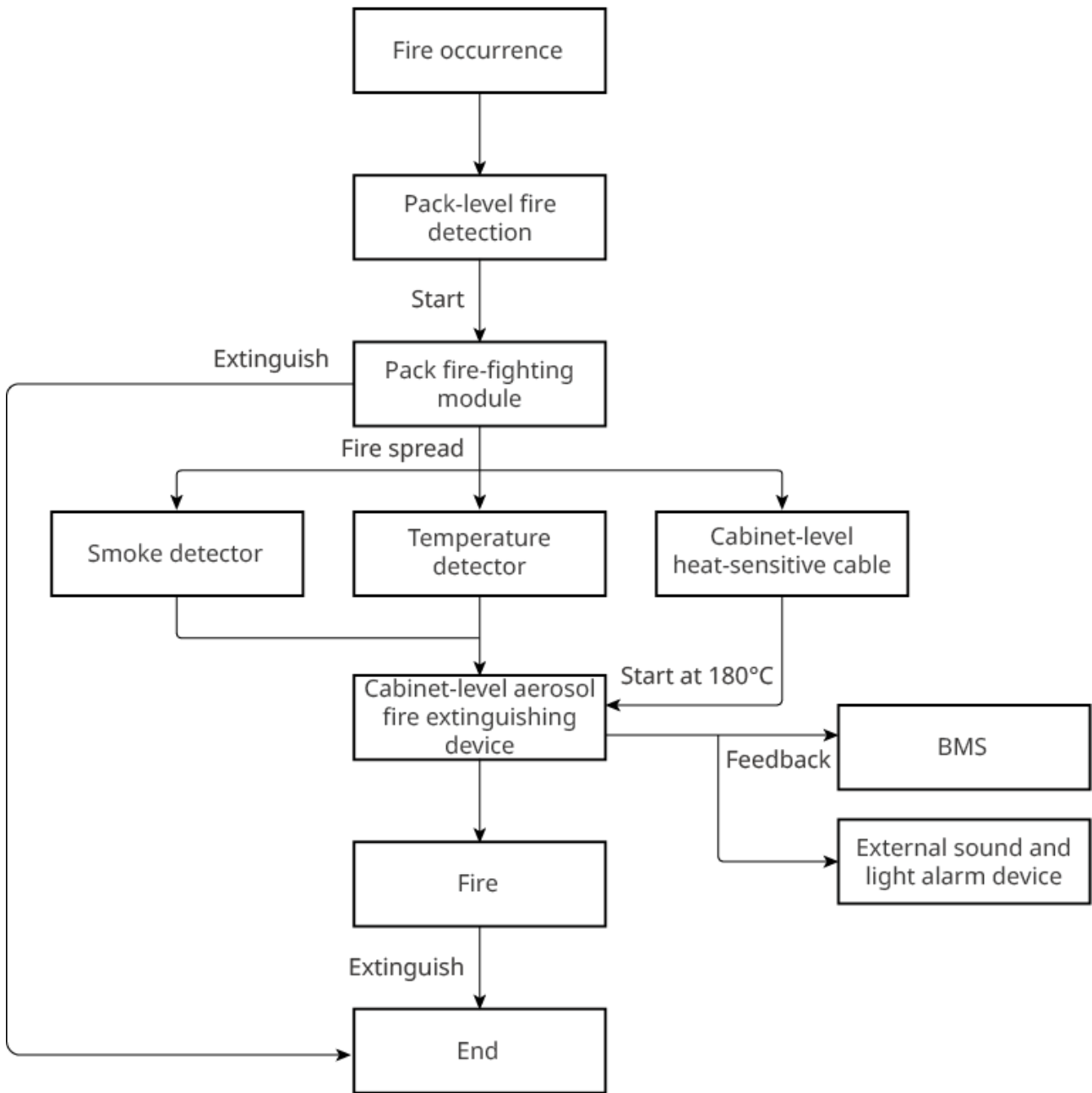

ET5010MTN0001

### 2.2.3 Smart Meter

The Smart Meter can measure parameters such as grid voltage, current, power, frequency, and electrical energy, and transmit the information to the inverter to control the input and output power of the energy storage system.

GM3000&CT

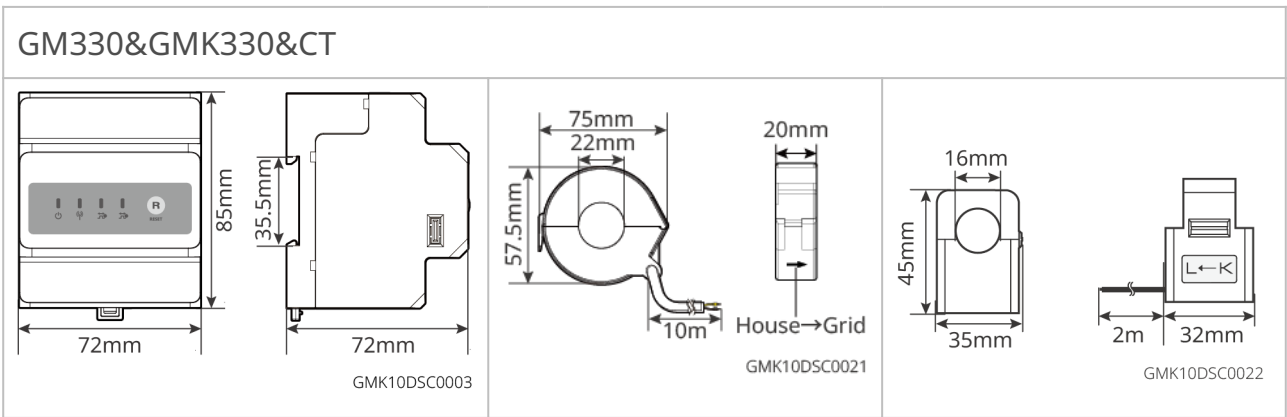
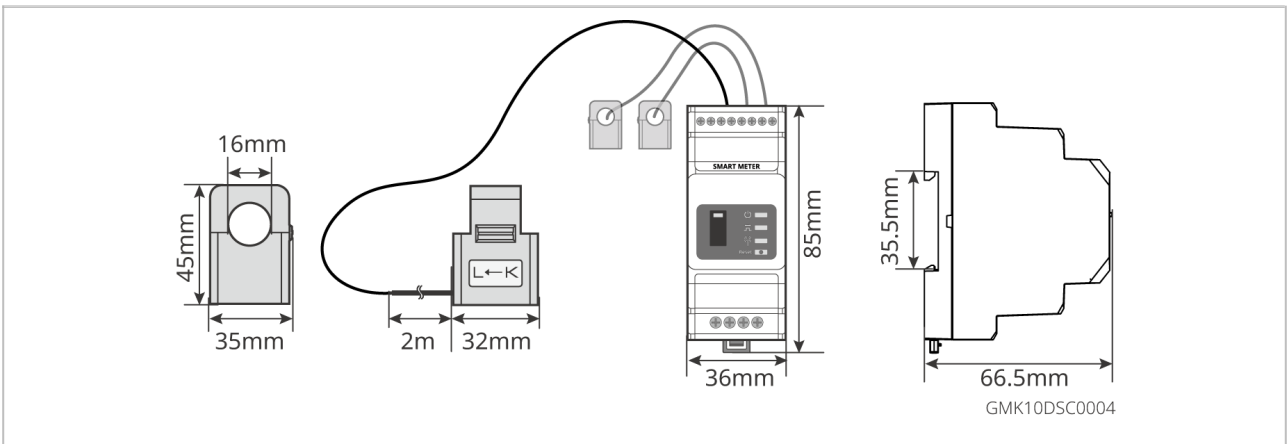

No.	model	Applicable Scenarios
1	GM3000	CT replacement not supported, CT ratio: 120A: 40mA
2	GM330	CT can be purchased from GoodWe or separately, CT ratio requirement: nA: 5A <ul style="list-style-type: none"> <li>nA: CT primary side input current, where n ranges from 200-5000</li> <li>5A: CT secondary side output current</li> </ul>
3	GMK330	CT shipped with the meter, CT ratio: <ul style="list-style-type: none"> <li>120A: 40mA</li> <li>200A: 50mA (Brazil only)</li> </ul>

### 2.2.4 smart dongle

The smart dongle is primarily used for real-time transmission of various inverter

power generation data to the SEMS Portal remote monitoring platform, and for connecting the smart dongle via the SolarGo APP for local device debugging.

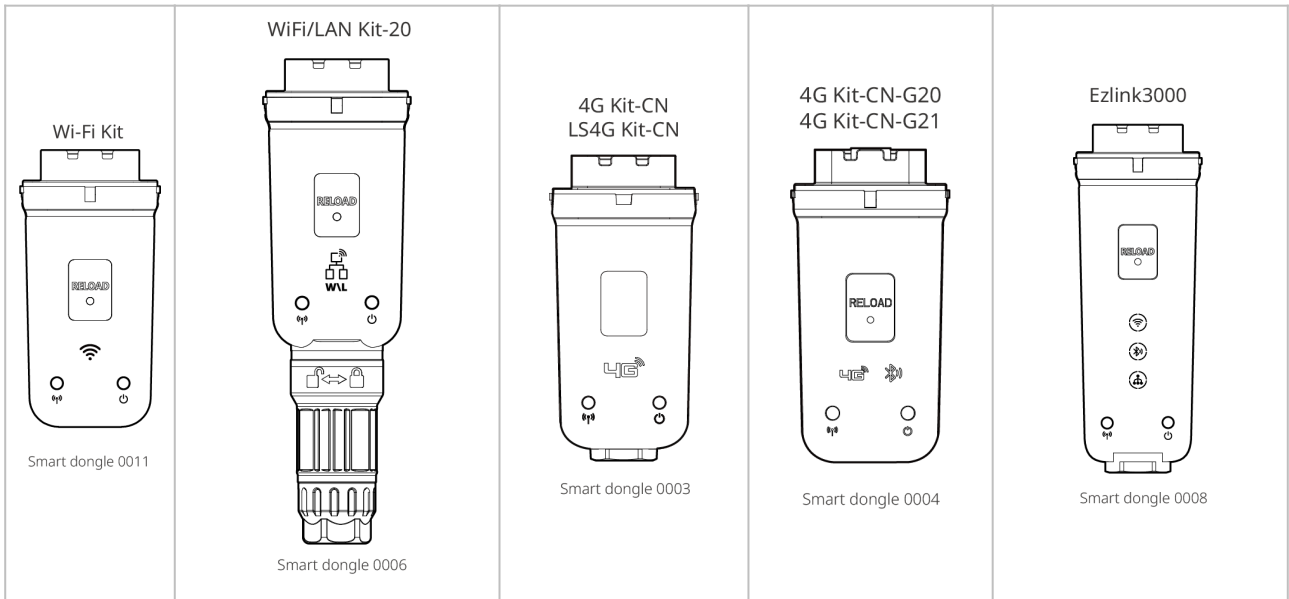

No.	model	Signal Type	Applicable Scenario
1	Wi-Fi Kit	WiFi	Inverter Standalone Scenario
2	WiFi/LAN Kit-20	WiFi, LAN, Bluetooth	
3	LS4G Kit-CN 4G Kit-CN	4G	
4	4G Kit-CN-G20 4G Kit-CN-G21	4G, Bluetooth 4G, Bluetooth, CNSS	
5	Ezlink3000	WiFi, LAN, Bluetooth	Master Unit in Multi-Inverter Scenario

## 2.3 Supported Grid Types

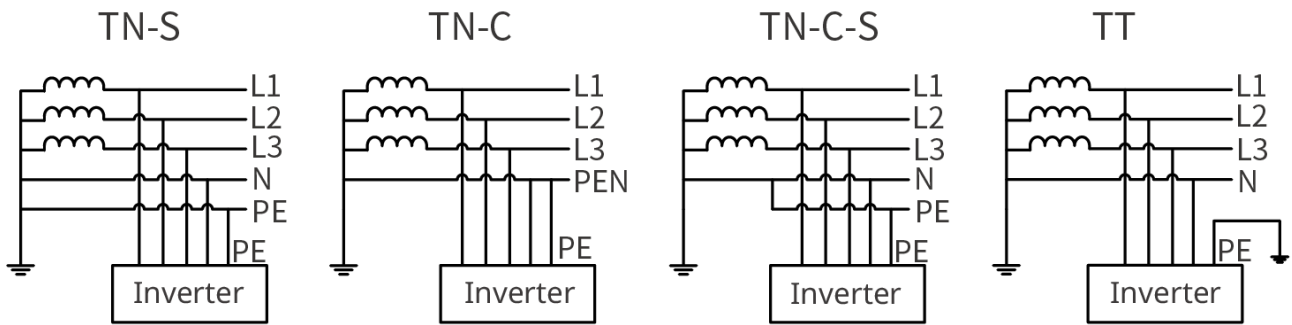

TNNET0003

## 2.4 System Working Mode

### NOTICE

After the initial installation of the GW14.3-BAT-LV-G10 and GW16.1-BAT-LV-G10 battery systems, an automatic full battery charge will be performed. Upon completion, the system will switch to operate in the set working mode.

### Self-use Mode

- The basic operating mode of the system.
- PV generation supplies power to loads with priority; excess electricity charges the battery, and any remaining electricity is sold to the grid. When PV generation does not meet the load demand, the battery supplies power to the loads; when the battery power is also insufficient, the grid supplies power to the loads.

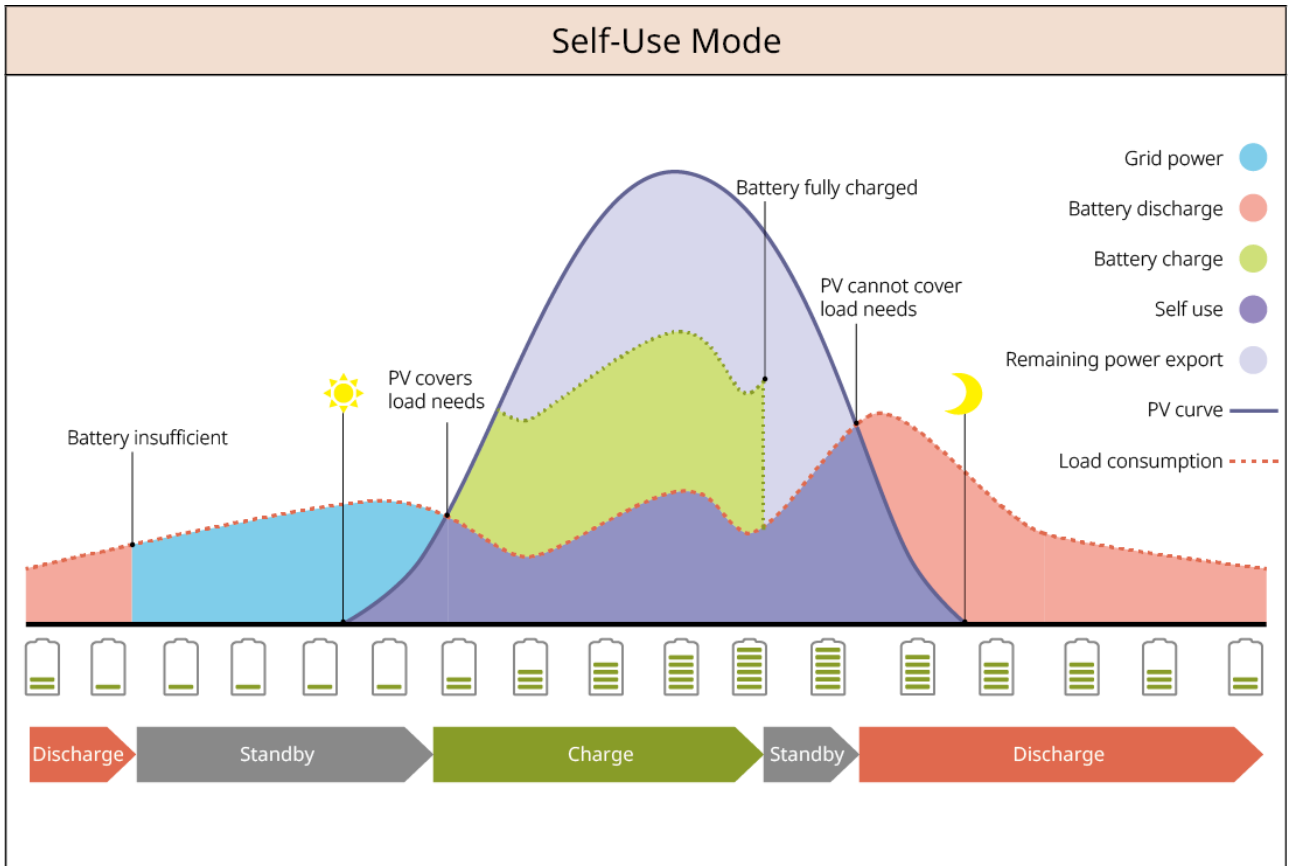

SLG00NET0009

## Backup Mode

- Recommended for use in areas with unstable grid.
- When the grid fails, the inverter switches to off-grid operation mode, and the battery discharges to supply power to the loads, ensuring that the BACK-UP Loads do not lose power; when the grid is restored, the inverter switches back to grid-connected operation.
- To ensure that the battery SOC is sufficient to maintain normal system operation when off-grid, during grid-connected operation, the battery will use PV or purchase electricity from the grid to charge to the backup power SOC. If purchasing electricity from the grid to charge the battery, please confirm that it complies with local grid laws and regulations.

# Back-up Mode ①

Charging from grid: disabled

Back-up SOC: 60%

Grid connected      Grid disconnected      Grid connected

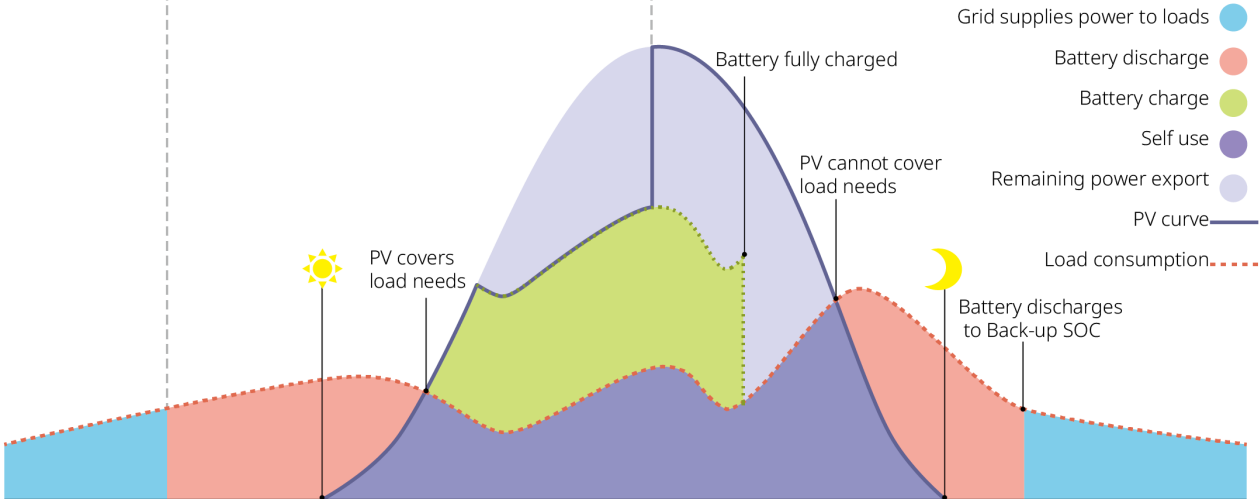

SLG00NET0002

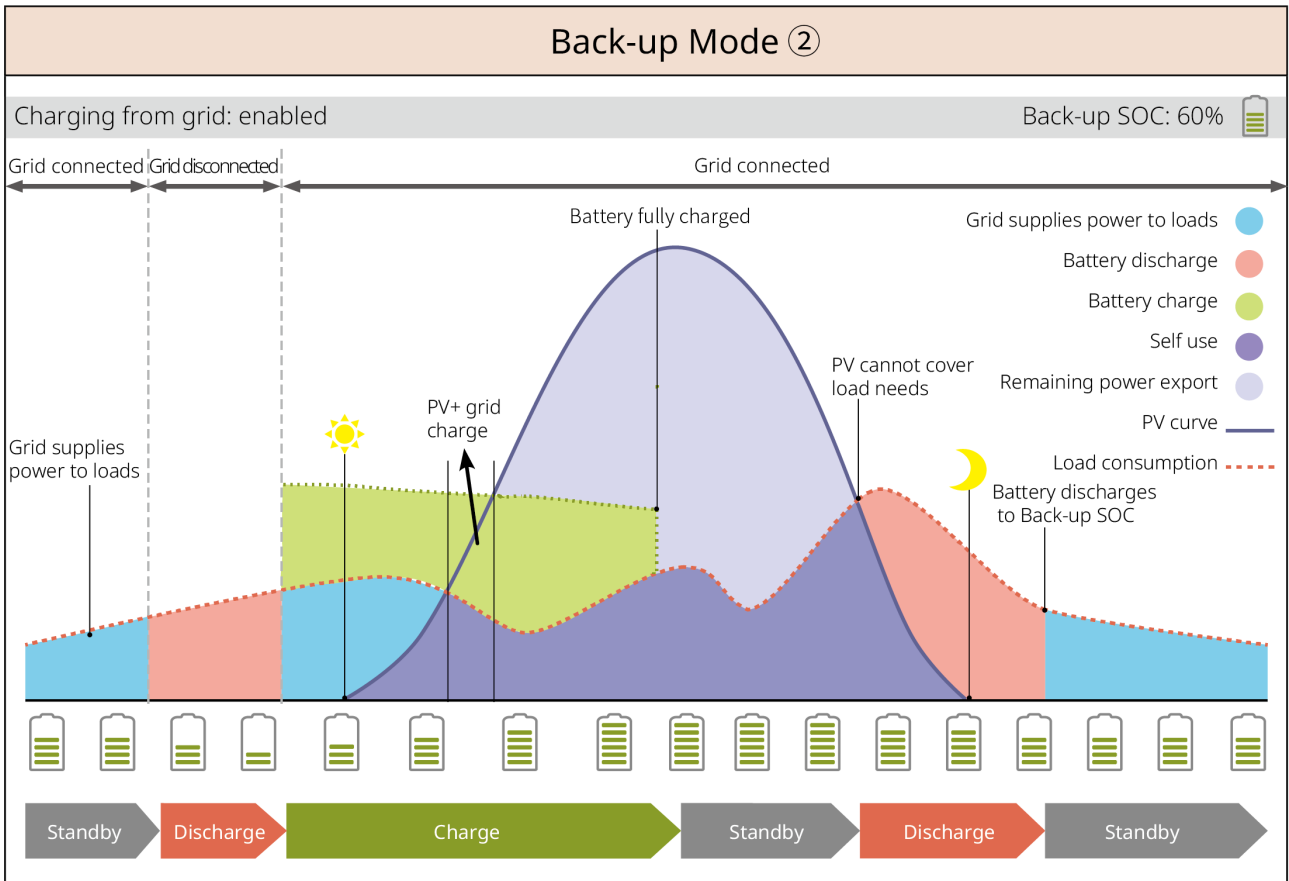

SLG00NET0003

## TOU Mode

Under the premise of complying with local laws and regulations, based on the difference between peak and valley electricity prices of the grid, set different time periods for buying and selling electricity.

For example: during valley price periods, set the battery to charging mode, purchasing electricity from the grid to charge; during peak price periods, set the battery to discharging mode, supplying power to loads through the battery.

# TOU Mode ①

PV: Charge battery in priority

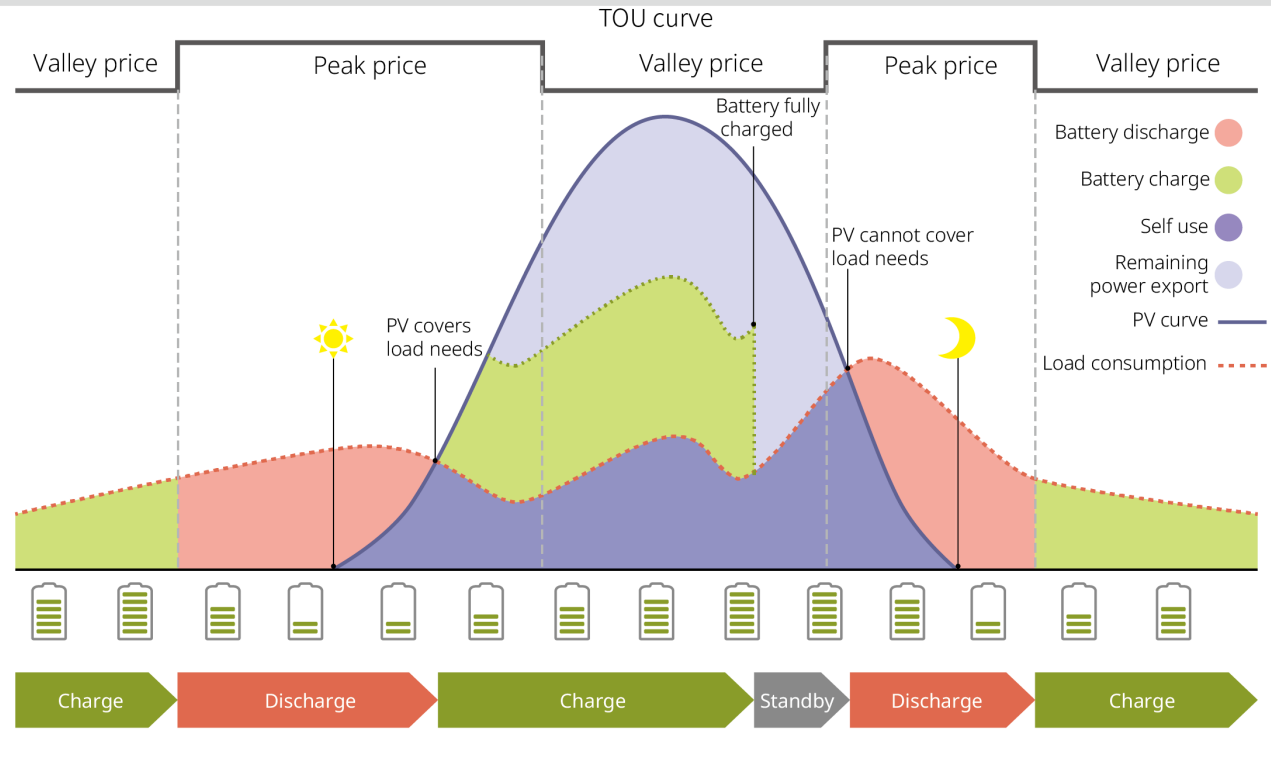

SLG00NET0004

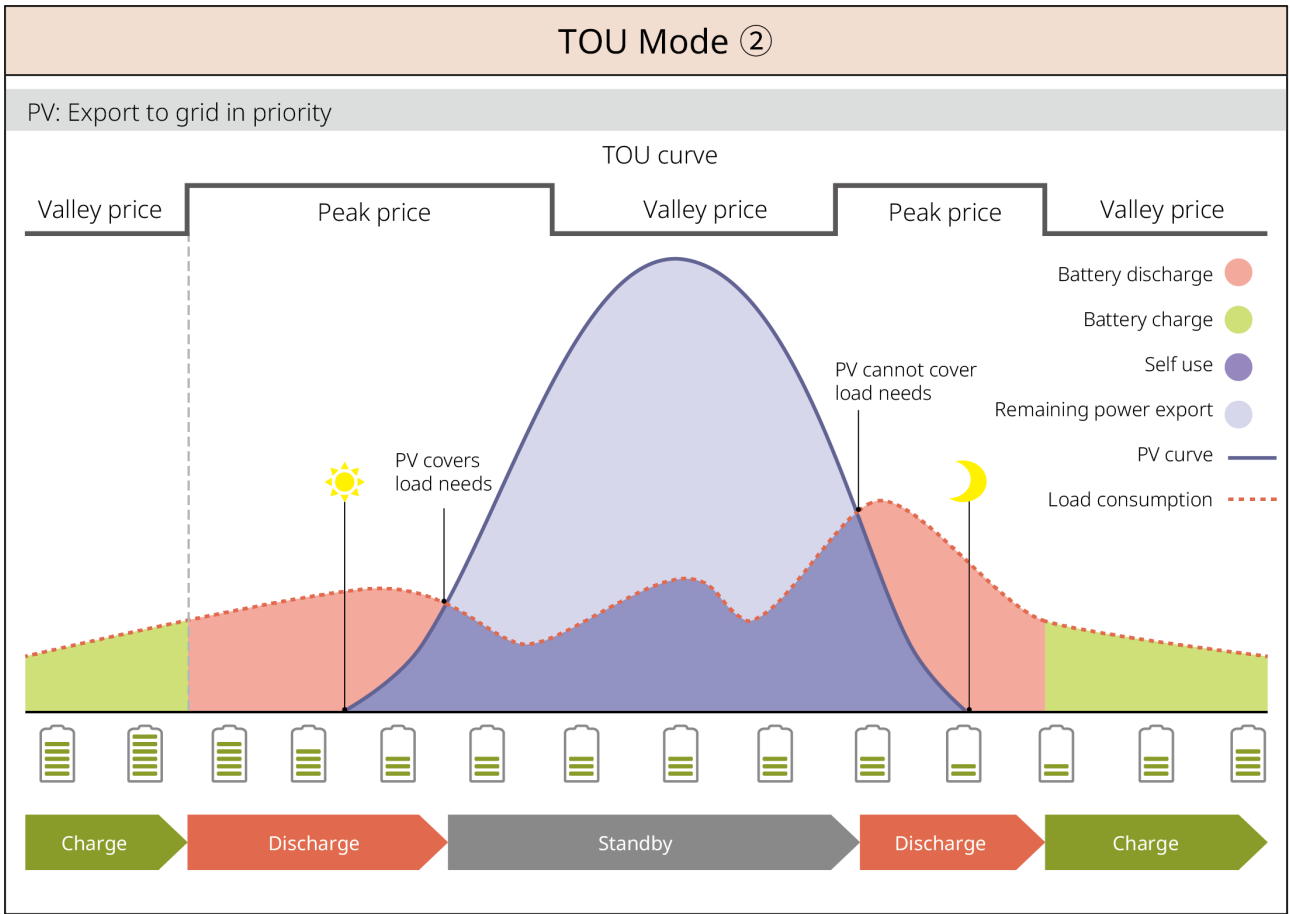

SLG00NET0005

### Delayed Charging Mode

- Suitable for areas with grid-connected power output limits.
- Setting a peak power limit can use PV generation that exceeds the grid-connected limit to charge the battery; or set PV charging periods to use PV generation to charge the battery during those periods.

# Delayed Charging ①

PV > Peak Limit

Switch to Charge: enabled/disabled

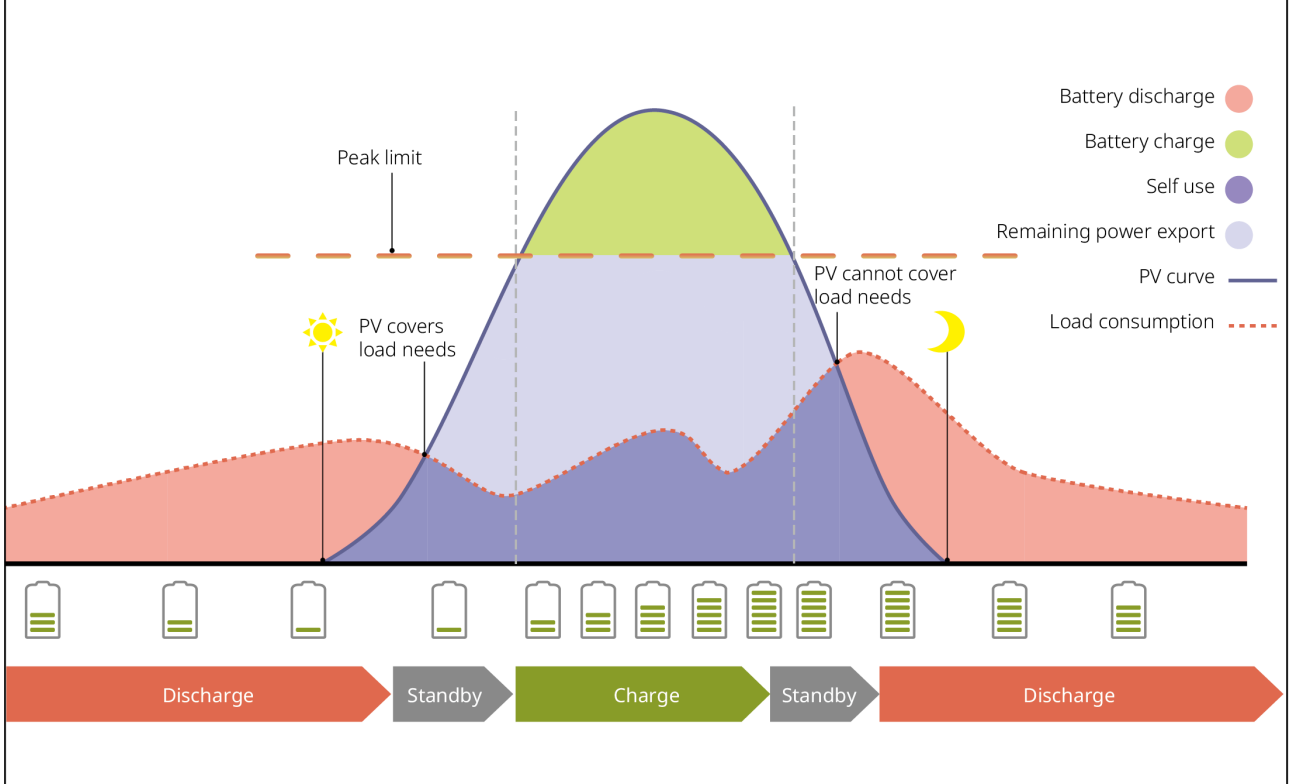

SLG00NET0006

## Delayed Charging ②

PV < Peak Limit

Switch to Charge: enabled

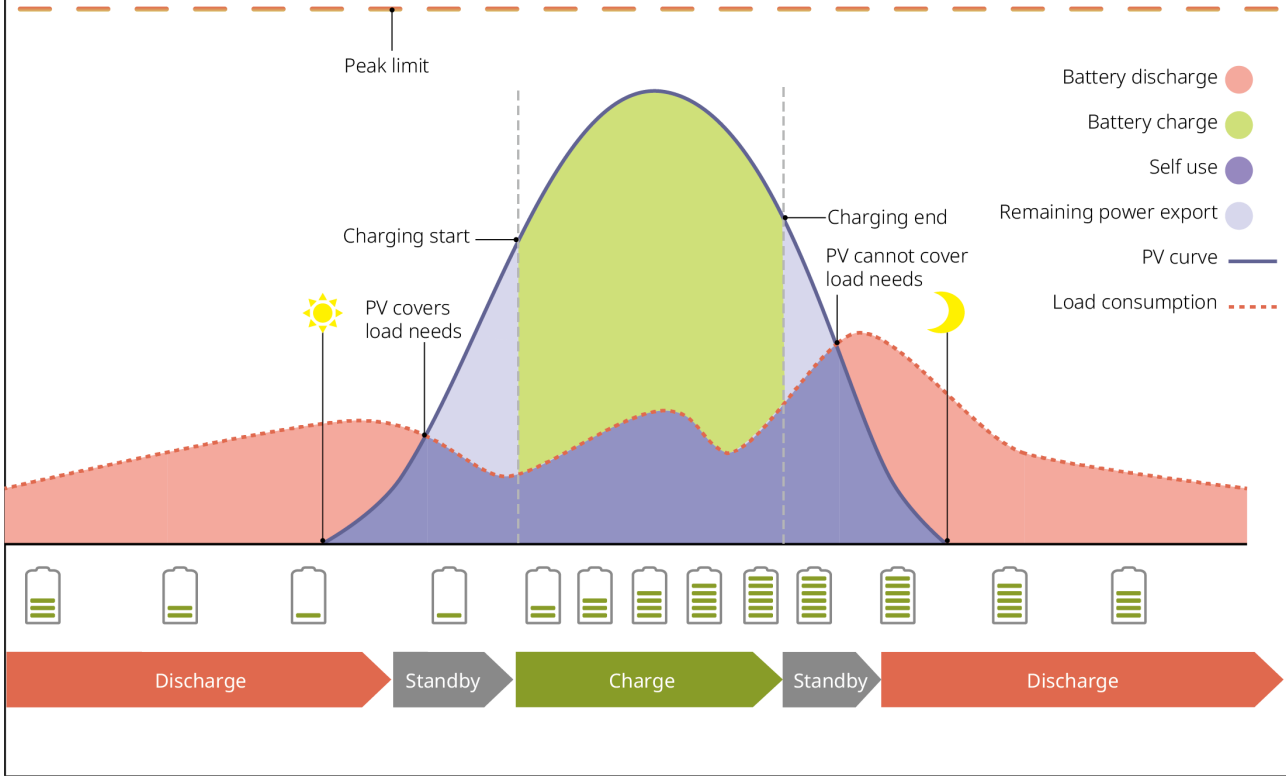

SLG00NET0007

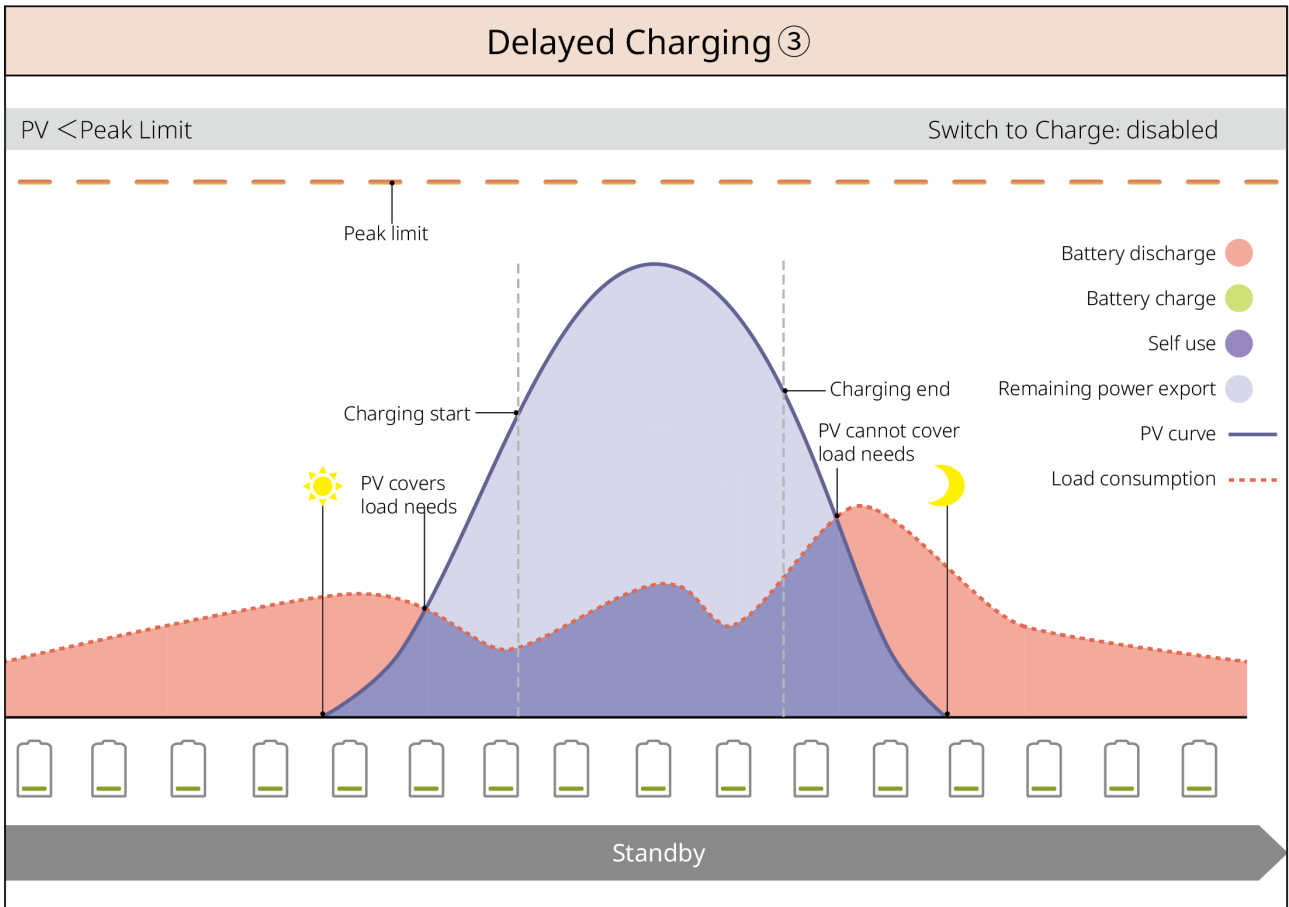

SLG00NET0008

### Demand Control Mode

- Mainly applicable to industrial and commercial scenarios.
- When the total power consumption of loads exceeds the electricity quota in a short time, battery discharge can be used to reduce the portion of electricity consumption that exceeds the quota.
- When the SOC of both battery circuits of the inverter is below the reserved SOC for demand control, the system purchases electricity from the grid based on time periods, load electricity consumption, and the peak purchase power limit; when only one battery circuit of the inverter has SOC below the reserved SOC for demand control, the system purchases electricity from the grid based on load electricity consumption and the peak purchase power limit.

# Peakshaving ①

BAT1/BAT2 SOC < 80

Reserved SOC For Peakshaving: 80 

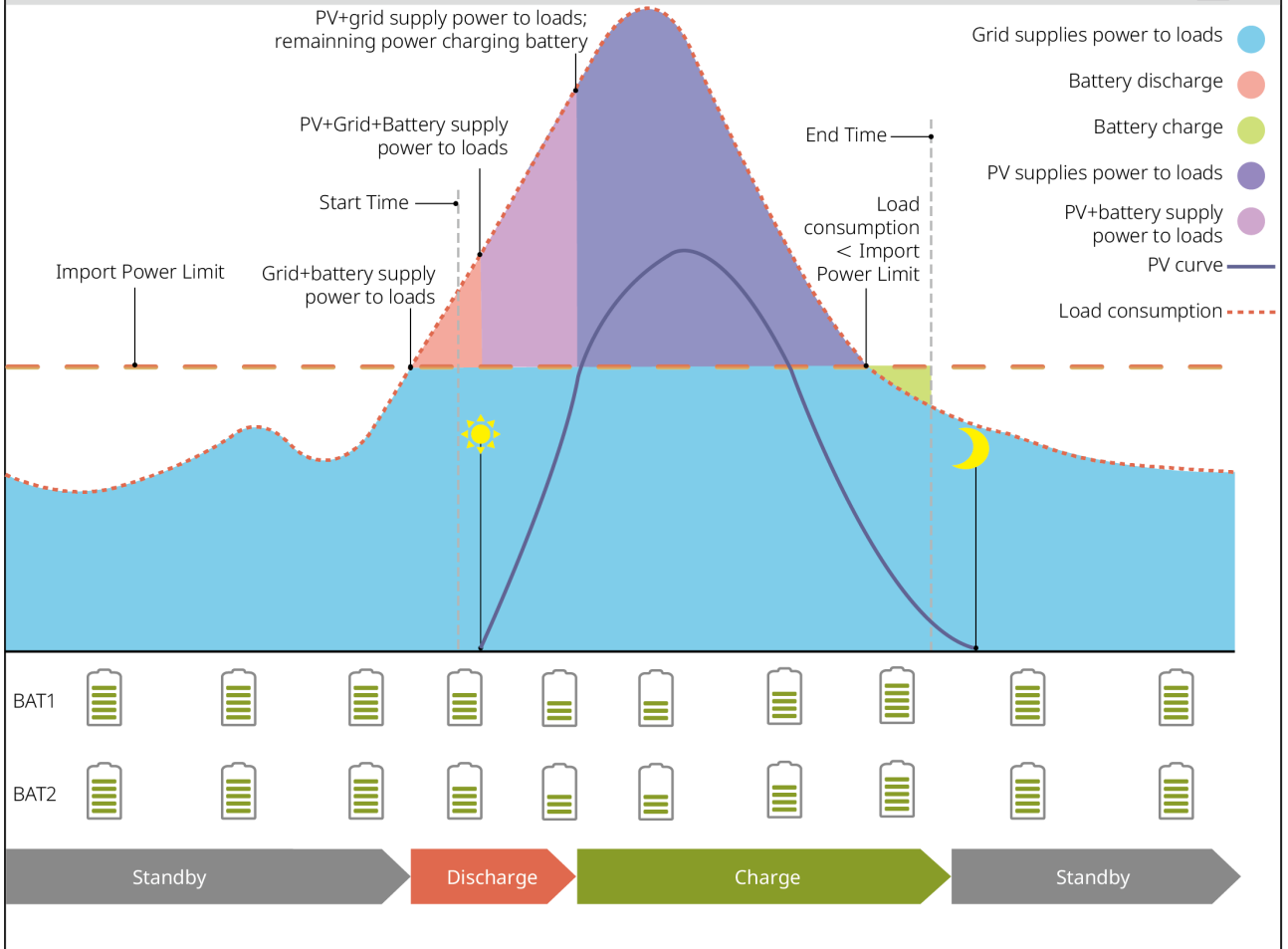

SLG00NET0010

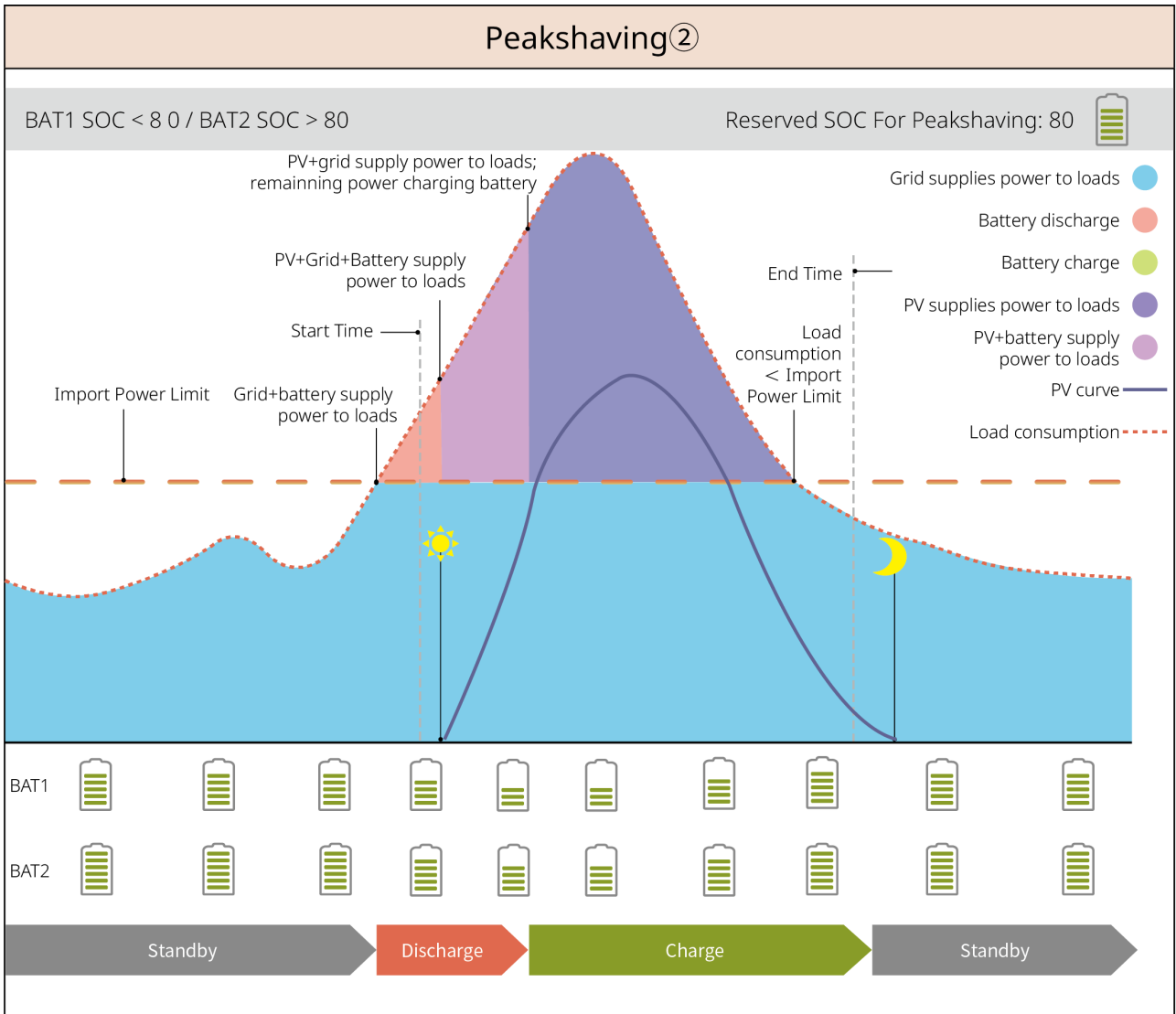

SLG00NET0011

## Off-grid Mode

### NOTICE

Do not operate in pure off-grid mode when the inverter is not connected to the battery system.

When the grid fails, the inverter switches to off-grid operation mode.

- During the day, PV generation supplies power to loads with priority, and excess electricity charges the battery.
- At night, the battery discharges to supply power to loads, ensuring that the BACK-UP Loads do not lose power.
- Off-grid SOC recovery: After the system operates off-grid, the battery gradually

recovers to the minimum SOC through PV generation or other generation methods.

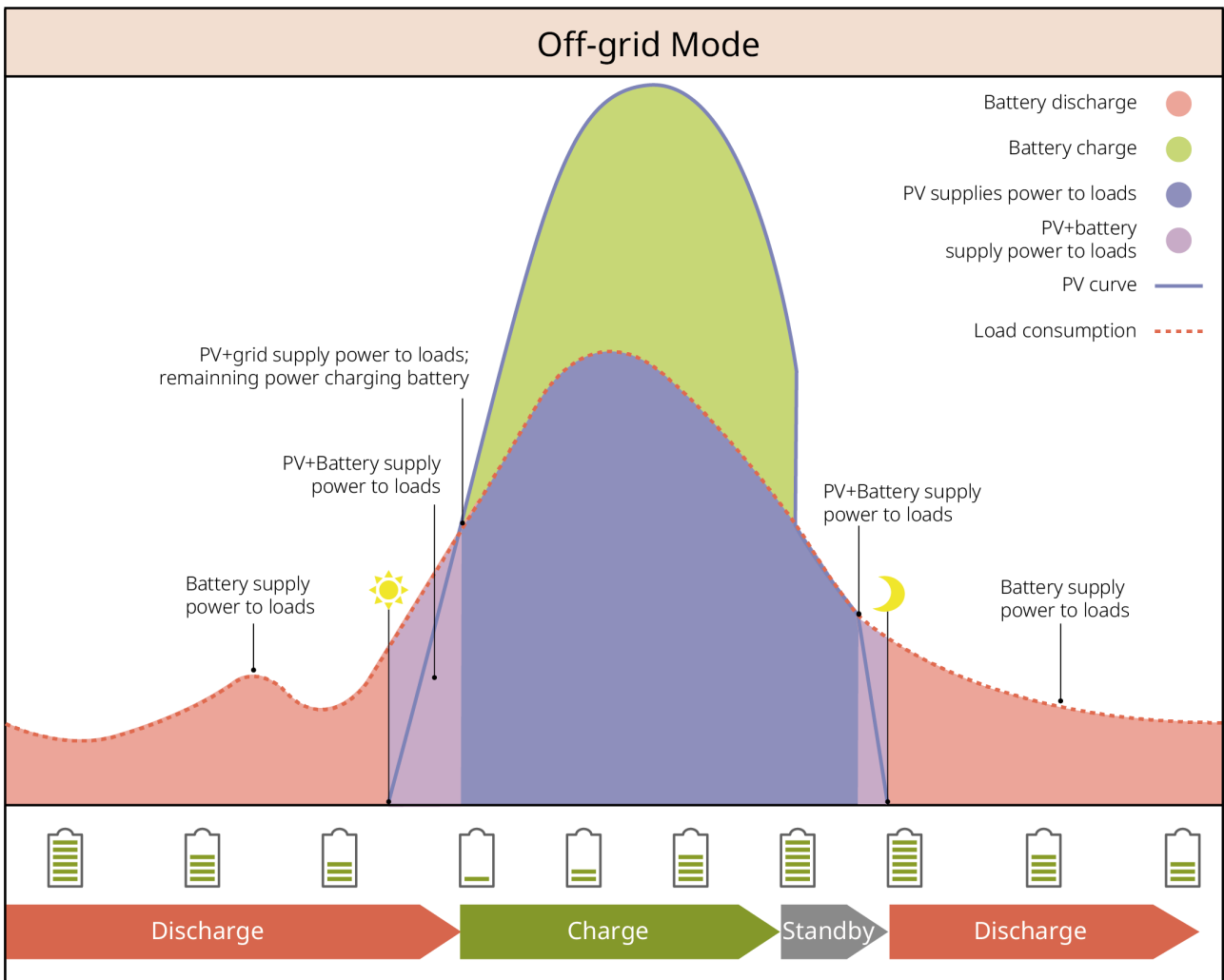

SLG00NET0012

## 2.5 Features

### NOTICE

Specific features are subject to the actual product configuration.

#### AFCI

The inverter integrates an AFCI circuit protection device, which is used to detect arc faults and quickly cut off the circuit when detected, thereby preventing electrical fires.

Causes of arc generation:

- Damage to connector connections in the photovoltaic system.
- Incorrect or damaged cable connections.
- Aging of connectors or cables.

Fault handling methods:

1. When the inverter detects an arc, the fault type can be viewed via the inverter display or App.
2. If the inverter triggers a fault <5 times within 24 hours, it will automatically resume grid connection after a 5-minute wait. After the 5th arc fault, the fault must be cleared before the inverter can operate normally. For specific operations, please refer to the "SolarGo APP User Manual".

### Three-Phase Unbalanced Output

The inverter supports three-phase unbalanced output on both the grid-tied side and the BACK-UP side, allowing different power loads to be connected to each phase. The maximum output power per phase for different models is shown in the table below:

No.	model	Maximum Output Power per Phase
1	GW15K-ET	5kW
2	GW20K-ET	6.7kW
3	GW25K-ET	8.3kW
4	GW29.9K-ET	10kW
5	GW30K-ET	10kW

### load control

The inverter's dry contact control port supports connection to an additional contactor for controlling the switching on or off of loads. It supports household loads, heat pumps, etc.

Load control methods are as follows:

- Time Control: Set the time for turning the controlled load on or off. The load will automatically turn on or off within the set time period.
- Switch Control: When the control mode is set to ON, the load will turn on; when set to OFF, the load will turn off.
- BACK-UP Loads Control: The inverter has a built-in relay dry contact control port, which can control whether the load is turned off via the relay. In off-grid mode, if an overload on the BACK-UP side is detected and the battery SOC value is below

the set off-grid protection value, the load connected to the relay port can be turned off.

### **Rapid Shutdown (RSD)**

In a rapid shutdown system, the rapid shutdown transmitter and receiver work together to achieve rapid system shutdown. The receiver maintains module output by receiving signals from the transmitter. The transmitter can be external or built into the inverter. In an emergency, by enabling an external trigger device, the transmitter can be stopped, thereby shutting down the modules.

- External Transmitter
  - Transmitter Models: GTP-F2L-20, GTP-F2M-20  
<https://en.goodwe.com/Ftp/Installation-instructions/RSD2.0-transmitter.pdf>
  - Receiver Models: GR-B1F-20, GR-B2F-20  
[https://en.goodwe.com/Ftp/EN/Downloads/User%20Manual/GW\\_RSD-20\\_Quick-Installation-Guide-POLY.pdf](https://en.goodwe.com/Ftp/EN/Downloads/User%20Manual/GW_RSD-20_Quick-Installation-Guide-POLY.pdf)
- Built-in Transmitter
  - External Trigger Device: External switch
  - Receiver Models: GR-B1F-20, GR-B2F-20  
[https://en.goodwe.com/Ftp/EN/Downloads/User%20Manual/GW\\_RSD-20\\_Quick-Installation-Guide-POLY.pdf](https://en.goodwe.com/Ftp/EN/Downloads/User%20Manual/GW_RSD-20_Quick-Installation-Guide-POLY.pdf)

# 3 Check and Storage

## 3.1 Check Before Receiving



Before signing for the product, please carefully check the following:







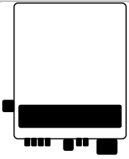
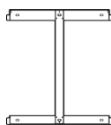
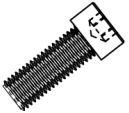
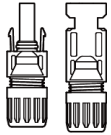

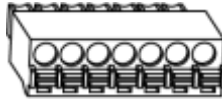
1. Check the outer packaging for any damage, such as deformation, holes, cracks, or any other signs that could indicate damage to the equipment inside the box. If damage is found, do not open the packaging and contact your dealer.
2. Check if the device model is correct. If it does not match, do not open the packaging and contact your dealer.

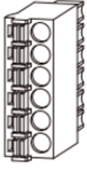
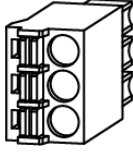

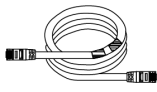
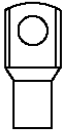

## 3.2 deliverables

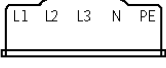
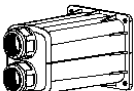

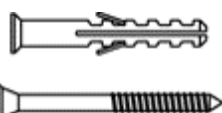
 <b>WARNING</b>	
<p>Check if the type and quantity of the delivered items are correct, and if there is any damage to the appearance. If damaged, please contact your dealer.</p> <p>After removing the delivered items from the packaging, do not place them on rough, uneven, or sharp surfaces to avoid paint chipping.</p>	

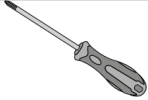
### 3.2.1 Inverter Deliverables

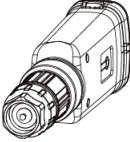

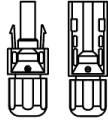

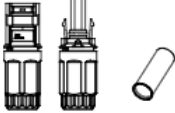

Part	Description	Part	Description
	Inverter x 1		Backplate x 1
	Back Mounting Screws x 2		PV Connector GW15K-ET, GW20K-ET: 4 GW25K-ET, GW29.9K-ET, GW30K-ET: 6
	PV Wiring Tool x 1		7PIN communication terminal x 1

Part	Description	Part	Description
	6PIN communication terminal x 1		3PIN communication terminal x 1
	Protective PE screw x 1		PIN terminal x N The PIN terminals included vary depending on the inverter configuration. Please refer to the actual contents.
	Grounding terminal x 1		BMS/Meter Communication cable GW15K-ET, GW20K-ET: 2 GW25K-ET, GW29.9K-ET, GW30K-ET: 3
<div style="border: 1px dashed black; padding: 5px; margin-bottom: 5px;">        </div> <p>or</p> <div style="border: 1px dashed black; padding: 5px;">  </div>	<p>Please refer to the actual shipment</p> <ul style="list-style-type: none"> <li>• OT terminal x 12</li> <li>• AC terminal flange nut x 20</li> <li>• Insulation board for AC terminal x 1</li> <li>• AC terminal protective cover x 1</li> <li>• Hexagon screwdriver x 1</li> </ul>		expansion bolt x 6

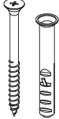
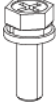
Part	Description	Part	Description
			<p>Smart meter and accessories x 1 Please refer to the actual shipment</p>
	screwdriver x 1		smart dongle x 1
	Product documentation x 1	<p>or</p> 	
 Wiring Tool  Battery connector	(Optional) Wiring Tool x 1 Battery connector: GW15K-ET, GW20K-ET: 1 GW25K-ET, GW29.9K-ET, GW30K-ET: 2		





Part	Description	Part	Description
 Wiring Tool  Hexagon screwdriver  Battery connector	(Optional) Wiring Tool x 2 Hexagon screwdriver x 1 Battery connector: GW12KL-ET, GW15K-ET, GW20K-ET: 1 GW18KL-ET, GW25K-ET, GW29.9K-ET, GW30K-ET: 2		





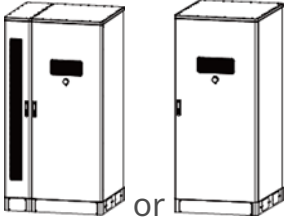



### Protective Cover Attachment (Australia only)





Part	Description	Part	Description
	cable tie x 10		expansion bolt x 4
	M5 Hex Screw x 10		M5 Nut x 5
	Protective Cover Right Side Panel x 1		Protective Cover Left Side Panel x 1
	Protective Cover Bottom Plate x 1		Protective Cover Front Cover Plate x 1

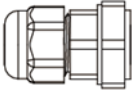

## 3.2.2 Batteries Deliverables

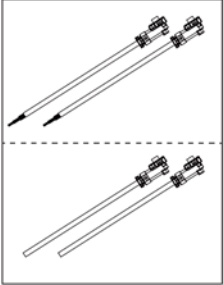
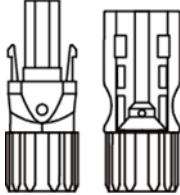
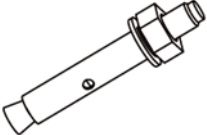
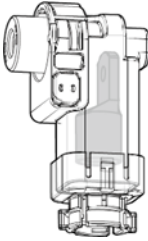
### 3.2.2.1 Lynx C Series 60kWh Commercial & Industrial Battery System

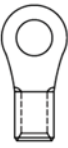
Component	Quantity	Component	Quantity
	<p>Battery system x 1            GW60KWH-D-10:            Includes AC cabinet            GW60KWH-D-10 (No            extension cabinet):            Does not include AC            cabinet</p>		<ul style="list-style-type: none"> <li>• Battery-Battery Connection Aluminum Busbar                When all busbars are shipped with accessories, the quantity in accessories is 10.</li> <li>• When some busbars are shipped with accessories, the quantity in accessories is 3 (other busbars are pre-installed on the battery).</li> </ul>
	<p>Battery-High Voltage Box Connection Aluminum Busbar</p> <ul style="list-style-type: none"> <li>• When the busbar is shipped with accessories, the quantity in accessories is 1.</li> <li>• When the busbar is pre-installed on the battery for shipment, the quantity in accessories is 0.</li> </ul>		<p>Battery-High Voltage Box Mounting Screws x 2</p>

Component	Quantity	Component	Quantity
	<p>Battery-Battery Mounting Screws</p> <ul style="list-style-type: none"> <li>• When all busbars are shipped with accessories, the quantity of screws in accessories is 22.</li> <li>• When some busbars are shipped with accessories, the quantity of screws in accessories is 6.</li> </ul>		<p>Lifting Rings x 4</p>
	<p>Inverter Back-up Wiring Terminals x 5</p>		<p>M12 Waterproof Components x 2</p>
	<p>M18 Waterproof Components x 2</p>		<p>M20 Waterproof Components x 2</p>
	<p>M22 Waterproof Components x 4</p>		<p> cable tie x 10</p>

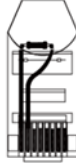
Component	Quantity	Component	Quantity
	<p>Inverter-High Voltage Box Power Cables GW60KWH-D-10 (No extension cabinet): 0 GW60KWH-D-10: 1</p>		<p>Inverter Battery Wiring Terminals GW60KWH-D-10 (No extension cabinet): 0 GW60KWH-D-10: N N: Please refer to the actual product shipment.</p>
	<p>Expansion screw x 4</p>		<p>High Voltage Box Power Wiring Terminals GW60KWH-D-10 (No extension cabinet): 2 GW60KWH-D-10: 1</p>
	<p>Air Conditioner Water Pipe x 1</p>		<p>M5 Nuts x 9</p>
	<p>Grounding terminal x 1</p>		<p>Inverter-High Voltage Box Communication Cable GW60KWH-D-10: 1 GW60KWH-D-10 (No extension cabinet): 0</p>

Component	Quantity	Component	Quantity
	Product Documentation x 1		Terminating Resistors x 2 GW60KWH-D-10 (No extension cabinet): 1 GW60KWH-D-10: 0
	Wrench x 0: Fire department has "Do Not Touch" label. Wrench x 1: Other	-	-

### 3.2.2.2 BAT-S Series 25.6-56.3kWh High Voltage Battery

#### Battery PACK

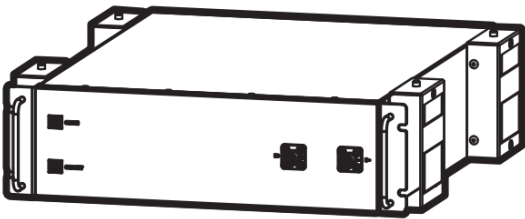
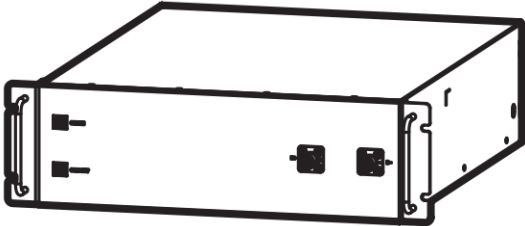



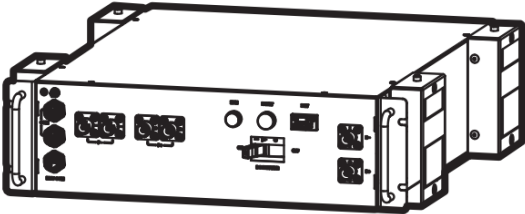
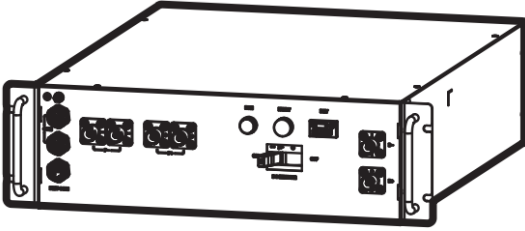

Component	Description
<p>Stacked Installation</p> 	<p>Battery PACK</p> <ul style="list-style-type: none"> <li>• GW25.6-BAT-I-G10: × 5</li> <li>• GW30.7-BAT-I-G10: × 6</li> <li>• GW35.8-BAT-I-G10: × 7</li> <li>• GW40.9-BAT-I-G10: × 8</li> <li>• GW46.0-BAT-I-G10: × 9</li> <li>• GW51.2-BAT-I-G10: × 10</li> <li>• GW56.3-BAT-I-G10: × 11</li> </ul>
<p>Rack Installation</p> 	













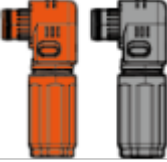

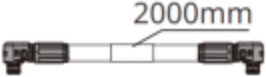
#### PCU

Component	Description
<p>Stack Mounting</p> 	PCU × 1
<p>Rack Mounting</p> 	









## Accessories

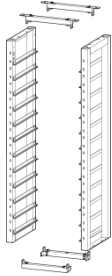

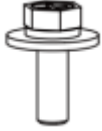
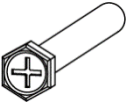
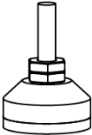
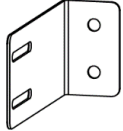
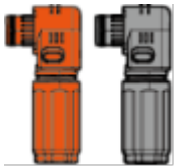
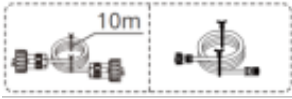
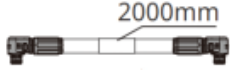
- Stack Mounting

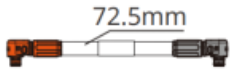
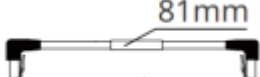
Part	Description	Part	Description
	Ground lock bracket×4		Wall lock bracket×4
	Equipotential bonding strip×15		M5 screw×N
	Cable gland×1		Expansion bolt×8







Part	Description	Part	Description
	Adjustable foot×4		Base×1
	Power connector×2		Battery to inverter communication cable×1
	B- power cable×1		B+ power cable×1
	Internal battery power cable ×N		Internal battery communication cable ×N
	Grounding terminal ×2		M12 expansion bolt ×4
	Nameplate×1		Cable tie×10
	adapter bonnet×1 (Only for machines shipped after April 3, 2026)		Product documentation×1





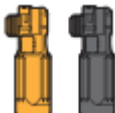
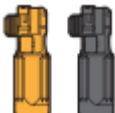
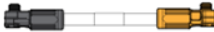

• Rack Mounting

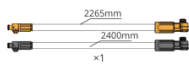
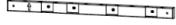
Part	Description	Part	Description
	Battery rack ×1		Rubber pad×4
	M5 screw×N		ST6.3 screw×4
	Adjustable foot×4		Wall mounting bracket×2
	Power connector×2		Battery and inverter communication cable×1
	B- power cable×1		B+ power cable×1
	Battery internal power cable×N		Battery internal communication cable×N
	Grounding terminal×2		M12 expansion bolt×4
	Nameplate×1		Cable tie×10

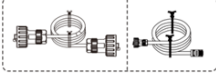
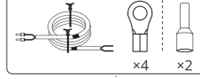

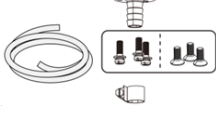

Part	Description	Part	Description
	adapter bonnet×1		Product documentation×1

### 3.2.2.3 BAT-C Series 61.4-112.6kWh Commercial & Industrial Battery System

Component	Description	Component	Description
	battery cabinet×1		Expansion screw×4
	Grounding M5 screw×3		Grounding terminal×3
	Inverter battery connection terminal 25mm <sup>2</sup> ×2		Inter-battery connection terminal 50mm <sup>2</sup> ×2
	Pack series wiring harness×N <ul style="list-style-type: none"> <li>• GW61.4-BAT-AC-G10: ×5</li> <li>• GW92.1-BAT-AC-G10: ×8</li> <li>• GW102.4-BAT-AC-G10: ×9</li> <li>• GW112.6-BAT-AC-G10: ×10</li> </ul>		Pack negative to high-voltage box negative wiring harness×1
	Inverter battery connection (positive)×1 Inverter battery connection (negative)×1		Adapter mounting bracket×2 (For ET100 use only)

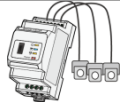
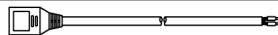

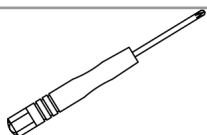



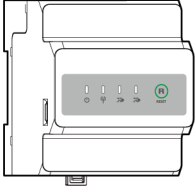

Component	Description	Component	Description
	Battery to inverter communication Ethernet cable×1		Air conditioner power supply wiring harness kit×1
	Lifting eye×4		Cable tie×20
	Air conditioner water pipe kit×1		fireproofing mud×8
	Corrugated pipe connector×6		25mm <sup>2</sup> to 10mm <sup>2</sup> round tube terminal×4
	Product documentation×1	-	-

### 3.2.3 Smart Meter Deliverables (GM3000)

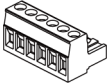
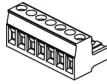
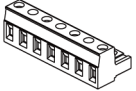
Component	Quantity	Component	Quantity
	Smart meter and CT x 1		2PIN to RJ45 adapter cable x 1
	PIN terminal x 3		USB plug x 1
	screwdriver x 1		Product documentation x 1

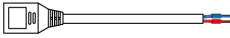
### 3.2.4 Smart Meter Delivery Items GM330&GMK330

#### 3.2.4.1 Attachment List

Component	Description	Component	Description
	Smart Meter x1 GMK330: CT×3; GMK360: CT×6; GM330: CT x 0.		2PIN Communication Terminal x1 For GM330.
	6PIN Communication Terminal x1 For GM330.		7PIN Communication Terminal x1 For GM330.
	Meter Communication Terminal For GMK330/GMK360.		RS485 Communication Terminal x 1
	2PIN Terminal to RJ45 Terminal Adapter Cable x 1		screwdriver x1
	PIN terminal GMK330/GMK360: x 5 ; GM330: x 6.		Product Documentation x 1

### 3.3 Storage

## NOTICE

[1] The storage time is calculated starting from the SN date on the battery's outer packaging. Charge-discharge maintenance is required after exceeding the storage period. (Battery maintenance time = SN date + charge-discharge maintenance cycle). For the method to view the SN date, refer to: [11.4.SN Code Meaning\(Page 366\)](#).

[2] After passing the charge-discharge maintenance, if the outer box has a Maintaining Label, please update the maintenance information on the Maintaining Label. If there is no Maintaining Label, please record the maintenance time and battery SOC yourself and keep the data properly for maintaining maintenance records.

If the equipment is not put into use immediately, please store it according to the following requirements. After long-term storage, the equipment must be inspected and confirmed by qualified personnel before it can be used again.

1. If the inverter has been stored for more than two years or has not been operated for more than 6 months after installation, it is recommended to be inspected and tested by qualified personnel before being put into use.
2. To ensure the good electrical performance of the internal electronic components of the inverter, it is recommended to power it on once every 6 months during storage. If it has not been powered on for more than 6 months, it is recommended to be inspected and tested by qualified personnel before being put into use.
3. To ensure battery performance and service life, it is recommended to avoid long-term idle storage. Prolonged storage may cause deep discharge of the battery, leading to irreversible chemical degradation, capacity decay, or even complete failure. Timely use is recommended. If the battery requires long-term storage, please maintain it according to the following requirements:

Battery	Initial SOC Range for Battery Storage	Recommended Storage Temperature	Charge/Discharge Maintenance Cycle[1]	Battery Maintenance Method[2]
Lynx C Series 60kWh Commercial & Industrial Battery System	30%~40%	0~35°C	-20~0°C, ≤1 month 0~+35°C, ≤6 months 35~+45°C, ≤1 month	Please consult your dealer or after-sales service center for the maintenance method.
BAT-S Series 25.6-56.3kWh High Voltage Battery	30%~40%	0~35°C	-20~35°C (≤12 months) 35~+45°C (≤6 months)	
BAT Series 61.4-112.6kWh Commercial & Industrial Battery System				

### Packaging Requirements:

Ensure the outer packaging box is not removed and the desiccant inside the box is not lost.

### Environmental Requirements:

1. Ensure the equipment is stored in a cool place, avoiding direct sunlight.
2. Ensure the storage environment is clean, with appropriate temperature and humidity ranges, and free from condensation. If condensation is observed on the equipment ports, do not install the equipment.
3. Ensure the equipment is stored away from flammable, explosive, corrosive, and other hazardous materials.

### Stacking Requirements:

1. Ensure the stacking height and orientation of the inverter comply with the instructions on the packaging box label.
2. Ensure there is no risk of the stacked inverters tipping over.

# 4 Installation



When performing device installation and electrical connections, please use the components delivered with the shipment. Otherwise, any resulting device damage will not be covered under warranty.

## 4.1 System Installation and Commissioning Procedure

Steps	1 Installation		2 PE		3 Battery				4 COM	
Battery	Lynx C 60kWh C&I	BAT 61.4-112.6kWh C&I	Lynx C 60kWh C&I	BAT 61.4-112.6kWh C&I	Lynx C 60kWh C&I	BAT 61.4-112.6kWh C&I	BAT 61.4-112.6kWh C&I	Lynx C 60kWh C&I	BAT 61.4-112.6kWh C&I	BAT 61.4-112.6kWh C&I
Tools	1 D: 80mm Φ: 14mm 2 M12 50N-m		M5 4.5N-m	M5 4N-m	M6 6N-m M8 10N-m	Recommend: YQK-70 M5 4.5-6N-m	Crimping tool			
Steps	1 Installation				2 PE	3 Battery	4 COM			
Battery	BAT 25.6-56.3kWh HV									
Tools	1 M5 4N-m 2 D: 60mm Φ: 8mm 3 M6 6N-m		M5 4N-m		D: 80mm Φ: 14mm M12 50N-m	M5 4N-m ST6.3 10-11N-m	M5 4N-m	Crimping tool		
Steps	1 Installation	2 PE	3 PV	4 Battery	5 AC	6 COM	7 Communication module			
Inverter							Wi-Fi Kit	WiFi/LAN Kit-20	Ezlink3000	
Tools	M5 4.5N-m M5 1.2-2N-m	M5 1.2-2N-m	Recommend: PV-CZM-61100	Recommend: VXC9	M5 2-3N-m M6 3-4N-m	M4 1.5N-m	4G Kit-CN LS4G Kit-CN 4G Kit-CN-G20 4G Kit-CN-G21			
Steps	1 Installation		2 Cable Connections			3 Power	4 Commissioning			
Smart meter	GM3000	GM330/GMK330	GM3000	GMK330	GM330	AC breaker	SolarGo APP SEMS Portal APP or SEMS Portal WEB			
		GM330: CT×0 GMK330: CT×3	1.2-2N-m							

## 4.2 Installation Requirements

### 4.2.1 Installation Environment Requirements

#### NOTICE

If installed in an environment below 0°C, the battery may become unable to recharge and recover energy after being depleted, resulting in battery undervoltage protection.

GW60KWH-D-10: Charging temperature range:  $0 < T < 55^{\circ}\text{C}$ ; Discharging temperature range:  $-25 < T < 55^{\circ}\text{C}$

1. The equipment must not be installed in flammable, explosive, corrosive, or similar environments.
2. The temperature and humidity of the installation environment must be within a suitable range.
3. The installation location must be out of reach of children and avoid easily accessible positions.
4. The enclosure temperature of the Inverter may exceed 60°C during operation. Do not touch the enclosure before it cools down to prevent burns.
5. The Inverter should be installed away from direct sunlight, rain, snow accumulation, and similar conditions. It is recommended to install it in a sheltered location; a sunshade can be constructed if necessary.
6. Adverse environmental conditions such as direct sunlight and high temperatures may cause the Inverter's output power to derate.
7. The installation space must meet the equipment's ventilation, heat dissipation, and operational space requirements.
8. The installation environment must satisfy the equipment's ingress protection (IP) rating.
  - Inverters and Smart Communication Sticks are suitable for both indoor and outdoor installation;
  - Electric meters are suitable for indoor installation;
  - Lynx C Series 60kWh Commercial & Industrial Battery System and BAT-C Series 61.4-112.6kWh Commercial & Industrial Battery System are suitable for both indoor and outdoor installation. The BAT-S Series 25.6-56.3kWh High Voltage Battery is suitable for indoor installation and must be kept ventilated.
9. When installing equipment indoors, ensure there are no obstacles within a 10-meter diameter of the installation location.
10. During construction and installation, ensure the bottom of the equipment is higher

than the local historical highest water level.

11. The installation height of the equipment should facilitate operation and maintenance, ensuring indicator lights, all labels are easily visible, and wiring terminals are easily accessible.
12. The installation altitude of the equipment must be lower than the maximum operating altitude.
13. The battery system must be installed on a flat, dry ground surface. It must not be placed in a recessed or inclined area and is strictly prohibited from being installed on ground prone to water accumulation or subsidence. Ensure the ground can support the weight of the battery system.
14. Consult the equipment manufacturer before installing equipment outdoors in salt damage areas. Salt damage areas mainly refer to regions within 500m of the coastline. The affected area is related to sea wind, precipitation, terrain, and other conditions.
15. Keep away from strong magnetic field environments to avoid electromagnetic interference. If there are radio stations or wireless communication devices operating below 30MHz near the installation site, install the equipment according to the following requirements:
  - Inverter: Add a ferrite core with multiple windings on the Inverter's DC input lines or AC output lines, or add a low-pass EMI filter; OR maintain a distance of over 30m between the Inverter and the wireless electromagnetic interference device.
  - Other Equipment: Maintain a distance of over 30m between the equipment and the wireless electromagnetic interference device.
16. The length of DC and communication cables between the battery and the Inverter must be less than 3m. Ensure the installation distance between the Inverter and the battery meets the cable length requirement.

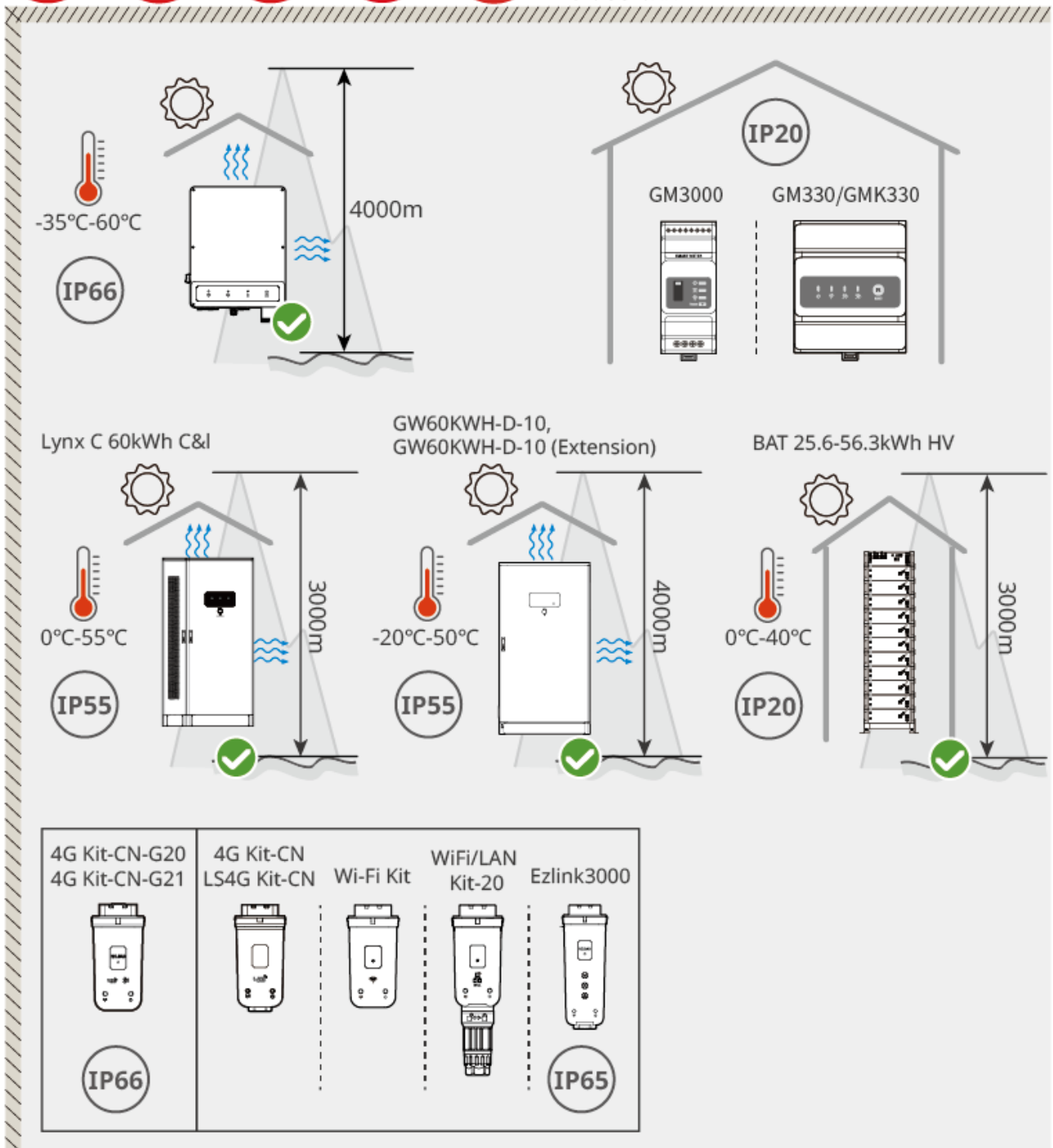

ET3010INT0007

## 4.2.2 Foundation Installation Requirements

1. The foundation material must be C25 plain concrete hardened ground or other

non-combustible surfaces.

- The foundation must have pre-reserved cable trenches or outlet holes to facilitate equipment cabling.
- Equipment (including height, embedded expansion screw parts, conduit, etc.) should be adjusted according to the process and site conditions.
- The top elevation of the equipment foundation can be adjusted based on the equipment and actual site requirements.
- Ensure the equipment is installed level, not tilted or inverted.
- Cable Trench Requirements:
  - If the equipment uses bottom cable entry, the trench must have dust-proof and rodent-proof designs to prevent foreign objects from entering.
  - The trench must have waterproof and moisture-proof designs to prevent cable aging and short circuits, which could affect normal equipment operation.
  - Due to the thickness of equipment cables, sufficient space for cables must be reserved during trench design to ensure smooth, non-abrasive cable connections.

## NOTICE

The conduit can be replaced on-site with 4 PVC pipes with a diameter of 125mm. Indoor environments do not require pre-installed conduits.

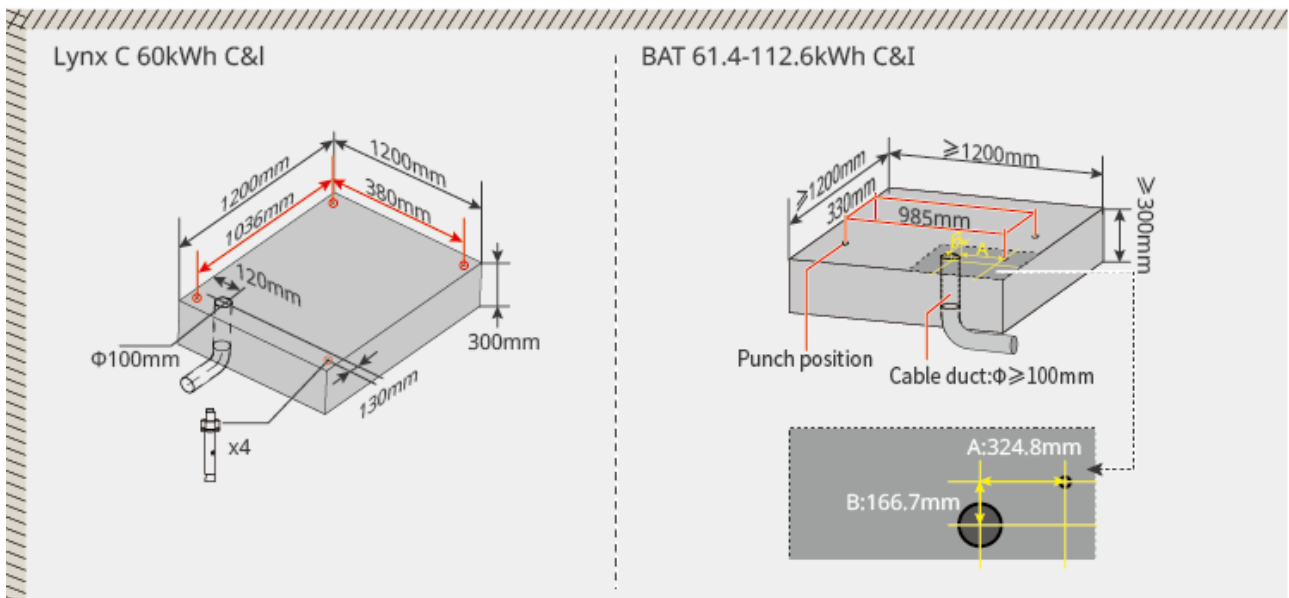

LXC6010INT0001

### 4.2.3 Installation Space Requirements

When installing devices in the system, sufficient space should be reserved around the devices to ensure adequate installation and heat dissipation space.

#### NOTICE

The specific values of the battery installation space can be adjusted based on the actual installation scenario and local regulations.

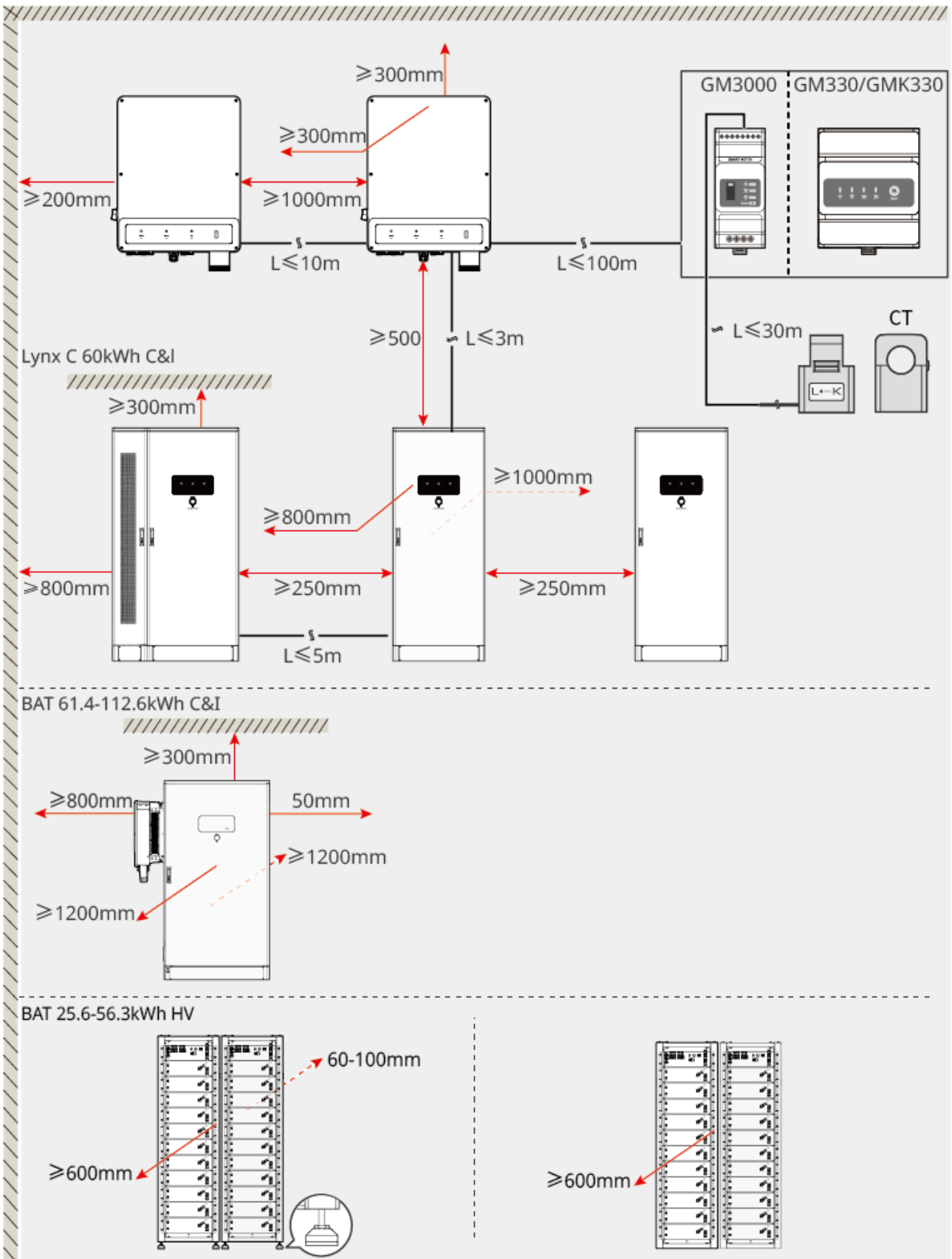

ET3010INT0008

## 4.2.4 Tool Requirements

### NOTICE



It is recommended to use the following installation tools. When necessary, other auxiliary tools can be used on-site.

### Installation Tools

Tool Type	Description	Tool Type	Description
	diagonal plier		RJ45 crimping tool
	wire stripper		YQK-70 hydraulic pliers
	VXC9 hydraulic pliers		Level bar
	open-end wrench		PV terminal crimping tool PV-CZM-61100
	hammer drill (drill bit Φ8mm)		torque wrench M5/M6/M8/M12/M16/ M18/M22
	rubber hammer		socket wrench

Tool Type	Description	Tool Type	Description
	marker pen		multimeter range $\leq 1100V$
	heat shrink tubing		heat gun
	cable tie		vacuum cleaner
	Level bar		

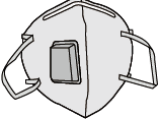
### Personal Protective Equipment

Tool Type	Description	Tool Type	Description
	Insulated gloves, protective gloves		Dust mask
	goggle		Safety shoes

## 4.3 Equipment Handling

## WARNING

1. During operations such as transportation, handling, and installation, it is necessary to comply with the laws, regulations, and relevant standard requirements of the country or region where the equipment is located.
2. Before installation, the equipment must be moved to the installation site. To avoid personal injury or equipment damage during the moving process, please note the following:
  - Ensure an adequate number of personnel corresponding to the equipment's weight to prevent it from exceeding the human lifting capacity and causing injury.
  - Wear safety gloves to avoid injury.
  - Ensure the equipment remains balanced during movement to prevent dropping and tipping over.
  - During movement, ensure all cabinet doors are securely locked.

## NOTICE

- The equipment can be transported to the installation site using either hoisting or a forklift.
- When moving the equipment using the hoisting method, please use flexible slings or straps, with a single strap load-bearing capacity of  $\geq 2t$ .
- When using a forklift to move the equipment, the forklift's load-bearing capacity must be  $\geq 2t$ .

### • Lynx C Series 60kWh Industrial & Commercial Battery System

#### Forklift Transport Method One

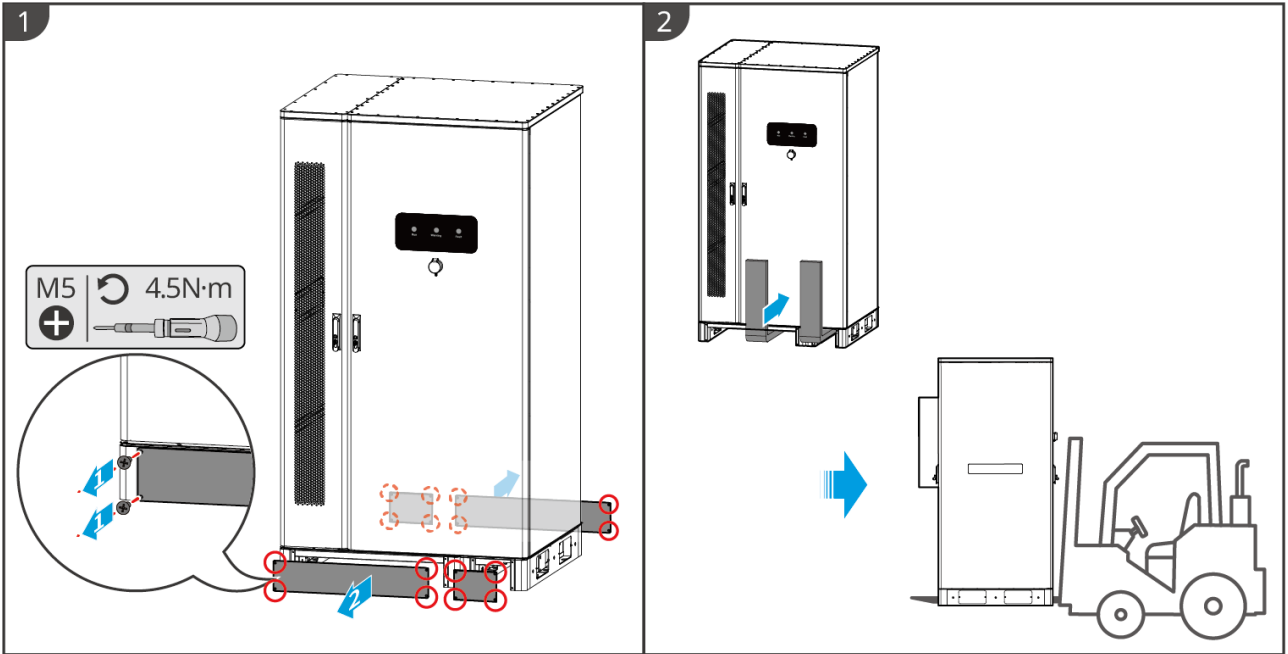

### Forklift Transport Method Two

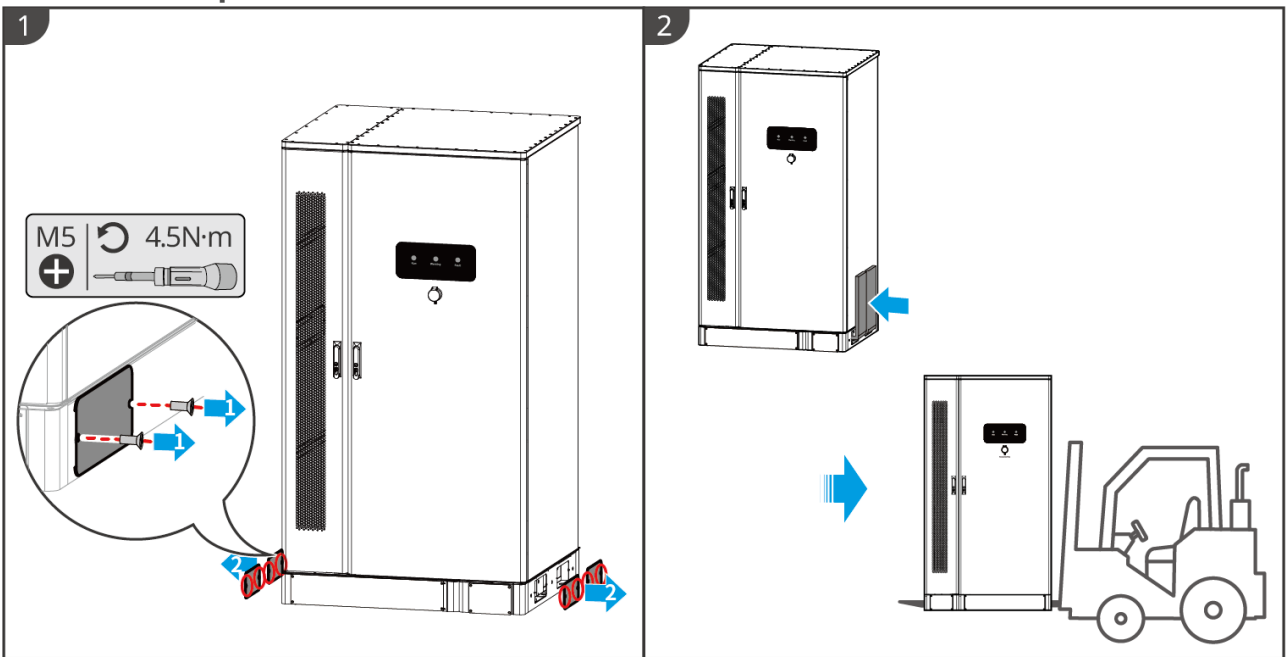

### Hoisting Transport:

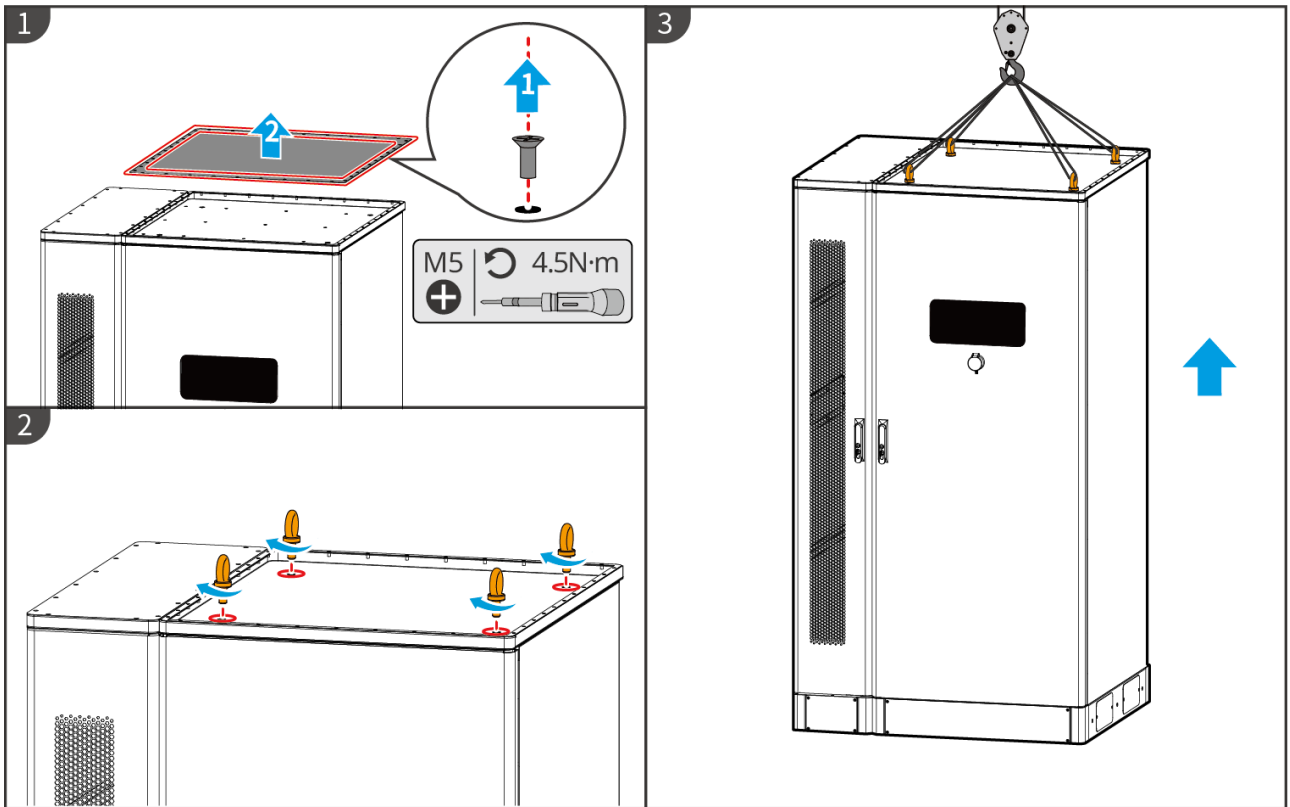

LXC6010INT0004

• **BATSeries 25.6-56.3kWh High Voltage Battery**

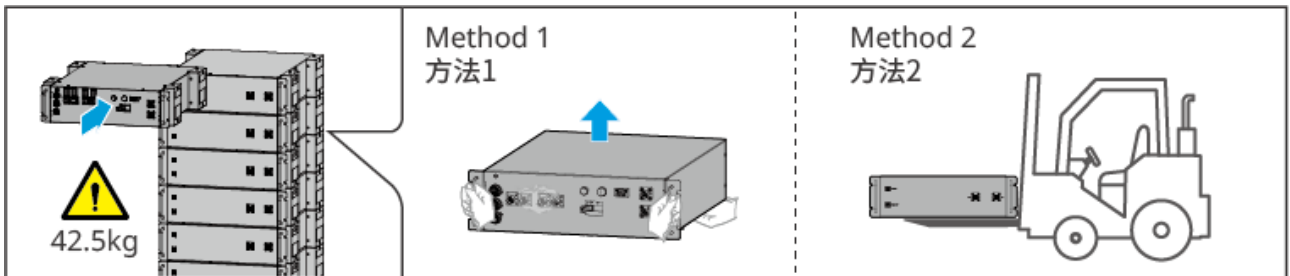

BAT10INT0032

• **BATSeries 61.4-112.6kWh Industrial & Commercial Battery System**

**NOTICE**

- Before moving the equipment with a forklift, remove the baffle.
- During shipment, the battery system is secured to the pallet with bottom screws. Before installation, remove the pallet.

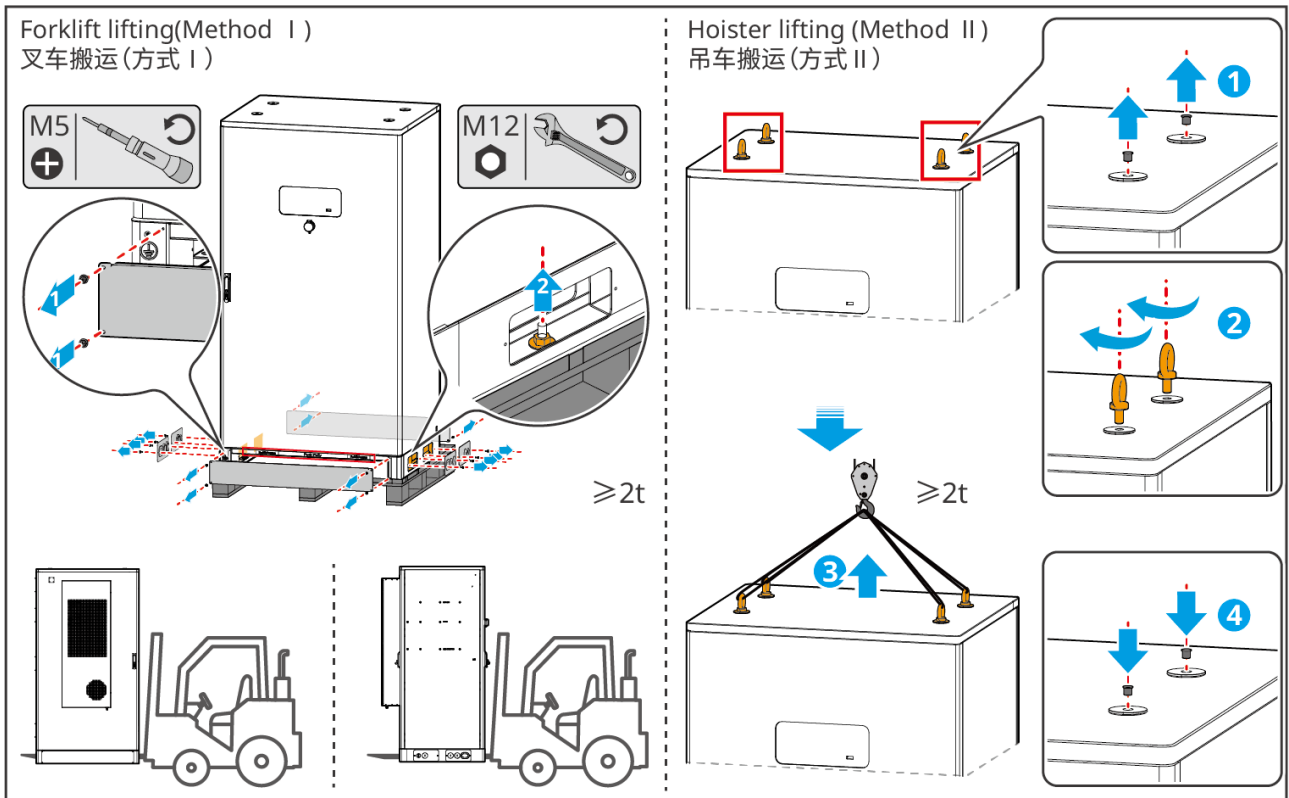

BAT10INT0003

## 4.4 Installing the Inverter

### Inverter installed in the battery system cabinet

#### CAUTION

Ensure the inverter is installed securely to prevent it from falling and causing injury.

1. Fix the inverter backplate bracket on the battery system cabinet.
2. (Optional) Use the DC switch lock to lock the DC switch in the "OFF" state, and hang the inverter on the backplate. The DC switch lock is user-provided; please ensure the aperture of the DC switch lock meets the requirements.
3. Tighten the screws on both sides to secure the backplate and inverter, ensuring the inverter is installed firmly.

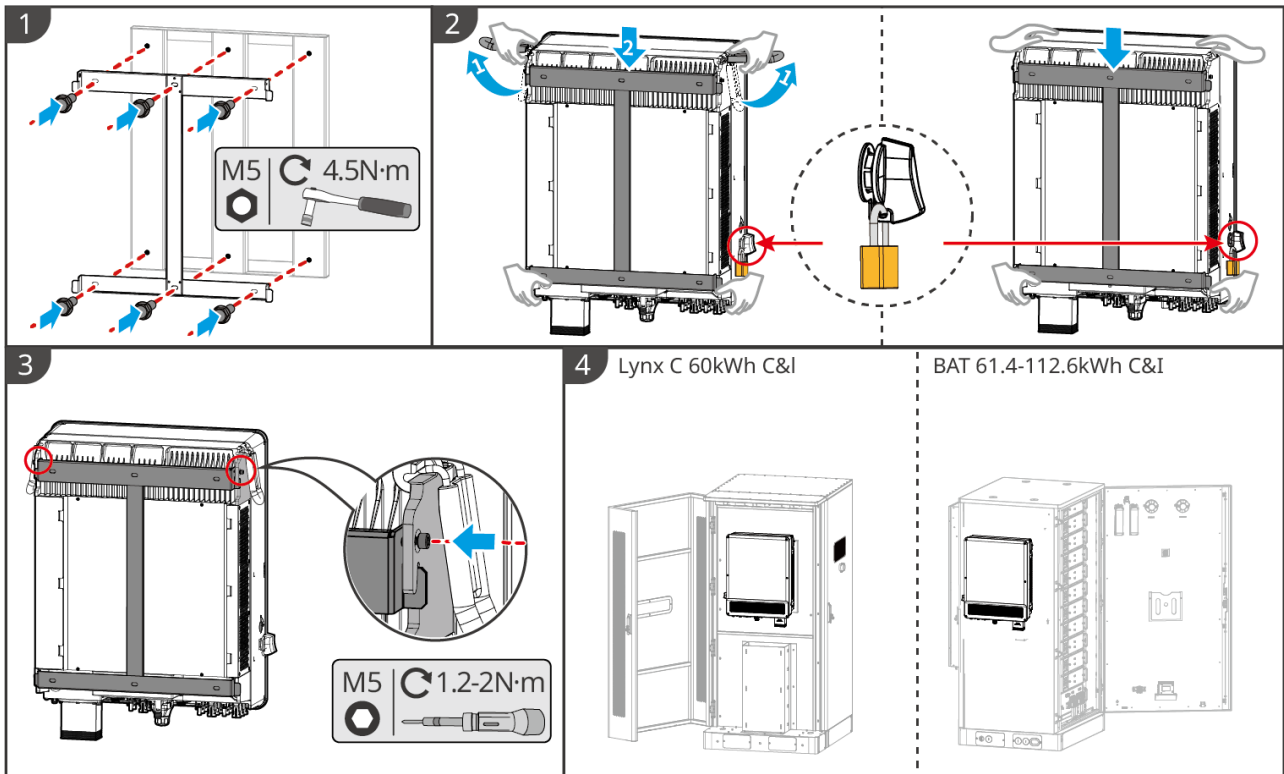

ET3010INT0006

## Inverter installed on the wall

### CAUTION

- When drilling, ensure the drilling location avoids water pipes, cables, etc. inside the wall to prevent danger.
- When drilling, please wear safety goggles and a dust mask to avoid inhaling dust into the respiratory tract or getting it into the eyes.
- Ensure the inverter is installed securely to prevent it from falling and injuring people.

1. Place the backplate horizontally on the wall surface, and use a marker pen to mark the drilling positions.
2. Use an impact drill to drill holes.
3. Use expansion screws to fix the inverter backplate bracket on the wall.
4. Use the DC switch lock to lock the DC switch in the "OFF" state, and hang the inverter on the backplate. (Optional) For Australia only, the DC switch lock is user-provided; please ensure the aperture of the DC switch lock meets the requirements.

5. (Optional) Lower the handle.
6. Tighten the screws on both sides to secure the backplate and inverter, ensuring the inverter is installed firmly.

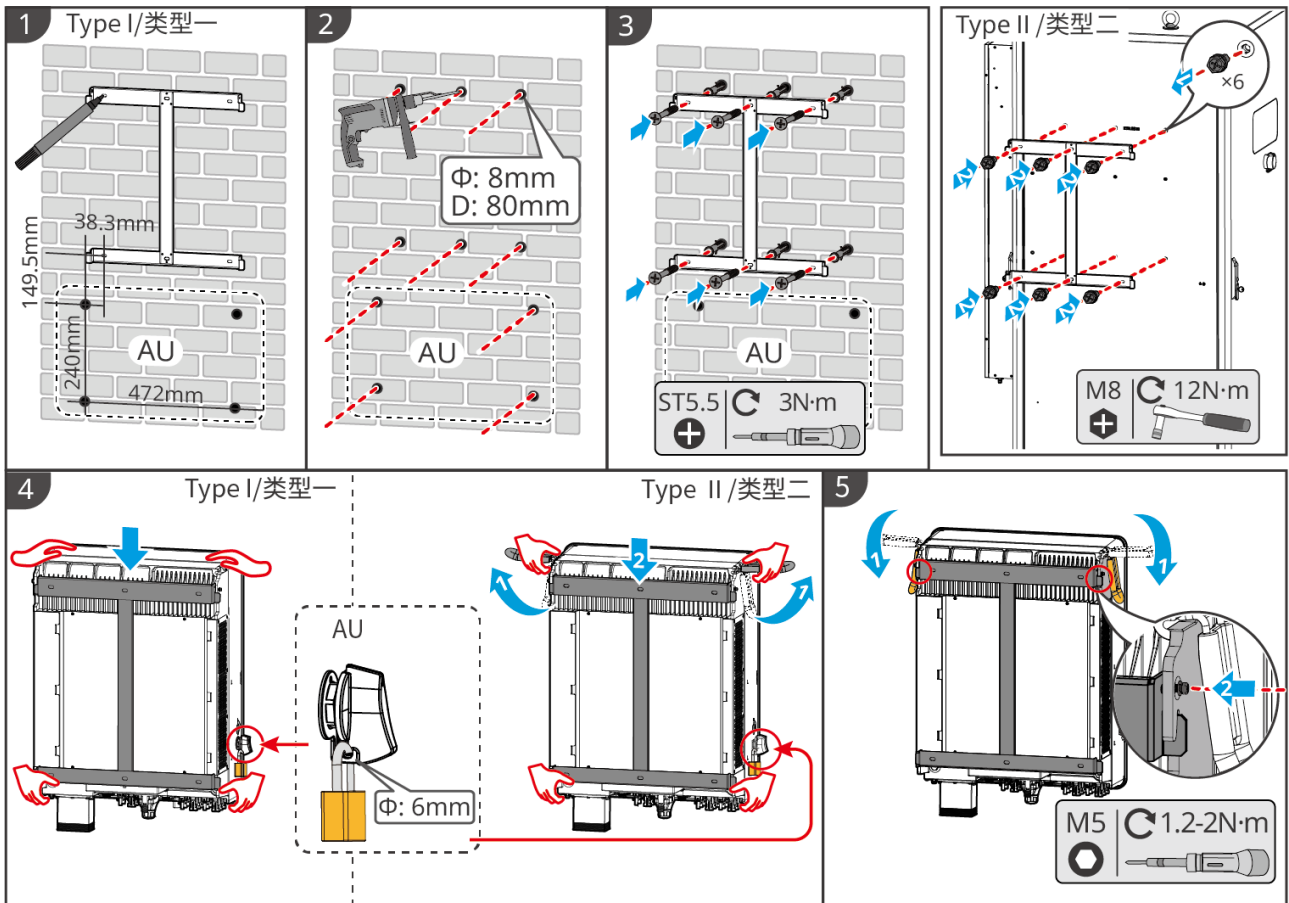

ET3010INT0002

### Installing the Protective Cover (Australia Only)

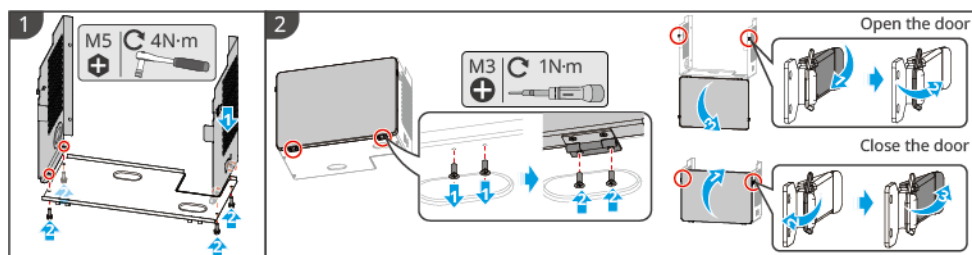

ET3010INT0012

- Step1:** Assemble the protective cover.
- Step2:** Install the front cover.
- Step3:** Fix the protective cover on the wall/side of the battery cabinet, and install the circuit breaker, waterproof box, and bridge according to local regulations. For specific requirements, please refer to the table below.

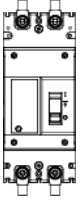
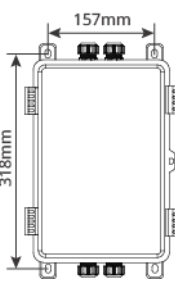
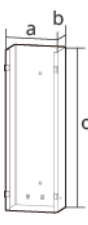
Equipment		Recommended Model/Specifications	Description
breaker		<p>Select according to local laws and regulations</p> <ul style="list-style-type: none"> <li>• 2P DC switch</li> <li>• Rated Current <math>\geq 63A</math></li> <li>• Nominal Voltage <math>\geq 1000V</math></li> </ul>	User to provide.
Water proof Box		<p>Waterproof rating &gt; IP65</p> <p>Hole spacing requirements:</p> <ul style="list-style-type: none"> <li>• Left-right hole spacing: 157mm</li> <li>• Top-bottom hole spacing: 318mm</li> </ul> <p>Style and dimensions are for reference only</p>	<p>User to provide.</p> <p>If the hole spacing of the waterproof box does not meet the requirements and it cannot be fixed on the battery cabinet, please prepare an installation plate. First, drill holes in the installation plate as required and fix it on the battery cabinet, then fix the waterproof box on the installation plate.</p>
Cable Tray		<p>a: 250mm</p> <p>b: 150mm</p> <p>c: 510mm</p> <p>Style is for reference only</p>	User to provide.

## 4.5 Installing the Battery System

**! WARNING**

- Before installation, check that the ground is level and not slanted.
- Ensure the energy storage system is placed vertically and flush against the ground, with no risk of tipping over.

### 4.5.1 Open the Cabinet Door

**! WARNING**

- Do not open the cabinet door during handling and installation.
- Close the cabinet door after system installation, wiring, and debugging.

**Step 1:** Use the key to unlock the cabinet door.

**Step 2:** Turn the door handle to open the cabinet door.

- **Lynx C Series 60kWh Commercial & Industrial Battery System**

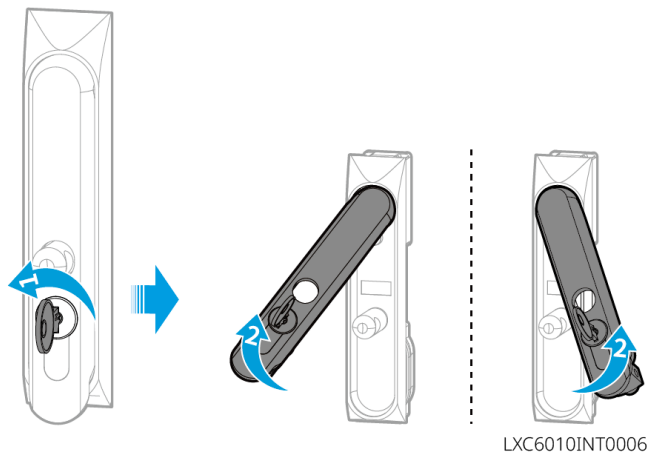

- **BAT-C Series 61.4-112.6kWh Commercial & Industrial Battery System**

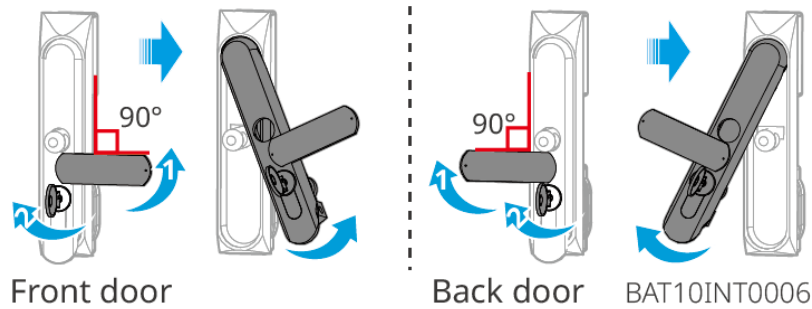

## 4.5.2 Installing the Lynx C Series 60kWh Commercial & Industrial Battery System

**Step 1:** Use a marker pen to mark the drilling locations on a level ground.

**Step 2:** Use an impact drill with a 14mm diameter drill bit to create holes approximately 80mm deep, and install the expansion bolts.

**Step 3:** Move the battery system to the hole positions and tighten the expansion bolts using a socket wrench.

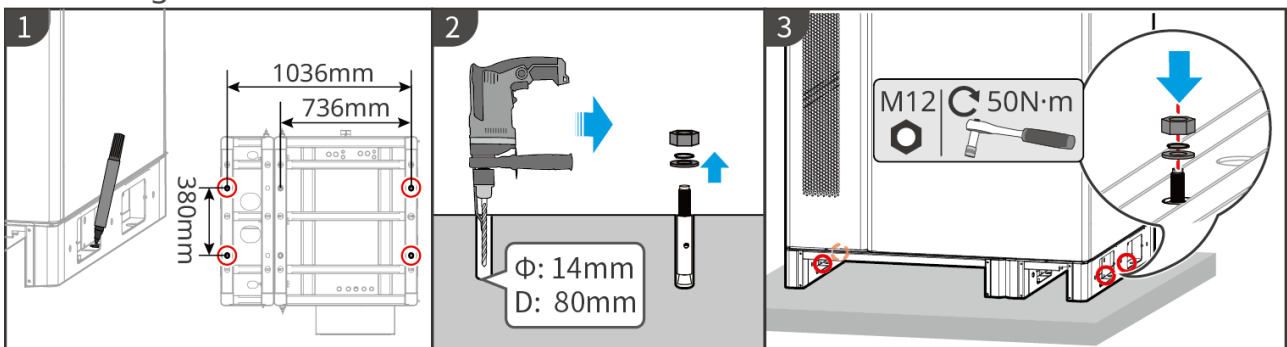

LXC6010INT0005

## 4.5.3 Installing BAT-S Series 25.6-56.3kWh High-Voltage Battery

### • Stacked Installation

**Step 1:** Install adjustable feet under the base. The adjustable foot height range is 35-45mm.

**Step 2:** Secure the floor-locking bracket onto the base.

**Step 3:** Use a pen to mark the drilling positions for expansion bolts on the floor.

**Step 4:** Install the expansion bolts.

**Step 5:** Secure the floor-locking bracket to the floor using the expansion bolts.

**Step 6:** Stack the battery PACKS. Pre-tighten the wall-locking brackets on the first and last battery PACKS.

**Step 7:** Use a pen to mark the drilling positions for expansion bolts on the wall. Secure the wall-locking brackets with expansion bolts, then tighten the wall-locking

brackets on the battery PACKs.

**Step 8:** Place the high-voltage box.

**Step 9:** Install the equipotential bonding strap and the cable bushing.

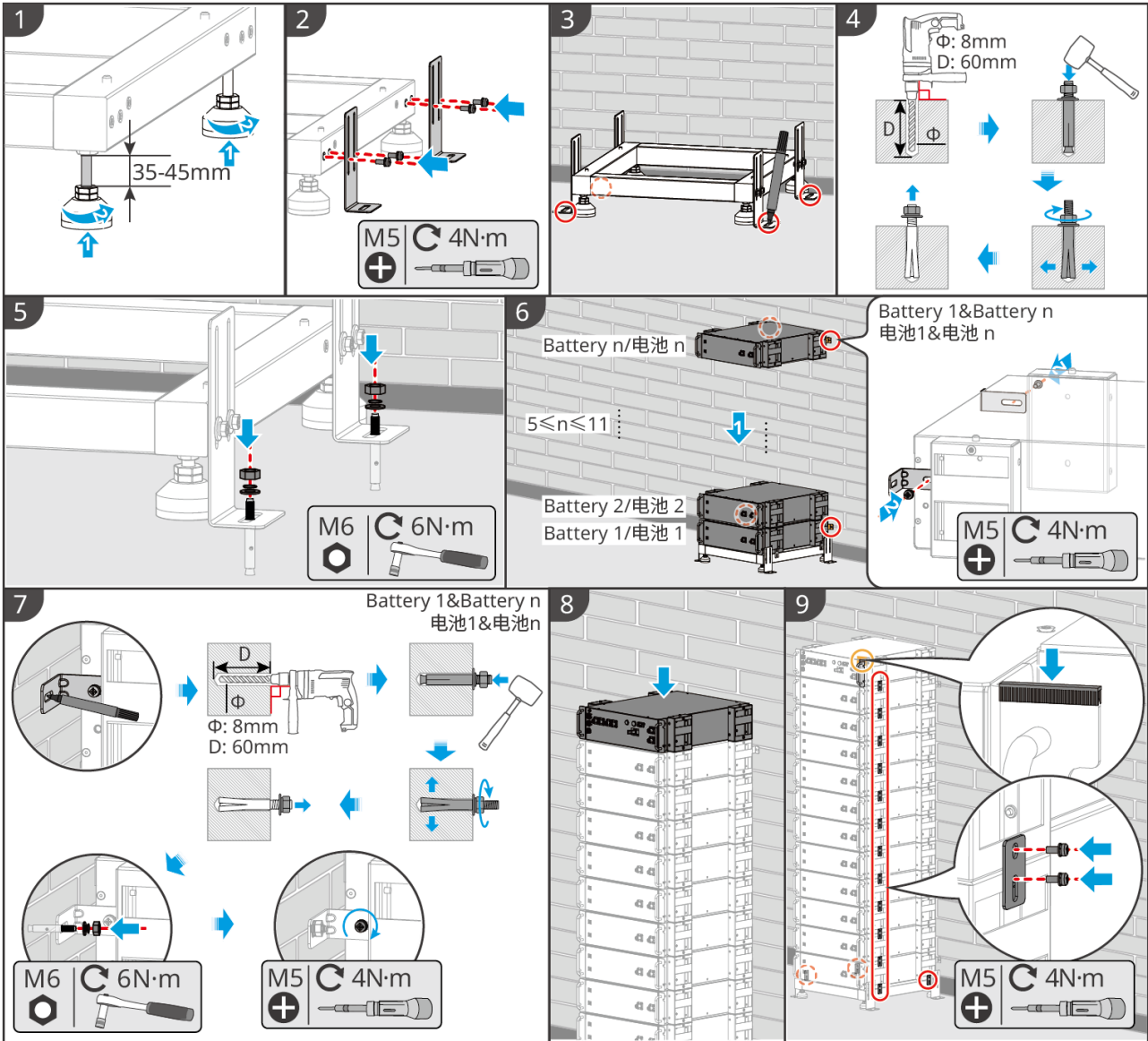

BAT10INT0021

## • Battery Rack Installation

### Installing the Battery Rack

**Step1:** Lay the rack flat. Align the holes according to the serial number silk-screen printing and secure them using M5 screws.

**Step2:** Place the rack vertically according to the arrow markings.

## Securing the Battery Cabinet

- **Type I**

**Step3:** Use a marker pen to mark the drilling positions for expansion bolts on the level ground.

**Step4:** Install the expansion bolts and secure the battery rack to the level ground using them.

- **Type II**

**Step3:** Lay the rack down horizontally and install adjustable feet at the bottom of the rack.

**Step4:** Place the rack vertically. Secure the rack to the wall using wall-locking brackets.

## Installing the High-Voltage Box and Battery PACKs

**Step5:** Push the high-voltage box and battery PACKs into the rack in sequence, and attach labels on the side of the rack.

**Step6:** Secure the high-voltage box and battery PACKs using M5 screws.

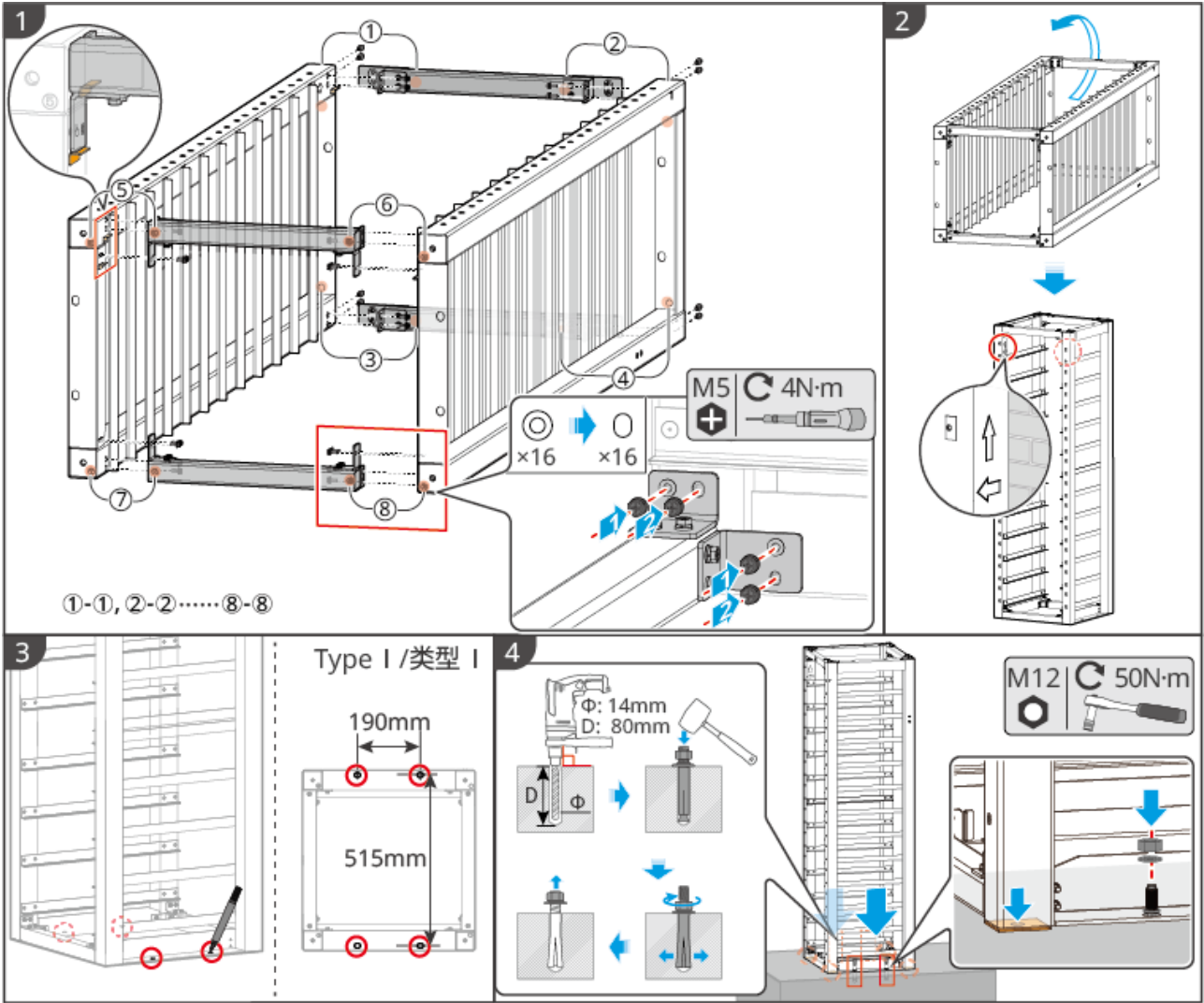

BAT10INT0020

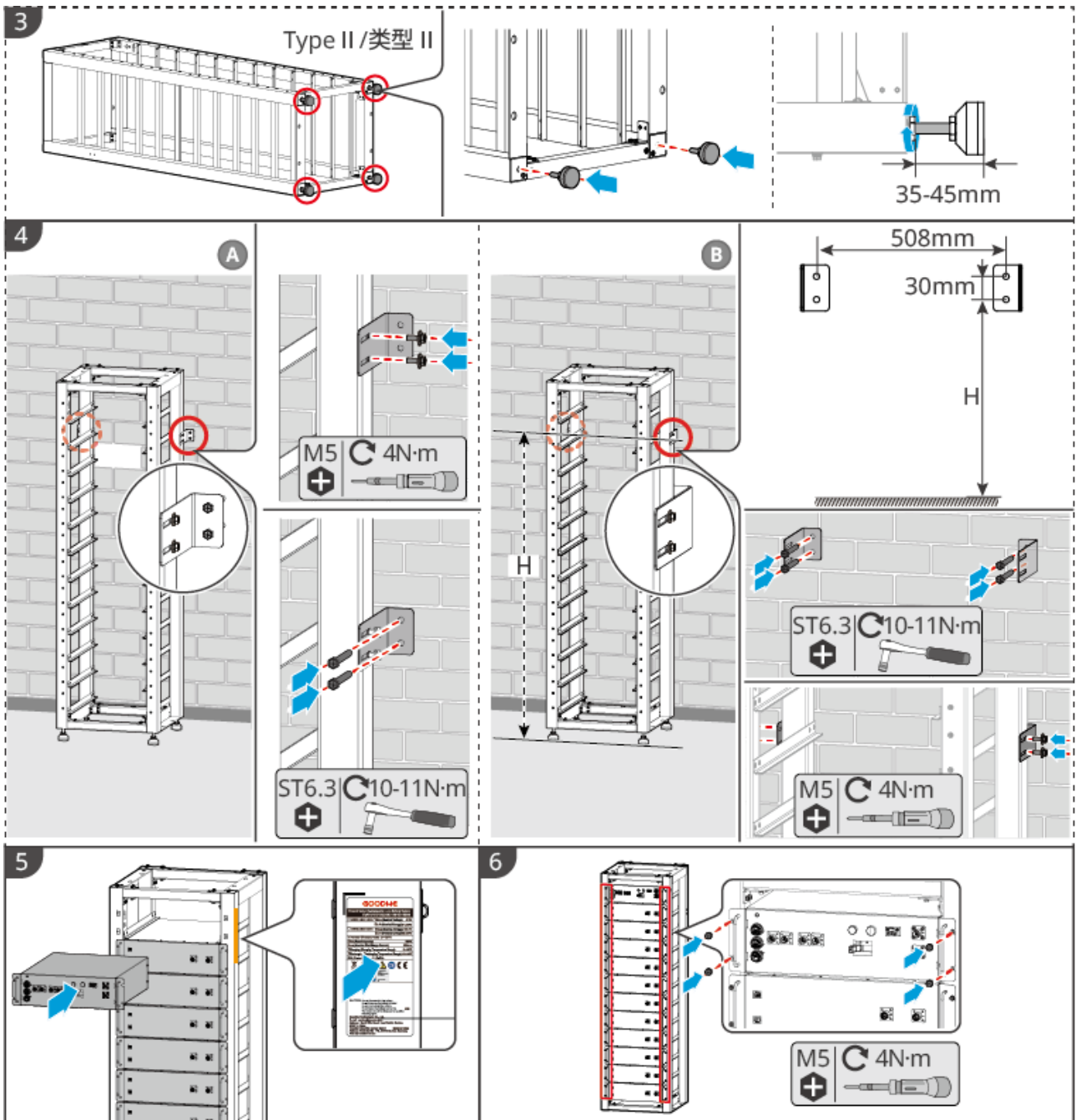

BAT10INT0031

#### 4.5.4 Installing BAT-C Series 61.4-112.6kWh Commercial & Industrial Battery System

**Step 1:** Secure the battery system to the foundation.

1. Mark the drilling positions according to the dimensions shown in the diagram.

2. Use an impact drill to create the holes and install expansion bolts.
3. Move the battery rack to the hole positions and use the expansion bolts to fasten the battery to the foundation.

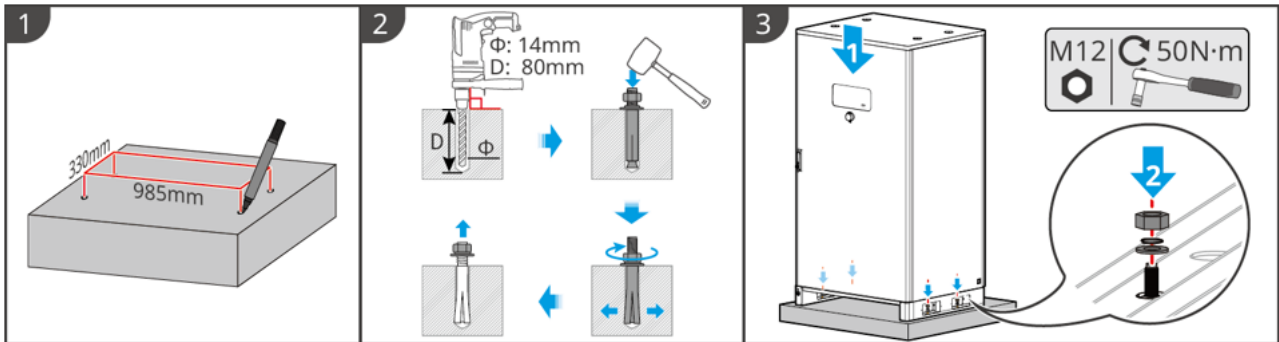

BAT10INT0005

**Step 2:** Remove the protective covers from the smoke and temperature alarm sensors. The smoke sensor and temperature sensor alarms are shipped with protective covers, which must be removed for the alarms to function properly.

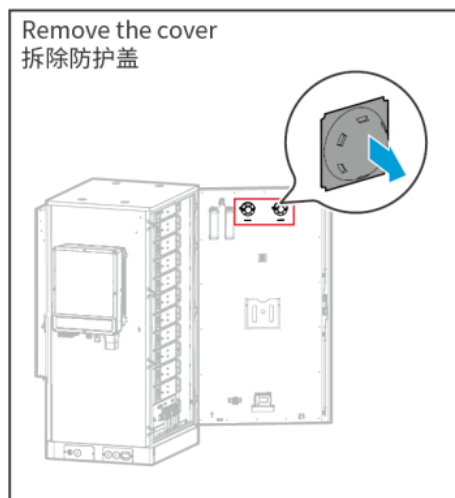

BAT10INT0016

**Step 3:** Install the air conditioning drain pipe.

1. Install the air conditioning drain pipe connector.
2. Secure the air conditioning drain pipe to the connector.

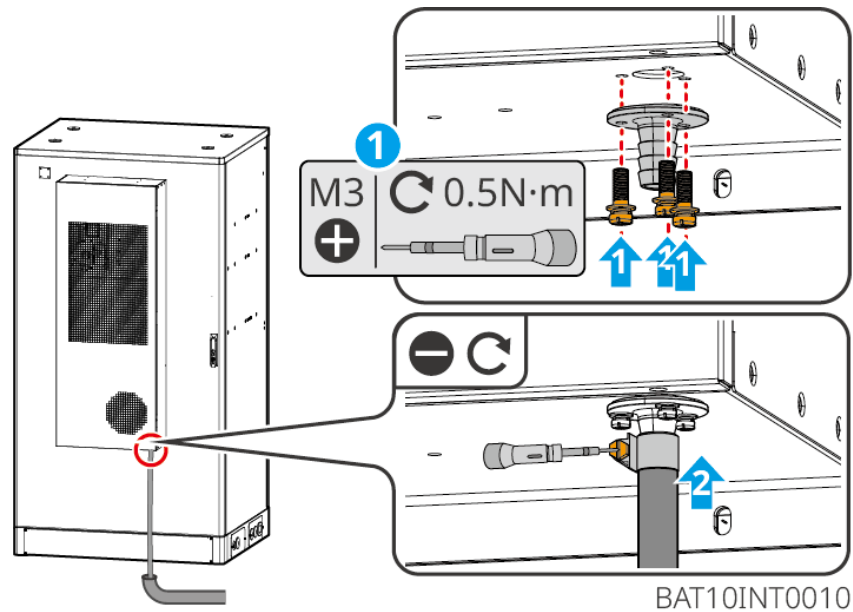

## 4.6 Installing the Smart Meter

### **!WARNING**

In areas with lightning hazard, if the meter cable length exceeds 10m and the cable is not routed using grounded metal conduit, it is recommended to install external lightning protection devices.

### GM3000

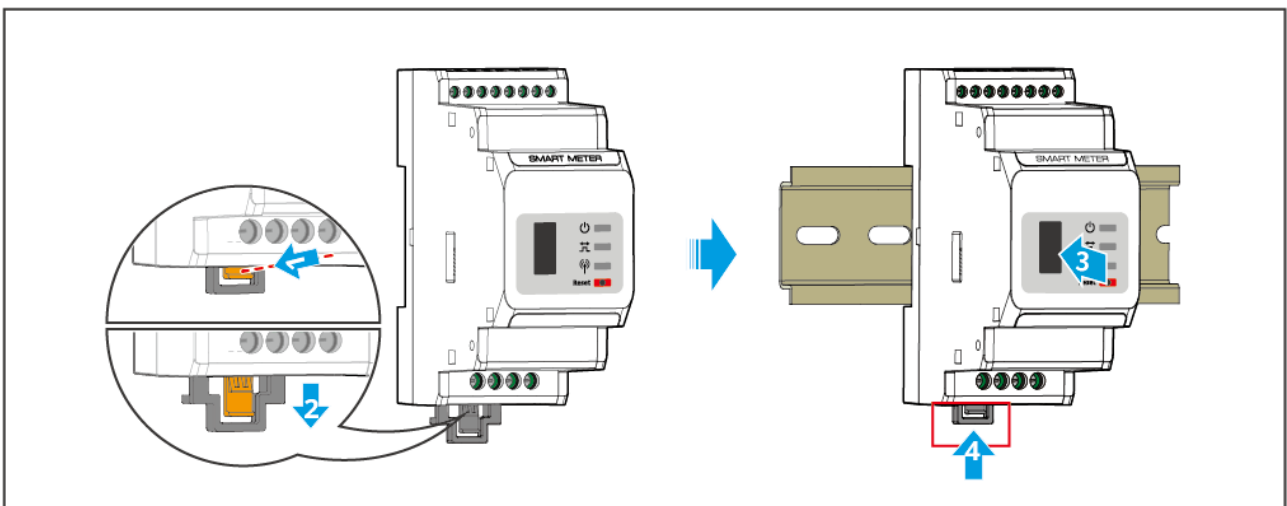

### GM330&GMK330

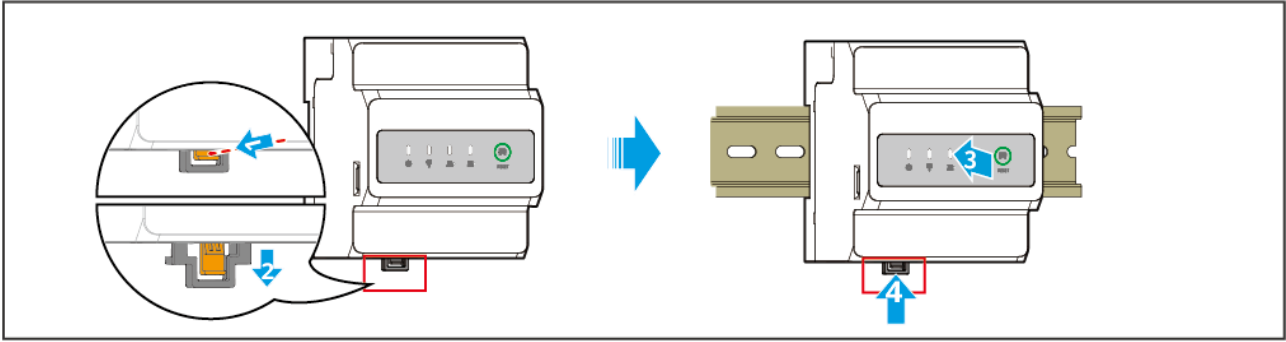

GMK10INT0003

# 5 System Wirings

## DANGER

- The installation, routing, and connection of cables must comply with local laws, regulations, and standard requirements.
- All operations during electrical connection, as well as the specifications of cables and components used, must meet local legal and regulatory requirements.
- Before performing electrical connections, disconnect the DC switch and AC output switch of the device to ensure it is powered off. Live operation is strictly prohibited, otherwise it may lead to DANGER such as electric shock.
- Cables of the same type should be bundled together and separated from different types of cables. It is prohibited to intertwine or cross-arrange them.
- If the cable is subjected to excessive tension, it may lead to poor connections. When wiring, leave a certain length of cable slack before connecting to the inverter terminal ports.
- When crimping terminals, ensure that the conductor part of the cable is in full contact with the terminal. Do not crimp the cable insulation together with the terminal, as this may cause the device to fail to operate, or after operation, due to unreliable connections leading to heating and damage to the inverter terminal block, among other conditions.

## NOTICE

- When performing electrical connections, wear personal protective equipment such as safety shoes, protective gloves, and insulating gloves as required.
- Only qualified personnel are permitted to perform electrical connection operations.
- The cable colors shown in the diagrams in this document are for reference only. Actual cable specifications must comply with local regulations.
- For parallel systems, please adhere to the safety precautions in the user manuals corresponding to the relevant products within the system.

## 5.1 System Wiring Electrical Block Diagram

## NOTICE

- Depending on regional regulatory requirements, the wiring methods for the N and PE lines of the inverter's ON-GRID and BACK-UP ports may differ. Please comply with local regulations.
- The inverter's ON-GRID AC port has a built-in relay. When the inverter is in off-grid mode, the built-in ON-GRID relay is open; when the inverter is in grid-connected operation mode, the built-in ON-GRID relay is closed.
- After the inverter is powered on, the BACK-UP AC port is live. If maintenance is required on the BACK-UP Loads, please power down the inverter to avoid the risk of electric shock.

### **N and PE lines are connected together in the distribution box**

## NOTICE

- To maintain neutral integrity, the neutral wires on the grid-connected side and the off-grid side must be connected together; otherwise, the off-grid function cannot operate normally.
- The diagram below illustrates the grid system for regions such as Australia and New Zealand:

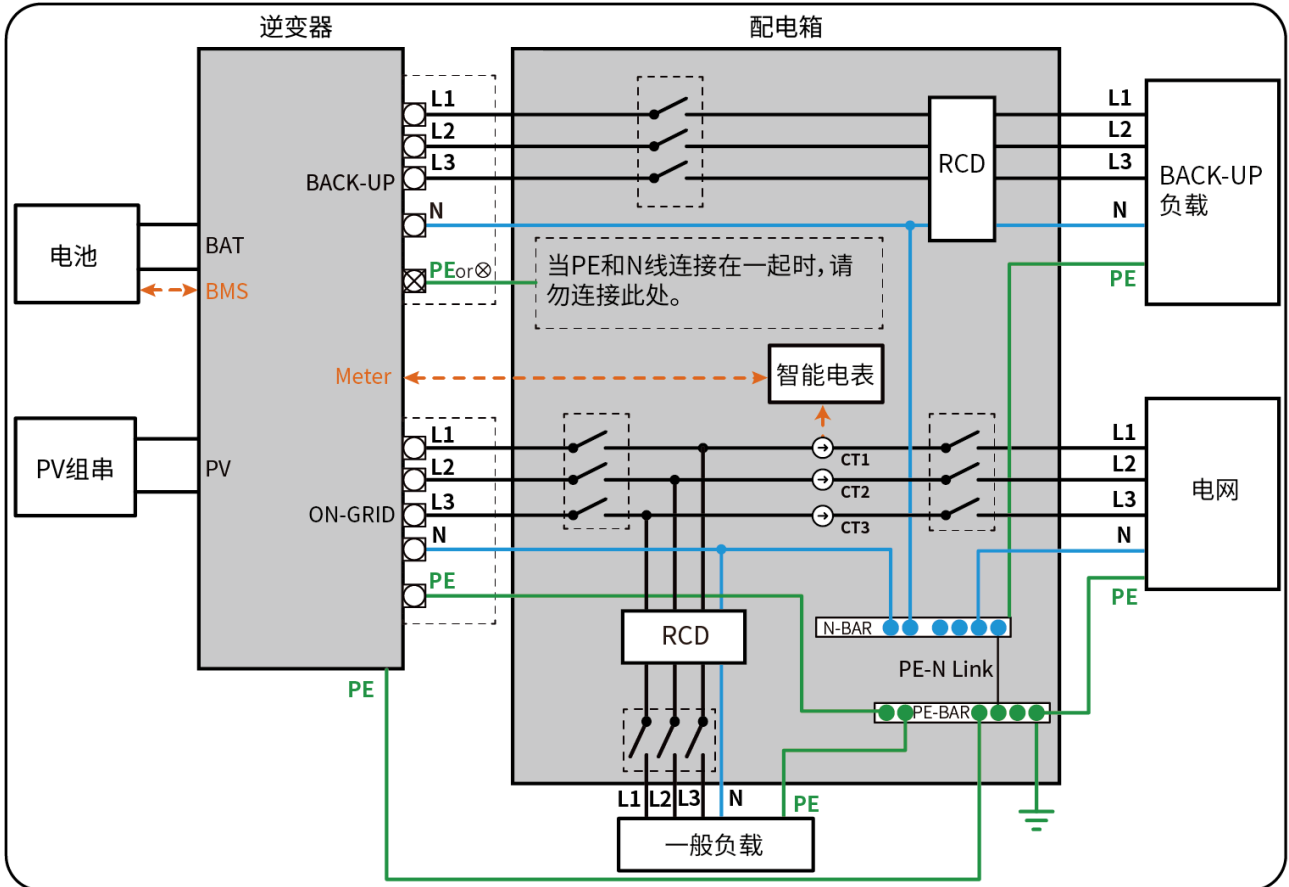

ET3010NET0015

**N and PE lines are separately wired in the distribution box**

**NOTICE**

- Ensure the protective grounding wire for the BACK-UP is correctly and securely connected; otherwise, the BACK-UP function may operate abnormally in the event of a grid fault.
- The following wiring method applies to regions other than Australia, New Zealand, etc.:

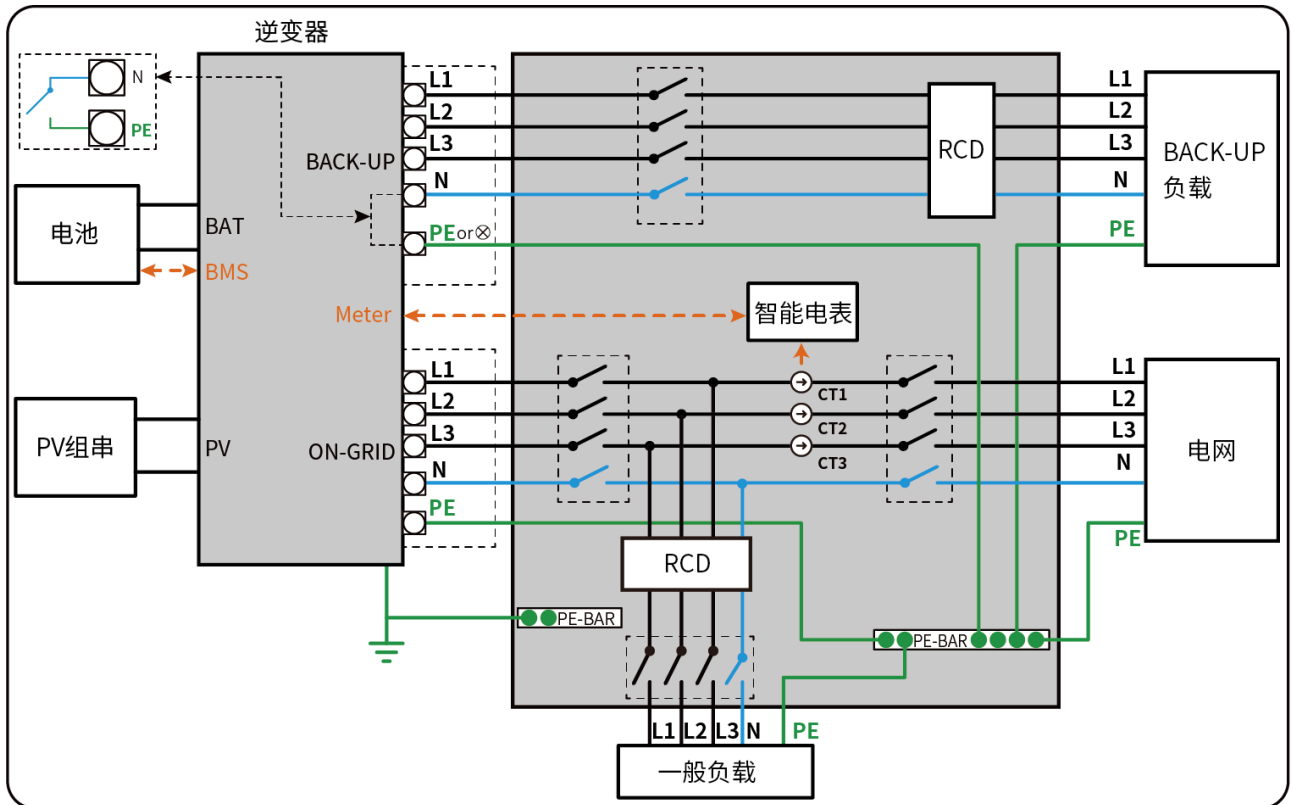

ET3010NET0016

## 5.2 Detailed System Wiring Diagram

When all loads in the photovoltaic system cannot consume the electricity generated by the system, the remaining electricity will feed into the grid. At this time, it can be paired with a smart meter or CT monitoring system to monitor the system's power generation and control the amount of electricity fed into the grid.

- Connecting a smart meter enables output power limiting and load monitoring functions.
- After connecting the smart meter, please enable the "Export power limit" function via the SolarGo App.

The Detailed System Wiring Diagram only shows wiring examples for some model devices. Please refer to the corresponding wiring guidance chapters based on the actual devices used for wiring.

## NOTICE

- In coupling scenarios, if grid-connected inverter power generation monitoring and load monitoring functions are required, dual meter networking must be used.
  - Meter 1 is used to monitor the system's grid-connected power.
  - Meter 2 is used to monitor the power generation of the grid-connected inverter.
  - By integrating the data from Meter 1 and Meter 2, the monitoring platform can achieve real-time monitoring of load power consumption.
- If the grid-connected inverter requires output power limitation, please connect a meter or CT device separately.

### Dual Meter Configuration Scenarios

Meter 1 (Grid Side)	Meter 2 (Grid-tied Inverter AC Side)
GM3000	GM3000
GM3000	GM330
GM3000	GMK330
GM330	GM330
GM330	GM3000
GM330	GMK330
GMK330	GMK330
GMK330	GM3000
GMK330	GM330

### Wiring diagram with protective cover (Australia only)

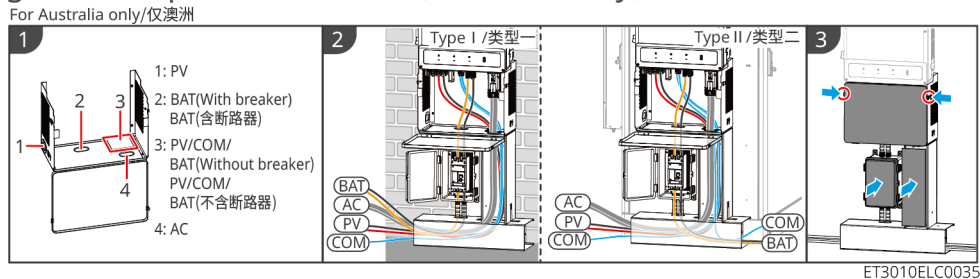

# 5.2.1 Detailed System Wiring Diagram for Single Inverter

## General Scenarios

For use with GM3000 scenario

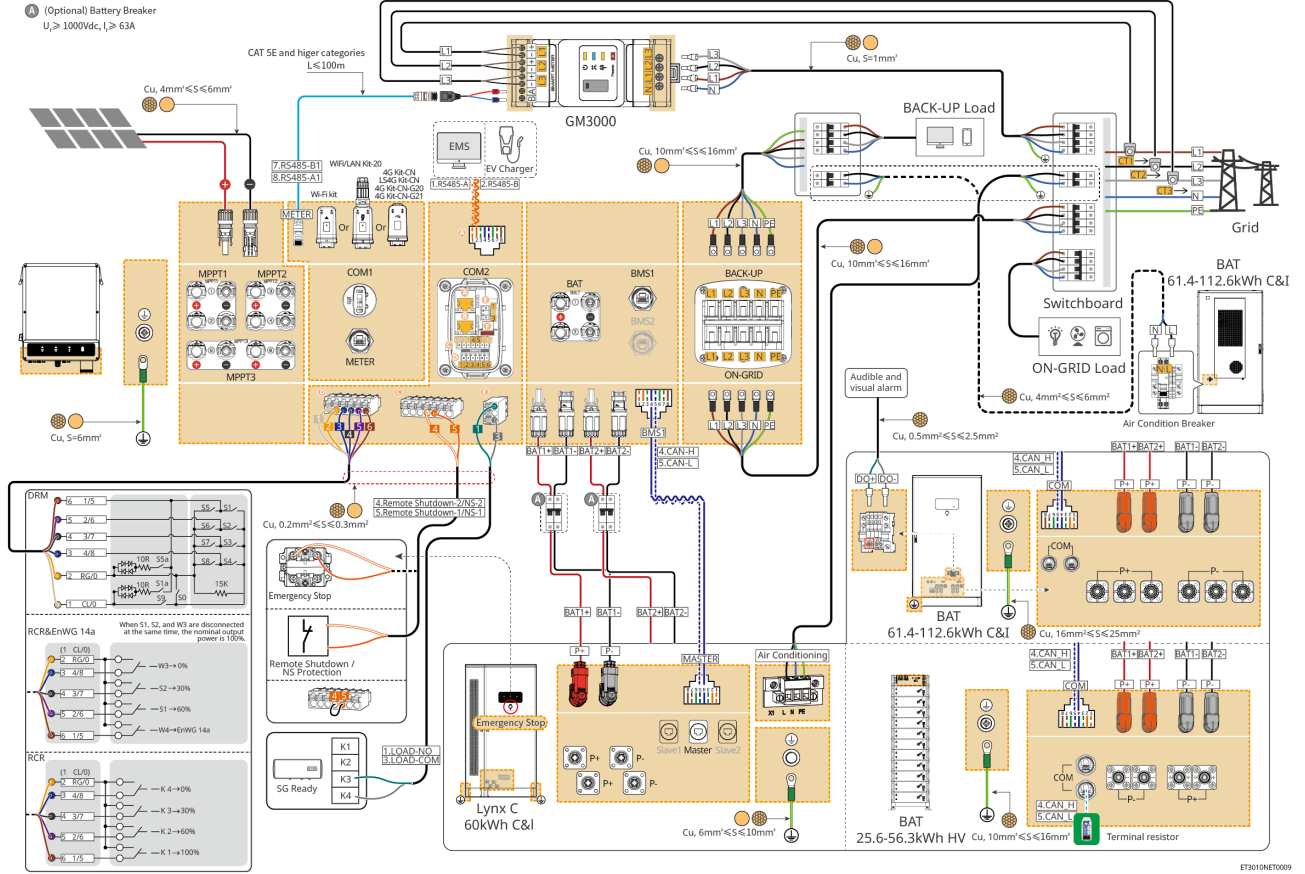

For use with GM330 scenario

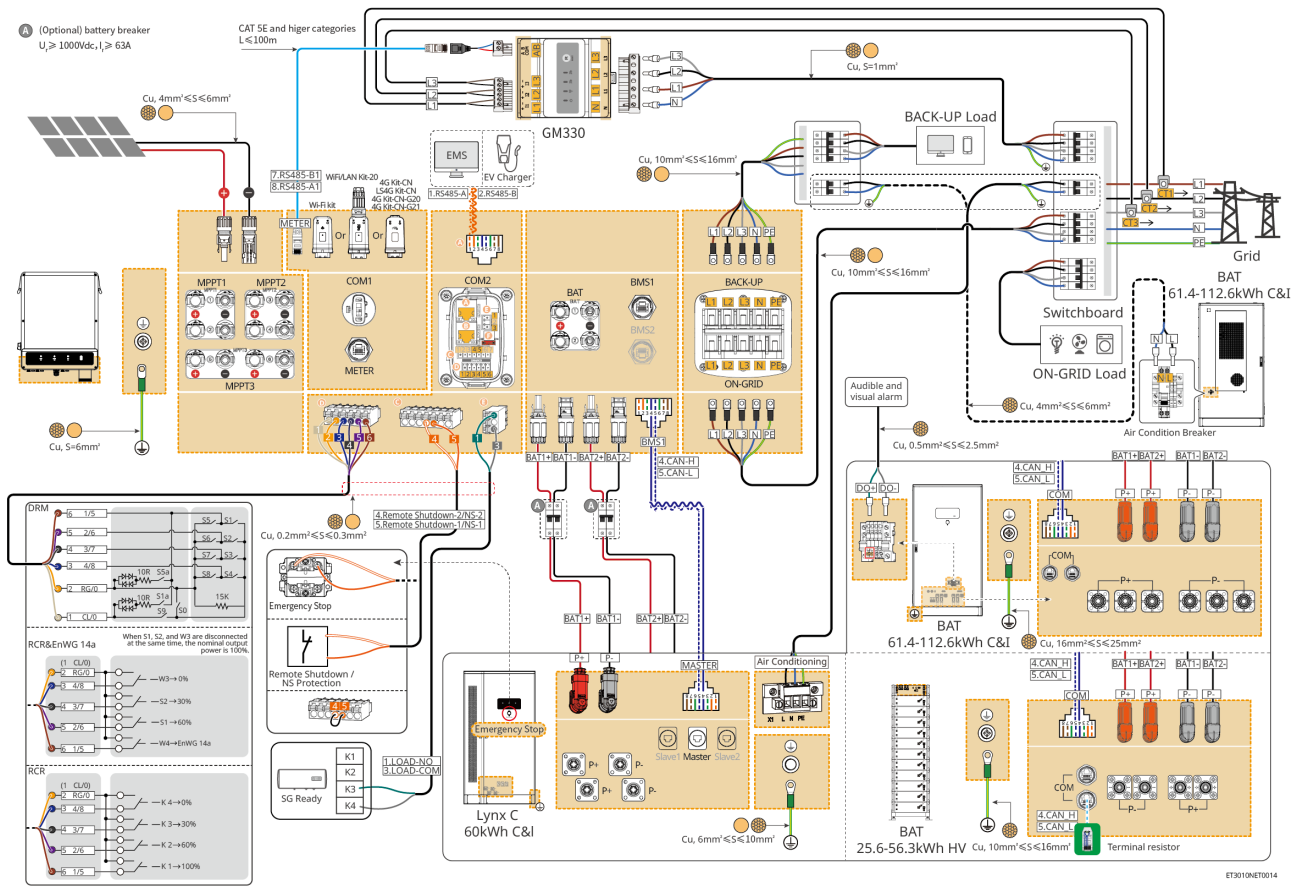

For use with GMK330 scenario



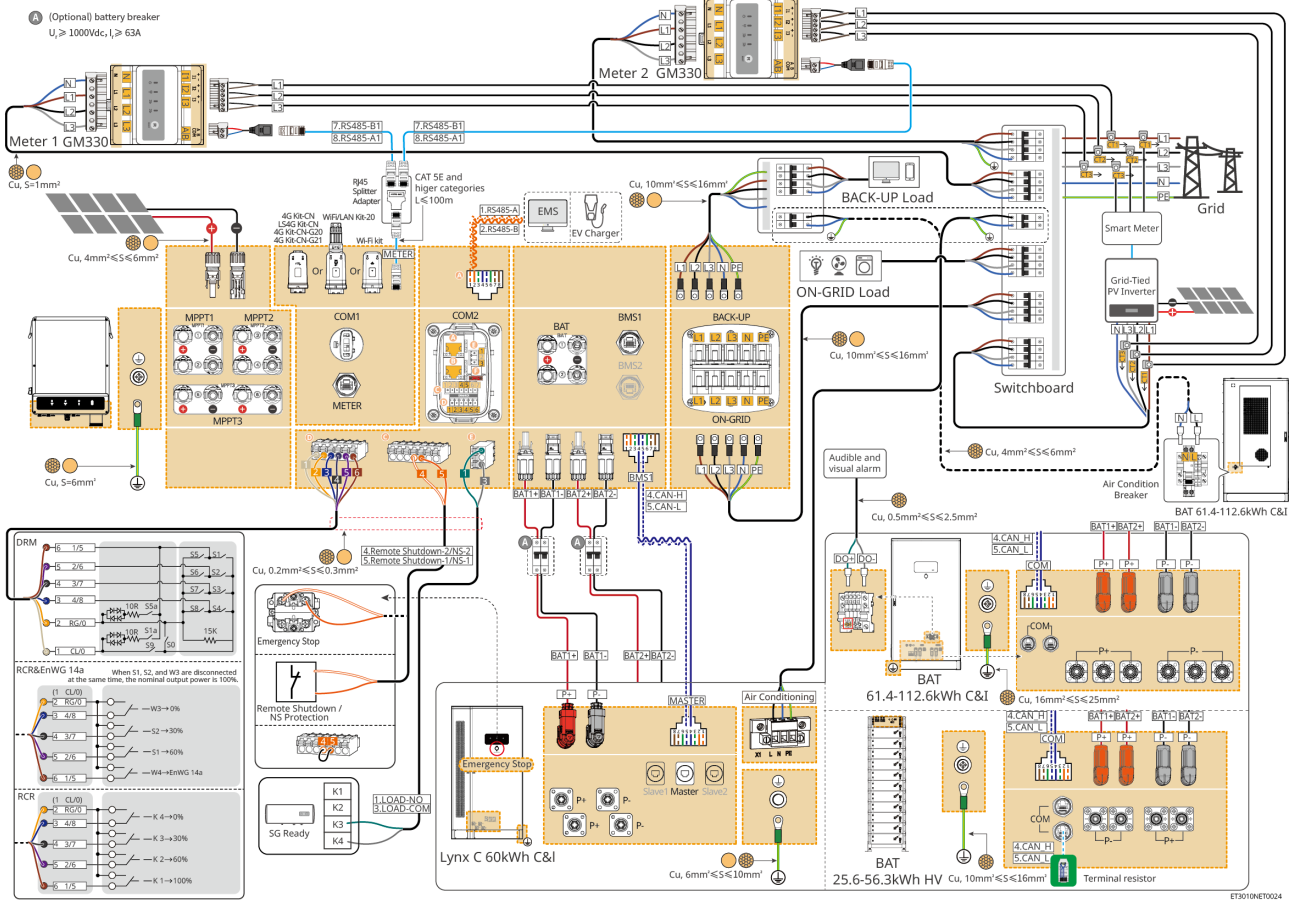

GMK330 meter + GMK330 meter

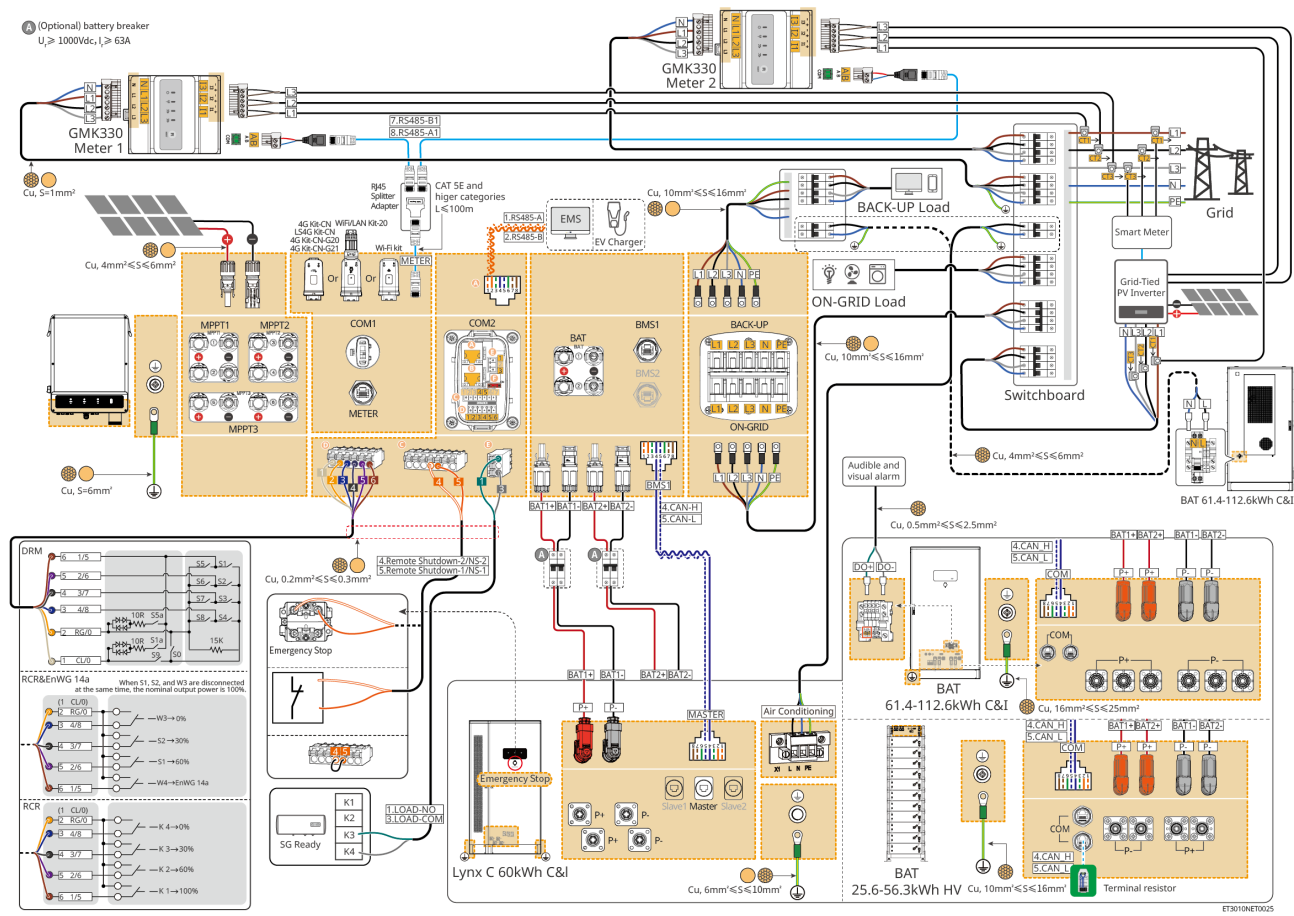

## 5.2.2 Detailed System Wiring Diagram for Parallel System

- In a parallel system scenario, the inverter connected to the Ezlink3000 smart communication stick and connected to the meter is the master inverter, while the others are slave inverters. Do not connect the smart communication stick to slave inverters in the system.
- If the system requires connection to devices such as DRED devices, RCR devices, remote shutdown devices, NS Protection, SG Ready heat pumps, etc., please connect them to the master inverter.
- The following diagrams focus on the wiring related to the parallel system. For wiring requirements of other ports, please refer to the single-unit system.

### WithGM3000 Scenario

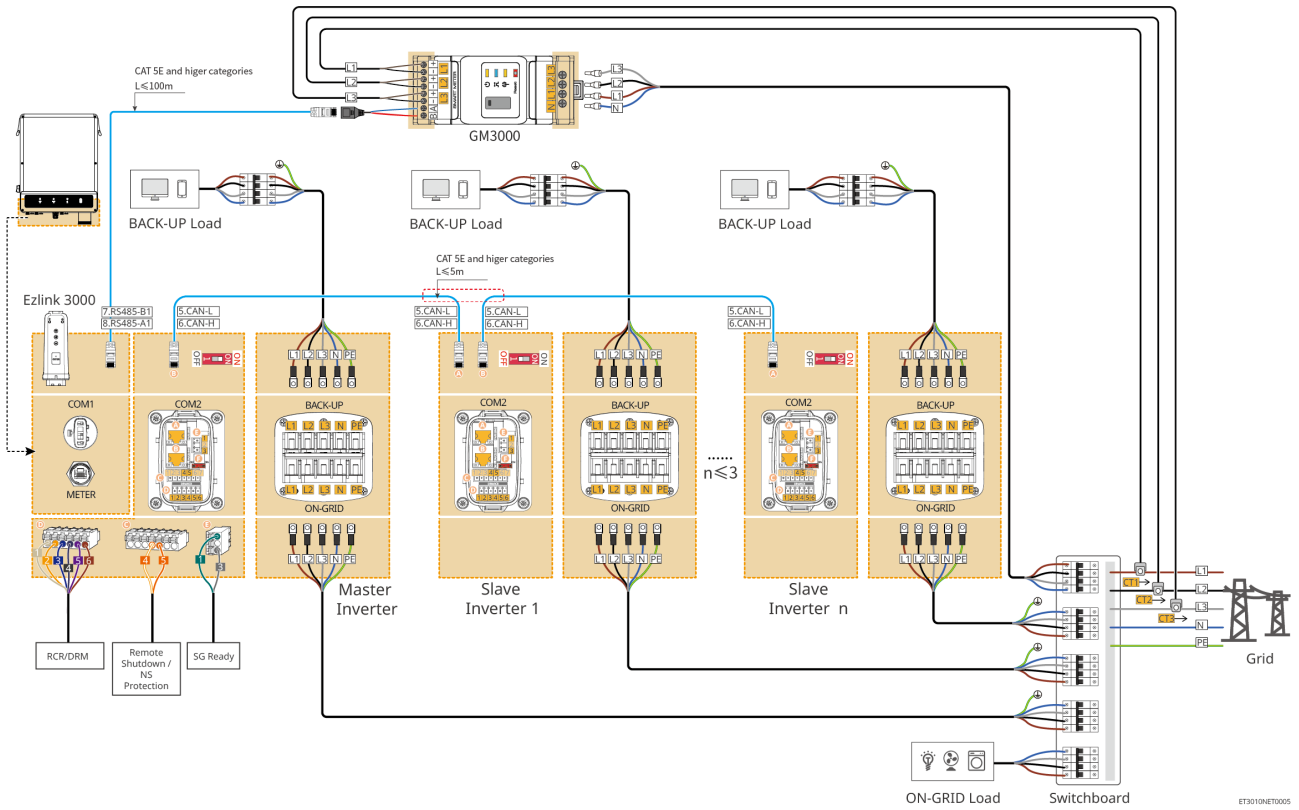

## With GM330 Scenario

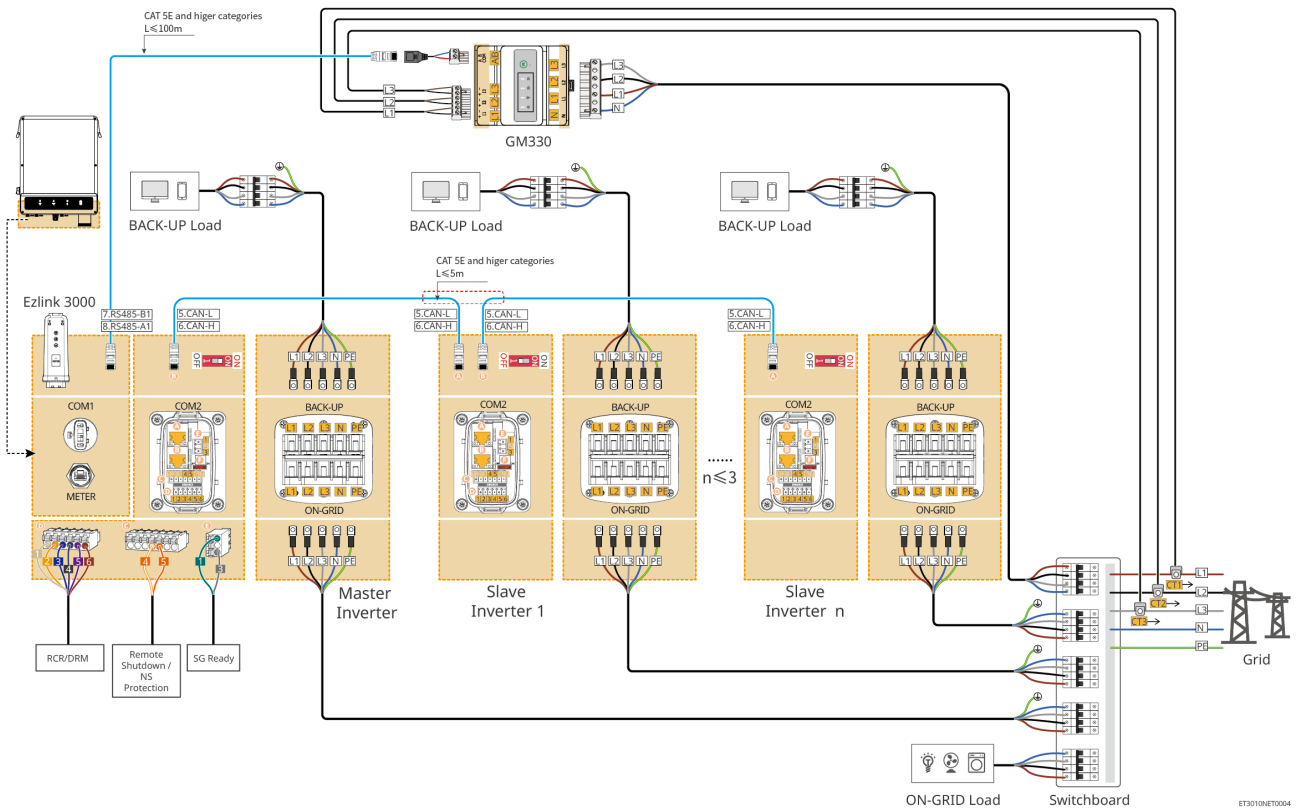

## With GMK330 Scenario

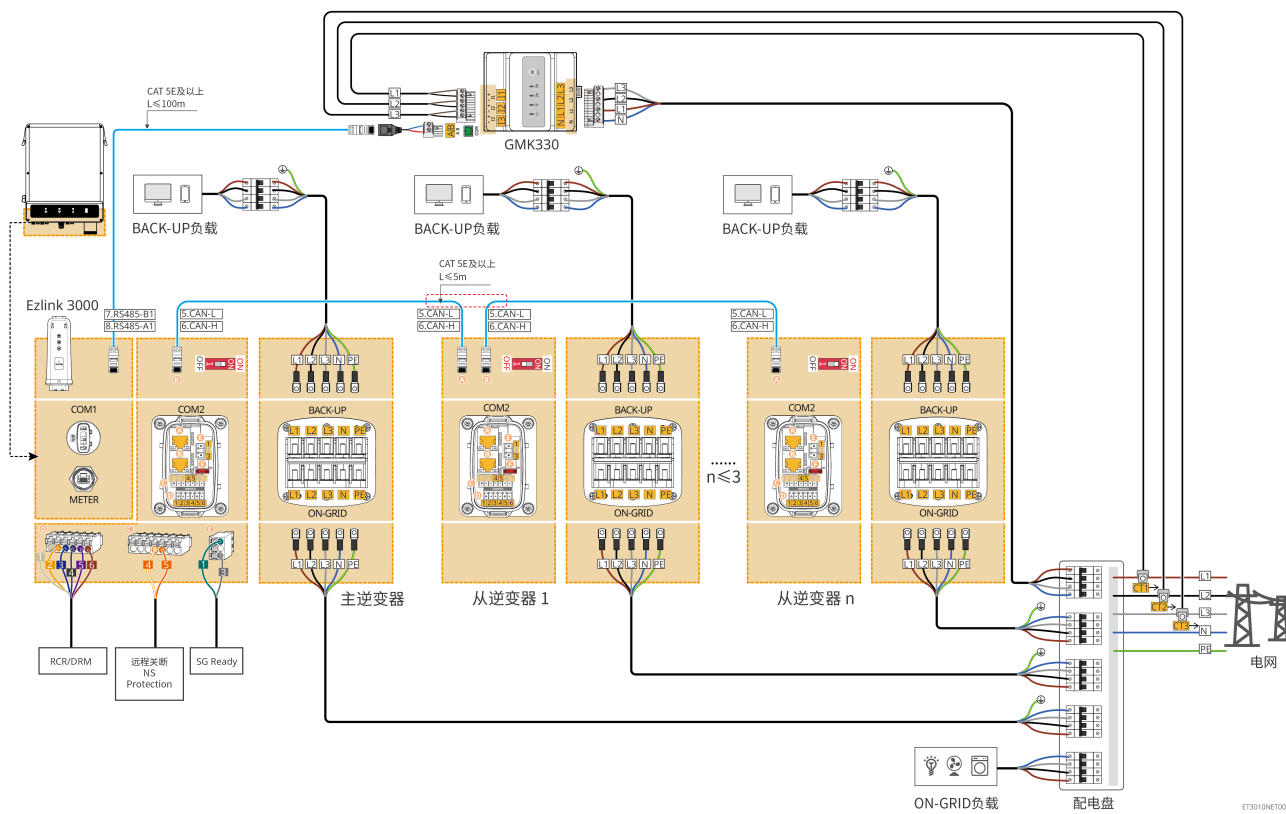

**Coupling Scenario Load Monitoring and Grid-Tie Inverter Power Generation Monitoring Networking Solution**  
 GMK330 Meter + GMK330 Meter

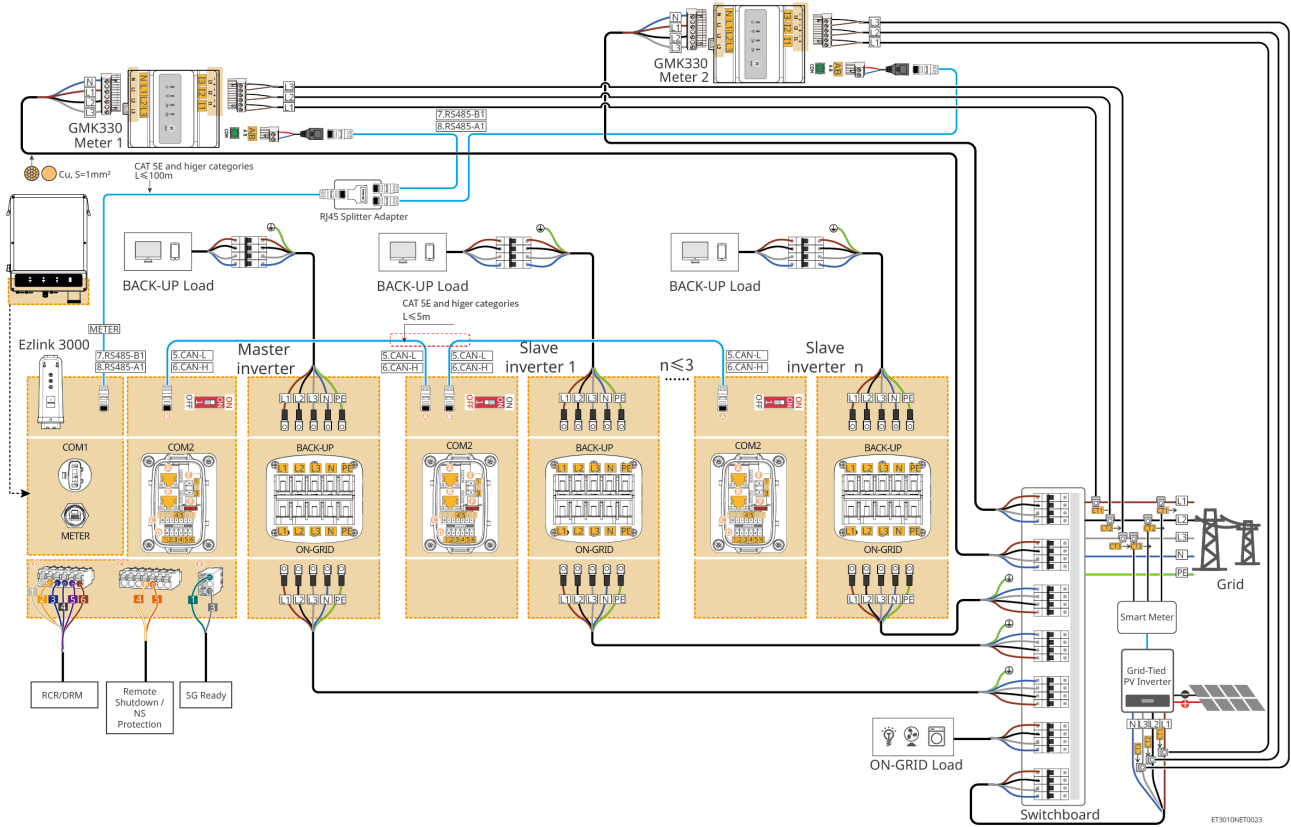

## 5.3 Preparing Materials

## WARNING

- Do not connect loads between the inverter and the AC switch directly connected to the inverter.
- Each inverter must be equipped with an AC output circuit breaker. Multiple inverters cannot be connected to one AC circuit breaker simultaneously.
- To ensure that the inverter can be safely disconnected from the grid in case of abnormalities, please connect an AC circuit breaker on the AC side of the inverter. Select a suitable AC circuit breaker according to local regulations.
- When the inverter is powered on, the BACK-UP AC port is live. If maintenance is required on the BACK-UP Loads, power off the inverter; otherwise, electric shock may occur.
- For cables used in the same system, it is recommended that the following be consistent: cable conductor material, cross-sectional area, length, etc.
  - BACK-UP AC cables for each inverter
  - ON-GRID AC cables for each inverter
  - Power cables between the inverter and the battery
  - Power cables between batteries
- The system only supports connecting a generator via an ATS switch in a single-unit scenario to achieve switching between grid and generator power supply. ATS switch is connected to the grid by default.

### 5.3.1 Preparing Breakers

No.	breaker	Recommended Specifications	Acquisition Method	Remarks
1	ON-GRID breaker	<p>When the BACK-UP port is not loaded, Nominal Voltage <math>\geq 400V</math>, Rated Current requirements are as follows:</p> <ul style="list-style-type: none"> <li>• GW15K-ET: Rated Current <math>\geq 32A</math></li> <li>• GW20K-ET: Rated Current <math>\geq 40A</math></li> <li>• GW25K-ET: Rated Current <math>\geq 50A</math></li> <li>• GW29.9K-ET, GW30K-ET: Rated Current <math>\geq 63A</math></li> </ul> <hr/> <p>When the BACK-UP port is loaded, Nominal Voltage <math>\geq 400V</math>, Rated Current requirements are as follows:</p> <ul style="list-style-type: none"> <li>• GW15K-ET: Rated Current <math>\geq 50A</math>;</li> <li>• GW20K-ET, GW25K-ET, GW29.9K-ET</li> <li>• GW30K-ET: Rated Current <math>\geq 63A</math></li> </ul>	Self-provided	If the inverter BACK-UP port is not used, an appropriate breaker can be selected based on the AC maximum output current.

No.	breaker	Recommended Specifications	Acquisition Method	Remarks
2	BACK-UP breaker	<p>Nominal Voltage <math>\geq 400V</math>, Rated Current requirements are as follows:</p> <ul style="list-style-type: none"> <li>• GW15K-ET: Rated Current <math>\geq 32A</math></li> <li>• GW20K-ET: Rated Current <math>\geq 40A</math></li> <li>• GW25K-ET: Rated Current <math>\geq 50A</math></li> <li>• GW29.9K-ET, GW30K-ET: Rated Current <math>\geq 63A</math></li> </ul>	Self-provide d	-
3	Battery switch	<p>Select according to local laws and regulations</p> <ul style="list-style-type: none"> <li>• 2P DC switch</li> <li>• Rated Current <math>\geq 63A</math></li> <li>• Nominal Voltage <math>\geq 1000V</math></li> </ul>	Self-provide d	-
4	RCD	<p>Select according to local laws and regulations</p> <ul style="list-style-type: none"> <li>• Type A</li> <li>• ON-GRID side: 300mA</li> <li>• BACK-UP side: 30mA</li> </ul>	Self-provide d	-
5	Meter switch	<ul style="list-style-type: none"> <li>• Nominal Voltage: 300V</li> <li>• Rated Current: 0.5A</li> </ul>	Self-provide d	-

### 5.3.2 Preparing Cables

No.	Cable	Recommended Specifications	Source
1	Inverter Protective Grounding Cable	<ul style="list-style-type: none"> <li>• Single-core outdoor copper cable</li> <li>• Conductor cross-sectional area: 6mm<sup>2</sup>-10mm<sup>2</sup></li> </ul>	Self-provided
2	Battery Protective Grounding Cable Lynx C Series 60kWh Commercial & Industrial Battery System	<ul style="list-style-type: none"> <li>• Single-core outdoor copper cable</li> <li>• Conductor cross-sectional area: 6mm<sup>2</sup></li> </ul>	Self-provided
	Battery Protective Grounding Cable BAT Series 25.6-56.3kWh High Voltage Battery	<ul style="list-style-type: none"> <li>• Single-core outdoor copper cable</li> <li>• Conductor cross-sectional area: 10-16mm<sup>2</sup></li> </ul>	
	Battery Protective Grounding Cable BAT Series 61.4-112.6kWh Commercial & Industrial Battery System	<ul style="list-style-type: none"> <li>• Single-core outdoor copper cable</li> <li>• Conductor cross-sectional area: 16-25mm<sup>2</sup></li> </ul>	
3	PV DC Cable	<ul style="list-style-type: none"> <li>• Industry-standard outdoor PV cable</li> <li>• Conductor cross-sectional area: 4mm<sup>2</sup>-6mm<sup>2</sup></li> <li>• Cable outer diameter: 5.9mm-8.8mm</li> </ul>	Self-provided

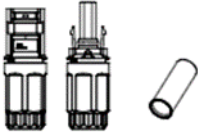
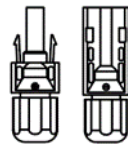
No.	Cable	Recommended Specifications	Source
4	Battery DC Cable	<p data-bbox="603 347 837 387">Terminal Type I</p>  <ul data-bbox="603 577 1141 801" style="list-style-type: none"> <li>• Single-core outdoor copper cable</li> <li>• Conductor cross-sectional area: 10mm<sup>2</sup></li> <li>• Cable outer diameter: 6.5mm-9.5mm</li> </ul> <hr data-bbox="603 828 1158 833"/> <p data-bbox="603 840 853 880">Terminal Type II</p>  <ul data-bbox="603 1081 1141 1305" style="list-style-type: none"> <li>• Single-core outdoor copper cable</li> <li>• Conductor cross-sectional area: 10mm<sup>2</sup></li> <li>• Cable outer diameter: 5mm-8.5mm</li> </ul>	Included with shipment/Self-provided
5	Battery Cluster Parallel Power Cable Lynx C Series 60kWh Commercial & Industrial Battery System	<ul data-bbox="603 1406 1141 1630" style="list-style-type: none"> <li>• Single-core outdoor copper cable</li> <li>• Conductor cross-sectional area: 32mm<sup>2</sup>-35mm<sup>2</sup></li> <li>• Cable outer diameter: 10mm-12mm</li> </ul>	Self-provided

No.	Cable	Recommended Specifications	Source
	Battery Cluster Parallel Power Cable BAT Series 25.6-56.3kWh High Voltage Battery	<ul style="list-style-type: none"> <li>• Single-core outdoor copper cable</li> <li>• Conductor cross-sectional area: 25mm<sup>2</sup></li> <li>• Cable outer diameter: 9mm-11mm</li> </ul>	Self-provided
6	AC Cable	<ul style="list-style-type: none"> <li>• Multi-core outdoor copper cable</li> <li>• Conductor cross-sectional area: 10mm<sup>2</sup>-16mm<sup>2</sup></li> <li>• Cable outer diameter: 21mm-26mm</li> </ul>	Self-provided
7	Smart Meter Power Cable	Outdoor copper cable Conductor cross-sectional area: 1mm <sup>2</sup>	Self-provided
8	Battery BMS Communication cable	-	Included with shipment
9	Meter RS485 Communication cable	-	RJ45-2PIN terminal adapter cable and standard Ethernet cable, included with shipment
10	Battery Cluster Parallel Communication cable	CAT 5E or higher standard Ethernet cable and RJ45 connector	Self-provided
11	load control DO Communication cable	<ul style="list-style-type: none"> <li>• Shielded cable meeting local standards</li> <li>• Conductor cross-sectional area: 0.2mm<sup>2</sup>-0.3mm<sup>2</sup></li> <li>• Cable outer diameter: 5mm-8mm</li> </ul>	Self-provided
12	Remote Shutdown Communication cable		Self-provided
13	RCR/DRED Signal Cable		Self-provided

No.	Cable	Recommended Specifications	Source
14	Inverter Parallel Communication Cable	CAT 5E or higher standard Ethernet cable and RJ45 connector	Self-provided
15	EMS Communication cable/EV Charger Communication Cable	CAT 5E or higher standard Ethernet cable and RJ45 connector	Self-provided
16	12V External Power Supply Cable	<ul style="list-style-type: none"> <li>• Outdoor copper cable</li> <li>• Conductor cross-sectional area: 0.2mm<sup>2</sup>-0.3mm<sup>2</sup></li> <li>• Cable outer diameter: 5mm-8mm</li> </ul>	Self-provided
17	Air Conditioner Power Cable Lynx C Series 60kWh Commercial & Industrial Battery System	-	Pre-installed
	Air Conditioner Power Cable BAT Series 61.4-112.6kWh Commercial & Industrial Battery System	-	Included with shipment

### 5.3.3 Remove the Baffle

#### WARNING

- After system installation is complete, before starting wiring, please remove the baffle.
- After system wiring is complete, please install the baffle to the enclosure.

Remove the bottom baffle

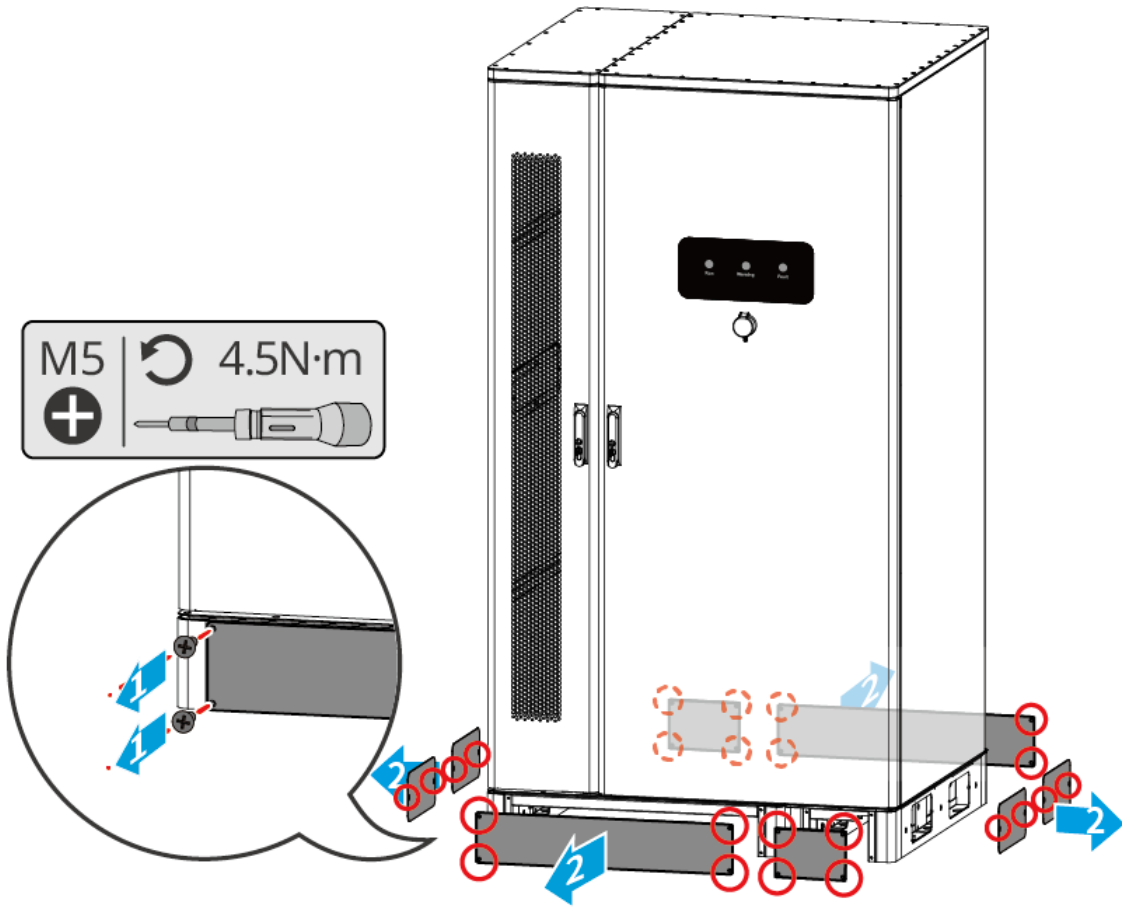

LXC6010INT0011

Inverter wiring area baffle

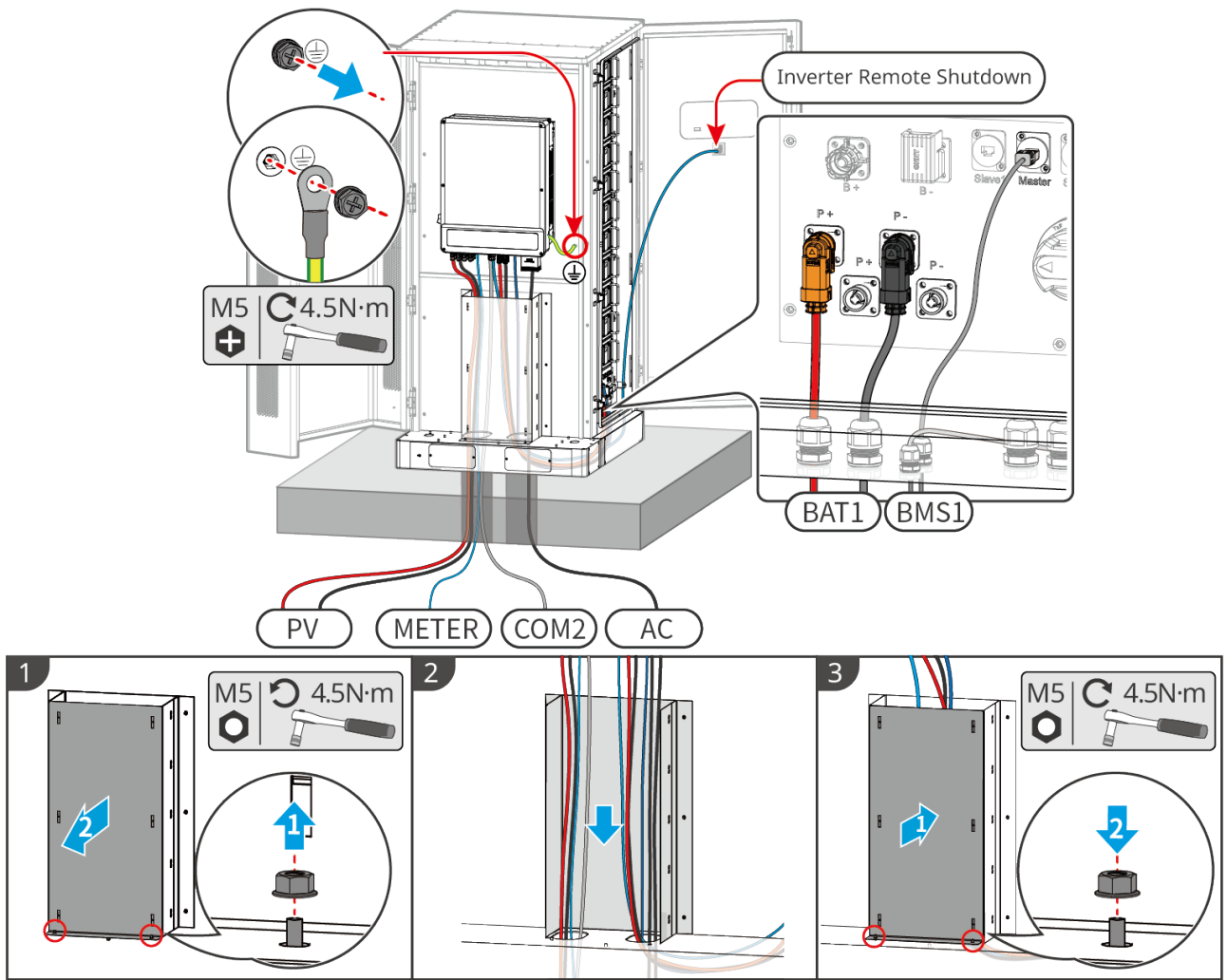

LXC6010ELC0004

## 5.4 Connecting the PE cable

## !WARNING

- The protective grounding of the chassis cannot replace the protective ground wire of the AC output port. When wiring, ensure the protective ground wires at both locations are securely connected.
- To improve the corrosion resistance of the terminal, it is recommended to apply silicone or paint over the external part of the grounding terminal for protection after the protective ground wire installation is complete.
- When installing the equipment, the protective ground wire must be installed first. When removing the equipment, the protective ground wire must be removed last.

### 5.4.1 Inverter Grounding

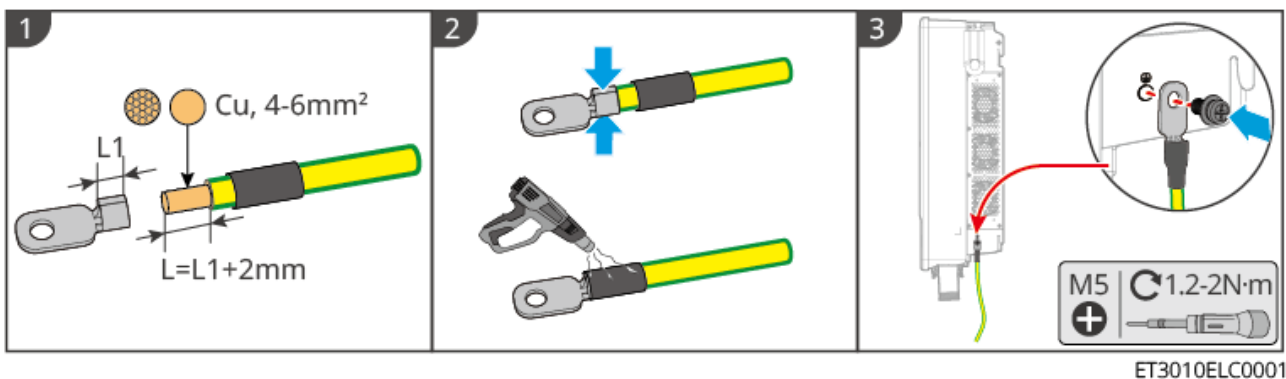

### 5.4.2 Battery System Grounding

- Lynx C Series 60kWh Commercial and Industrial Battery System

Type One

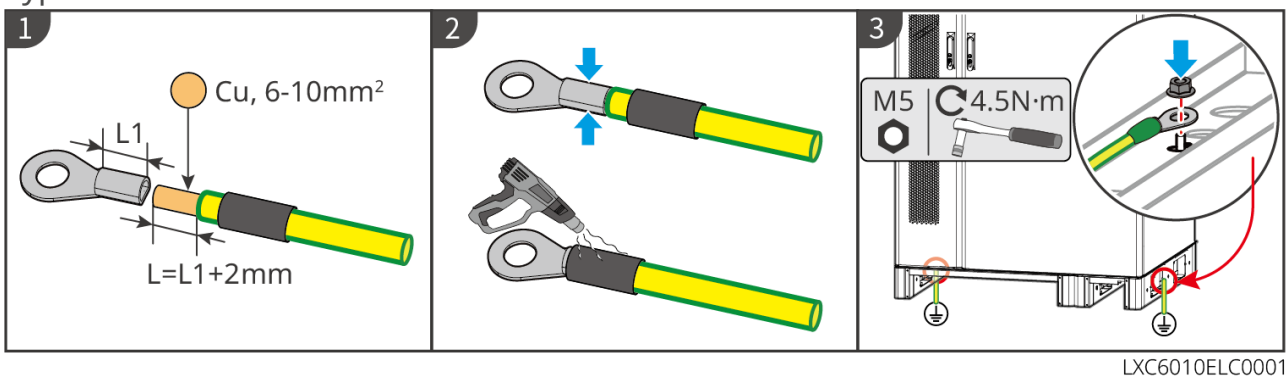

## Type Two

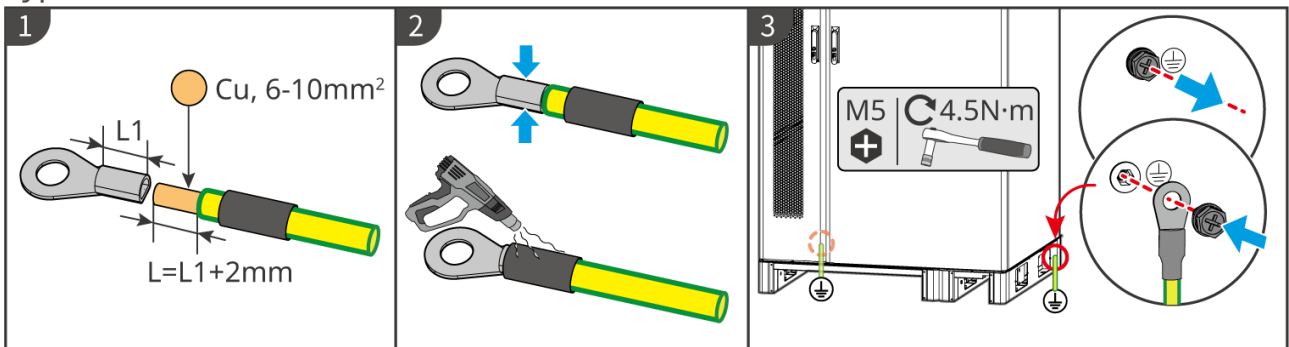

LXC6010ELC0007

## • BATSeries 25.6-56.3kWh High Voltage Battery

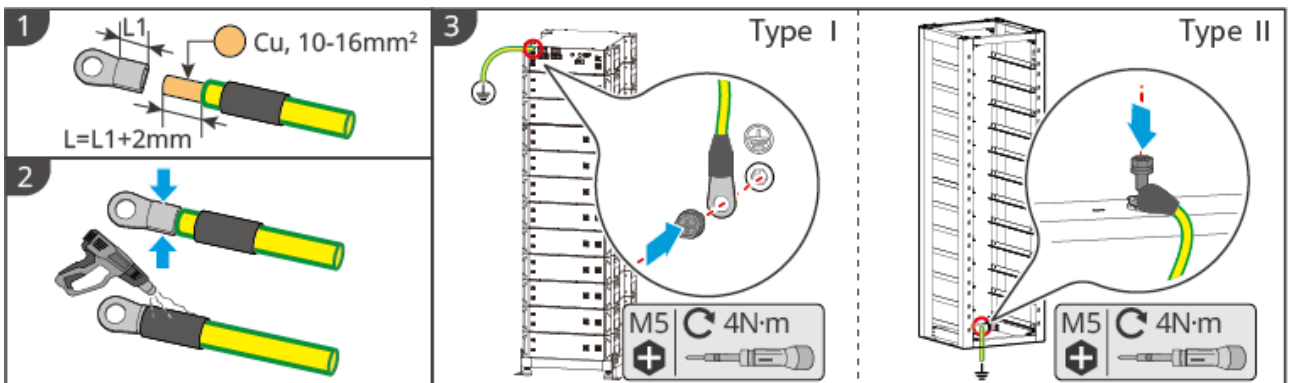

BAT10ELC0001

## • BATSeries 61.4-112.6kWh Commercial and Industrial Battery System

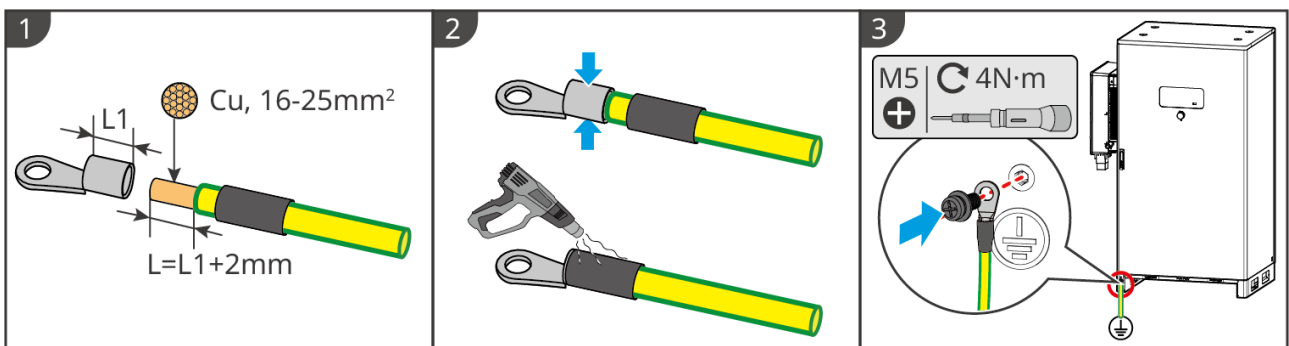

BAT10ELC0007

## 5.5 Connecting the PV Cable

## DANGER

- Do not connect the same PV string to multiple inverters, otherwise it may cause inverter damage.
- Before connecting the PV string to the inverter, please confirm the following information, otherwise it may cause permanent damage to the inverter, and in severe cases, it may lead to fire causing personal and property losses.
  1. Ensure that the maximum short-circuit current and maximum input voltage of each MPPT are within the allowable range of the inverter.
  2. Ensure that the positive pole of the PV string is connected to the PV+ of the inverter, and the negative pole of the PV string is connected to the PV- of the inverter.

## WARNING

- PV string output does not support grounding. Before connecting the PV string to the inverter, ensure that the minimum insulation resistance to ground of the PV string meets the minimum insulation impedance requirement ( $R = \text{Max. Input Voltage} / 30\text{mA}$ ).
- After completing the DC cable connection, ensure that the cable connections are tight and not loose.
- Use a multimeter to measure the positive and negative poles of the DC cable to ensure that the polarity is correct and there is no reverse connection; and the voltage is within the allowable range.

## NOTICE

The two PV strings within each MPPT circuit must use identical models, have the same number of panels, and maintain the same tilt and azimuth angles to ensure maximum efficiency.

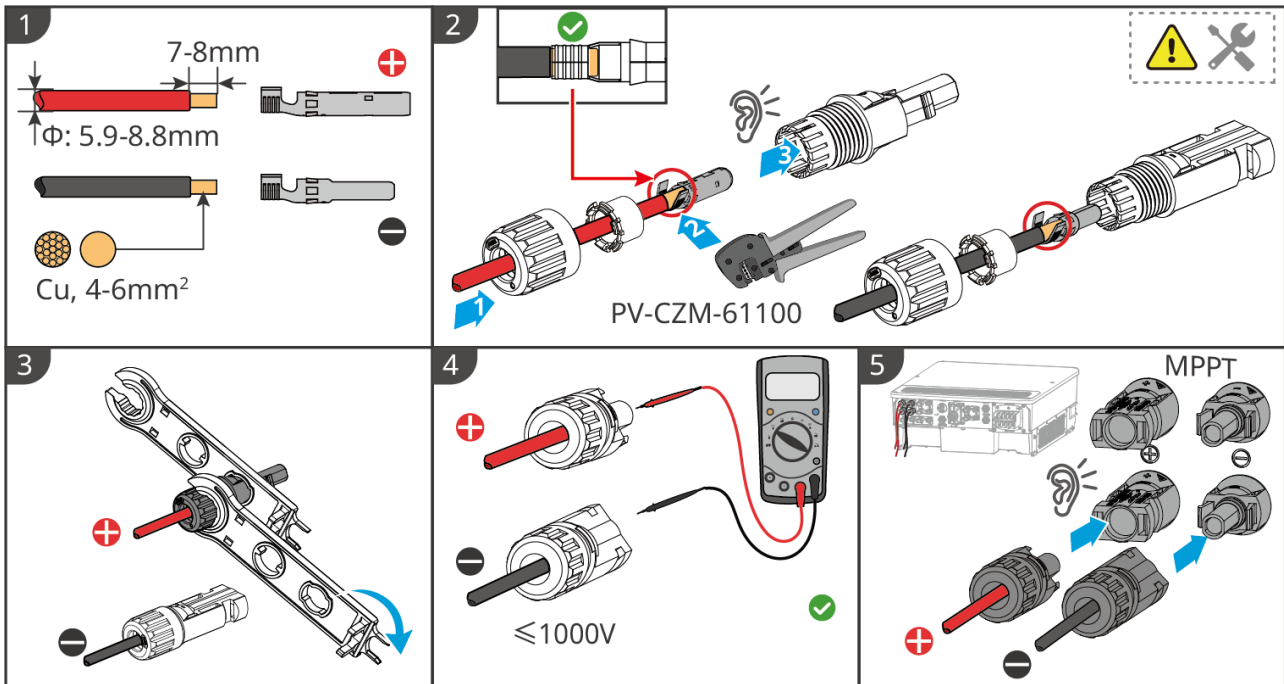

ET3010ELC0030

## 5.6 Connecting Battery System Cables

### DANGER

- Do not connect the same battery pack to multiple inverters, as this may cause inverter damage.
- It is prohibited to connect loads between the inverter and the battery.
- When connecting battery cables, use insulated tools to prevent accidental electric shock or battery short circuit.
- Ensure that the battery open-circuit voltage is within the allowable range of the inverter.
- Before connecting battery cables, confirm that the battery module and high-voltage box are powered off, and the battery cluster switch and DC power supply switch are disconnected.
- Between the inverter and the battery, choose whether to configure a DC switch according to local laws and regulations.

## WARNING

- Use a multimeter to measure the positive and negative terminals of the DC cable to ensure correct polarity, with no reverse connection, and that the voltage is within the allowable range.
- During wiring, ensure the battery cables match the "BAT+", "BAT-", and grounding ports on the battery terminals completely. Incorrect cable connection will cause equipment damage.
- Ensure the wire cores are fully inserted into the terminal connection holes with no exposed parts.
- Ensure the cable connections are tight, otherwise, loose connections may cause terminal overheating and equipment damage during operation.
- Do not connect the same battery bank to multiple inverters, as this may cause inverter damage.

## NOTICE

When a 25-30kW inverter is used with the BAT series 61.4kWh commercial and industrial battery system, it is necessary to connect two BAT ports to achieve full load operation.

### Battery System Wiring Diagram

- Lynx C Series 60kWh Commercial & Industrial Battery System

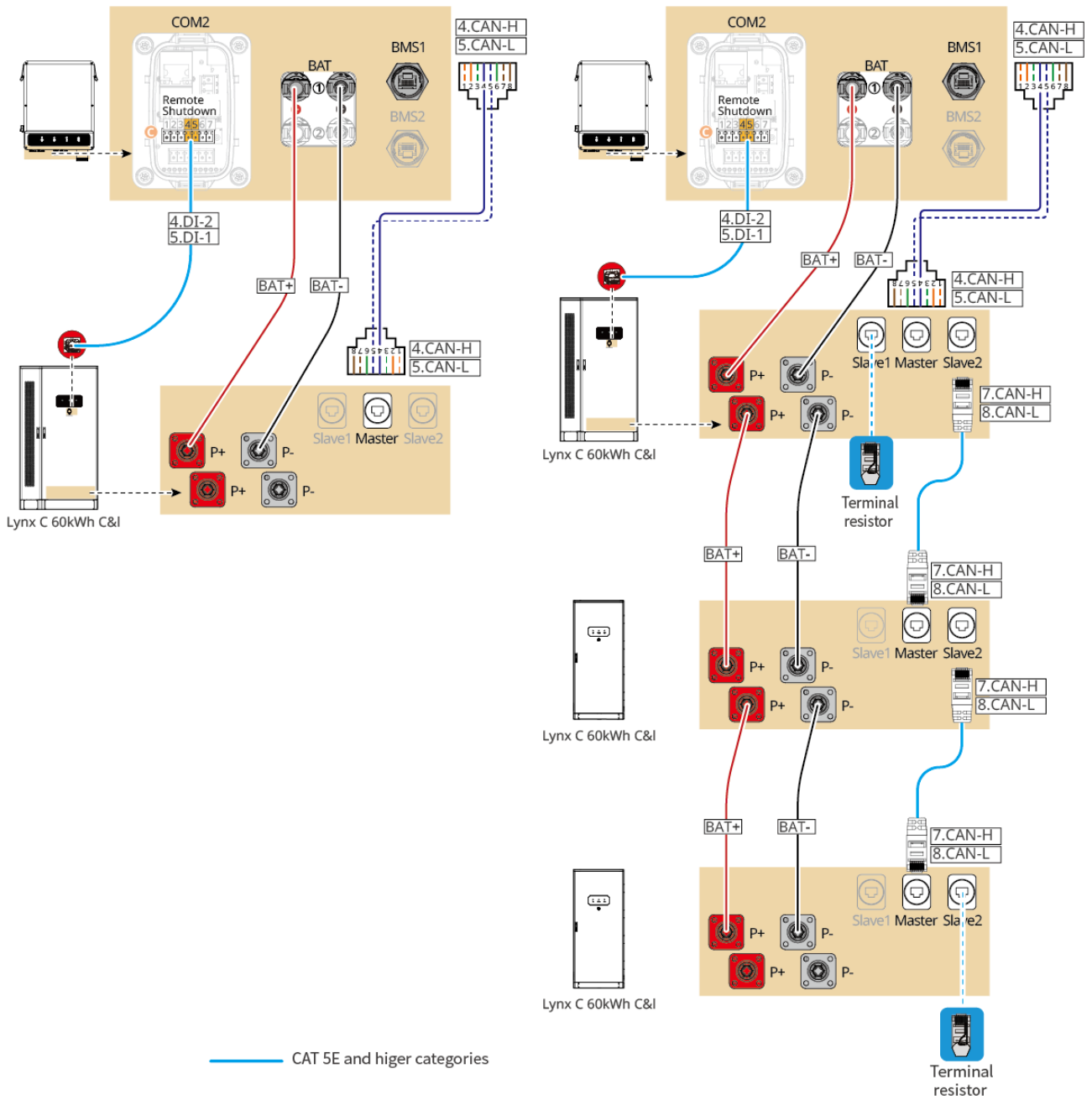

ET3010NET0026

- BAT-S Series 25.6-56.3kWh High Voltage Battery

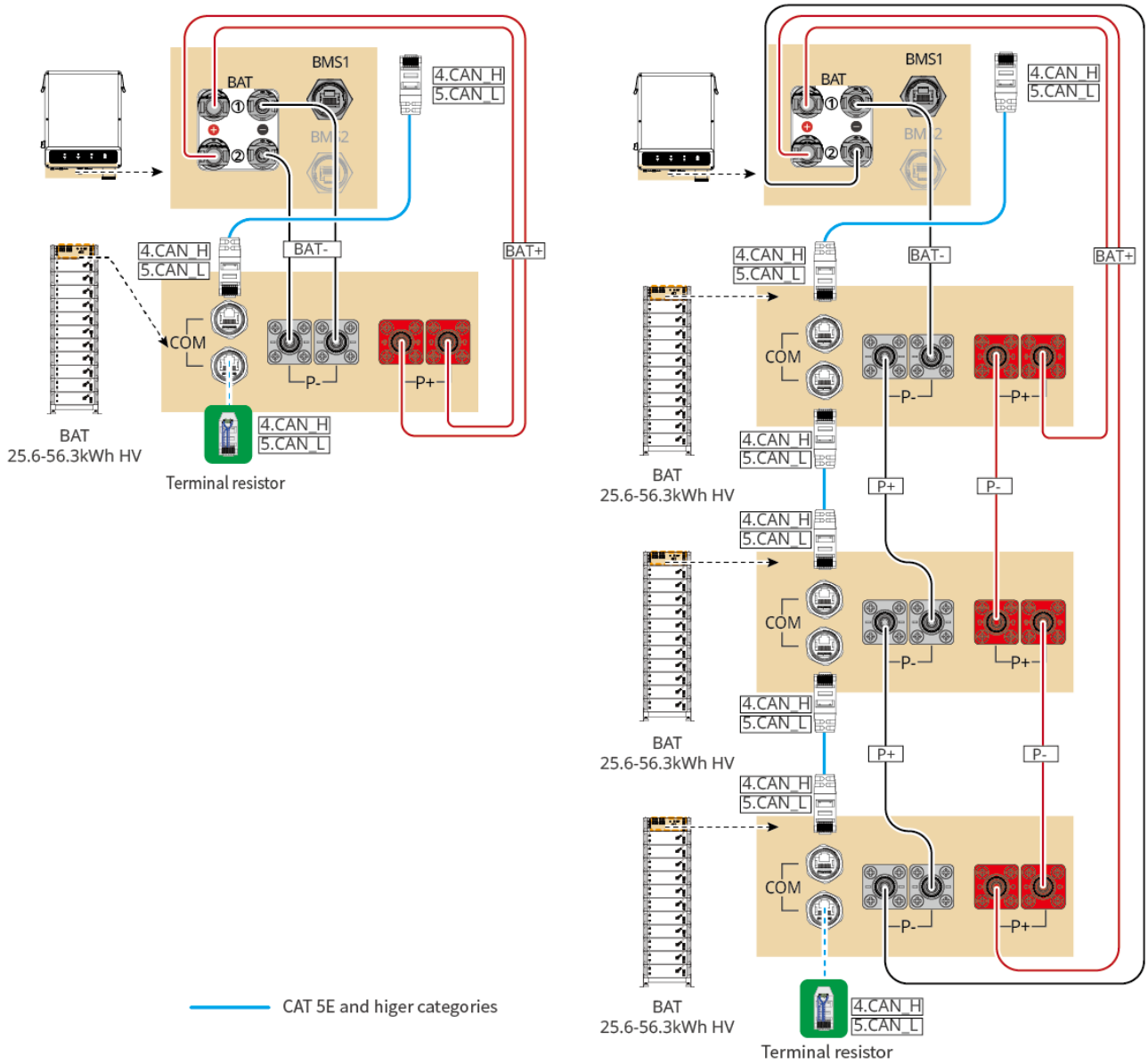

ET3010NET0027

- BAT-C Series 61.4-112.6kWh Commercial & Industrial Battery System

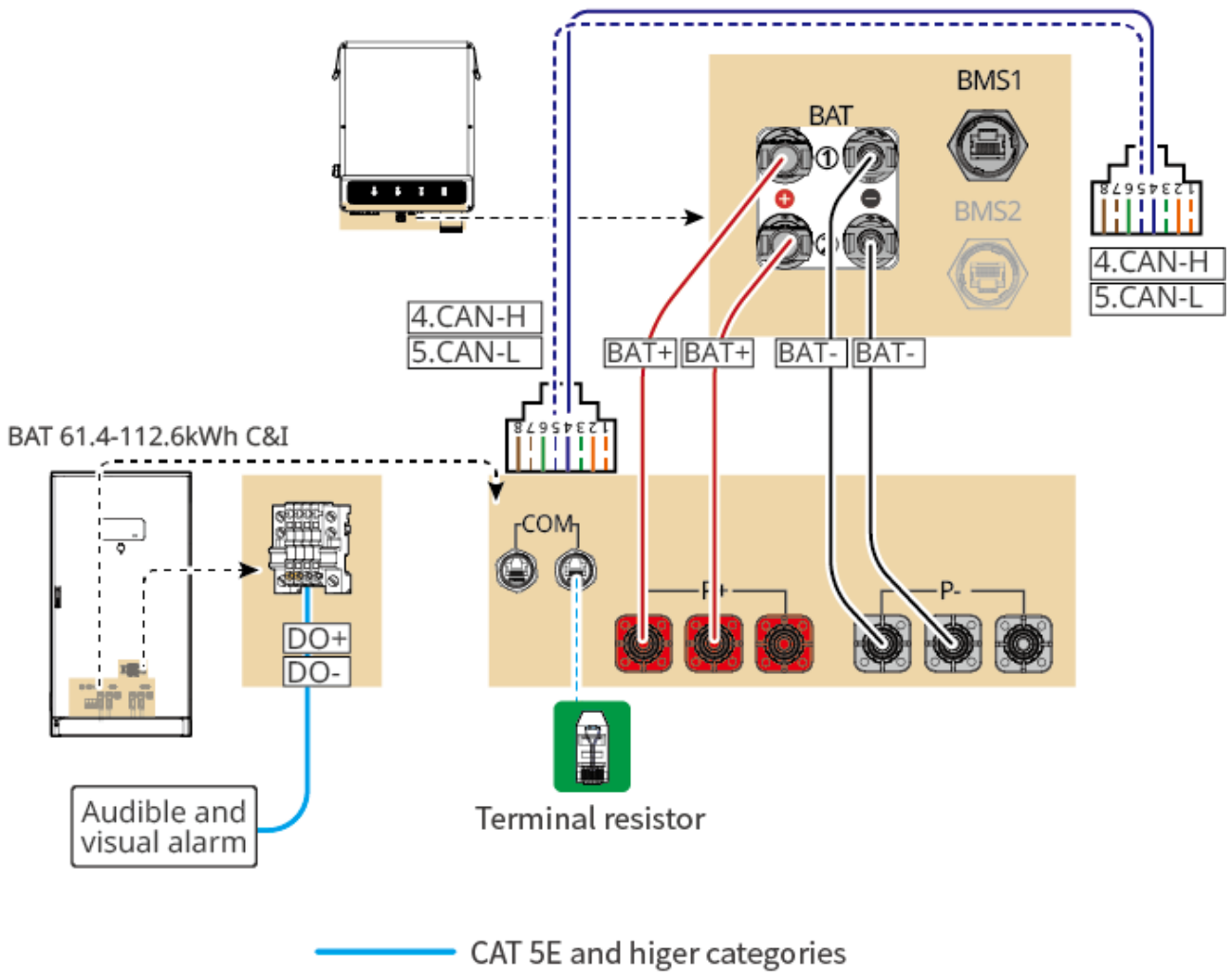

ET3010NET0012

## 5.6.1 Paired with Lynx C Series 60kWh Commercial and Industrial Battery System

### 5.6.1.1 Introduction to Battery Wiring Holes

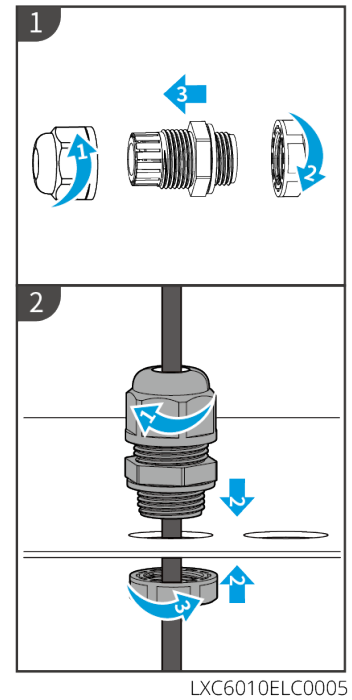
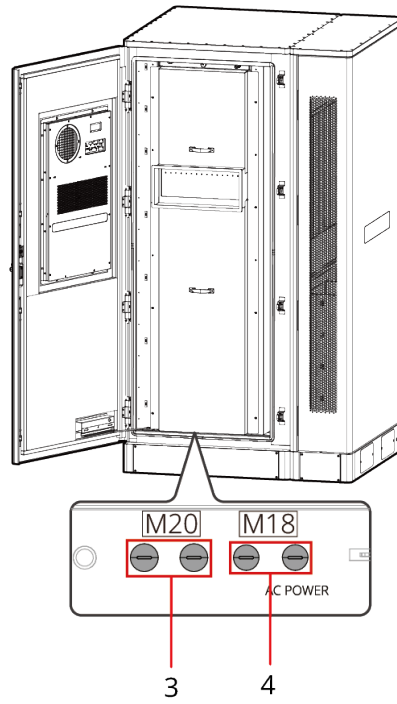
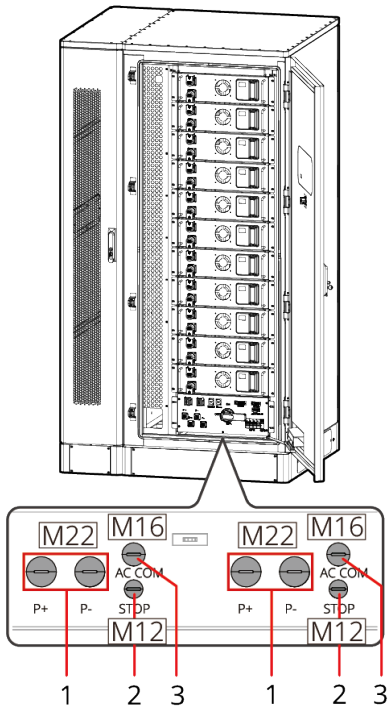

LXC6010ELC0005

No.	Description	No.	Description
1	Battery power cable pass-through hole	2	Emergency stop button control cable pass-through hole
3	Communication cable pass-through hole	4	Air conditioning cable pass-through hole
5	Reserved pass-through hole	-	-

### 5.6.1.2 Connecting the Power Cable between the Inverter and Battery

## WARNING

- Use a multimeter to measure the DC cable's positive and negative poles to ensure correct polarity, with no reverse connection, and that the voltage is within the allowable range.
- During wiring, ensure the battery cables match the battery terminals "BAT+", "BAT-", and ground port completely. Incorrect cable connection will cause equipment damage.
- Ensure the wire core is fully inserted into the terminal's wiring hole with no exposure.
- Ensure the cable connections are tight. Otherwise, during equipment operation, the terminals may overheat and cause equipment damage.
- Do not connect the same battery bank to multiple inverters, as this may cause inverter damage.

## NOTICE

- The battery system comes with power cables for connecting to the inverter.
  - If the inverter accessories include a Type I terminal, cut off the terminal on the battery power cable that connects to the inverter, and use the battery connector provided with the inverter to remake the power cable.
  - If the inverter accessories include a Type II terminal, you can directly use the power cable from the battery accessories.
  - If the power cable in the battery accessories does not have a terminal for connecting to the inverter, use the connector from the inverter accessories to make the power cable.
- Power cables for parallel clustering between battery systems need to be self-provided.
- Please connect the battery system to the inverter's BAT1 port.

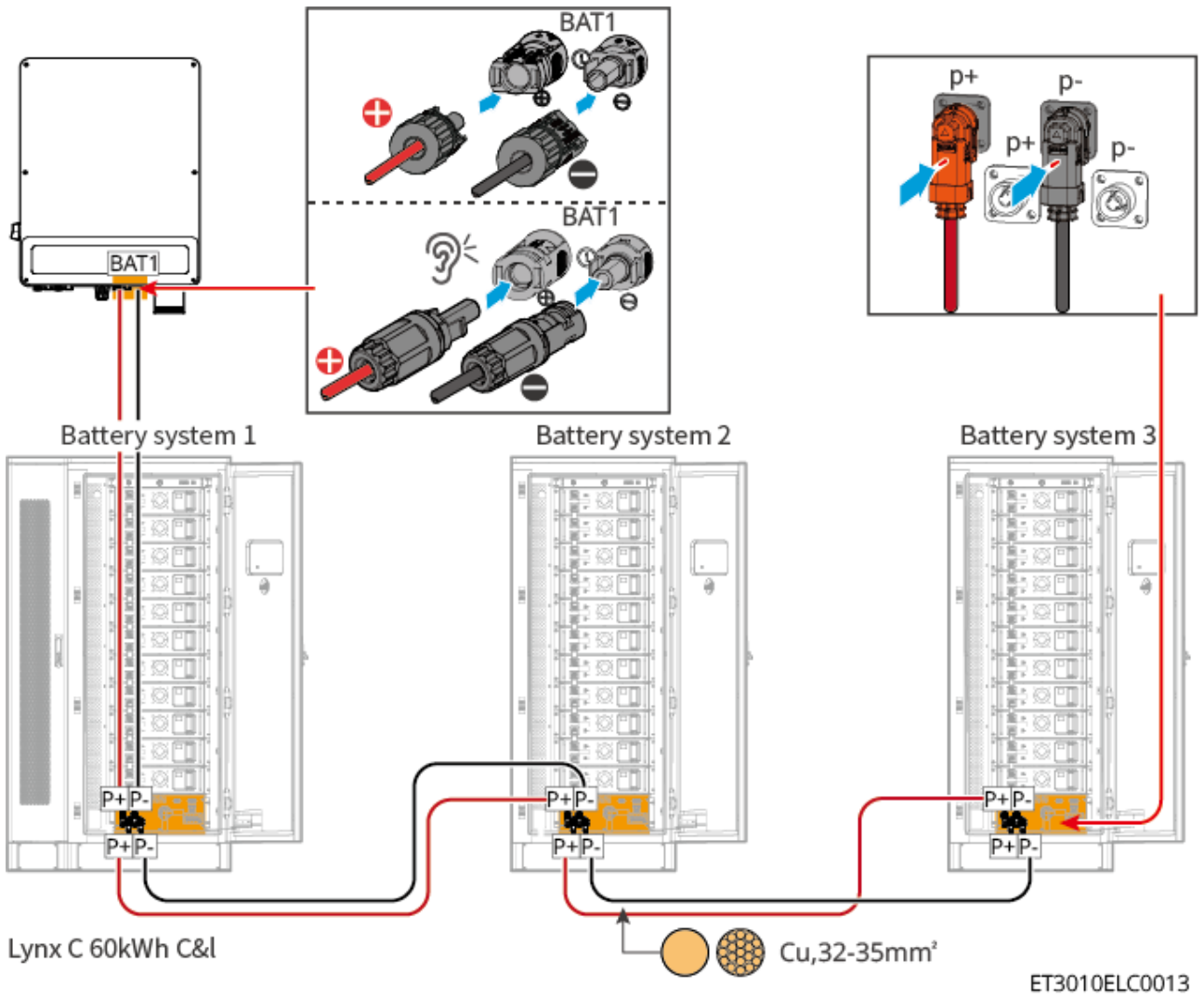

**Inverter End Cable Preparation Method**

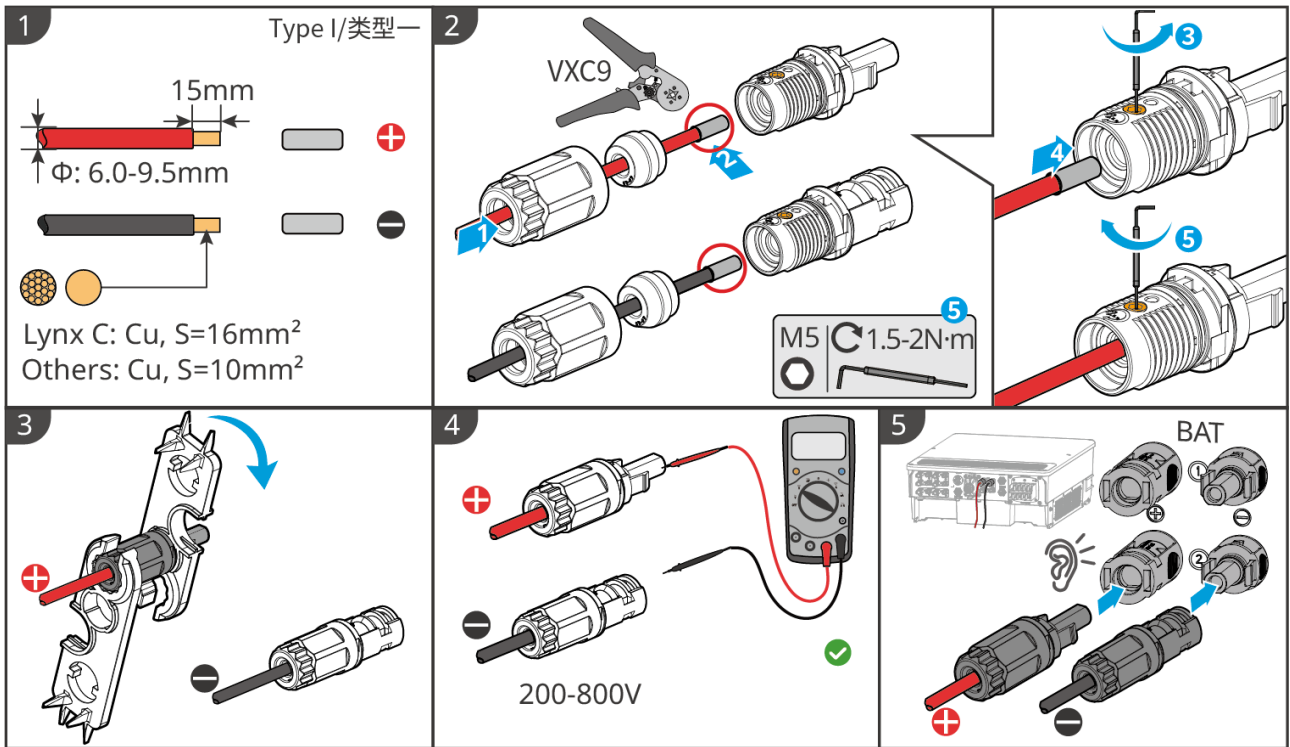

ET3010ELC0031

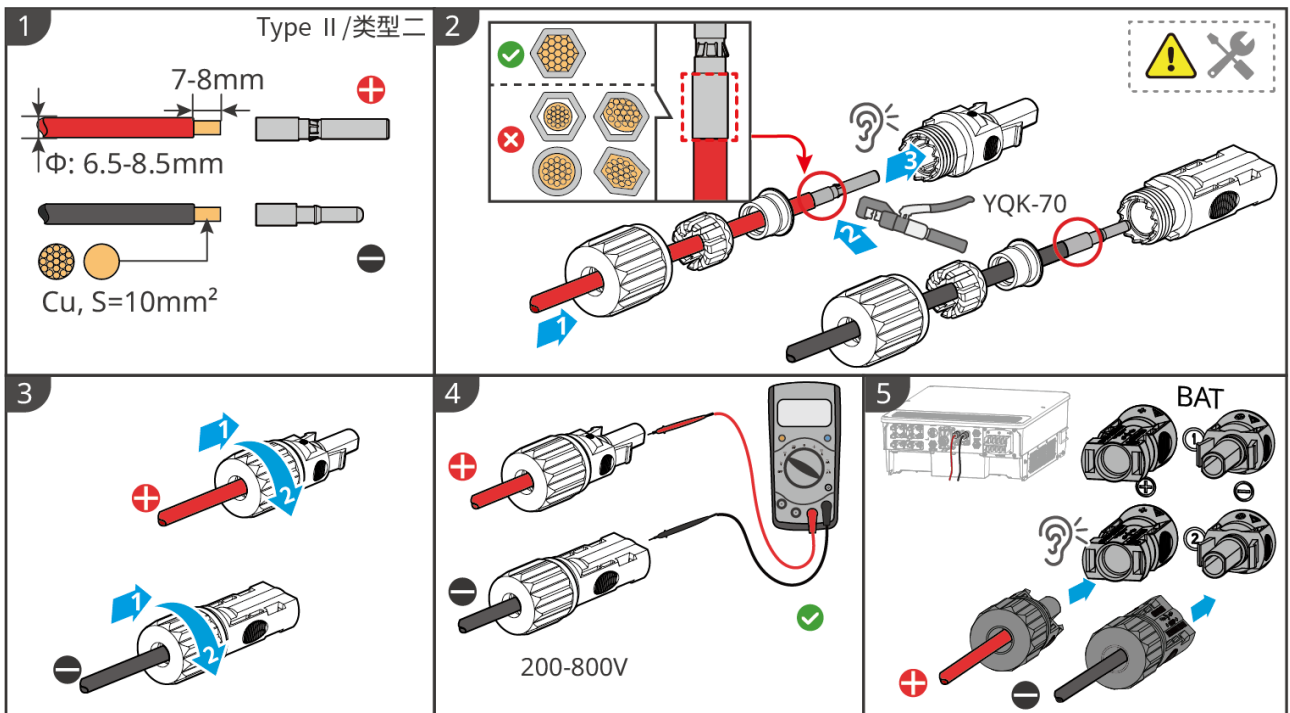

ET3010ELC0032

## Battery System Cluster Parallel Power Cable Preparation Method

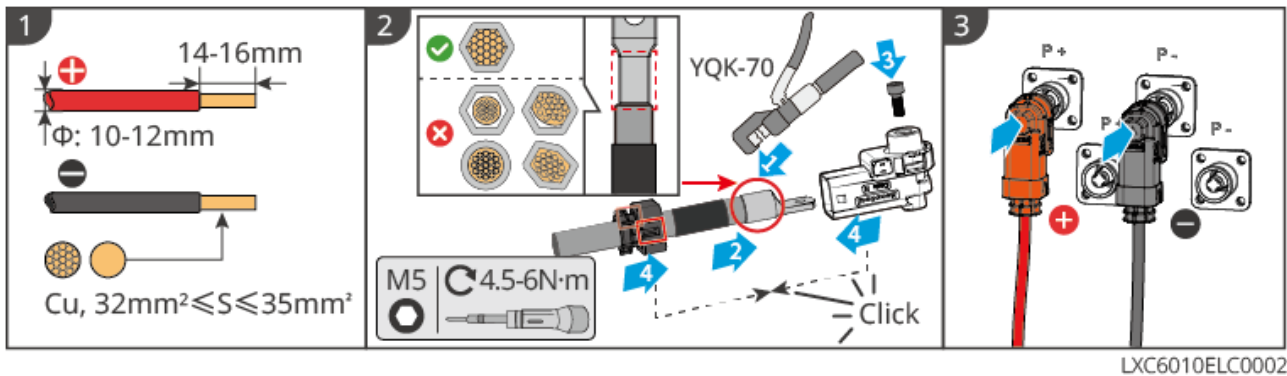

### 5.6.1.3 Connecting Battery Communication Cables

#### ⚠ WARNING

Do not omit the battery system terminal resistor, otherwise communication between battery systems will fail.

#### NOTICE

- The battery system is shipped with a BMS battery communication cable. It is recommended to use the provided BMS battery communication cable. If the provided cable does not meet the requirements, please prepare your own shielded network cable and shielded RJ45 connectors.
- Please connect the battery system to the BMS1 communication port of the inverter; otherwise, normal communication may not be possible.
- The emergency stop switch communication cable is pre-installed on the enclosure. If the provided communication cable does not meet the requirements, please prepare your own communication cable.
- For inter-cluster communication cables between battery systems, please prepare shielded network cables and shielded RJ45 connectors that meet the EIA/TIA-568B standard.
- PIN4 and PIN5 are for inverter communication only. Do not crimp PIN4 and PIN5 for inter-cluster communication cables between battery systems.
- When connecting battery systems in parallel clusters, connect the inverter remote shutdown port to the main battery system.

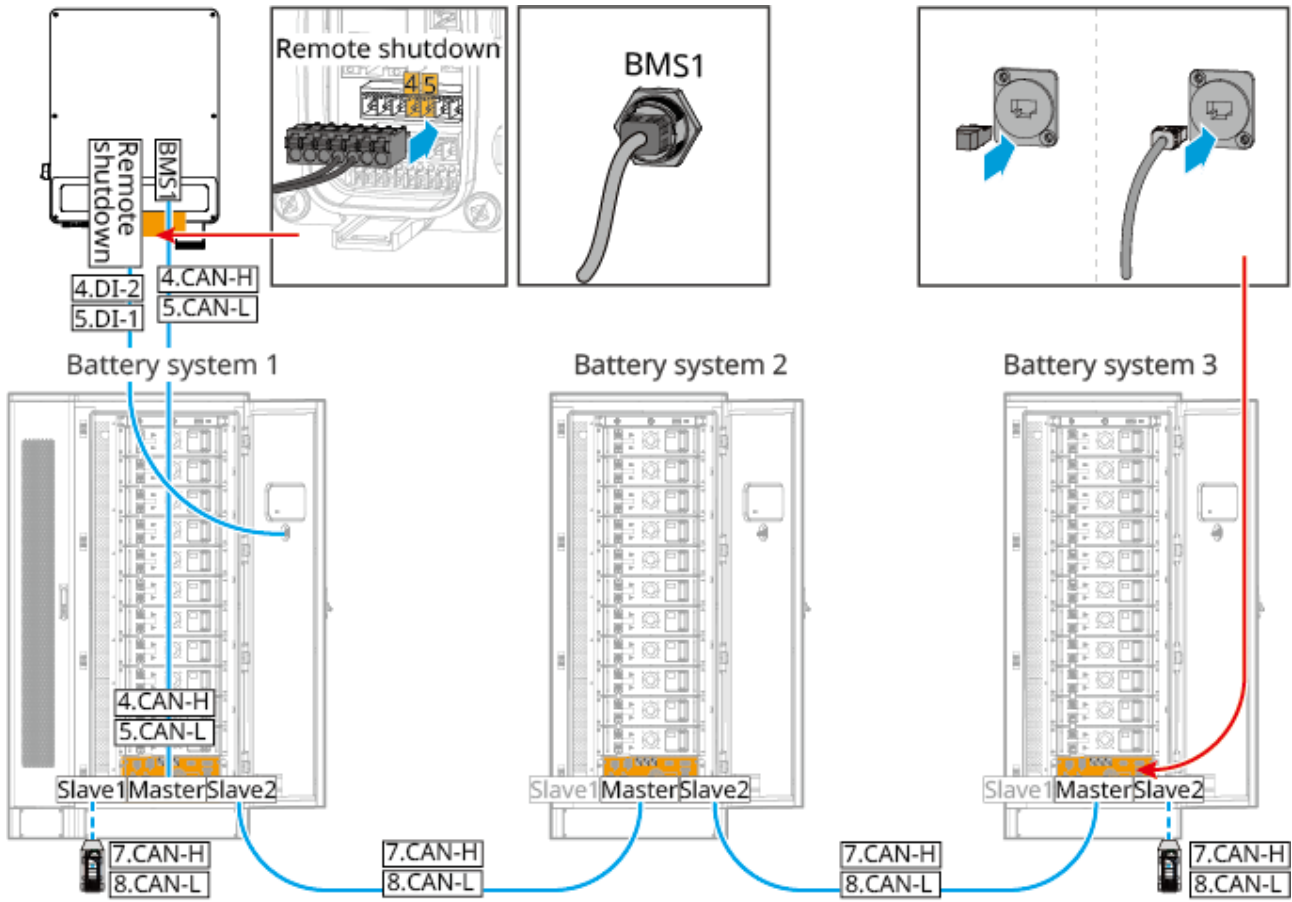

Lynx C 60kWh C&I

ET3010ELC0014

### Instructions for BMS Communication Connection Between Inverter and Battery:

Device	port	Definition	Description
Inverter	BMS1	4: CAN_H 5: CAN_L	CAN communication between the Inverter and the Battery
	Remote Shutdown	7: GND 8: Remote Shutdown	Connected to the battery system to control the Battery's emergency shutdown
Battery	Slave1	7: CAN_H 8: CAN_L	Parallel cluster CAN communication between Batteries
	Master	1: RS485_A1 2: RS485_B1	Reserved, for communication with the Inverter

Device	port	Definition	Description
		4: CAN_H 5: CAN_L	Communication with the Inverter
		7: CAN_H 8: CAN_L	Parallel cluster CAN communication between Batteries
	Slave2	7: CAN_H 8: CAN_L	Parallel cluster CAN communication between Batteries
	Emergency Stop Switch	1: NC 2: COM	Connected to the Inverter to control the Battery's emergency shutdown

### 5.6.1.4 Connecting Internal Power Busbars in Battery System

#### NOTICE

If the aluminum busbars in the battery system section were installed at the factory, please use tools to recheck the torque.

Scenario for shipment after installation of the inter-battery aluminum busbar section:

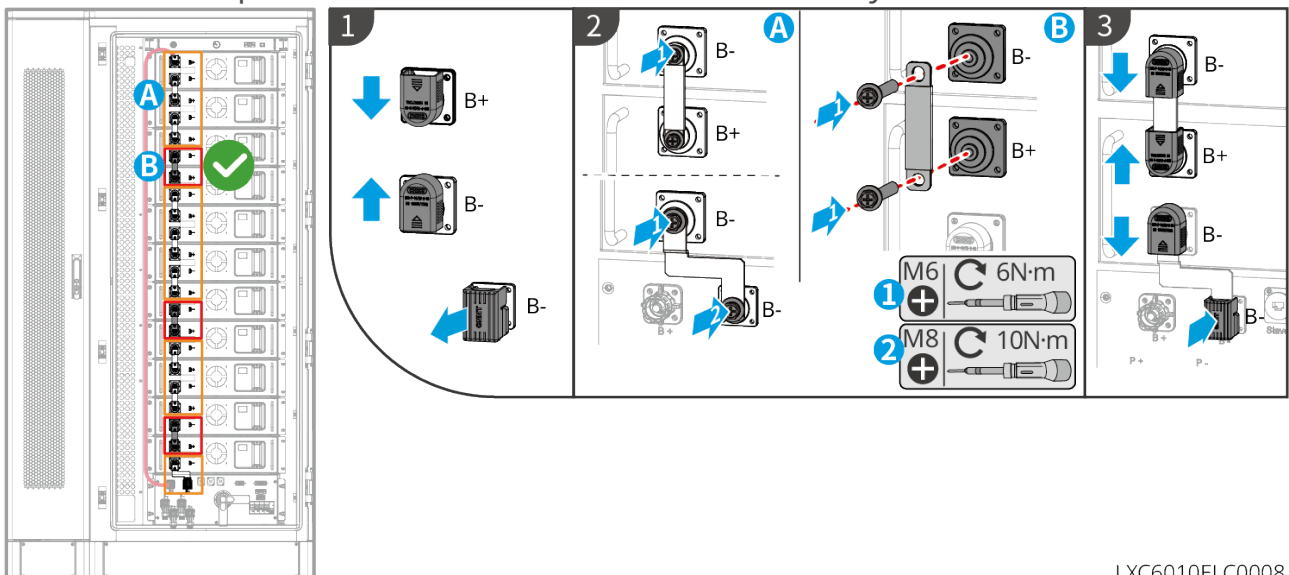

LXC6010ELC0008

Scenario for shipment without installation of the inter-battery aluminum busbars:

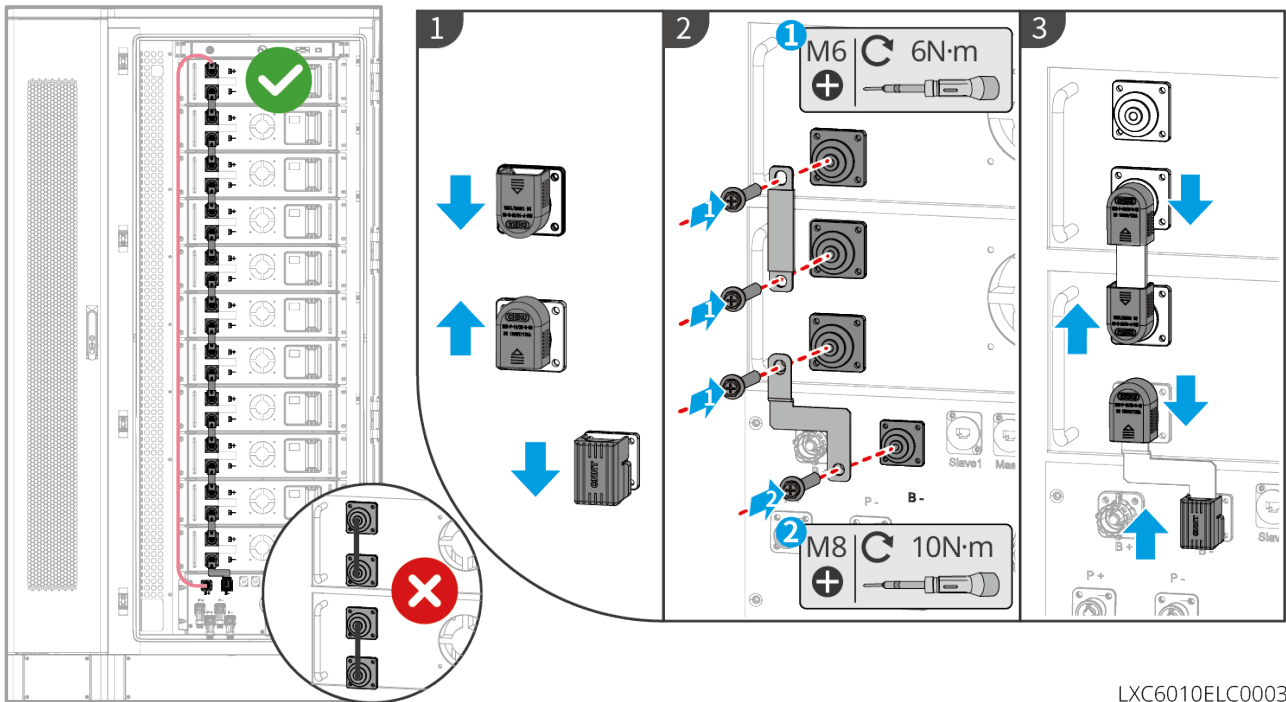

LXC6010ELC0003

### 5.6.1.5 Connect the Battery System Air Conditioning Power Cable

#### NOTICE

- The air conditioner power cord is pre-installed on the cabinet. If the provided power cord does not meet the requirements, please prepare your own extension cable.
- It is recommended to connect the air conditioner power cord to the distribution cabinet for power supply.
- If the air conditioner requires emergency power supply, you can connect the air conditioner power cord to the inverter BACK UP side for power.
- To ensure that the air conditioner can be safely disconnected from the distribution cabinet in case of abnormalities, please install an AC switch between the air conditioner and the distribution cabinet. The AC switch specification should be no less than 16A.
- To ensure heat dissipation performance, do not arbitrarily modify the default temperature parameter settings of the air conditioner.

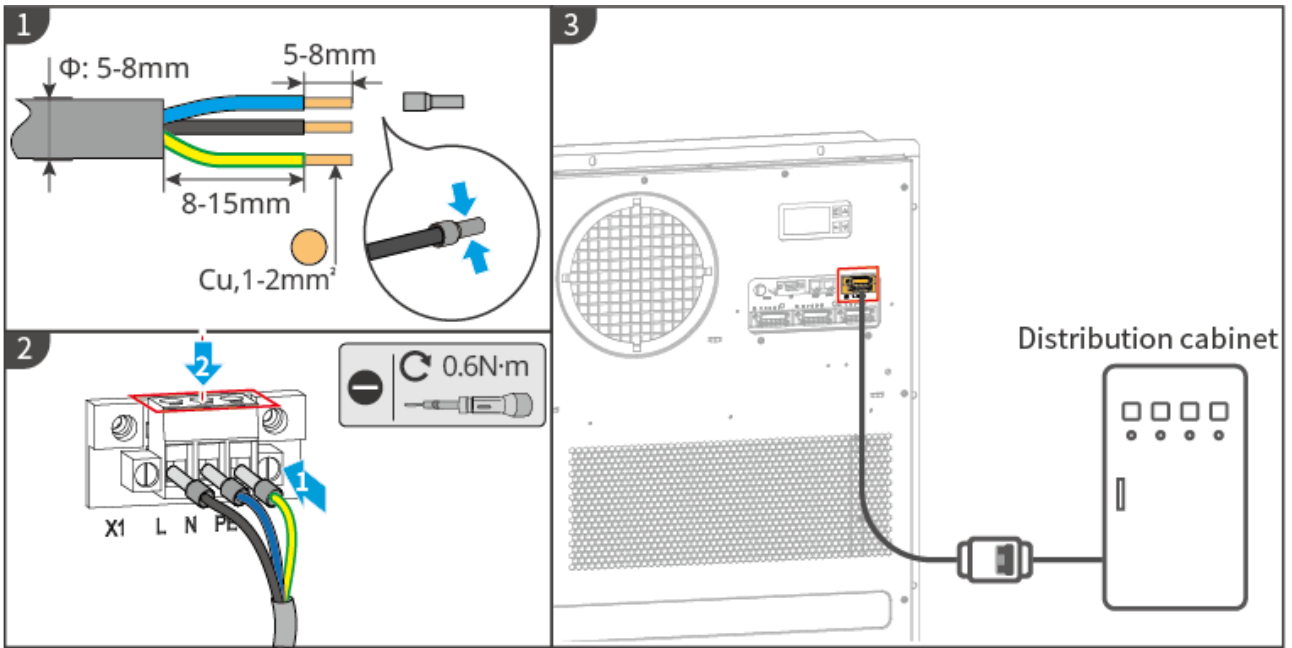

LXC6010ELC0006

### 5.6.1.6 Connecting the Battery System Air Conditioning Drain Pipe

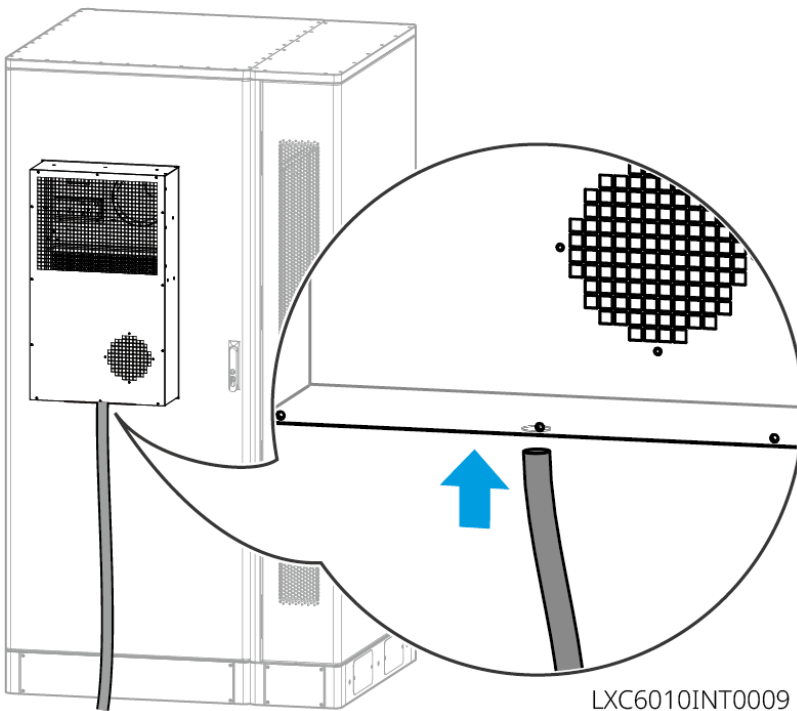

LXC6010INT0009

### 5.6.1.7 Open Fire Switch

## NOTICE

The "open" (turn on) and "close" (turn off) functions of the firefighting equipment can only be enabled during professional maintenance or replacement operations of the thermal activation element.

Fire Equipment Switch Operation Scenario:

- If a 'Do Not Move' label is present, no operation is required.

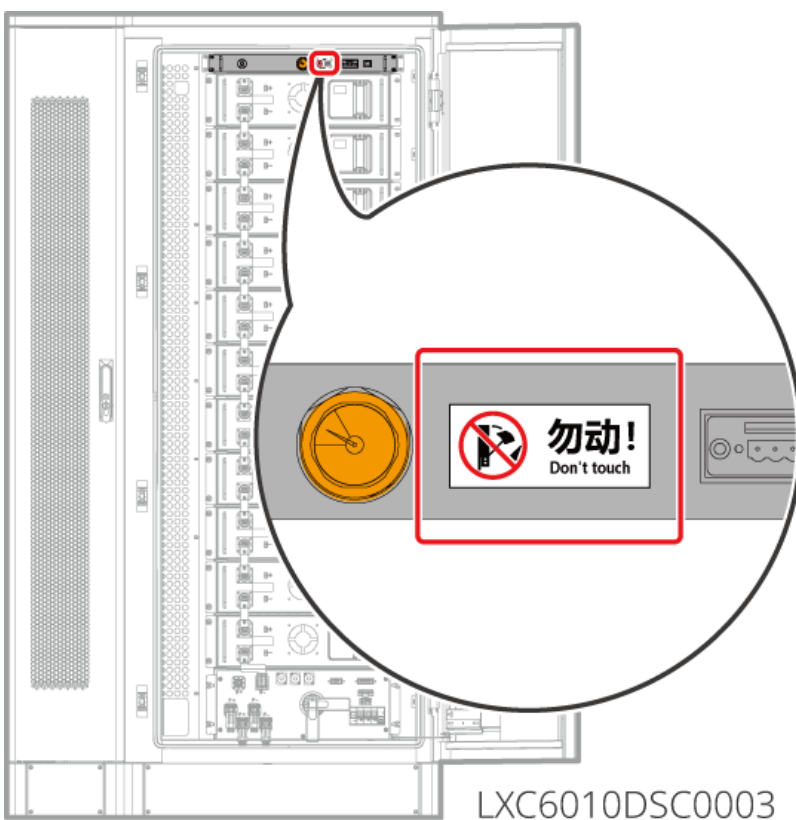

- If no label is present, please refer to the following steps to open the fire switch. Use a 14mm wrench to rotate the screw behind the pressure gauge counterclockwise approximately 1.5 turns until fully tightened, and the fire system will be successfully activated.

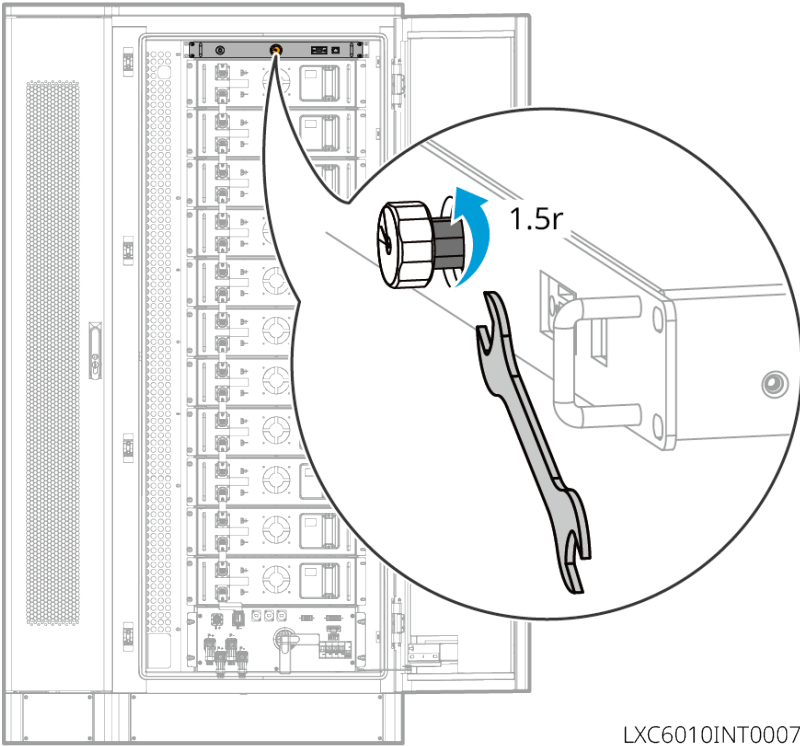

LXC6010INT0007

### 5.6.1.8 Mounting Panel

After the cable connection is completed, install the bottom panel.

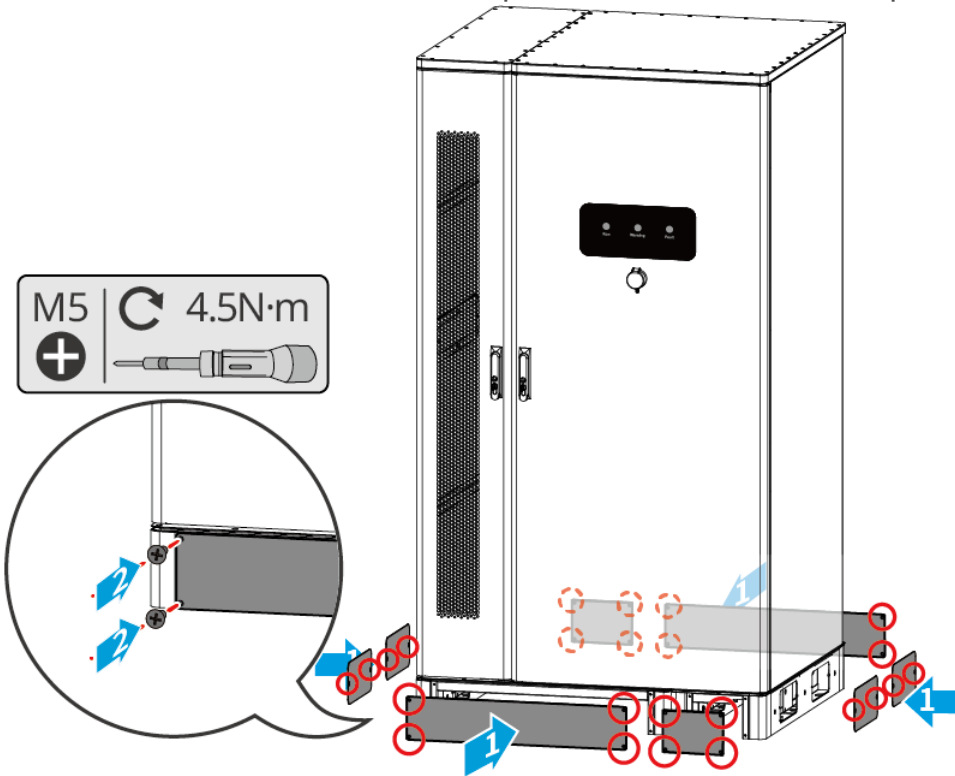

LXC6010INT0008

## 5.6.2 Compatible with BAT-S Series 25.6-56.3kWh High-Voltage Battery

### 5.6.2.1 Connecting the Power Cable between the Inverter and Battery

#### NOTICE

The BAT-S Series 25.6-56.3kWh high-voltage battery supports up to 6 battery cabinet clusters in parallel.

#### Wiring Overview

- The 15-20kW inverter has only 1 BAT port; connect 1 circuit when used with a battery.

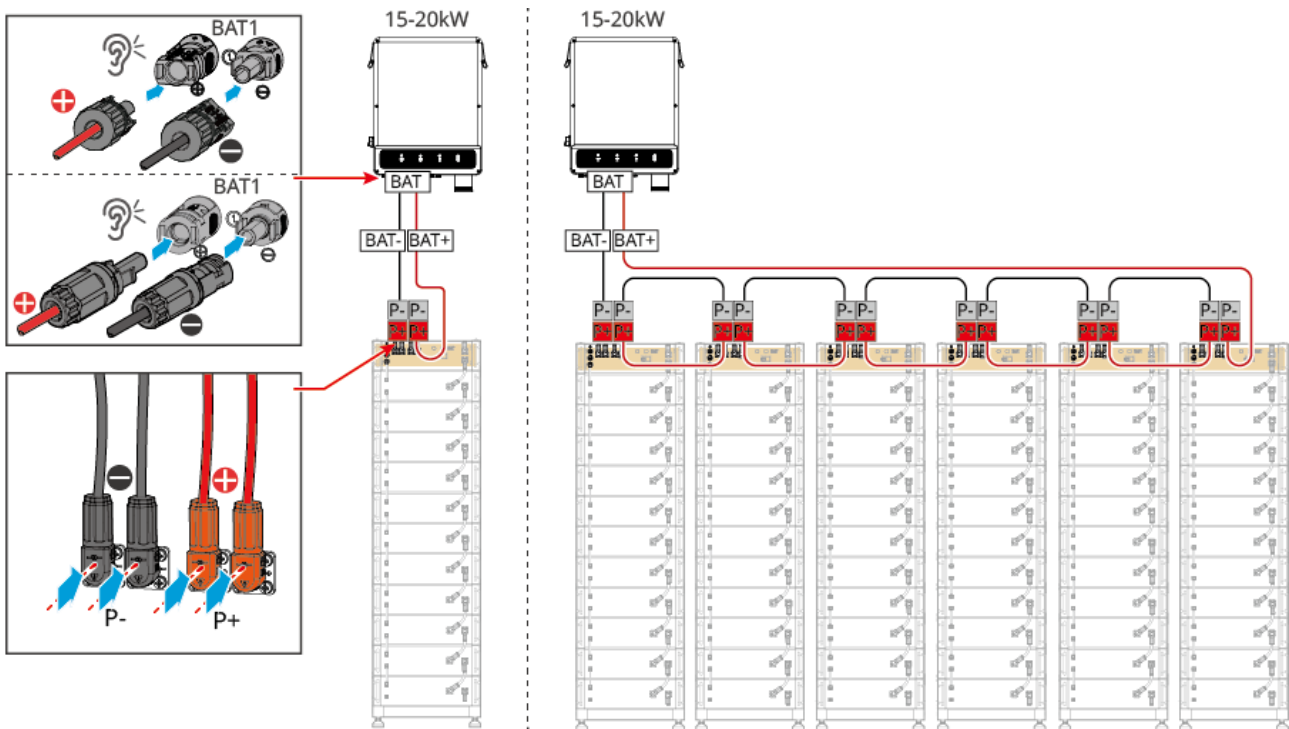

ET3010ELC0038

- The 25-30kW inverter has 2 BAT ports; connect 2 circuits when used with a battery.

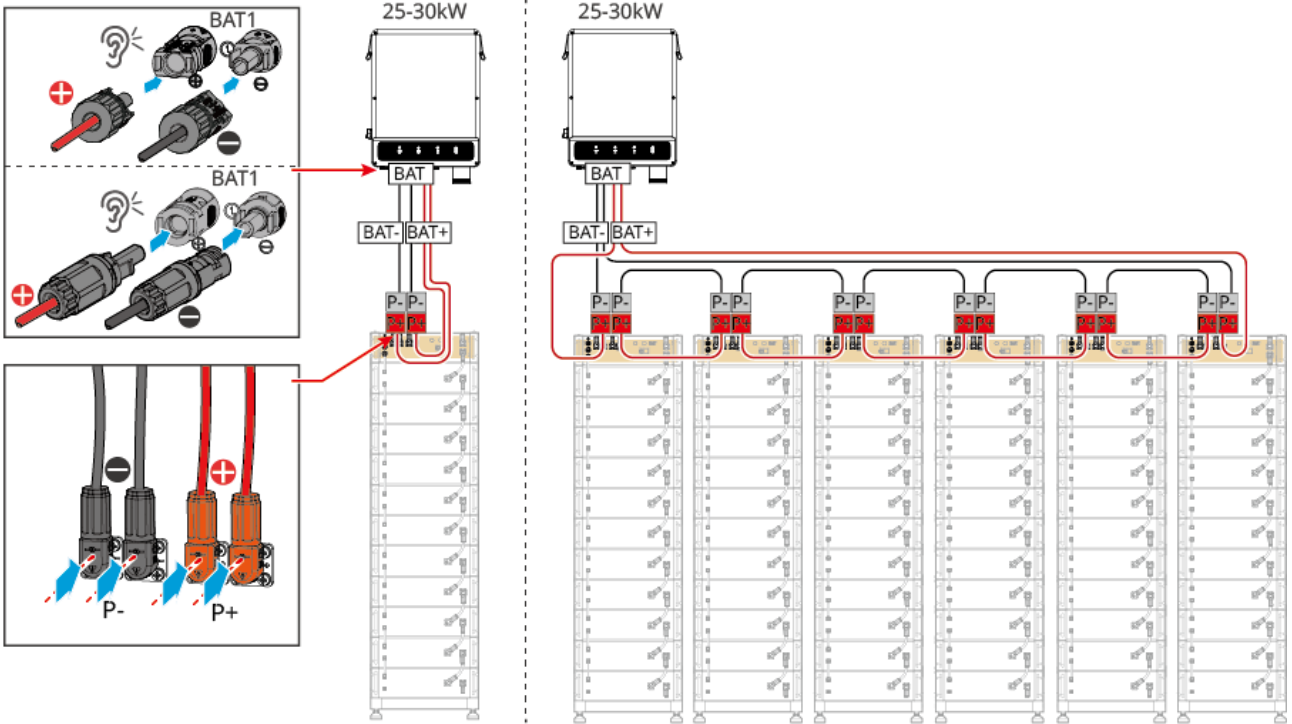

ET3010ELC0039

### Inverter-Side Cable Preparation Method

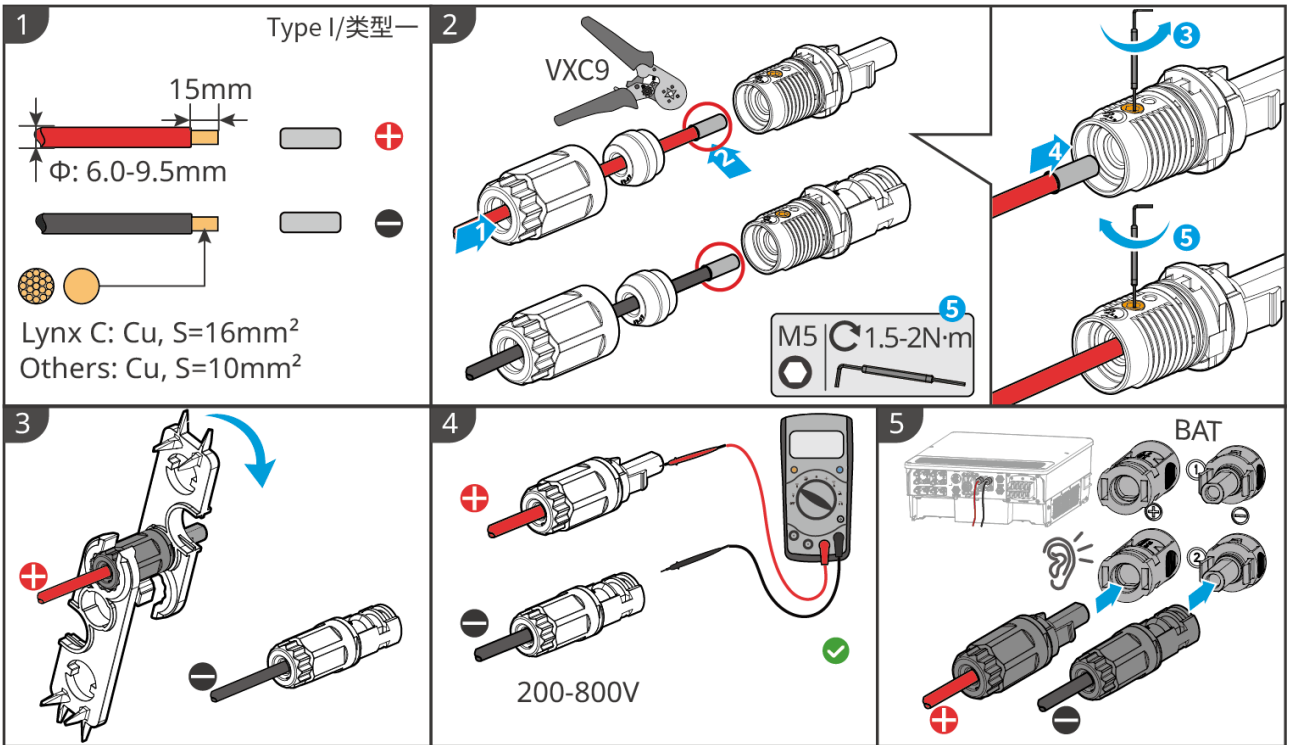

ET3010ELC0031

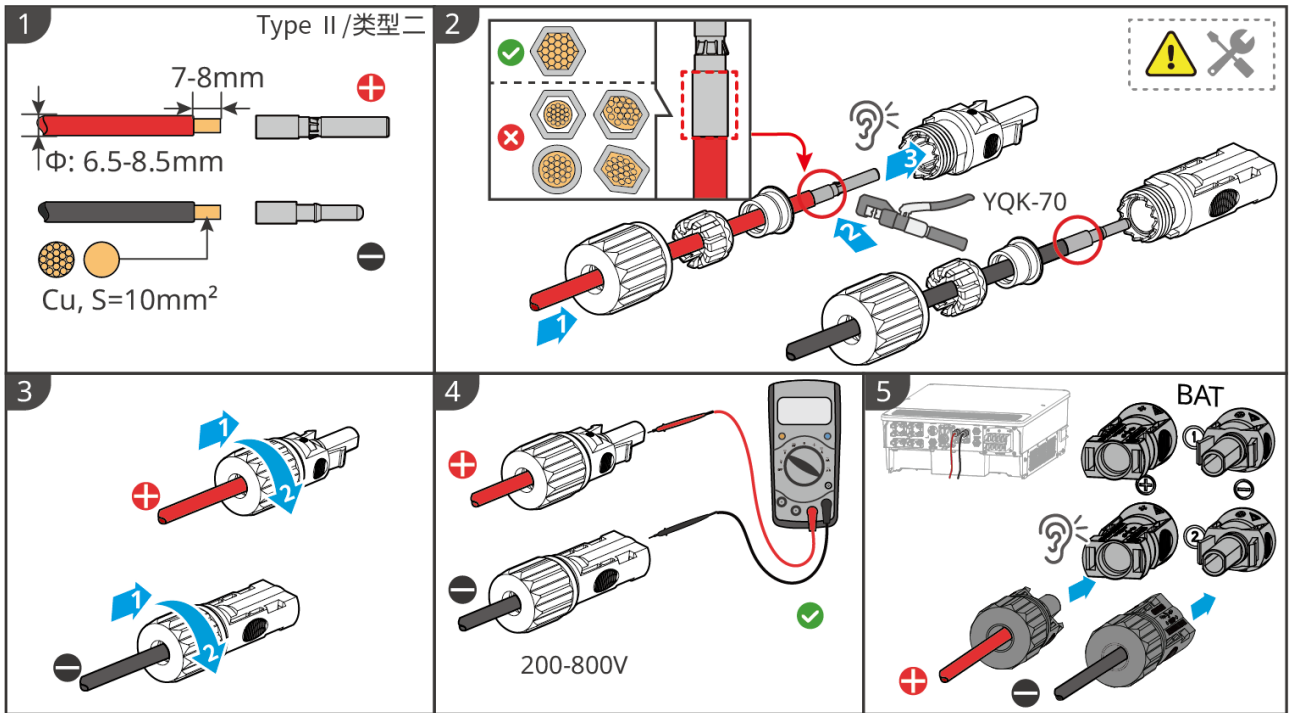

### Battery-Side Cable Preparation Method (Including Parallel Cluster Wiring)

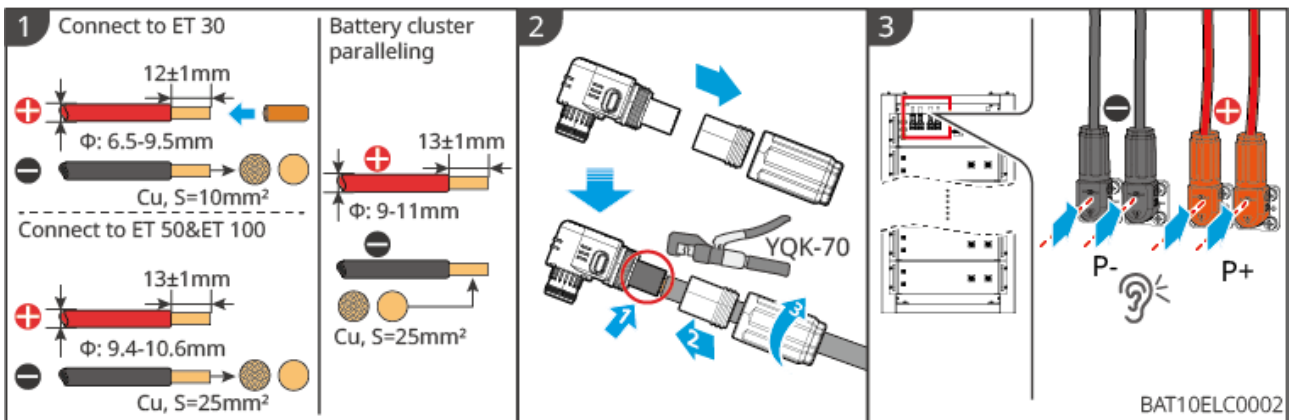

### 5.6.2.2 Connecting Power Cables Between Batteries

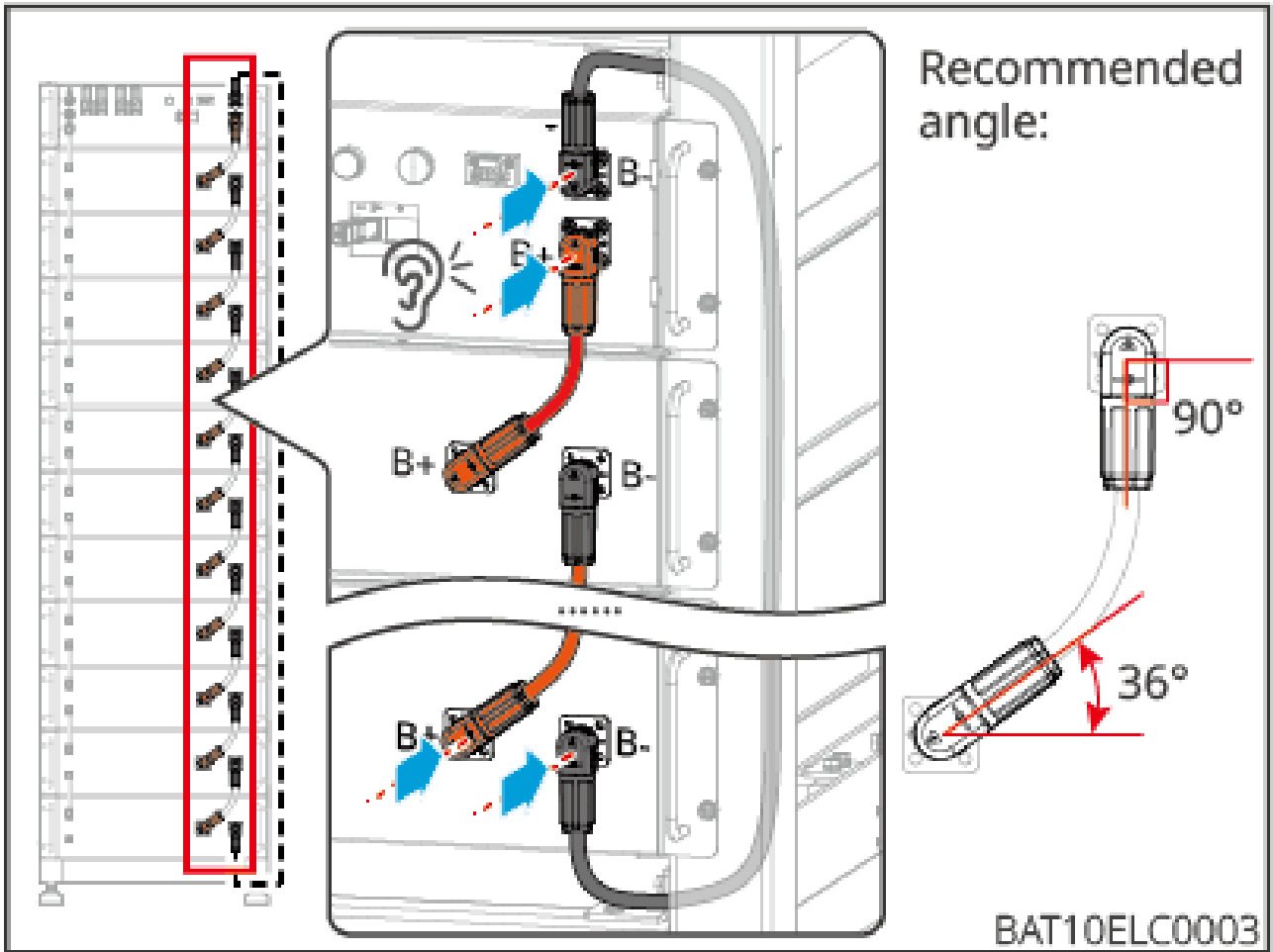

### 5.6.2.3 Connecting Communication Cables

#### NOTICE

The battery system includes a communication cable with the box. Please use the communication cable provided with the box.

Explanation of BMS Communication Connection Between Inverter and Battery:

Port	Definition	Description
COM1、COM2	1: RS485_A1 2: RS485_B1	Communication with inverter (reserved).
	4: CAN_H 5: CAN_L	Communication with inverter or cluster parallel communication.

## Inverter to Battery Communication Wiring

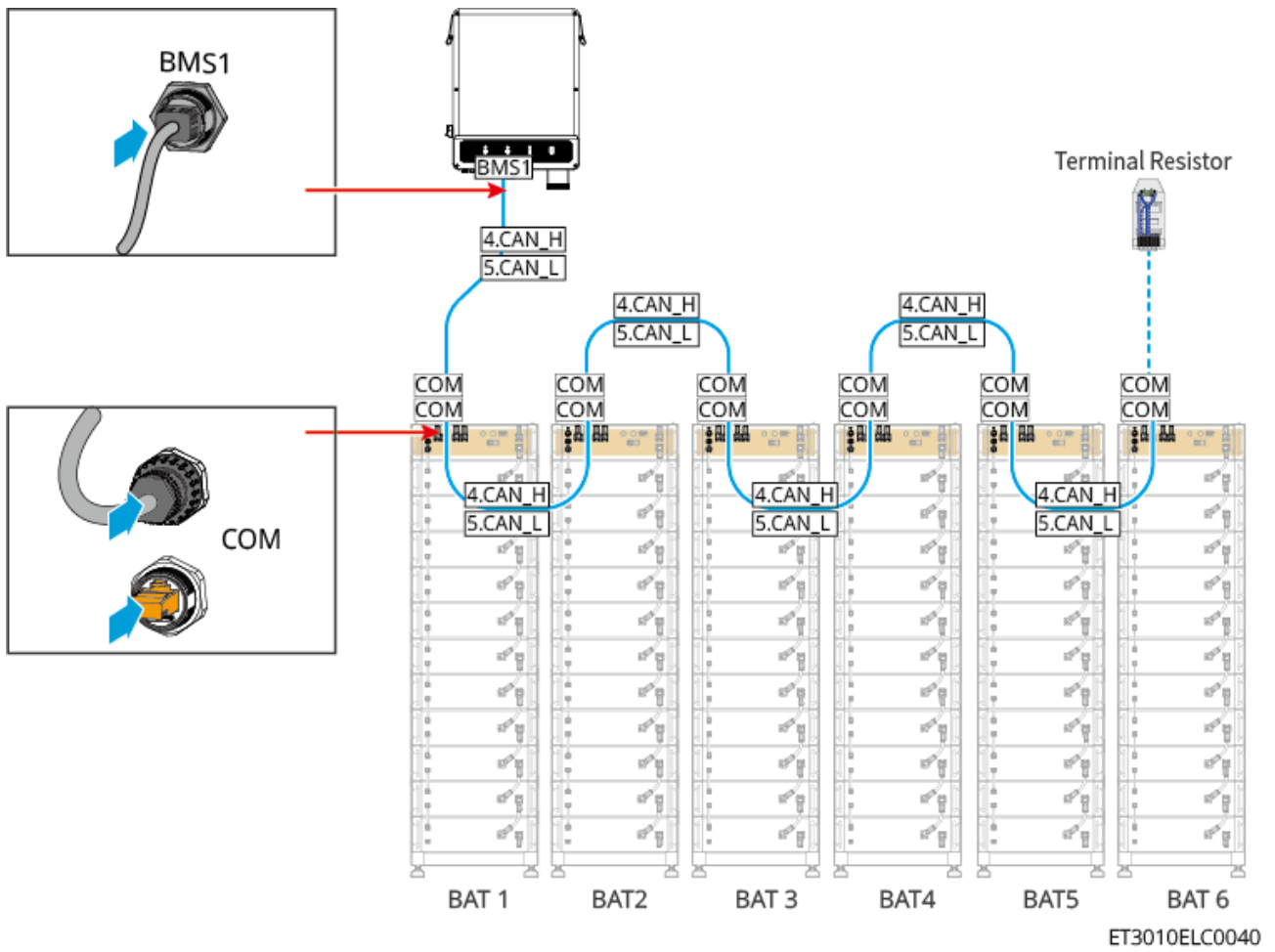

## Battery PACK to PACK Communication Wiring

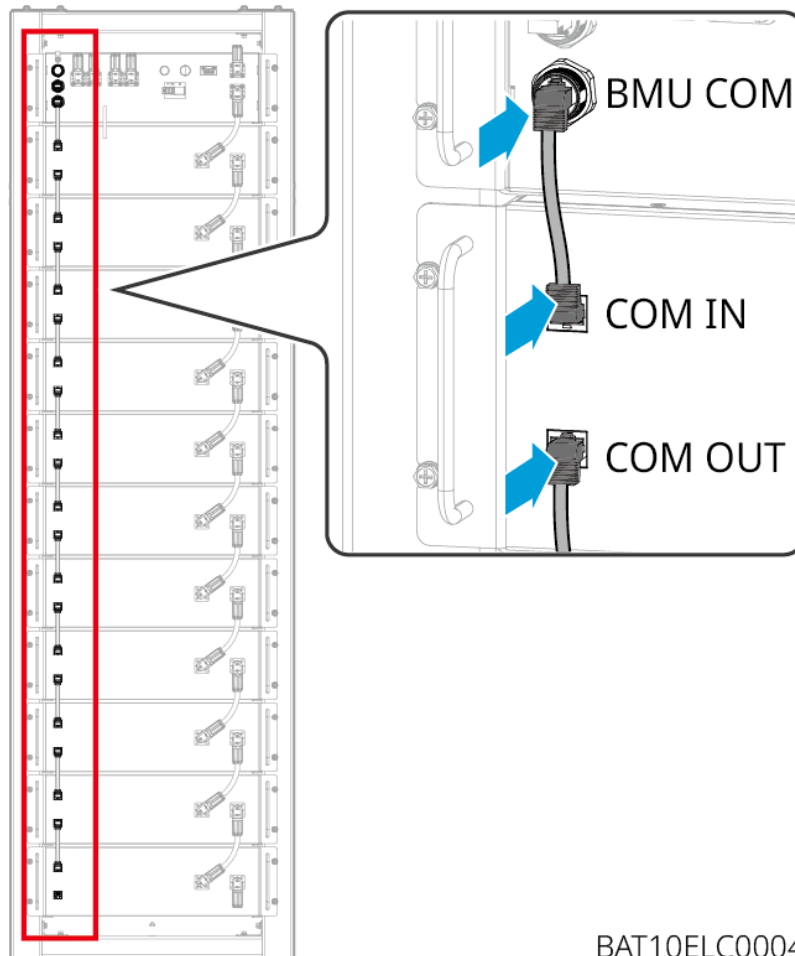

BAT10ELC0004

### NOTICE

When connecting the communication cables between battery PACKs, the COM OUT port of the bottom-most PACK should not be connected; no terminal resistor is required!

### 5.6.3 Paired with BAT-C Series 61.4-112.6kWh Commercial and Industrial Battery System

Inverter	GW15K-ET	GW20K-ET	GW25K-ET	GW29.9K-ET	GW30K-ET
Number of BAT ports	1	1	2	2	2

Inverter		GW15K-ET	GW20K-ET	GW25K-ET	GW29.9K-ET	GW30K-ET
With BAT 61.4kWh battery system	Connection method	Connect to 1 BAT port	Connect to 1 BAT port	Connect to 2 BAT ports	Connect to 2 BAT ports	Connect to 2 BAT ports
	Can it be fully loaded?	Yes	No	Yes	Yes	Yes
With BAT 92.1kWh battery system	Connection method	Connect to 1 BAT port	Connect to 1 BAT port	Connect to 2 BAT ports	Connect to 2 BAT ports	Connect to 2 BAT ports
	Can it be fully loaded?	Yes	Yes	Yes	Yes	Yes
With BAT 102.4kWh battery system	Connection method	Connect to 1 BAT port	Connect to 1 BAT port	Connect to 1 BAT port	Connect to 2 BAT ports	Connect to 2 BAT ports
	Can it be fully loaded?	Yes	Yes	Yes	Yes	Yes
With BAT 112.6kWh battery system	Connection method	Connect to 1 BAT port	Connect to 1 BAT port	Connect to 1 BAT port	Connect to 2 BAT ports	Connect to 2 BAT ports
	Can it be fully loaded?	Yes	Yes	Yes	Yes	Yes

### 5.6.3.1 Battery Wire Pass-Through Holes and System Wiring Introduction

 **WARNING**

All cut wire access holes must be sealed with fireproof putty.

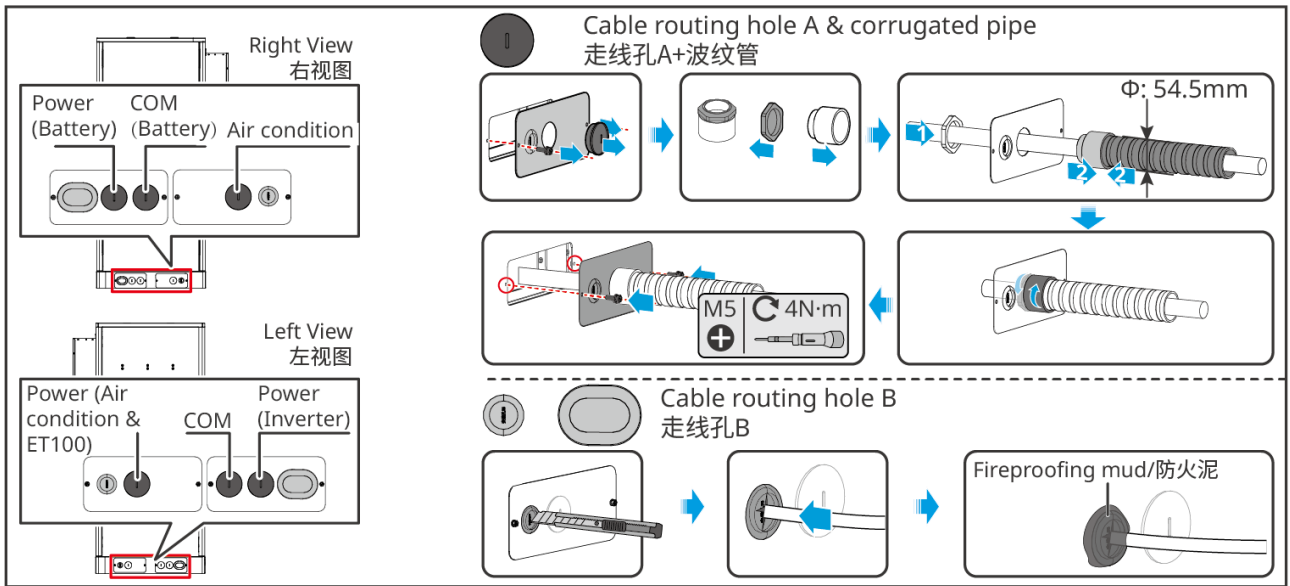

BAT10INT0014

### 5.6.3.2 Connecting the Power Cable between the Inverter and Battery

#### Inverter End Cable Preparation Method

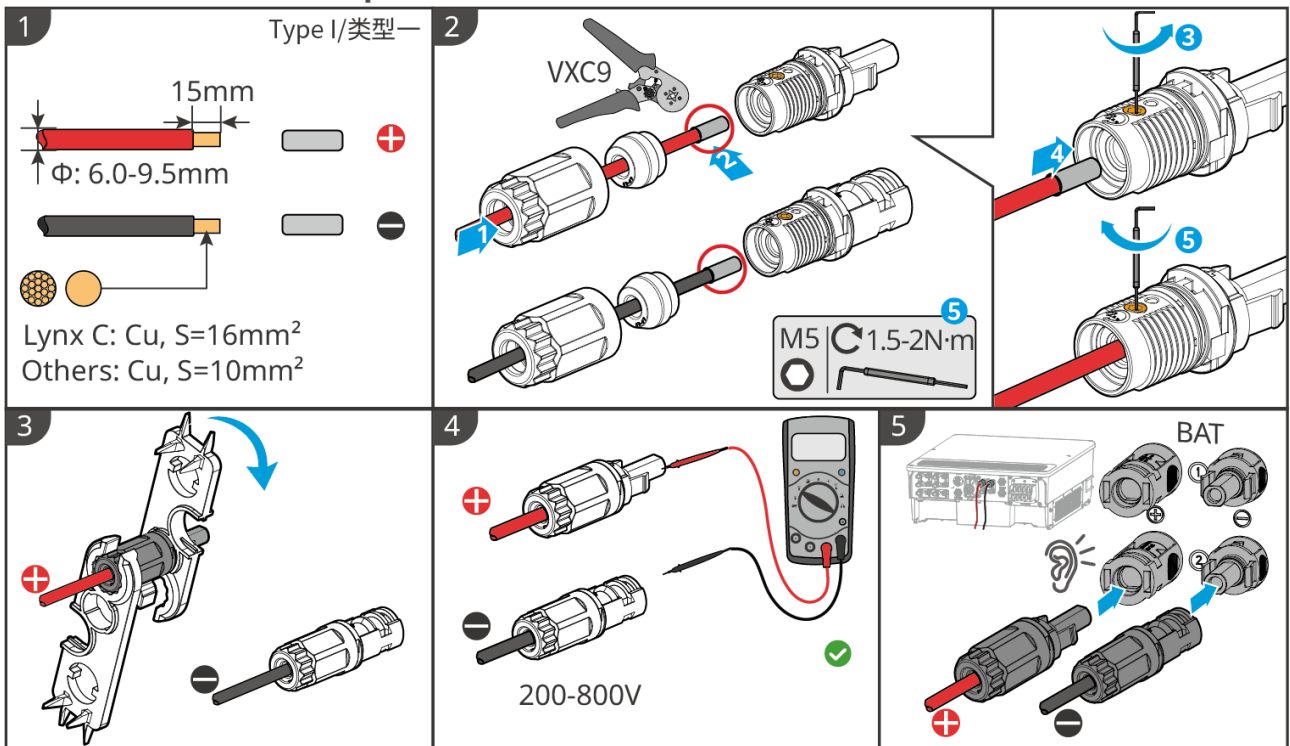

ET3010ELC0031

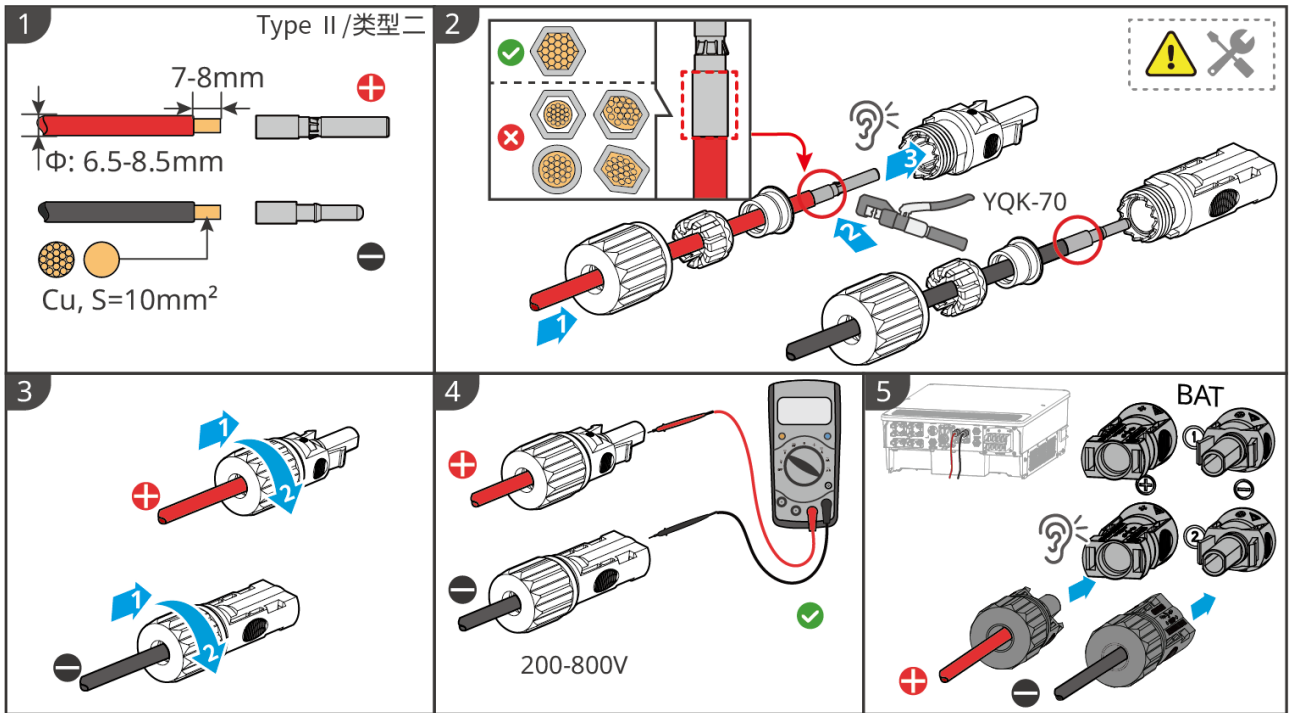

ET3010ELC0032

### Battery End Cable Preparation Method

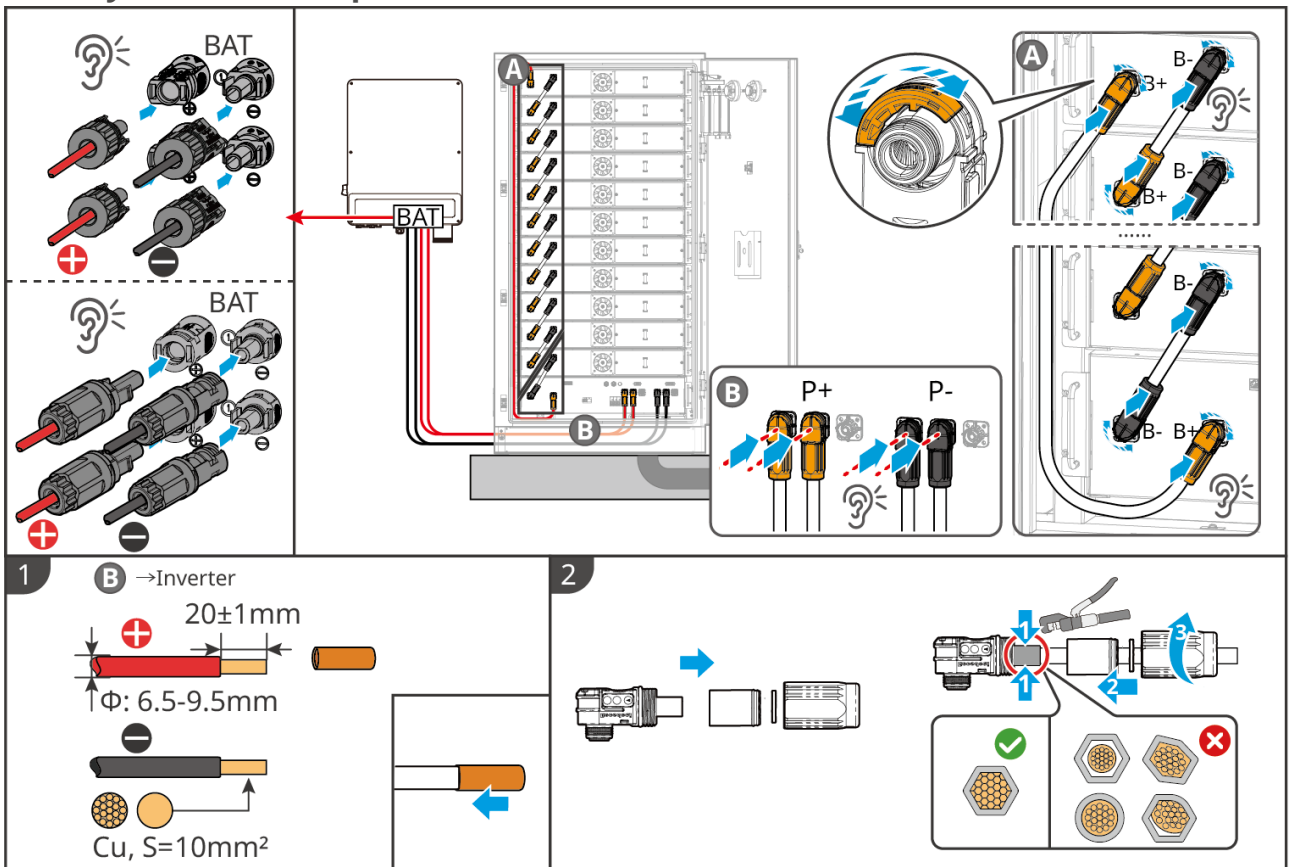

BAT10ELC0011

### 5.6.3.3 Connecting the Battery Communication Cable

#### NOTICE

- The battery system comes with a communication cable included in the box. Please use the provided communication cable.
- The external communication port of the battery system is pre-installed with a terminal resistor. If you need to connect a communication cable, please remove the terminal resistor. Keep the terminal resistor on ports not connected to a communication cable.

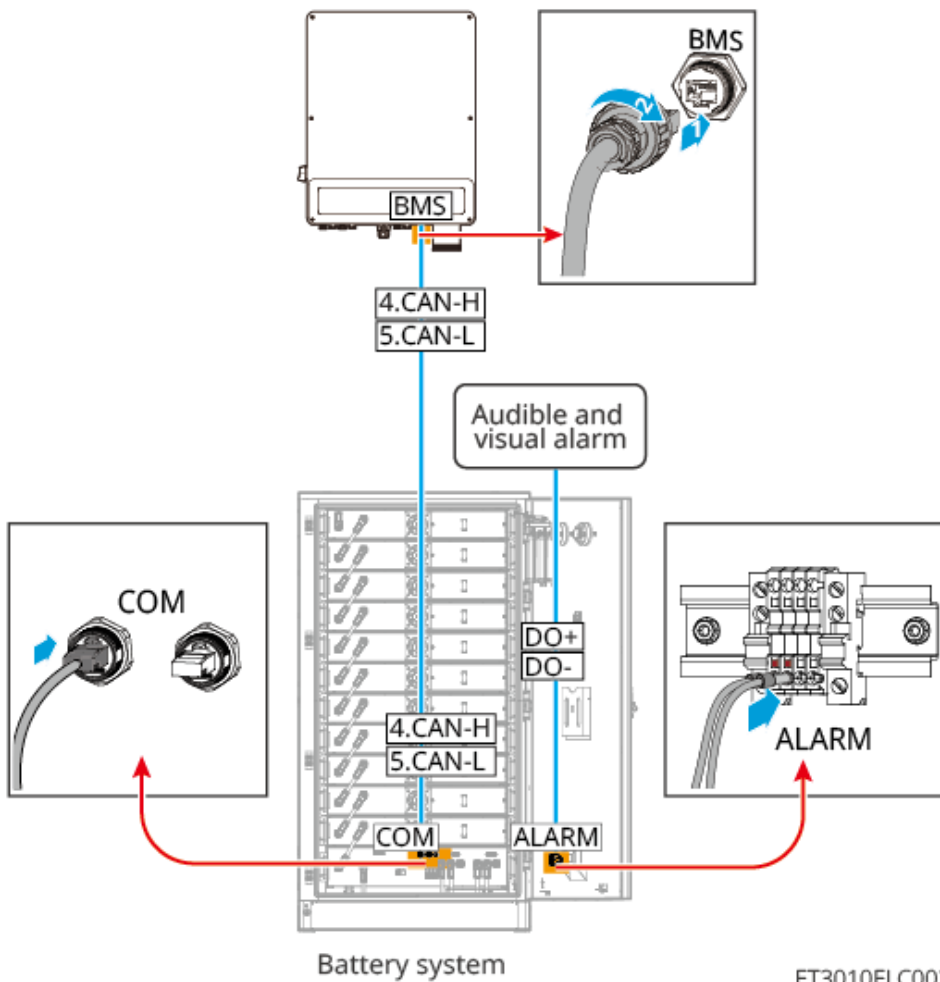

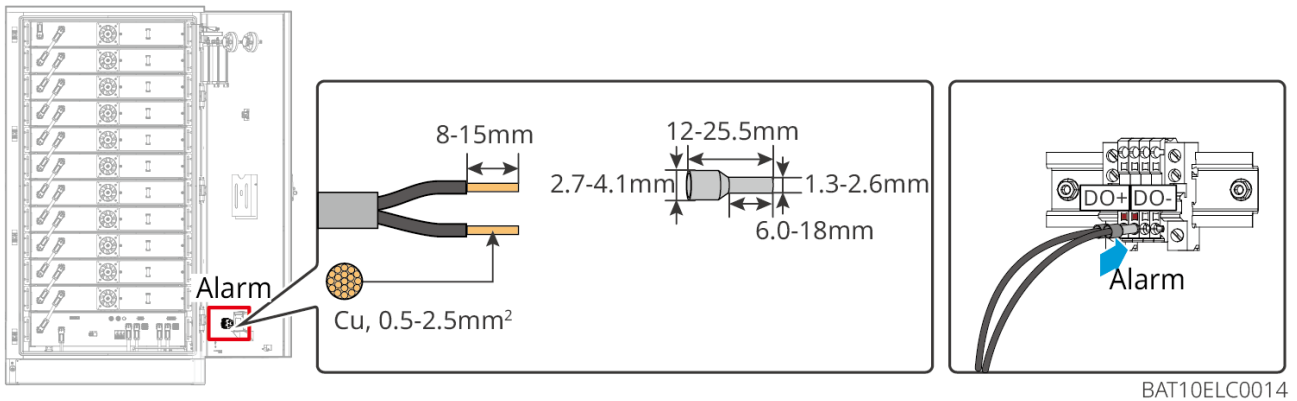

### Instructions for BMS Communication Connection between Inverter and Battery:

port	definition	description
1-3, 6-8	-	-
4	CAN_H	Communication with inverter
5	CAN_L	

#### 5.6.3.4 Connecting Battery Air Conditioning Cables

##### Wiring Steps:

Step 1: Make the air conditioning cable.

Step 2: Connect the cable to the battery's AC switch.

Step 3: Connect the cable directly to the distribution board or to the inverter's BACKUP port via the distribution board.

#### NOTICE

Please ensure the voltage of the air conditioner power cord is 220V  $\pm$ 15% and the rated current is 12A.

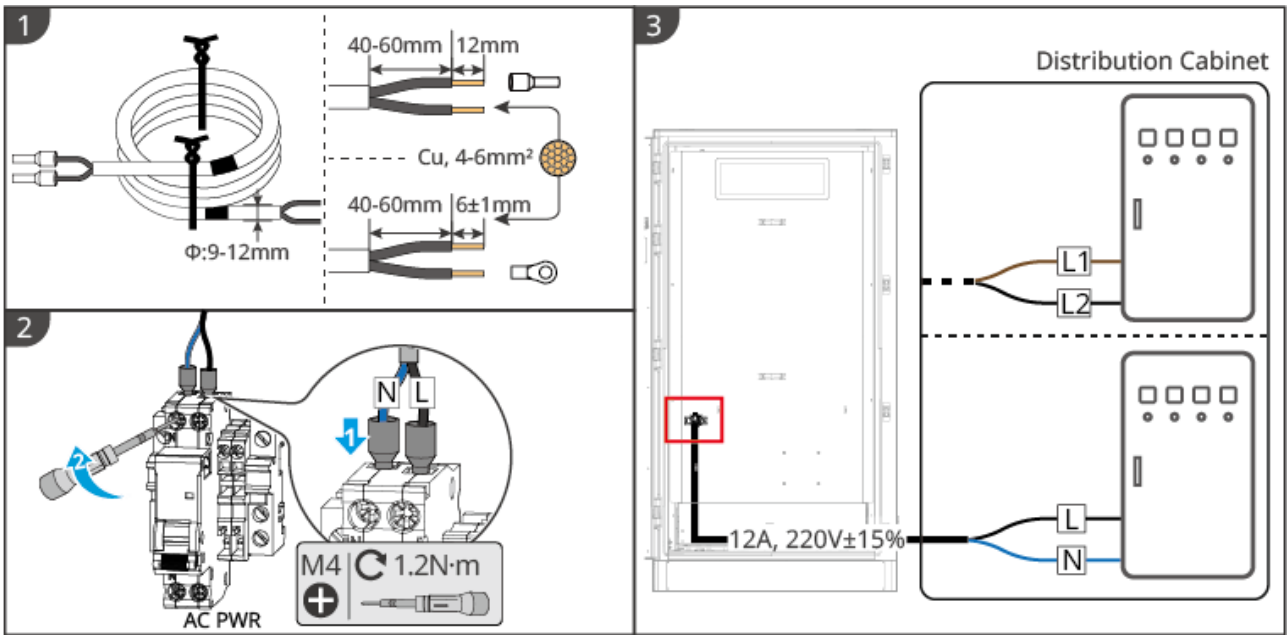

BAT10ELC0016

### 5.6.3.5 Install Base Plate and Release Emergency Stop Switch

After wiring is complete, reinstall the battery bottom cover along its original path, and rotate right to release the emergency stop switch.

Pedestal installation

安装底板

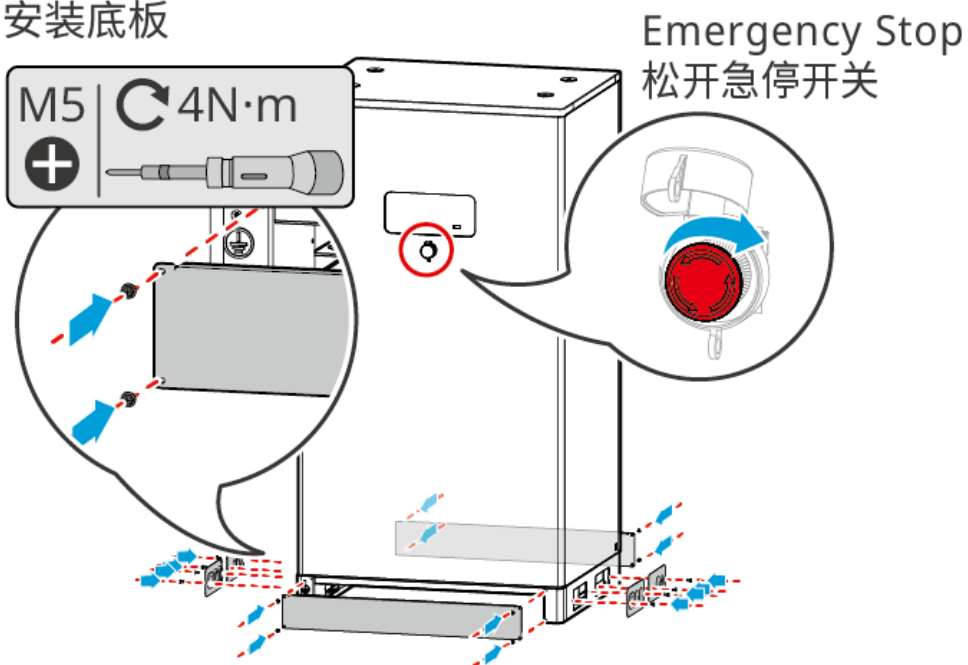

BAT10INT0009

## 5.7 Connecting the AC Cable



- The inverter integrates a Residual Current Monitoring Unit (RCMU) internally to prevent the residual current from exceeding the specified value. When the inverter detects a leakage current greater than the permissible value, it will quickly disconnect from the grid or generator.
- During wiring, ensure the AC wires fully match the "L1", "L2", "L3", "N", and "PE" ports of the AC terminals. Incorrect cable connection will cause equipment damage.
- Ensure the wire cores are fully inserted into the terminal wiring holes with no exposed parts.
- Ensure the insulation plate at the AC terminal is tightly secured and not loose.
- Ensure the cable connections are tight. Otherwise, during equipment operation, the terminal may overheat and cause equipment damage.

Type 1:

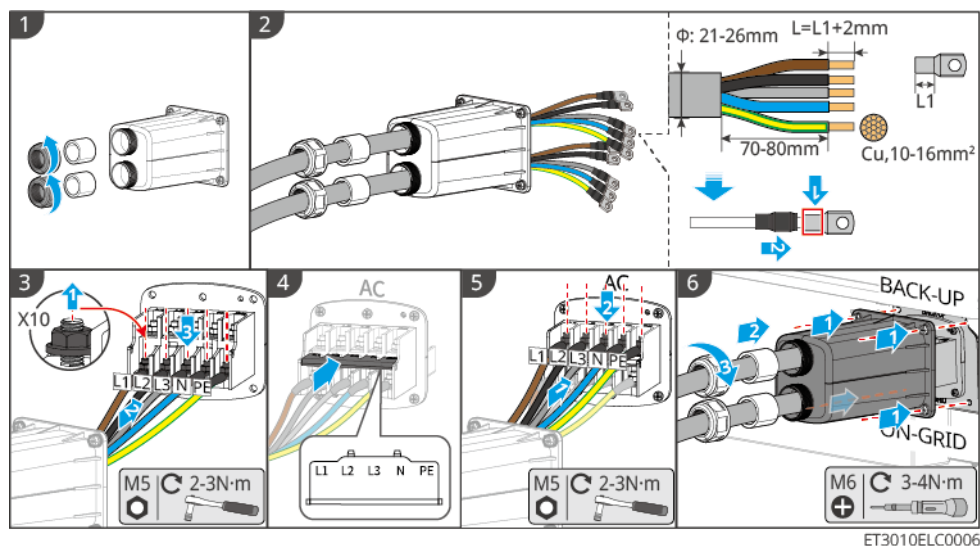

Type 2:

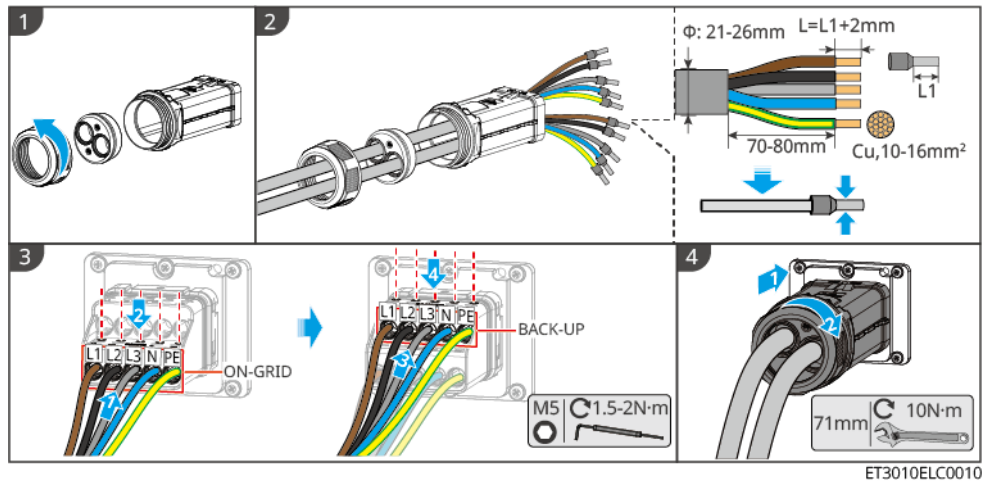

## 5.8 Connecting the Meter Cable

### NOTICE

- The meter shipped with the box is for use with only one inverter. Do not connect one meter to multiple inverters. If you need to use multiple inverters, consult the manufacturer to purchase a meter separately.
- Ensure that the CT connection direction and phase sequence are correct; otherwise, it may result in inaccurate monitoring data.
- Ensure that all cables are connected correctly, securely, and without looseness. Improper wiring may cause poor contact or damage to the meter.
- In areas with lightning hazards, if the meter cable length exceeds 10m and the cables are not wired using grounded metal conduits, it is recommended to install external lightning protection devices.

### GM3000 Meter Wiring

## NOTICE

- The outer diameter of the AC power line must be smaller than the aperture of the CT to ensure the AC power line can pass through the CT.
- To ensure the current detection accuracy of the CT, the recommended CT cable length should not exceed 30m.
- Do not use network cables as CT cables, as excessive current may cause damage to the meter.
- The CTs provided by device manufacturers may vary slightly in size and appearance depending on the model, but the installation and wiring methods are the same.

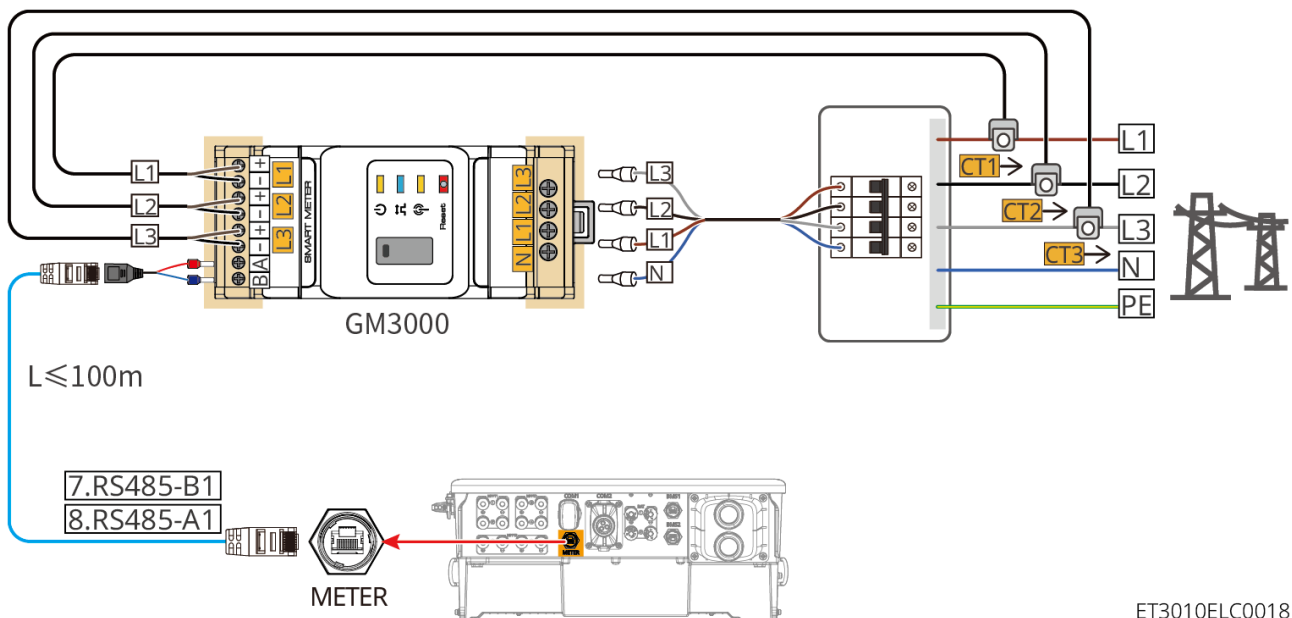

ET3010ELC0018

### Wiring Steps

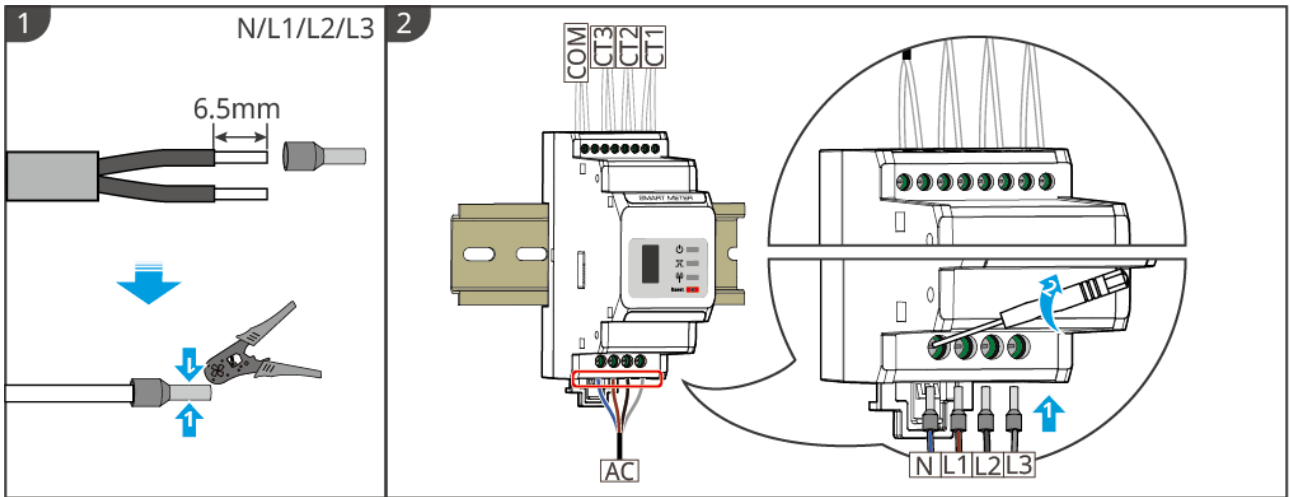

GMK10ELC003

### GM330 & GMK330 Meter Wiring

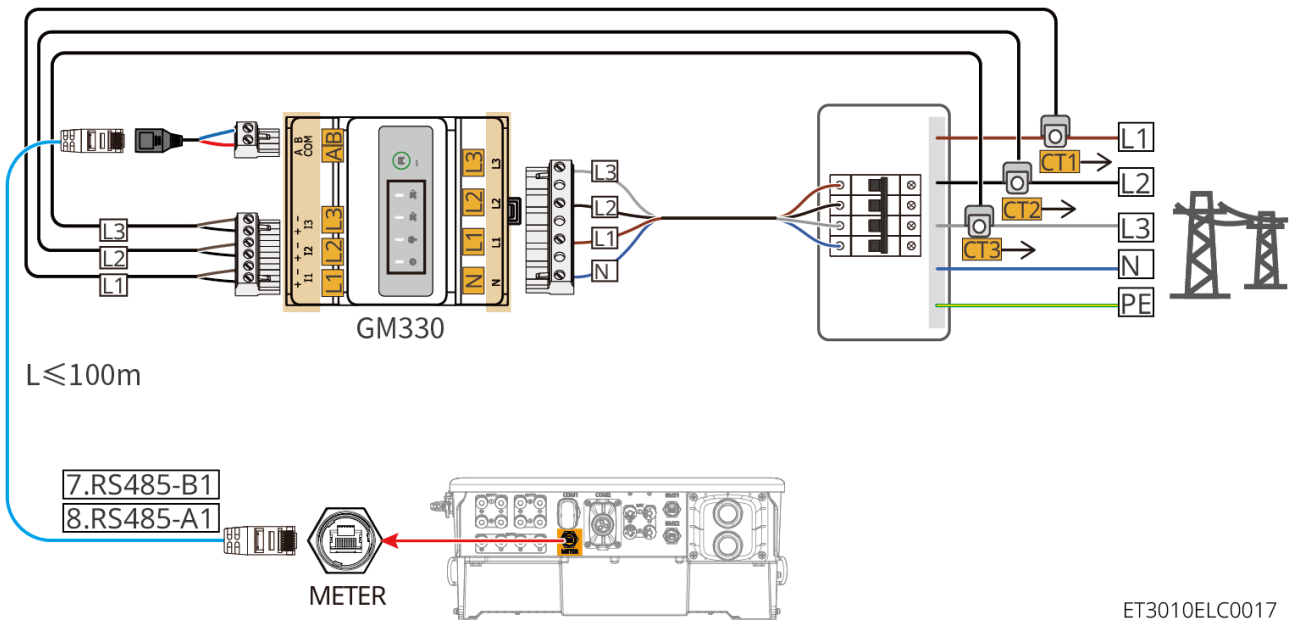

ET3010ELC0017

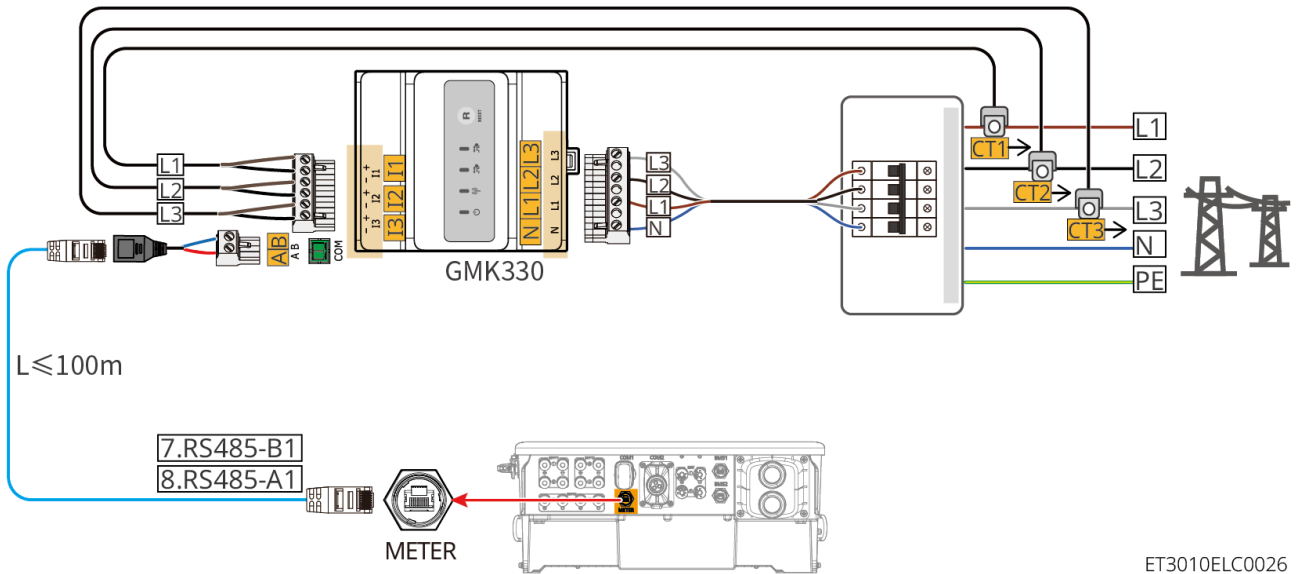

## Wiring Steps

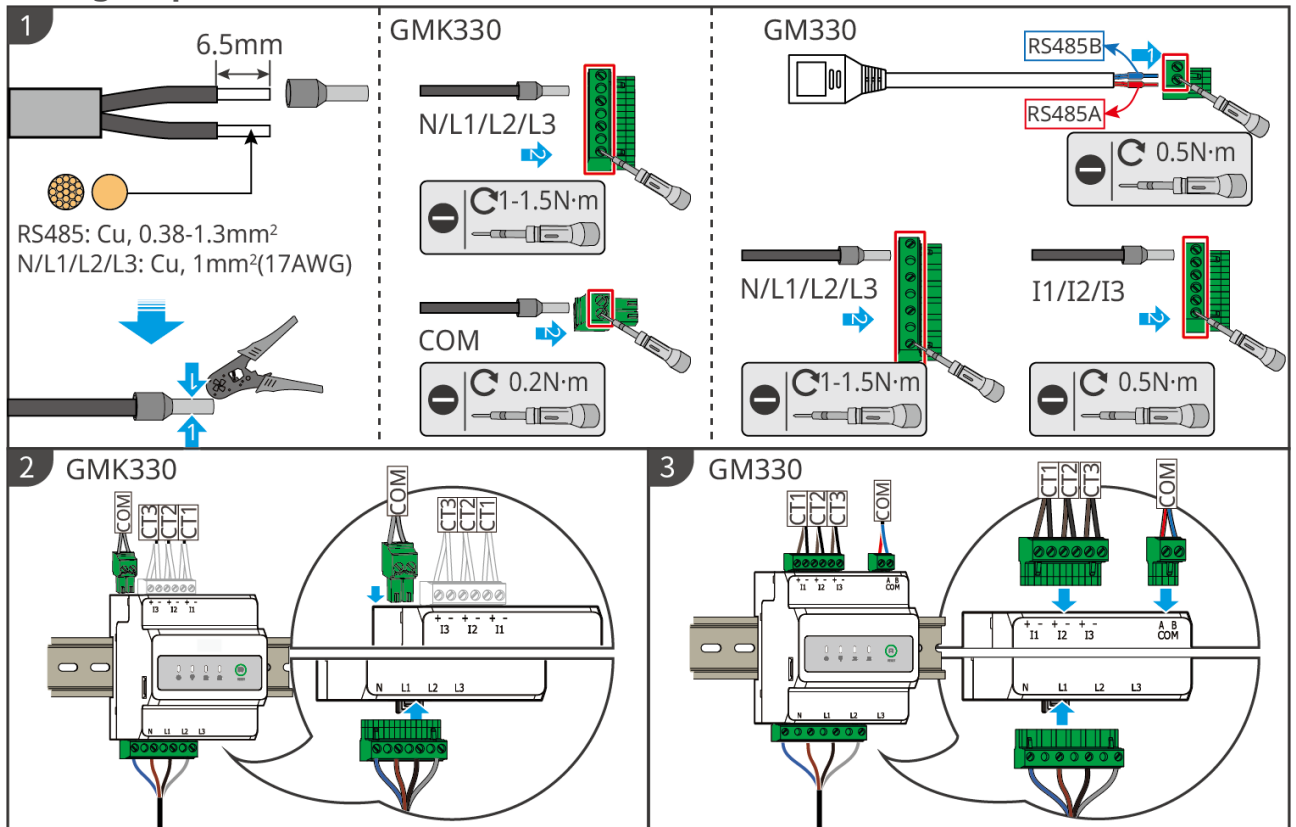

## Installing CT (Type One)

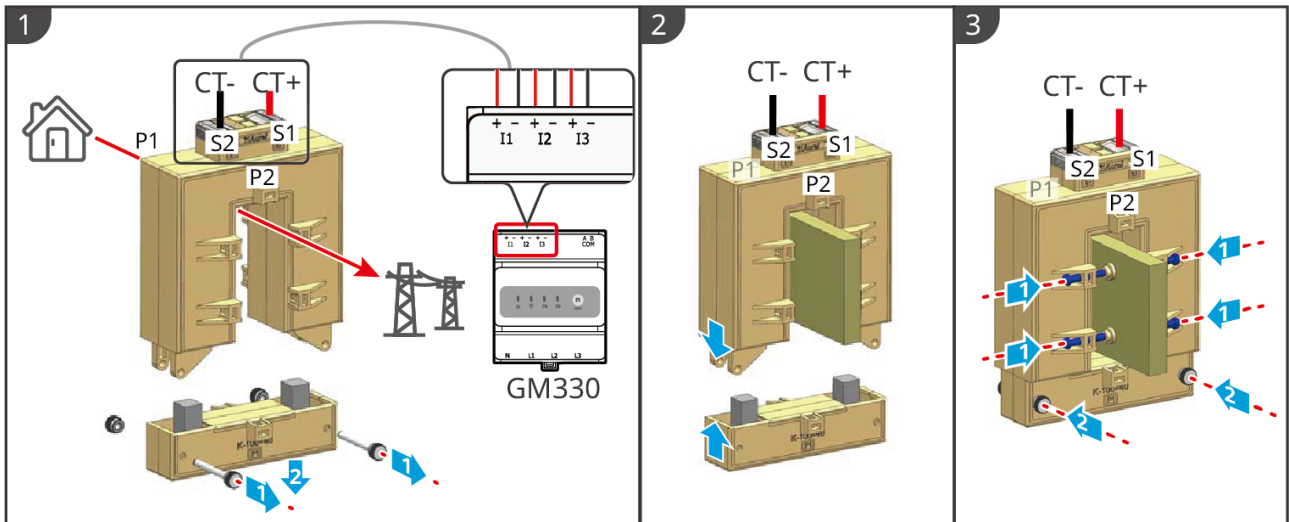

GMK10ELC0006

Installing CT (Type Two)

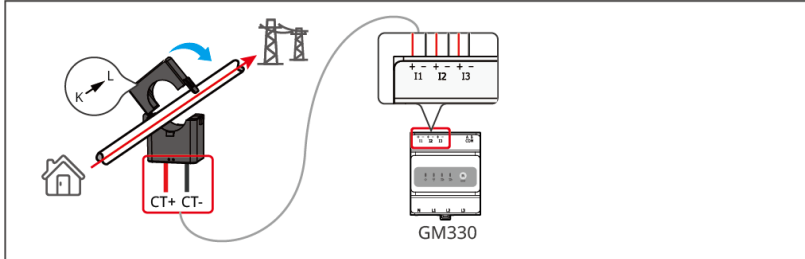

GMK10ELC0007

## 5.9 Connecting the Inverter Communication Cable

### NOTICE

- To ensure the normal use of the meter and CT, please ensure the following:
  - Ensure that the CT is connected matching the phase lines, with CT1 connected to L1, CT2 to L2, and CT3 to L3.
  - Connect according to the direction of the CT; otherwise, it may cause a CT reverse fault.
  - When replacing or maintaining the CT later, use the 'Meter/CT Auxiliary Detection Function' on the SolarGo APP to allow the Inverter to readapt to the CT sampling current direction.
- If you need to use the DRED, RCR, or remote shutdown function, after wiring is completed, please turn on this function in the SolarGo APP.
- If the Inverter is not connected to a DRED device or remote shutdown device, do not turn on this function in the SolarGo APP; otherwise, the Inverter cannot

## NOTICE

operate grid-connected.

- In a parallel system, if you need to implement the DRED and RCR functions, only connect the DRED and RCR communication lines to the master Inverter.
- The Inverter's DO signal communication port can connect dry contact signal specifications:  $\text{Max} \leq 24\text{Vdc}, 1\text{A}$ .
- The Inverter supports connecting via 4G, Bluetooth, WiFi, and LAN communication methods to a mobile phone or WEB interface to set device-related parameters, view device operation information, error information, and promptly understand the system status.
- In a single-unit system, it supports the installation of the WiFi/LAN Kit-20 or 4G Kit-CN-G20 smart communication stick.
- In a parallel system, both the master and slave Inverters need to install the WiFi/LAN Kit-20 smart communication stick for networking.
- When using the 4G Kit-CN-G20:
  - If parallel unit networking is required, contact GoodWe to purchase the WiFi/LAN Kit-20.
  - In China, it comes standard with a Micro-SIM card, and the operator is China Mobile. Please confirm that the device is installed in an area covered by the operator's signal. If local mobile signal is not covered, contact the operator to optimize the signal.
  - Supports connection to third-party monitoring platforms via the MQTT communication protocol.
- The 4G Kit-CN-G20 is an LTE single-antenna device, suitable for application scenarios with lower data transmission rate requirements.
- If you need to pair with a dual meter to achieve grid-connected generator power monitoring and load power consumption monitoring, use an RJ45 splitter for connection. The RJ45 splitter can be self-provided or contact GoodWe to purchase.
- To ensure the Inverter's waterproof rating, do not remove the waterproof plugs from unused communication ports on the Inverter.
- The Inverter communication function is optional; please select according to the actual usage scenario.

Type One

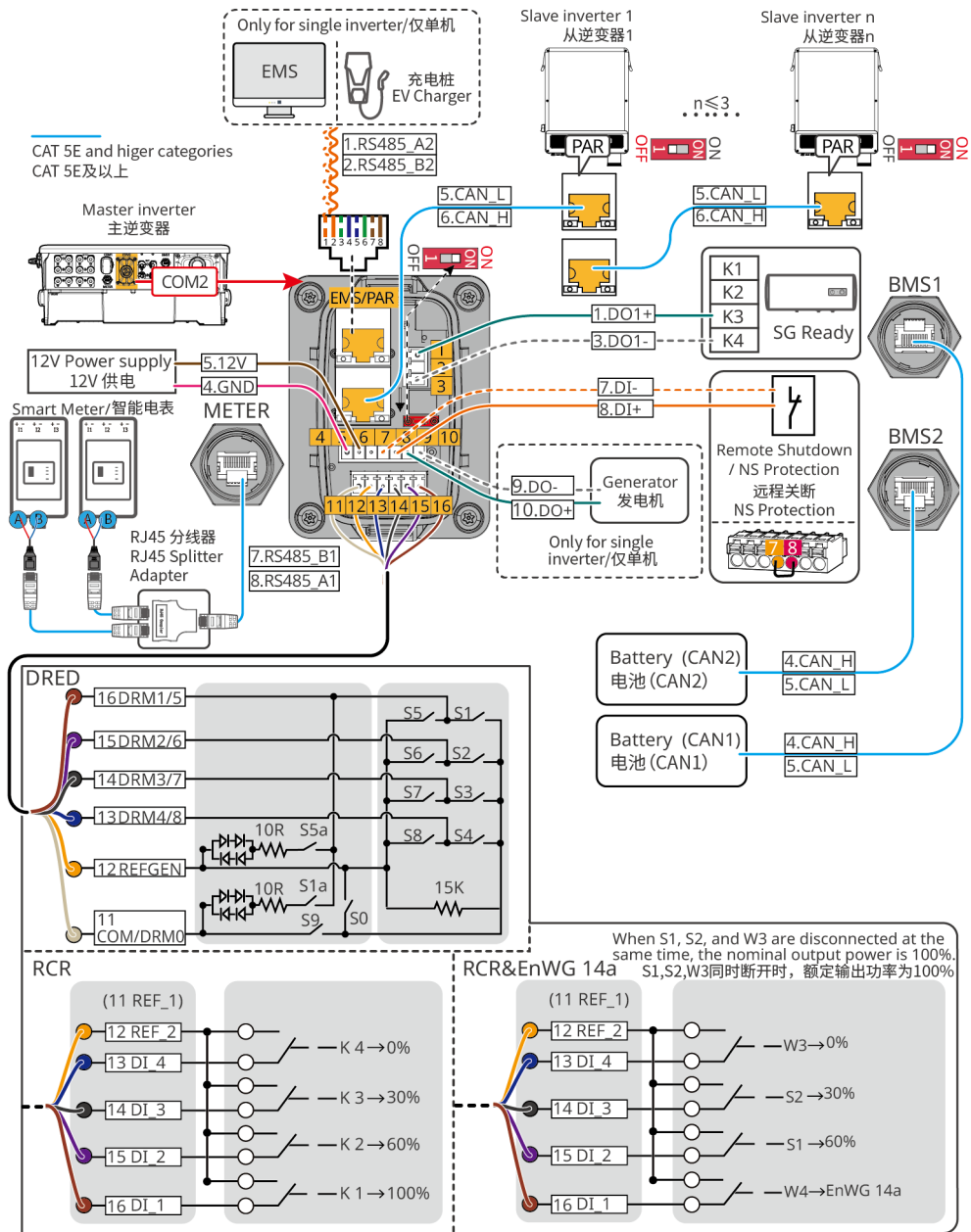

ET3010ELC0012

Type Two

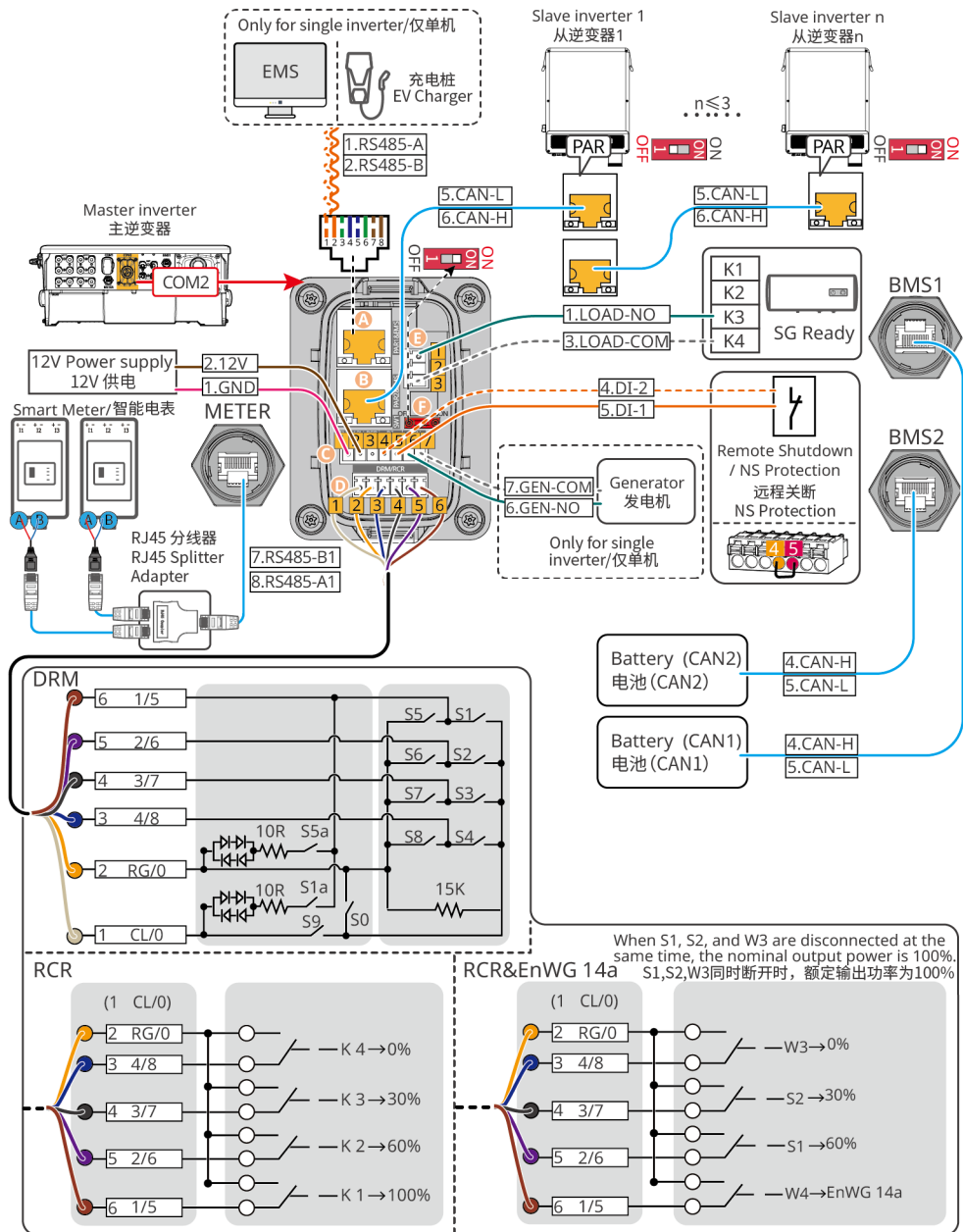

ET3010ELC0033

Silkscreen	Function	Description
DO / LOAD	load control (SG Ready)	<ul style="list-style-type: none"> <li>• Supports connection to dry contact signals to achieve functions such as load control. The DO contact capacity is 24V DC@1A, with NO/COM normally open contacts.</li> <li>• Supports SG Ready heat pump connection, controlling the heat pump via dry contact signals.</li> <li>• Supported operating modes: <ul style="list-style-type: none"> <li>◦ Operating mode 2 (Signal: 0:0 ): Energy-saving Mode. In this mode, the heat pump operates in energy-saving mode.</li> <li>◦ Operating mode 3 (Signal: 0:1 ): Activation Suggestion. In this mode, the heat pump increases hot water storage to store heat while maintaining its current operation.</li> </ul> </li> </ul>
GND 12V RSD	12V Power Supply	The inverter provides a 12V power supply port, supporting a maximum of 5W device connection. This port has short-circuit Protection Function.
DI	Remote Shutdown / NS Protection	<p>Provides a signal control port for Remote Shutdown of the device or to implement NS Protection Function.</p> <p>Remote Shutdown function:</p> <ul style="list-style-type: none"> <li>• Can control the device to stop working in case of an unexpected event.</li> <li>• The remote shutdown device must be a normally closed switch.</li> <li>• When the inverter uses the RCR or DRED function, ensure the remote shutdown device is connected, or the remote shutdown port is shorted.</li> </ul>

Silkscreen	Function	Description
DO2 / GEN	Generator Start/Stop Control Port	<ul style="list-style-type: none"> <li>• Supports connection to generator control signals only in single inverter scenarios.</li> <li>• The generator control mode is off by default, with the dry contact signal being open circuit; after the control mode is enabled, the dry contact signal becomes short circuit.</li> </ul>
DRM&RCR /	RCR, DRED, or EnWG 14a Function Connection Port	<ul style="list-style-type: none"> <li>• RCR (Ripple Control Receiver): Provides an RCR signal control port to meet grid dispatch requirements in regions like Germany.</li> <li>• DRED (Demand Response Enabling Device): Provides a DRED signal control port to meet DERD certification requirements in regions like Australia.</li> <li>• EnWG (Energy Industry Act) 14a: All controllable loads must accept emergency dimming from the grid. Grid operators can temporarily reduce the maximum grid purchase power of controllable loads to 4.2kW.</li> </ul>
EMS/PAR/PAR-1/PAR1&EMS	<ul style="list-style-type: none"> <li>• EMS Communication or EV Charger Communication Port</li> <li>• Parallel Communication Port</li> </ul>	<ul style="list-style-type: none"> <li>• CAN and BUS ports: Parallel communication ports. CAN communication is used in parallel networking to connect to other inverters; the BUS line controls the on/off-grid status of each inverter in the parallel system.</li> <li>• RS485 port: Used to connect third-party EMS devices and EV chargers. Connecting third-party EMS devices and EV chargers is not supported in parallel scenarios.</li> </ul>

<b>Silkscreen</b>	<b>Function</b>	<b>Description</b>
EMS/PAR / PAR1&EMS / PAR2&EMS	Parallel Communication Port	<ul style="list-style-type: none"> <li>• CAN and BUS ports: Parallel communication ports. CAN communication is used in parallel networking to connect to other inverters; the BUS line controls the on/off-grid status of each inverter in the parallel system.</li> </ul>
S1	Parallel DIP Switch	<p>Inverter parallel DIP switch. It is set to the ON position by default at the factory.</p> <p>In multi-unit parallel scenarios, the parallel DIP switches of the first and last inverters must be set to the ON position, while the others are set to the 1 position.</p>
METER	Smart Meter Connection Port	Connects to a smart meter to achieve functions such as output power control and load monitoring.
BMS1 / BMS2	Battery Communication Connection Port	<p>Connects to batteries using CAN communication.</p> <p>GW12KL-ET, GW15K-ET, GW20K-ET: 1 GW18KL-ET, GW25K-ET, GW29.9K-ET, GW30K-ET: 2</p>

### **Method for Connecting the Communication Cable**

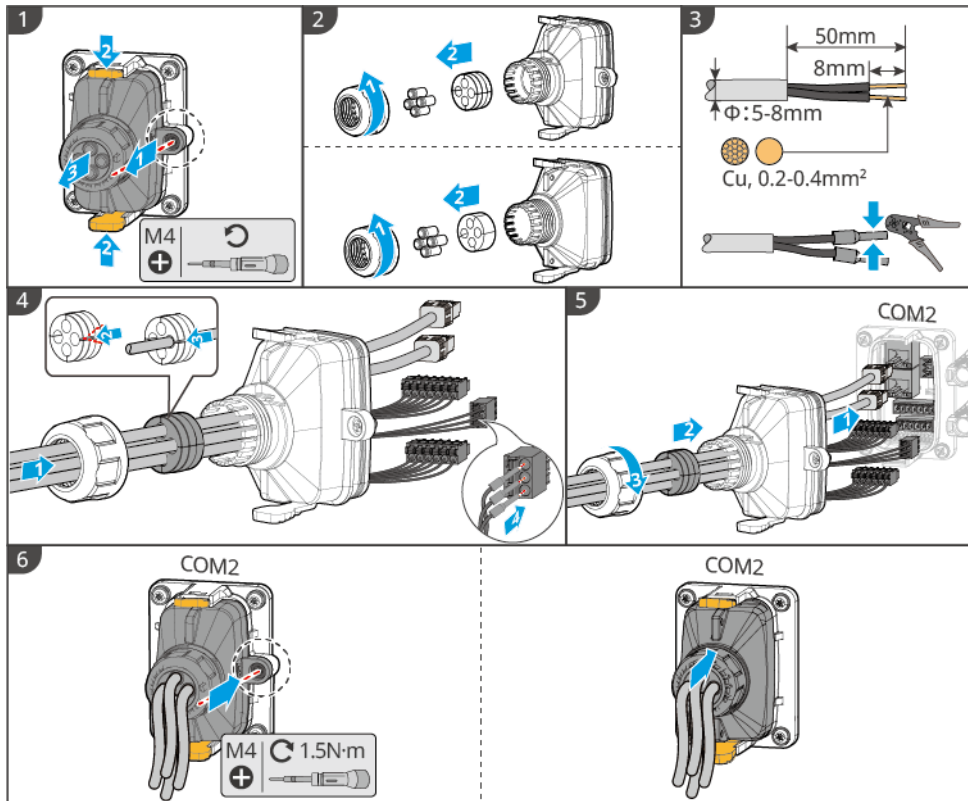

ET3010ELC0009

## 5.10 Connect the Smart Communication Stick

## NOTICE

- The inverter supports connecting to a mobile phone or WEB interface via Bluetooth, 4G, WiFi, or LAN smart dongle to set device parameters, view device operation information and error messages, and stay informed about the system status.
- When the system contains multiple inverters connected in a network, the master inverter must be installed with an Ezlink3000 smart dongle for networking.
- For an energy storage system with only one inverter, you can use a WiFi-Kit, WiFi/LAN Kit-20, or 4G smart dongle.
- When using the WiFi communication method to connect the inverter to a router, you can install a WiFi-Kit, WiFi/LAN Kit-20, or Ezlink3000 smart dongle.
- When using the LAN communication method to connect the inverter to a router, you can install a WiFi/LAN Kit-20 or Ezlink3000 smart dongle.
- When using the 4G communication method to upload the energy storage system operation information to the monitoring platform, you can install an LS4G Kit-CN, 4G Kit-CN, 4G Kit-CN-G20, or 4G Kit-CN-G21 smart dongle. When using LS4G Kit-CN or 4G Kit-CN, you need to use the smart dongle shipped with the inverter to configure the parameters of the energy storage system. After configuration is complete, replace it with the LS4G Kit-CN or 4G Kit-CN for data transmission. When using 4G Kit-CN-G20 or 4G Kit-CN-G21, please use the Bluetooth signal emitted by the module for local device configuration.
- The 4G module is an LTE single-antenna device, suitable for application scenarios with lower data transmission rate requirements.
- The built-in SIM card in the 4G module is a China Mobile communication card. Please confirm whether the device is installed in an area covered by China Mobile's 4G signal.
- After installing the 4G Kit-CN-G20 or 4G Kit-CN-G21 smart dongle, please contact the after-sales service center to bind the inverter and the smart dongle. After binding, if you need to install the smart dongle on another inverter, please contact the after-sales service center to unbind it first.
- To ensure 4G signal communication quality, do not install the device indoors or in areas with metal interference signals.

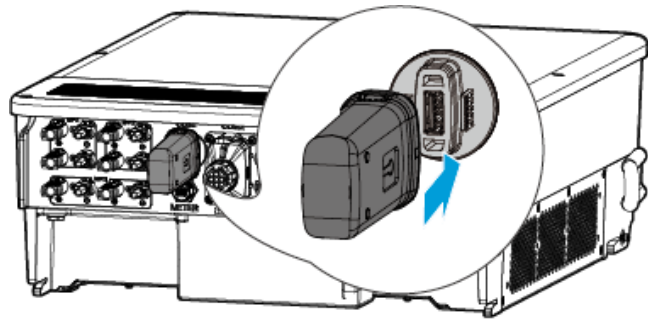

ET3010ELC0034

# 6 System Commissioning

## 6.1 Check Before Power ON

No.	Inspection Item
1	The equipment is securely installed, the installation location facilitates operation and maintenance, the installation space allows for ventilation and heat dissipation, and the installation environment is clean and tidy.
2	The PE cable, DC cable, AC cable, Communication cable, and terminal resistor are connected correctly and securely.
3	Cable bundling meets wiring requirements, is reasonably distributed, and shows no damage.
4	For unused cable entry holes and ports, ensure they are reliably connected using the terminal blocks provided with the accessories and have been sealed.
5	Ensure that used cable entry holes have been sealed.
6	The voltage and frequency at the inverter grid connection point meet the grid connection requirements.

## 6.2 Power ON

### WARNING

- When multiple inverters are connected in parallel, ensure that all slave inverters are powered on at the AC side within one minute after the master inverter is powered on at the AC side.
- When multiple battery systems are connected in parallel, ensure that the QF2 switches of all battery systems are closed within five minutes.  
When multiple battery systems are connected in parallel, before closing QF1, ensure that the SolarGo App correctly displays the number of parallel battery systems, otherwise it may cause damage to the battery systems.

## NOTICE

When there is no PV power generation in the photovoltaic system and the grid is abnormal, if the inverter cannot work normally, the battery black start function can be used to force the battery to discharge and start the inverter. The inverter can enter off-grid mode and supply power to the load from the battery.

- BAT series 92.1-112.6kWh commercial and industrial battery system black start process refers to the power on/off steps.
- The black start process for other batteries is the same as the power-on steps.

BAT series 92.1-112.6kWh commercial and industrial battery system: Before power-on operation, ensure that the battery's emergency stop switch is in the released state. Release step: Rotate the emergency stop switch to the right.



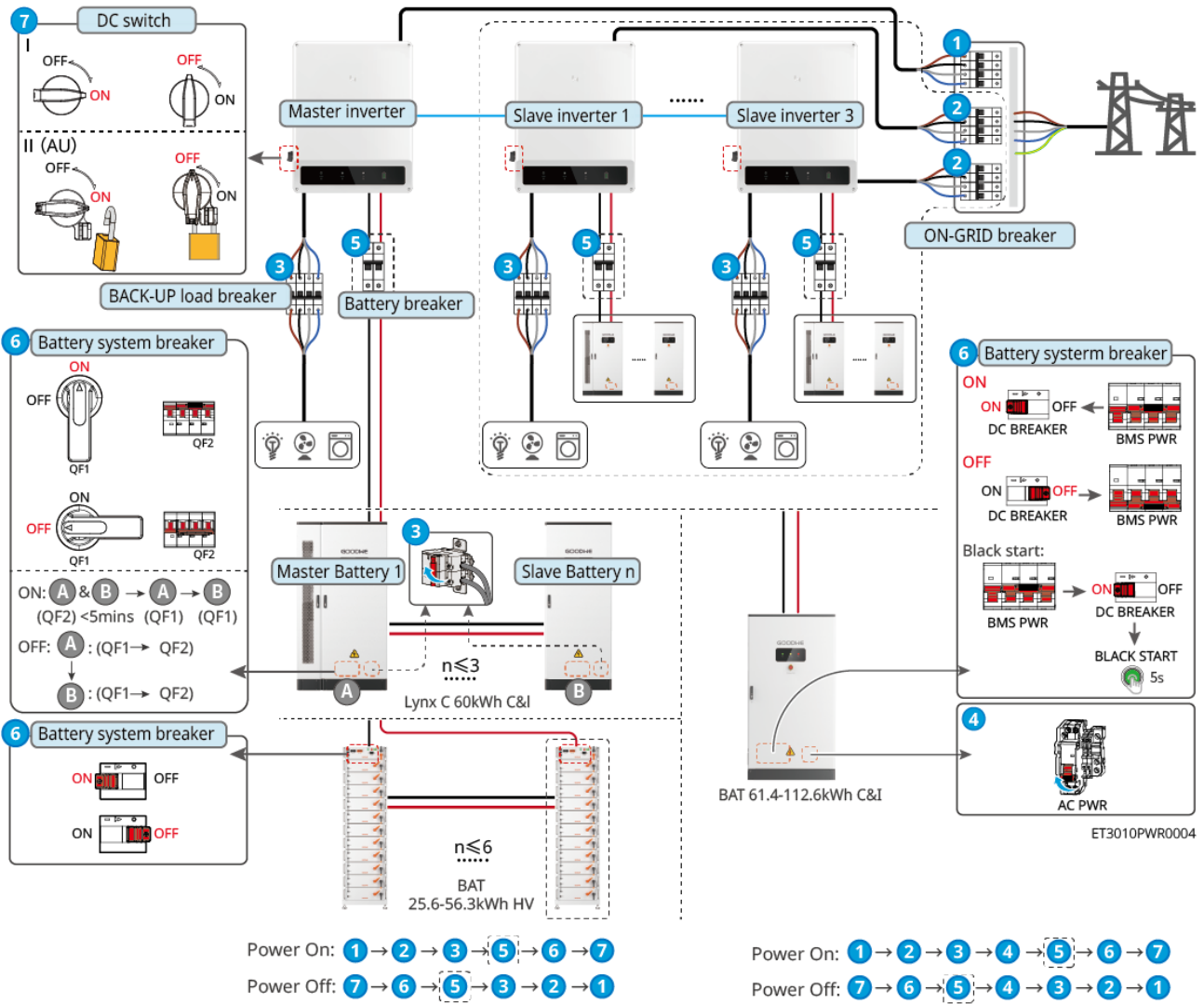







⑤: Optional according to local laws and regulations.

## 6.3 Indicators

### 6.3.1 Inverter Indicators

indicator	Status	Description
		The inverter is powered on and in standby mode
		The inverter is starting up and in self-test mode
		The inverter is operating normally in grid-tied power generation or off-grid mode
		BACK-UP output overload
		System fault

indicator	Status	Description
		The inverter is powered off
		Grid abnormal, the inverter BACK-UP port power supply is normal
		Grid normal, the inverter BACK-UP port power supply is normal
		BACK-UP port has no power supply
		Inverter monitoring module resetting
		No connection established between the inverter and communication terminal
		Communication fault between the communication terminal and cloud server
		Inverter monitoring normal
		Inverter monitoring module not started

### 6.3.2 Battery Indicators

- Lynx C Series 60kWh Commercial & Industrial Battery System



**Run**







**Warning**



**Fault**

LXC10010DSC0002

indicator	Status	Description
 Run		Green light steady: Device operating normally
		Green light single flash: Battery operating normally, not communicating with inverter
		Green light double flash: Device in standby
		Green light off, yellow light steady: Device warning Green light off, steady red: Device fault Green, yellow, and red lights all off: Device not powered on
		Steady: Device warning

indicator	Status	Description
 Warning		Off: No device warning
 Fault		Steady: Device fault
		Off: No device fault

• **BAT-S Series 25.6-56.3kWh High Voltage Battery**











**RUN**



**FAULT**

BAT10DSC0003

Indicator	Status	Description
 RUN		Green light solid: Device operating normally
		Green light single blink: Battery operating normally, not communicating with inverter
		Green light double blink: Device in standby
 FAULT		Solid light: Device fault
		Red light single blink: System undervoltage level 3~4
		Red light double blink: SN abnormal

• **BAT-C Series 61.4-112.6kWh Commercial & Industrial Battery System**



**Run**















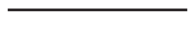

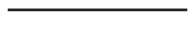
**Warning**





**Fault**

LXC10010DSC0002

Indicator	Status	Description
 Run		Steady green: Device operating normally
		Green blinks once: Battery operating normally, not communicating with the inverter
		Green blinks twice: Device in standby
		Green off, steady yellow: Device warning
 Warning		Green off, Steady red: Device fault
		Green, yellow, and red all off: Device not powered on
 Fault		Steady on: Device warning
		Off: No device warning
		Steady on: Device fault
 Fault		Off: No device fault
		Red single flash: Sleep (under-voltage)



### 6.3.3 Smart Meter Indicator

#### GM330&GMK330

Type	Status	Description
Power Light 	Steady on	Meter is powered on, no RS485 communication
	Blinking	Meter is powered on, RS485 communication normal
	Off	Meter is powered off
Communication Light 	Off	Reserved
	Blinking	Press and hold the Reset button for $\geq 5s$ , Power Light and Buy/Sell Light blink: Meter reset
Buy/Sell Light 	Steady on	buy power from the grid
	Blinking	Sell power to the grid
	Off	Not buying or selling power

Type	Status	Description
	Reserved	

### GM3000

Type	Status	Description
Power Light 	Steady on	The meter is powered on
	Off	The meter is powered off
Buy/Sell Light 	Steady on	buy power from the grid
	Flashing	Selling power to the grid
Communication Light 	Flashing	Normal communication
	Flashing 5 times continuously	<ul style="list-style-type: none"> <li>Press the Reset button for &lt;3s: Meter reset</li> <li>Press the Reset button for 5s: Meter parameters restored to factory settings</li> <li>Press the Reset button for &gt;10s: Meter parameters restored to factory settings, energy data cleared</li> </ul>
	Off	No communication from the meter

### 6.3.4 Smart Dongle Indicator









- **Wi-Fi Kit**

indicator	Color	Status	Description
Power indicator 	Green	On	Wi-Fi Kit is powered on.
		Off	Wi-Fi Kit is not powered on or is restarting.
	Blue	On	WiFi AP hotspot has been connected.

Commu nication indicato r  		Off	<ul style="list-style-type: none"> <li>• Wi-Fi Kit communication is abnormal.</li> <li>• Wi-Fi Kit is restarting.</li> </ul>
---	--	-----	--

• WiFi/LAN Kit-20

NOTICE	
<ul style="list-style-type: none"> <li>• After double-clicking the Reload button to turn on Bluetooth, the communication indicator light switches to a single blink state. Please connect to the SolarGo APP within 5 minutes, otherwise Bluetooth will automatically turn off.</li> <li>• The single blink state of the communication indicator light only appears after double-clicking the Reload button to turn on Bluetooth.</li> </ul>	





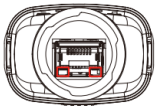

Indicat or	Status	Description
Power indicato r  		Steady on: The Smart Communication Stick is powered on.
		Off: The Smart Communication Stick is not powered on.
Commu nication indicato r  		Steady on: WiFi mode or LAN mode communication is normal.
		Single blink: The Smart Communication Stick's Bluetooth signal is on, waiting to connect to the SolarGo app.
		Two blinks: The Smart Communication Stick failed to connect to the router.
		Four blinks: The Smart Communication Stick communicates normally with the router but failed to connect to the server.
		Six blinks: The Smart Communication Stick is identifying connected devices.



Indicator	Status	Description
		Off: The Smart Communication Stick is undergoing a software reset or is not powered on.

Indicator	Color	State	Description
LAN Port Communication Indicator 	Green	Constantly lit	100Mbps wired network connection is normal.
		Off	<ul style="list-style-type: none"> <li>Network cable is not connected.</li> <li>100Mbps wired network connection is abnormal.</li> <li>10Mbps wired network connection is normal.</li> </ul>
	Yellow	Constantly lit	10/100Mbps wired network connection is normal, with no communication data being transmitted or received.
		Flashing	Communication data is being transmitted or received.
		Off	Network cable is not connected.

Button	Description
Reload	Hold for 0.5~3 seconds to reset the Smart Communication Stick.
	Hold for 6~20 seconds to restore the Smart Communication Stick to factory settings.
	Double-click quickly to enable Bluetooth signal (only lasts for 5 minutes).



• 4G Kit-CN-G20 & 4G Kit-CN-G21

Indicator	Status	Description
		Steady on: The smart communication stick is powered on.
		Off: The smart communication stick is not powered.
		Steady on: The smart communication stick is connected to the server, communication is normal.
		Double flash: The smart communication stick is not connected to the communication base station.

Indicator	Status	Description
		Quadruple flash: The smart communication stick is connected to the communication base station but not to the server.
		Sextuple flash: Communication between the smart communication stick and the inverter is disconnected.
		Off: The smart communication stick is undergoing software reset or is not powered.







Button	Description
RELOAD	Hold for 0.5~3 seconds to restart the Smart Communication Stick.
	Hold for 6~20 seconds to restore the Smart Communication Stick to factory settings.

• **LS4G Kit-CN、4G Kit-CN**

indicator	Color	Status	Description
Power indicator 	Green	On	Module is secured and powered on
		Off	Module is not secured or not powered on
Communi cation indicator 	Blue	slow blinking (0.2 on, 1.8s off)	<ul style="list-style-type: none"> <li>• Inverter communication light blinks 2 times: Dialing, searching for network status</li> <li>• Inverter communication light blinks 4 times: Connection to cloud failed due to no data traffic</li> </ul>
		slow blinking (1.8s on, 0.2s off)	<ul style="list-style-type: none"> <li>• Inverter communication light blinks 2 times: Dialing successful</li> <li>• Inverter communication light is constantly on: Cloud connection successful</li> <li>• Inverter communication light blinks 4 times: Connection to cloud failed due to no data traffic</li> </ul>

		fast blinking (0.125s on, 0.125s off)	Inverter is communicating with the cloud via the module
		0.2s on, 8s off	SIM card not installed or SIM card poor contact

- **Ezlink3000**

indicator/silk screen	Color	Status	Description
Power indicator 	Blue		Flashing: The communication stick is operating normally.
			Off: The communication stick is powered off.
Communication indicator 	Green		Steady on: The communication stick is connected to the server.
			Double flash: The communication stick is not connected to the router.
			Quadruple flash: The communication stick is connected to the router but not to the server.
RELOAD	-	-	Press briefly for 1-3 seconds to restart the communication stick. Press and hold for 6-10 seconds to restore factory settings. Double-click quickly to enable Bluetooth signal (only lasts for 5 minutes).

## 6.4 Close Cabinet Door

- **Lynx C Series 60kWh Commercial & Industrial Battery System**

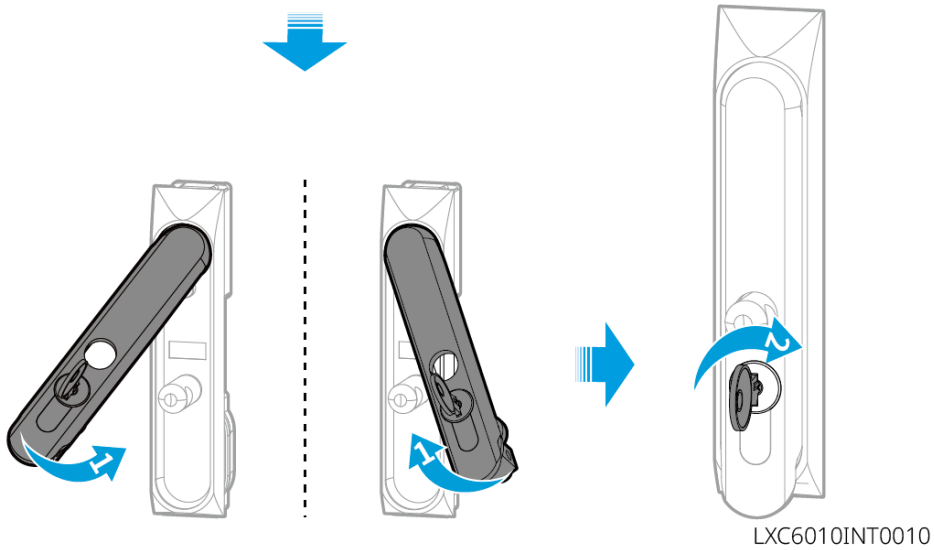
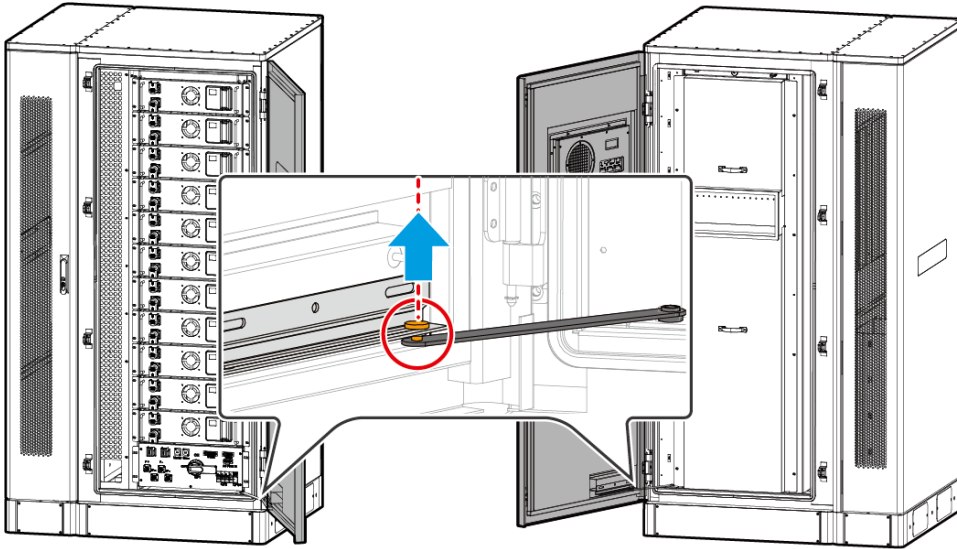

• **BATSeries 61.4-112.6kWh Commercial & Industrial Battery System**

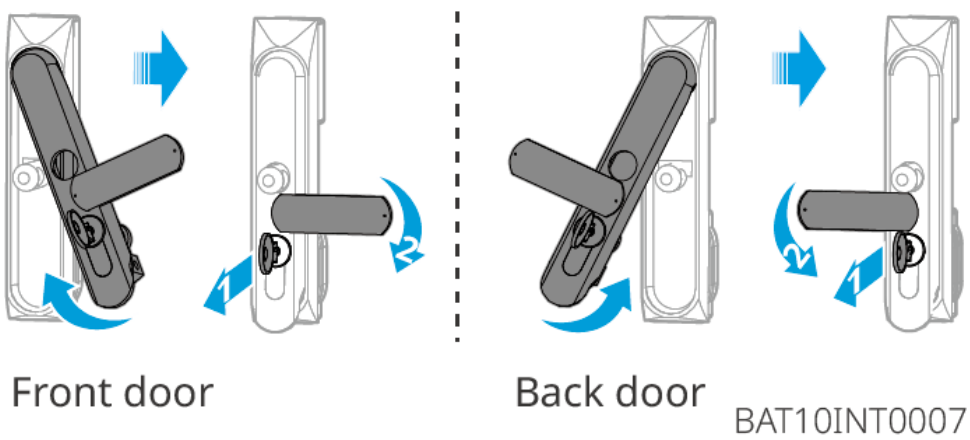

# 7 System Commissioning

## 7.1 SolarGo APP

### 7.1.1 Product Introduction

#### NOTICE

- All the user interface (UI) screenshots or words in this document are based on **SolarGo app V6.6.0**. The UI may be different due to the version upgrade. The screenshots, words or data are for reference only.
- The method to set parameters is the same for all inverters. But the parameters displayed varies based on the equipment model and safety code. Refer to the actual interface display for specific parameters.
- Before setting any parameters, read through user manual of the App and the inverter or charger to learn the product functions and features. When the inverter parameters are set improperly, the inverter may fail to connect to the utility grid or fail to connect to the utility grid in compliance with related requirements and damage the battery, which will affect the inverter's power generation.

SolarGo App is a mobile application that communicates with the inverter via Bluetooth, WiFi, 4G, or GPRS. Commonly used functions are as follows:

- Check the operating data, software version, alarms of the inverter, etc.
- Set grid parameters and communication parameters of the inverter.
- Set charging mode of the charger.
- Maintain the equipment.

#### 7.1.1.1 Downloading and Installing the App

Make sure that the mobile phone meets the following requirements:

- Mobile phone operating system: Android 5.0 or later, iOS 13.0 or later.
- The mobile phone can access the Internet.

- The mobile phone supports WLAN or Bluetooth.

### NOTICE

After installing the app, it can automatically prompt users to update the app version.

Method 1: Search SolarGo in Google Play (Android) or App Store (iOS) to download and install the app.

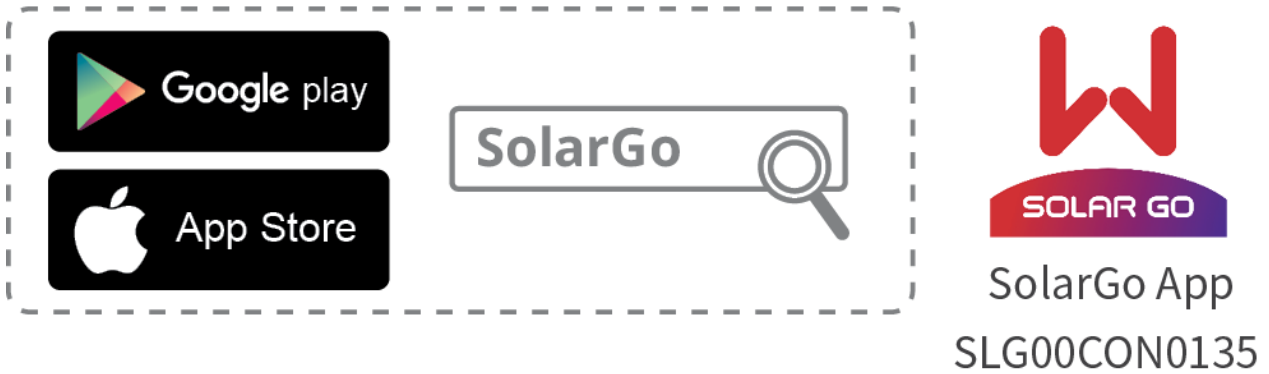

Method 2: Scan the QR code below to download and install the app.

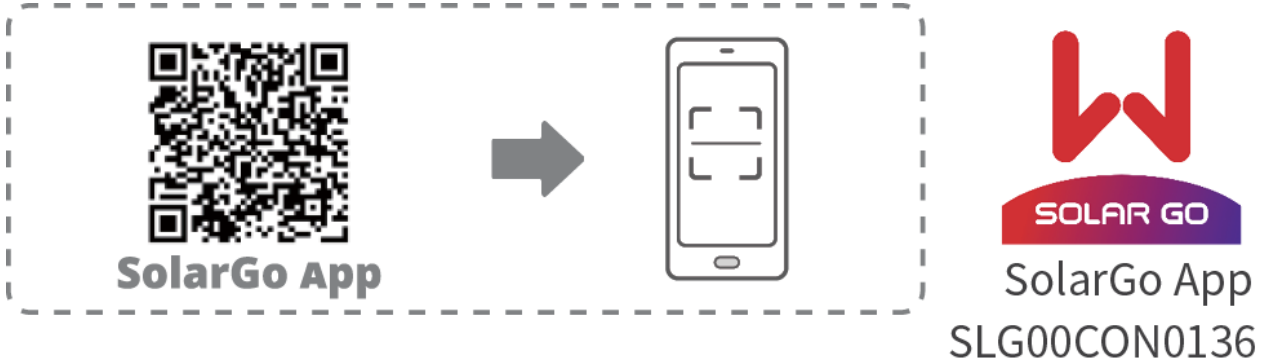

#### 7.1.1.2 App Connection

Connect as the following shows after powering on the equipment.

### NOTICE

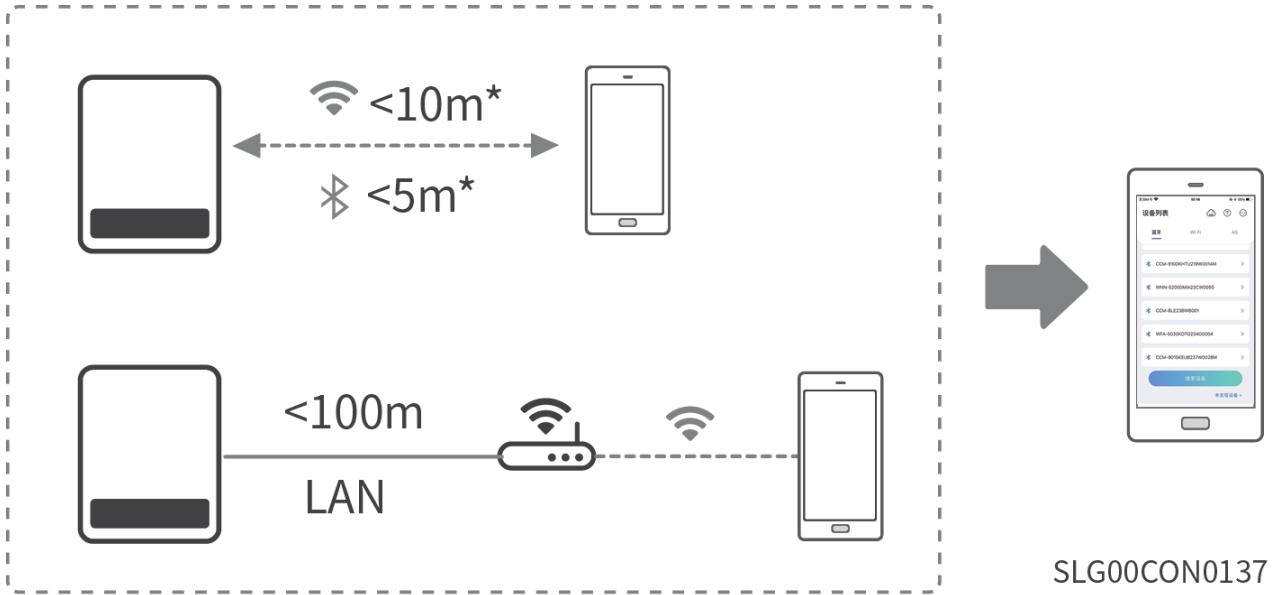

The connection distance varies depending on smart dongles. Refer to the actual used smart dongles.

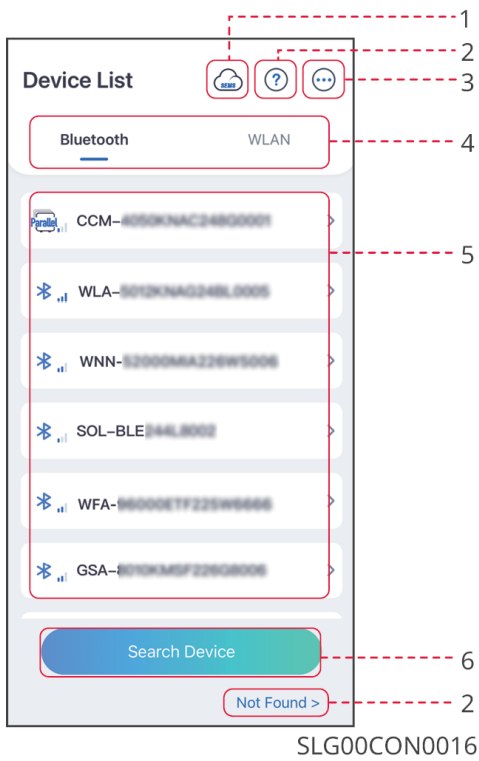

### 7.1.1.3 GUI Introductions to Login Page



No.	Name/Icon	Description
1		Tap the icon to open the page downloading the SEMS Portal app.

No.	Name/Icon	Description
2		Tap to read the connection guide.
	Not found	
3		<ul style="list-style-type: none"> <li>• Check information such as app version, local contacts, etc.</li> <li>• Other settings, such as update date, switch language, set temperature unit, etc.</li> </ul>
4	Bluetooth/Wi-Fi/4G	Select based on actual communication method. If you have any problems, tap  or <b>NOT Found</b> to read the connection guides.
5	Device List	<ul style="list-style-type: none"> <li>• The list of all devices. The last digits of the device name are normally the serial number of the device.</li> <li>• Select the device by checking the serial number of the master inverter when multi inverters are parallel connected.</li> <li>• The device name varies depending on the inverter model or smart dongle model: <ul style="list-style-type: none"> <li>◦ Wi-Fi/LAN Kit, Wi-Fi Kit, Wi-Fi Box: Solar-WiFi***</li> <li>◦ External or integrated bluetooth module: Solar-BLE***</li> <li>◦ WiFi/LAN Kit-20: WLA-***</li> <li>◦ WiFi Kit-20: WFA-***</li> <li>◦ Ezlink3000: CCM-BLE***; CCM-***; ***</li> <li>◦ 4G Kit-CN-G20/4G Kit-CN-G21: GSA-***; GSB-***</li> <li>◦ 4G Kit-G20: GSC-***</li> <li>◦ Micro inverter: WNN***</li> <li>◦ AC Charger: ***</li> </ul> </li> </ul>
6	Search Device	Tap <b>Search Device</b> if the device is not found.

## 7.1.2 Connecting the Hybrid Inverter (Bluetooth)

**Step 1** Ensure that the inverter is power on, both the inverter and the communication module are working properly.

**Step 2** Select **Bluetooth** tab on the SolarGo app homepage.

**Step 3** Pull down or tap **Search Device** to refresh the device list. Find the device by the the inverter serial number. Tap the device name to log into the **Home** page. Select the device by checking the serial number of the master inverter when multi inverters are parallel connected.

**Step 4** For first connection with the equipment via Bluetooth, there will be a Bluetooth pairing prompt, tap **Pair** to continue the connection.

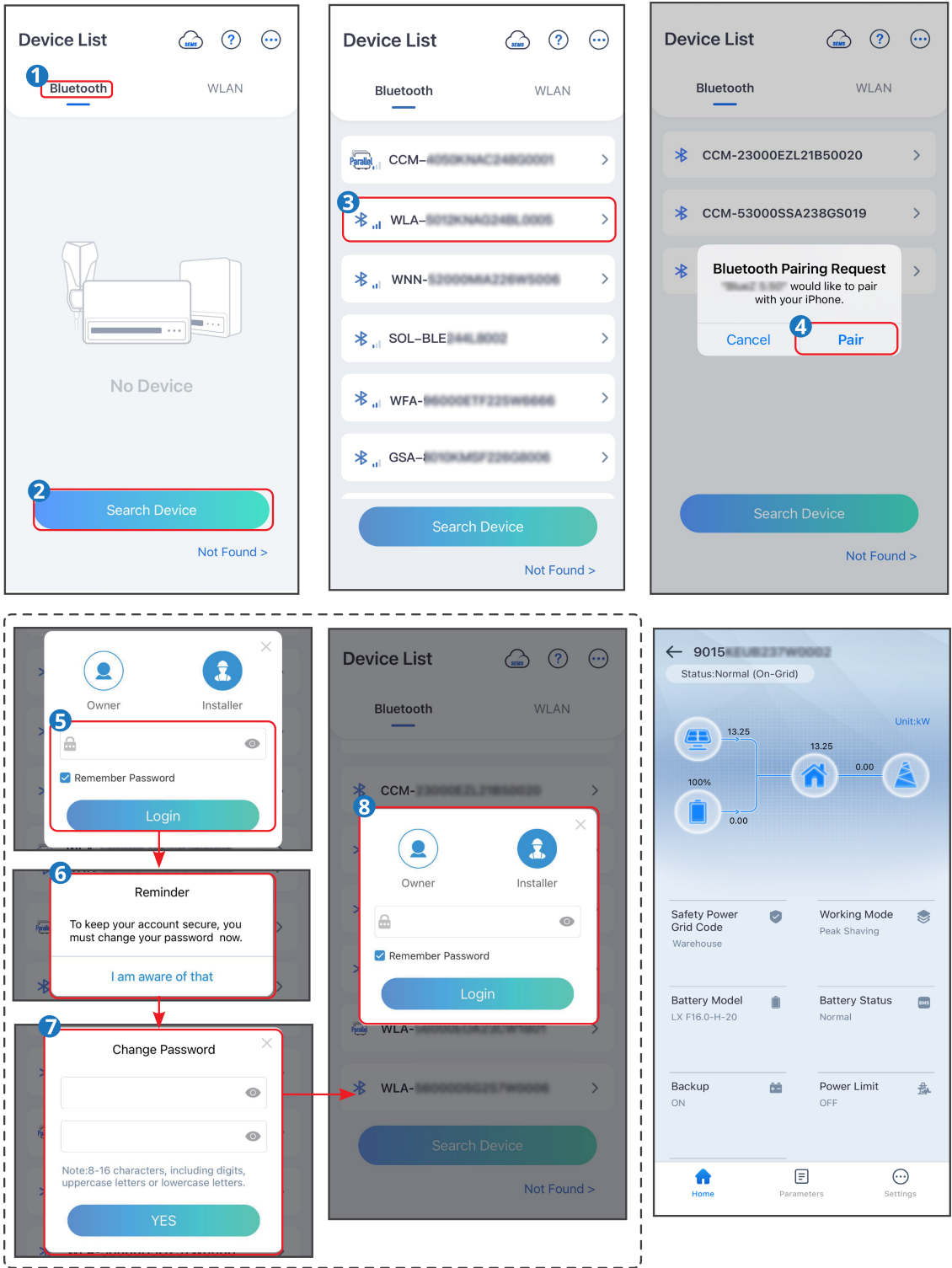

**Step 5** Log in as an Owner or an Installer. Initial password: 1234. Default password: 1234.

**Step 6** (Optional): If connecting via WLA-\*\*\* or WFA-\*\*\*, enable Bluetooth Stays On following the prompts as entering the device details page. Otherwise, the bluetooth signal of the device will be off after disconnection.

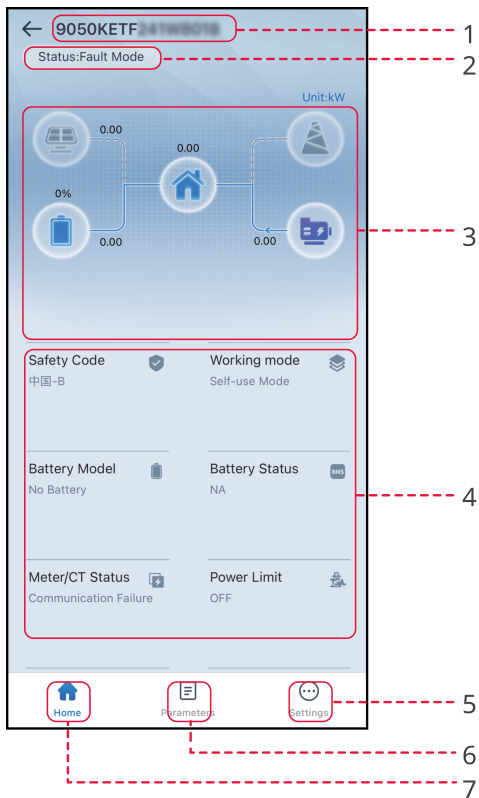

### 7.1.3 GUI Introductions to Hybrid Inverters



No.	Name/Icon	Description
1	Serial Number	Serial number of the connected inverter.
2	Device Status	Indicates the status of the inverter, such as Working, Fault, etc.
3	Energy Flow Chart	Indicates the energy flow chart of the PV system. The actual page prevails.
4	System Status	Indicates the system status, such as Safety Code, Working Mode, Battery Model, Battery Status, Power Limit, Three-Phase Unbalanced Output, etc..
5		Home. Tap Home to check Serial Number, Device Status, Energy Flow Chart, System Status, etc.
6		Parameters. Tap Parameters to check the inverter Data.

No.	Name/Icon	Description
7		<ul style="list-style-type: none"> <li>• Settings Tap to perform quick settings, basic settings, advanced settings, etc. on the inverter.</li> <li>• Login required to access Quick Setup and Advanced Setting. Contact the supplier or after sales service for password. Password for professional technicians only.</li> </ul>

## 7.1.4 Setting Communication Parameters

### NOTICE

The communication configuration interface may be different if the inverter uses different communication modes or connects different communication modules. Please refer to the actual interface.

### 7.1.4.1 Setting Privacy and Security Parameters

#### Type I

**Step 1** : Tap **Home** > **Settings** > **Communication Setting** > **Privacy & Security** to set the parameters.

**Step 2** : Set the new password for the WiFi hotspot of the communication module, and tap **Save**.

**Step 3** Open the WiFi settings of your phone and connect to the inverter's WiFi signal (Solar WiFi\*\*\*) with the new password.

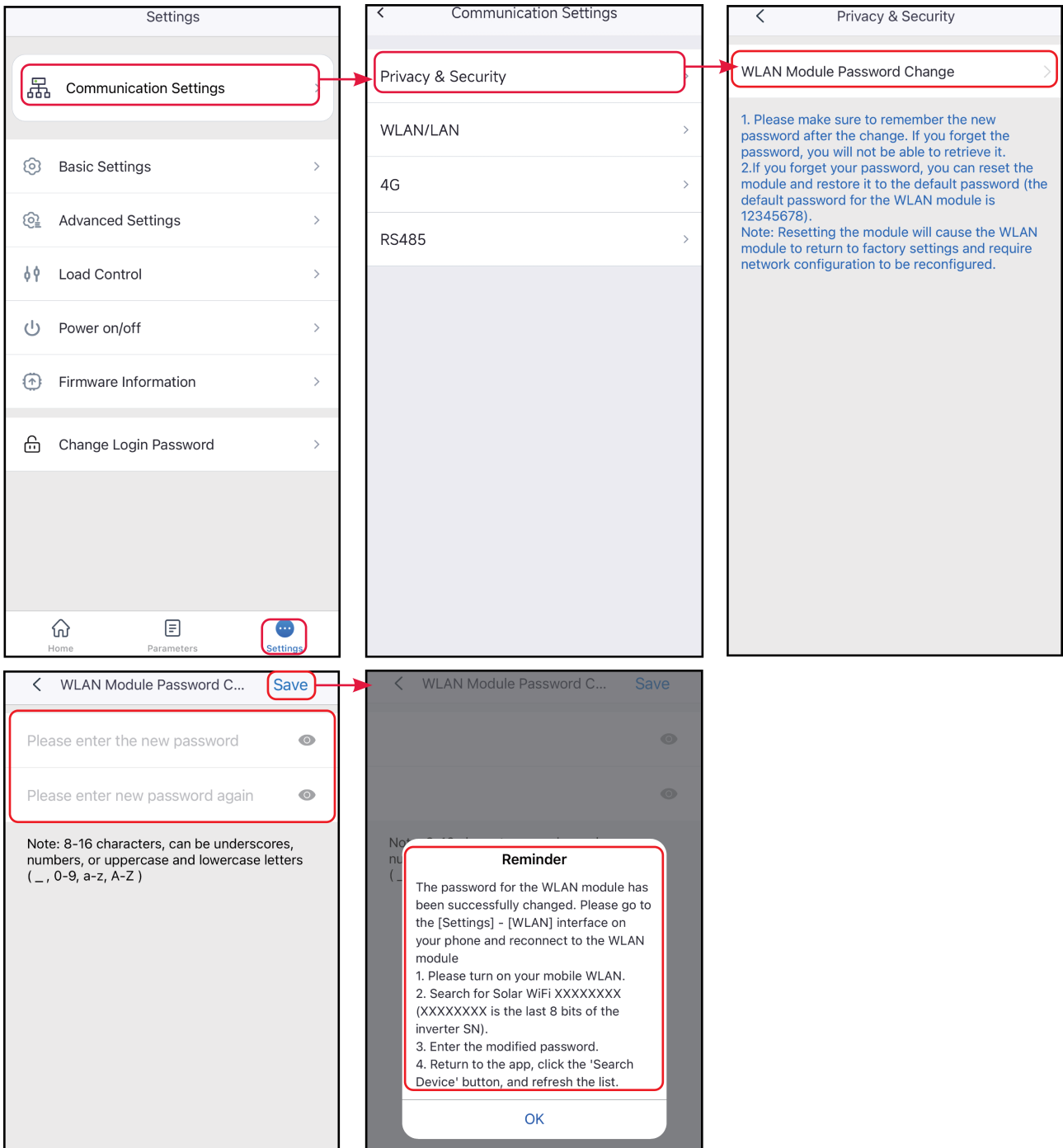

## Type II

**Step 1 :** Tap **Home > Settings > Communication Setting > Privacy & Security** to set the parameters.

**Step 2** Enable Bluetooth Stays On or WLAN Control based on actual needs.

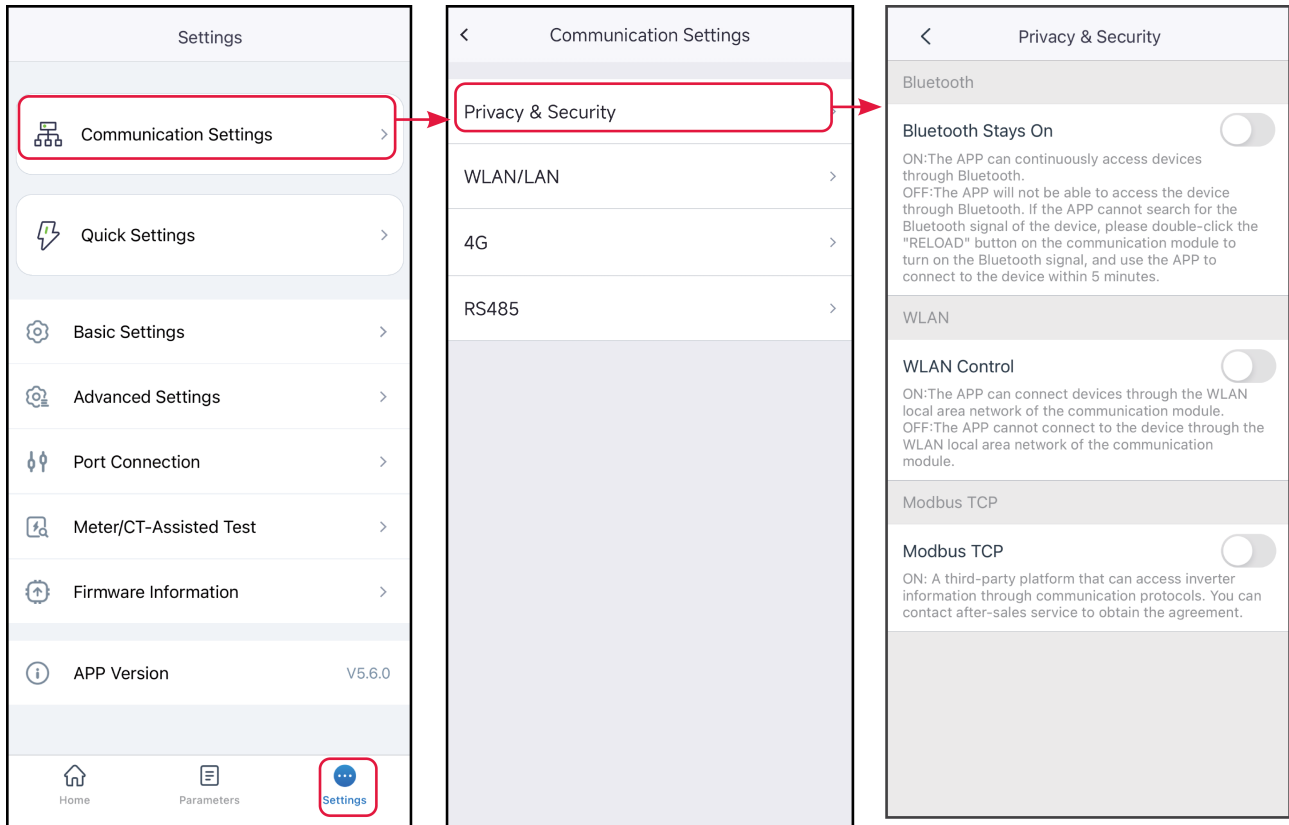

No.	Parameters	Description
1	Bluetooth Stays On	Disabled by default. Enable the function, the bluetooth of the device will be contentious on to keep connected to SolarGo. Otherwise, the bluetooth will be off in 5 minutes, and the device will be disconnected from SolarGo.
2	WLAN Control	Disabled by default. Enable the function, the device and the SolarGo can be connected through the WLAN when they are on the same LAN. Otherwise, they cannot be connected even if they are on the same LAN.
3	Modbus-TCP	Enable the function, the third party monitoring platform can access inverter through Modbus-TCP communication protocol.
4	SSH control Ezlink	After enabling this function, third-party platforms can connect to and control EzLink's Linux system.

### Type III

**Step 1 :** Tap **Home > Settings > Communication Setting > Privacy & Security** to set

the parameters.

**Step 2 : Enable Bluetooth Stays On or Login Password based on actual needs.**

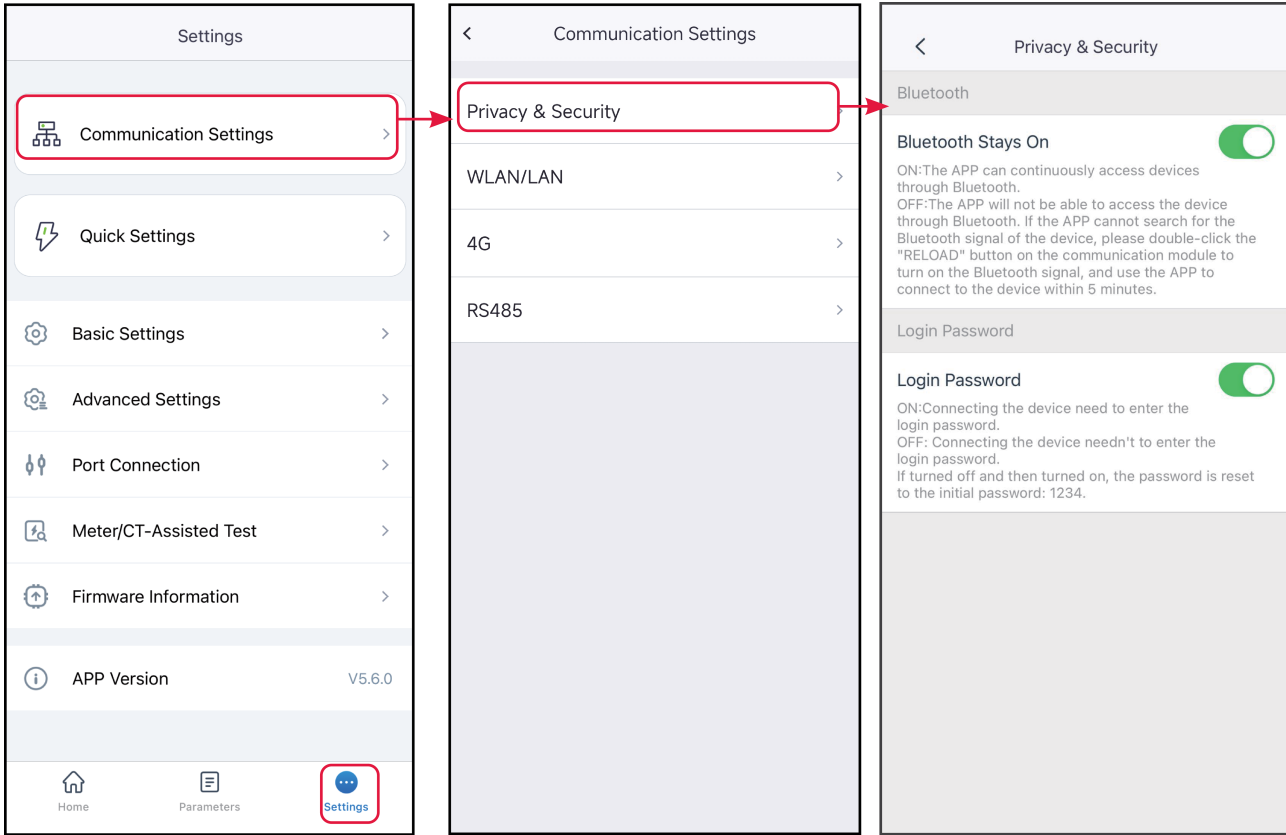

No.	Parameters	Description
1	Bluetooth Stays On	Disabled by default. Enable the function, the bluetooth of the device will be contentious on to keep connected to SolarGo. Otherwise, the bluetooth will be off in 5 minutes, and the device will be disconnected from SolarGo.
2	Password	Disabled by default. Enable the function, you will be prompted to enter the login password when connecting the device to SolarGo. Use the initial password and change it at the first login prompt.

**7.1.4.2 Setting WLAN/LAN Parameters**

## NOTICE

When the inverter is connected to different communication modules, the communication configuration interface may be different. Please refer to the actual interface.

**Step 1 :** Tap **Home > Settings > Communication Setting > WLAN/LAN** to set the parameters.

**Step 2 :** Configure the WLAN or LAN parameters based on actual needs.

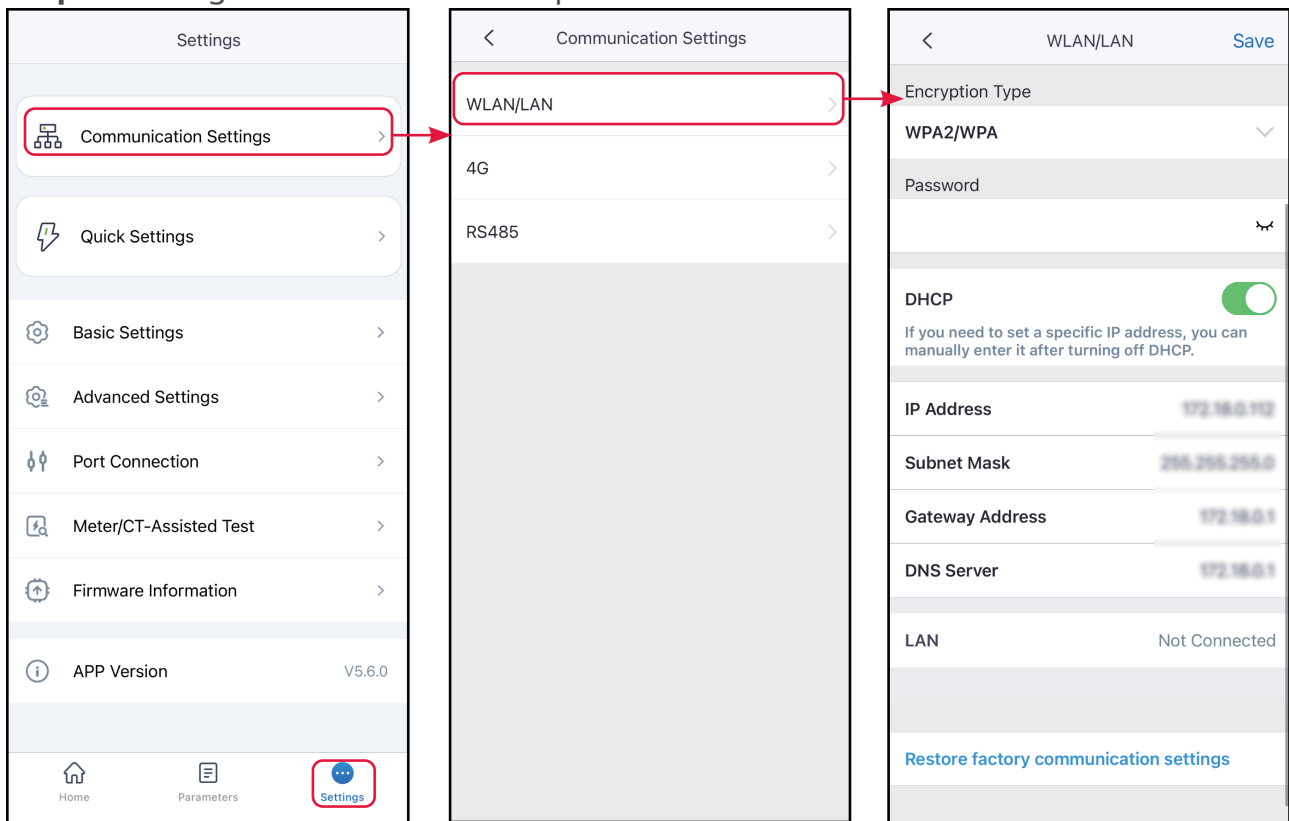

No.	Parameters	Description
1	Network Name	Only for WLAN. Select WiFi based on the actual connecting.
2	Password	Only for WLAN. WiFi password for the actual connected network.
3	DHCP	Enable DHCP when the router is in dynamic IP mode. Disable DHCP when a switch is used or the router is in static IP mode.

No.	Parameters	Description
4	IP Address	Do not configure the parameters when DHCP is enabled. Configure the parameters according to the router or switch information when DHCP is disabled.
5	Subnet Mask	
6	Gateway Address	
7	DNS Server	

### 7.1.4.3 Configuring RS485 Parameters

#### NOTICE

Set the communication address of the inverter. For a single inverter, the address is set based on actual needs. For multi connected inverters, the address of each inverter should be different while cannot be 247.

**Step 1:** Tap **Home > Settings > Communication Settings > RS485** to set the parameters.

**Step 2 :** Set the Modbus Address And Baud Rate base on actual situation.

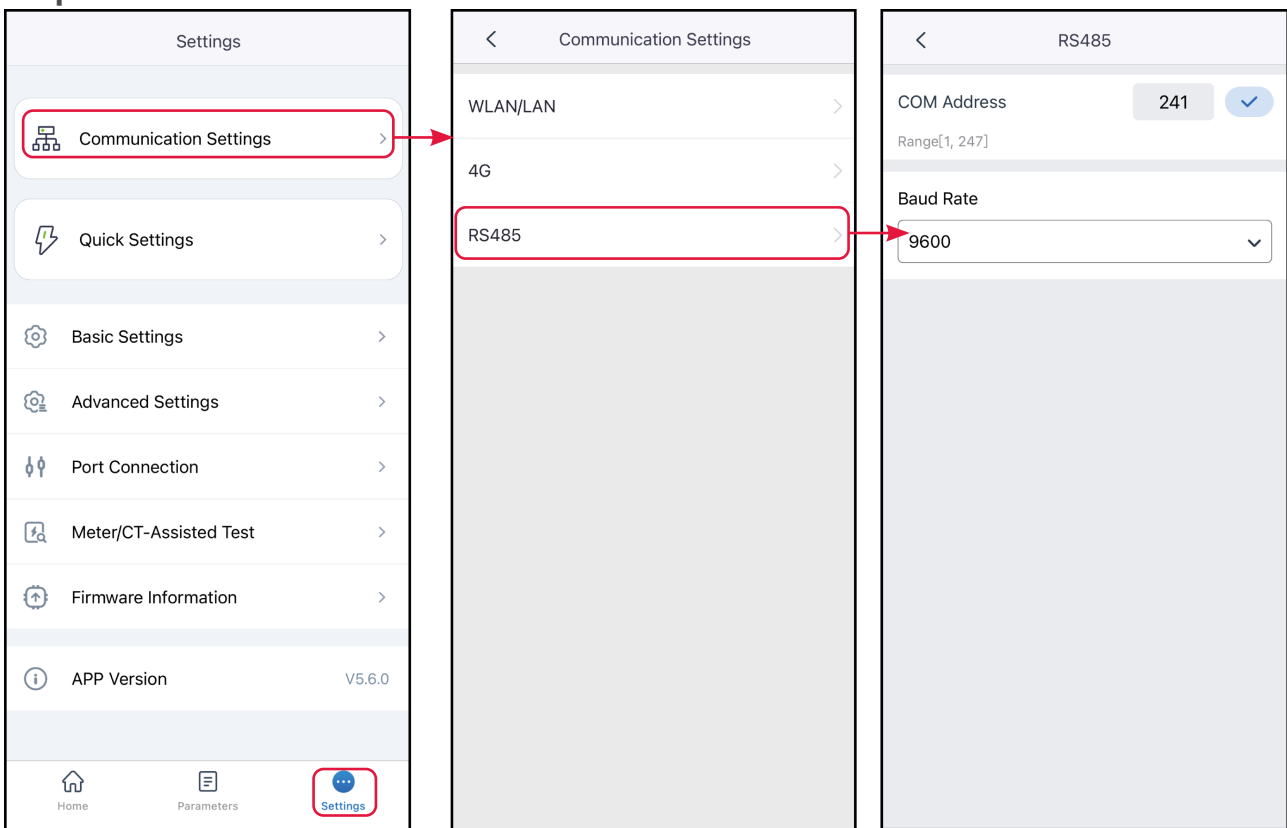

### 7.1.4.4 WLAN Detection

**Step 1 :** Tap **Home > Settings > Communication Settings > WLAN Detection..**

**Step 2 :** Tap **Diagnosis** to check the network connection status.

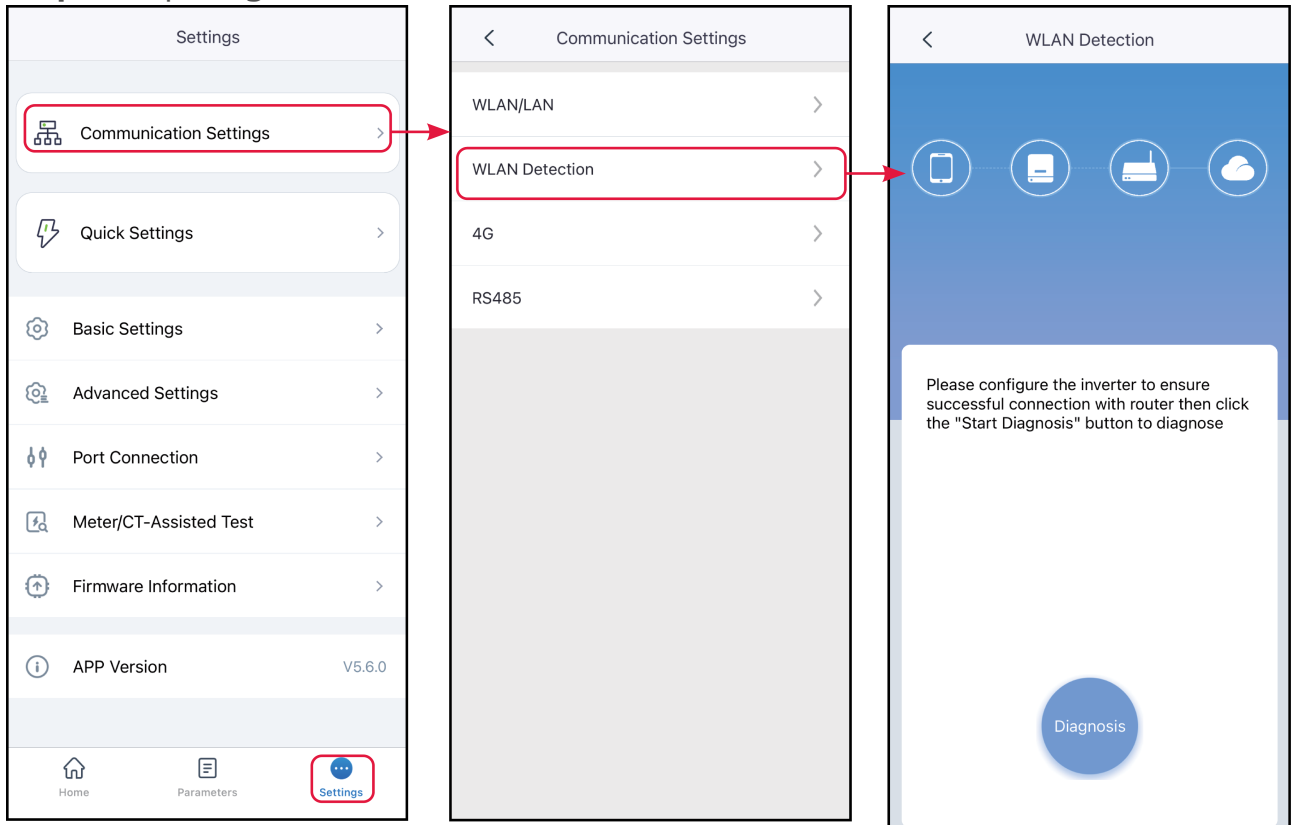

### 7.1.5 Quick Setting the Basic Information

## NOTICE

- The setting page varies depending on inverter model.
- The parameters will be configured automatically after selecting the safety country/region, including overvoltage protection, undervoltage protection, overfrequency protection, underfrequency protection, voltage/frequency connection protection,  $\cos\phi$  curve, Q(U) curve, P(U) curve, FP curve, HVRT, LVRT, etc. Tap Home > Settings > Advanced Settings > Safety Parameters to check the parameters after selecting the safety country.
- The power generation efficiency is different in different working modes. Set the working mode according to the local requirements and situation.
  - Self-use mode: The basic working mode of the system. PV power generation is used to supply power to the load first, the excess power is used to charge the battery, and the remaining power is sold to the grid. When PV power generation cannot meet the load's power demand, the battery will supply power to the load; when the battery power also cannot meet the load's power demand, the grid will supply power to the load.
  - Back-up mode: The back-up mode is mainly applied to the scenario where the grid is unstable. When the grid is disconnected, the inverter turns to off-grid mode and the battery will supply power to the load; when the grid is restored, the inverter switches to grid-tied mode.
  - Economic mode: It is recommended to use economic mode in scenarios when the peak-valley electricity price varies a lot. Select Economic mode only when it meets the local laws and regulations. Set the battery to charge mode during Vally period to charge battery with grid power. And set the battery to discharge mode during Peak period to power the load with the battery.
  - Off-grid mode: suitable for areas without power grid. PV and batteries form a pure off-grid system. PV generates electricity to power the load and excess electricity charges the battery. When PV power generation cannot meet the power demand of the load, the battery will supply power to the load.
  - Smart charging: In some countries/regions, the PV power feed into the utility grid is limited. Select Smart Charging to charge the battery using the surplus power to minimize PV power waste.
  - Peak shaving mode: Peak shaving mode is mainly applicable to peak power limited scenarios. When the total power consumption of the load exceeds the power consumption quota in a short period of time, battery discharge can be used to reduce the power exceeding the quota.

### 7.1.5.1 Quick Setting the Basic Information(Type II)

**Step 1:** Tap **Home > Settings > Quick Settings** to set the parameters.

**Step 2 :** Enter the password for quick settings. Contact the supplier or after sales service for password. Password for professional technicians only.

**Step 3 :** Some models support one-click configuration. Select **Guided Mode** to quickly configure the system.

**Step 4:** Select safety country accordingly. Tap **Next** to set the Battery Connect Mode.

**Step 5 :** Select the actual mode in which the battery is connected to the inverter. The basic settings are completed if there is no battery connected in the system. Tap **Next** to set the Battery Model if there is any battery connected in the system.

**Step 6:** Select the actual battery model. Tap **Next** to set the Working Mode.

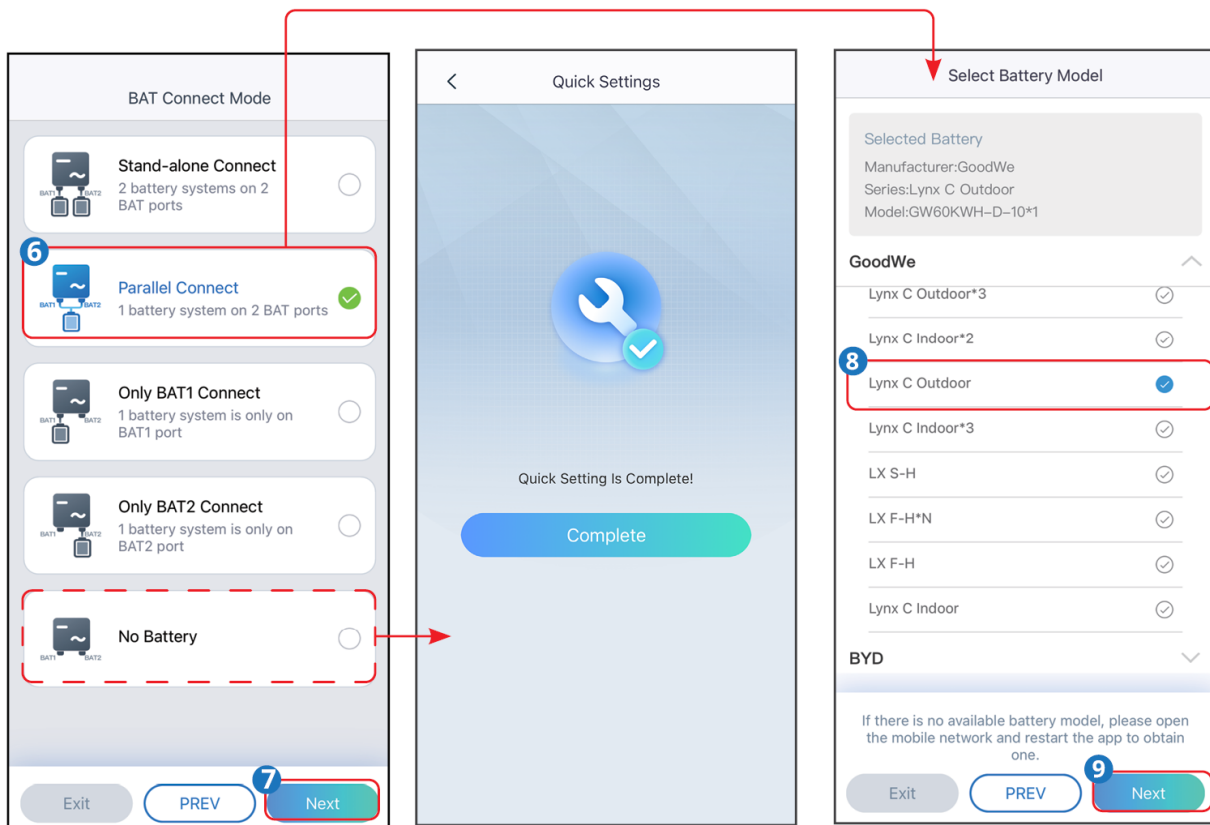
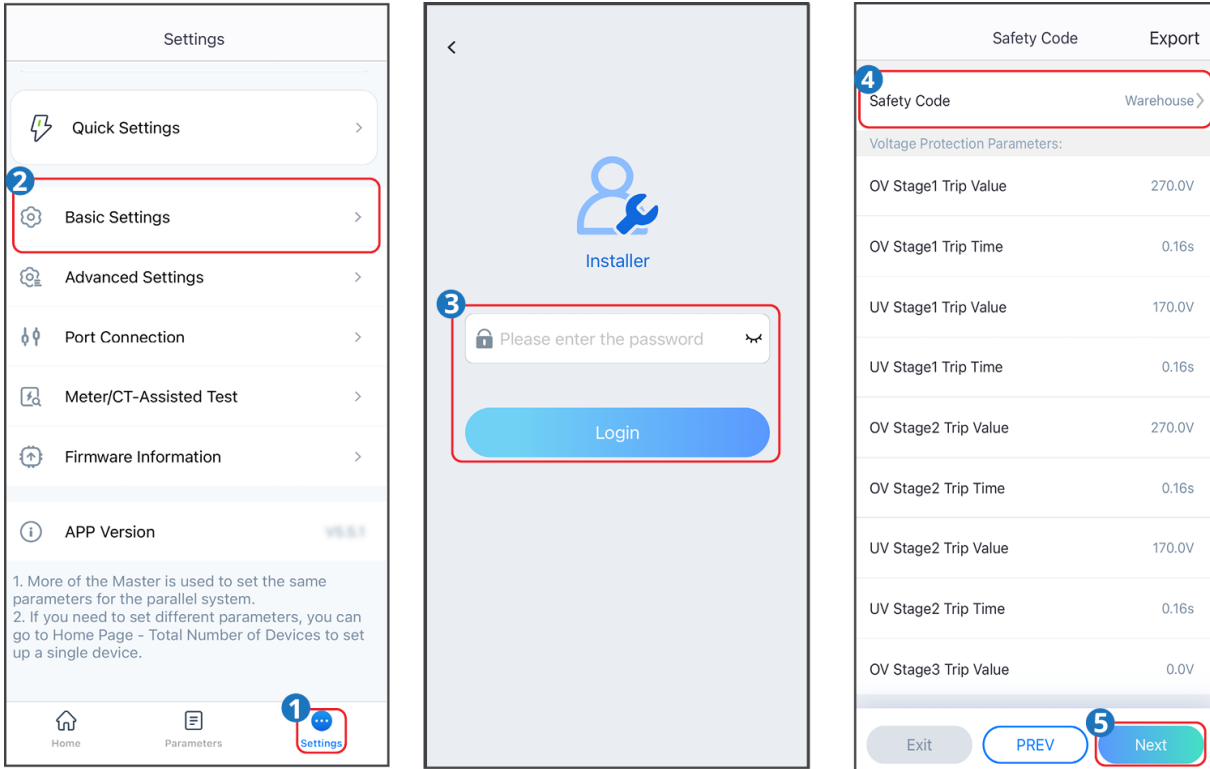

SLG00CON0059

**Step 7:** Set the working mode based on actual needs. Tap **Next** to set the Working Mode. For some models, after the working mode configuration is completed, it will

automatically enter the CT/meter self-test state. At this time, the inverter will temporarily disconnect from the grid and then automatically reconnect.

**Step 8** : Select the battery based on actual situation whether it is **First Installation, Routine Operation** or **Replacement Installation**.

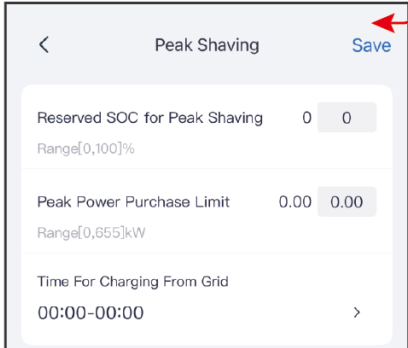
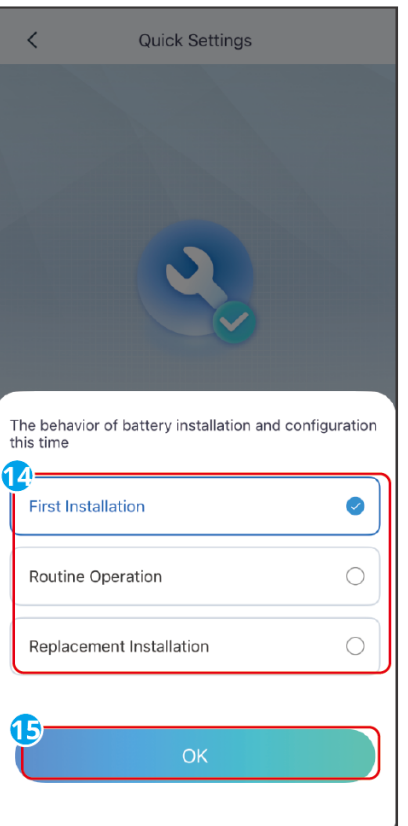
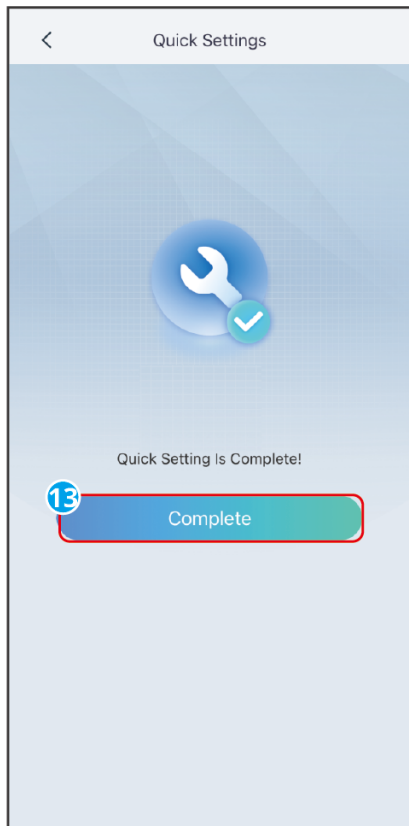
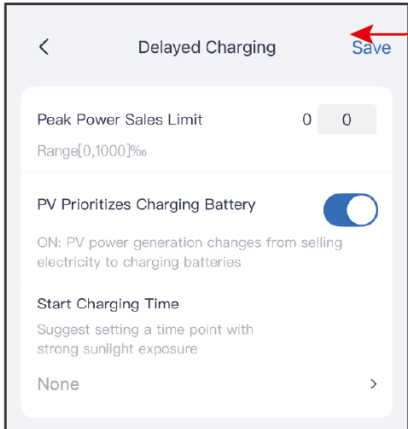
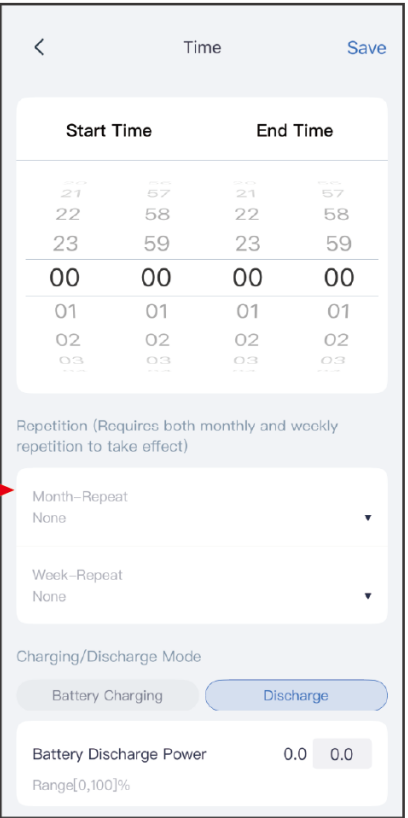
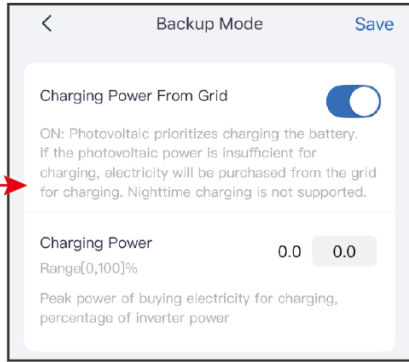
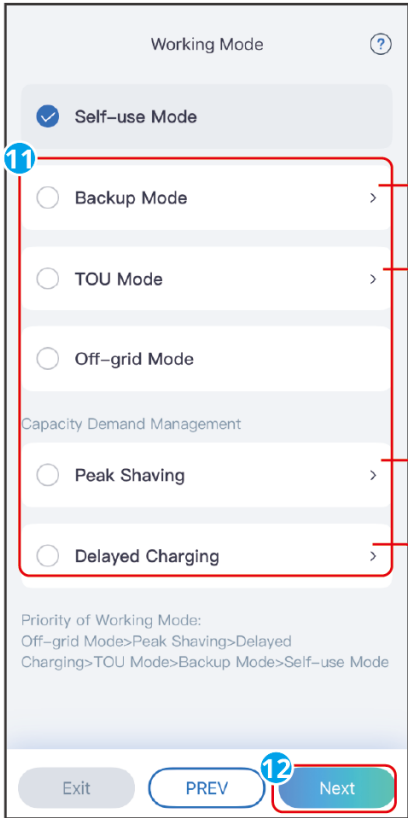

SLG00CON0060

No.	Parameters	Description
Back-up mode		
1	Charging Power From Grid	Enable Charging Power From Grid to allow power purchasing from the utility grid.
2	Charging Power	The percentage of the purchasing power to the rated power of the inverter.
TOU mode		
3	Start Time	Within the Start Time and End Time, the battery is charged or discharged according to the set Battery Mode as well as the Rated Power.
4	End Time	
5	Charge Discharge Mode	Charge or discharge according to actual needs.
6	Rated Power	The percentage of the charging/discharging power to the rated power of the inverter.
7	Charge Cut-off SOC	The battery stop charging/discharging once the battery SOC reaches Charge Cut-off SOC.
Peakshaving		
8	Reserved SOC For Peakshaving	In Peak Shaving mode, the battery SOC should be lower than Reserved SOC For Peakshaving. Once the battery SOC is higher than Reserved SOC For Peakshaving, the peak shaving mode fails.
9	Peak Power Purchase Limit	Set the maximum power limit allowed to purchase from the grid. When the loads consume power exceed the sum of the power generated in the PV system and Peak Power Purchase Limit, the excess power will be made up by the battery.
10	Time for Charging From Grid	The utility grid will charge the battery between Start Time and End Time if the load power consumption do not exceed the power quota. Otherwise, only PV power can be used to charge the battery. Otherwise, only PV power can be used to charge the battery.

No.	Parameters	Description
Smart charging		
11	Peak Power Sales Limit	Set the Peak Power Sales Limit in compliance with local laws and regulations. The Peak Limiting Power shall be lower than the output power limit specified by local requirements.
12	PV Prioritizes Charging Battery	During charging time, the PV power will first charge the battery.
13	Start Charging Time	

## 7.1.6 Setting the Basic Information

### 7.1.6.1 Setting the SPD

After enabling SPD, when the SPD module is abnormal, there will be SPD module abnormal alarm prompt.

**Step 1** : Tap **Home > Settings > Basic Settings > SPD**, to set the parameters.

**Step 2** : enable or disable the function based on actual needs.

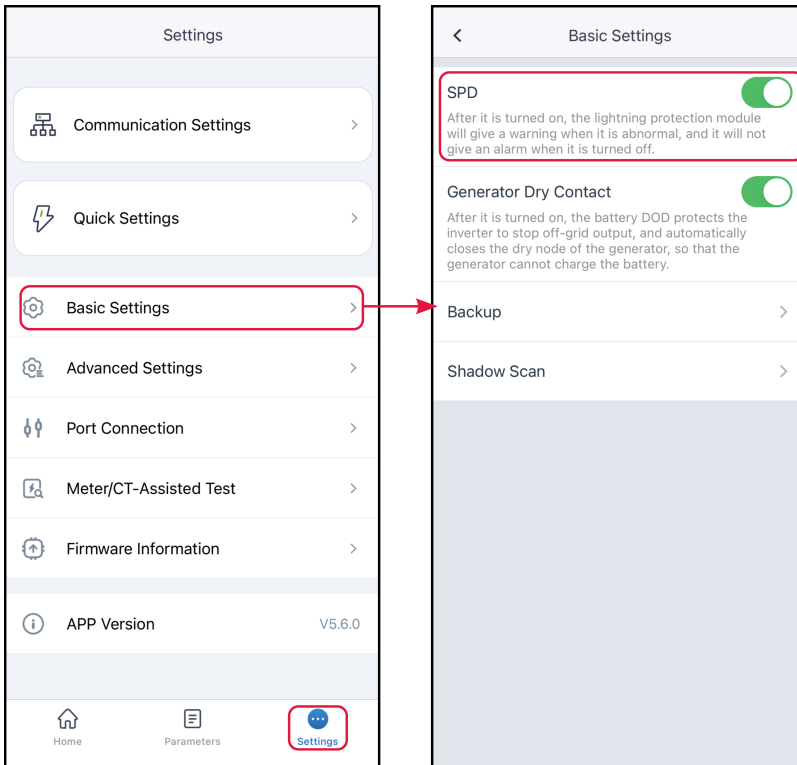

### 7.1.6.2 Setting the Shadow Scan

Enable Shadow Scan when the PV panels are severely shadowed to optimize the power generation efficiency.

**Step 1 :** Tap **Home > Settings > Basic Settings> Shadow Scan**, to set the parameters.

**Step 2:** Enable or disable the function based on actual needs. Set the Shadow Scan interval and MPPT shadow scan if the inverter supports.

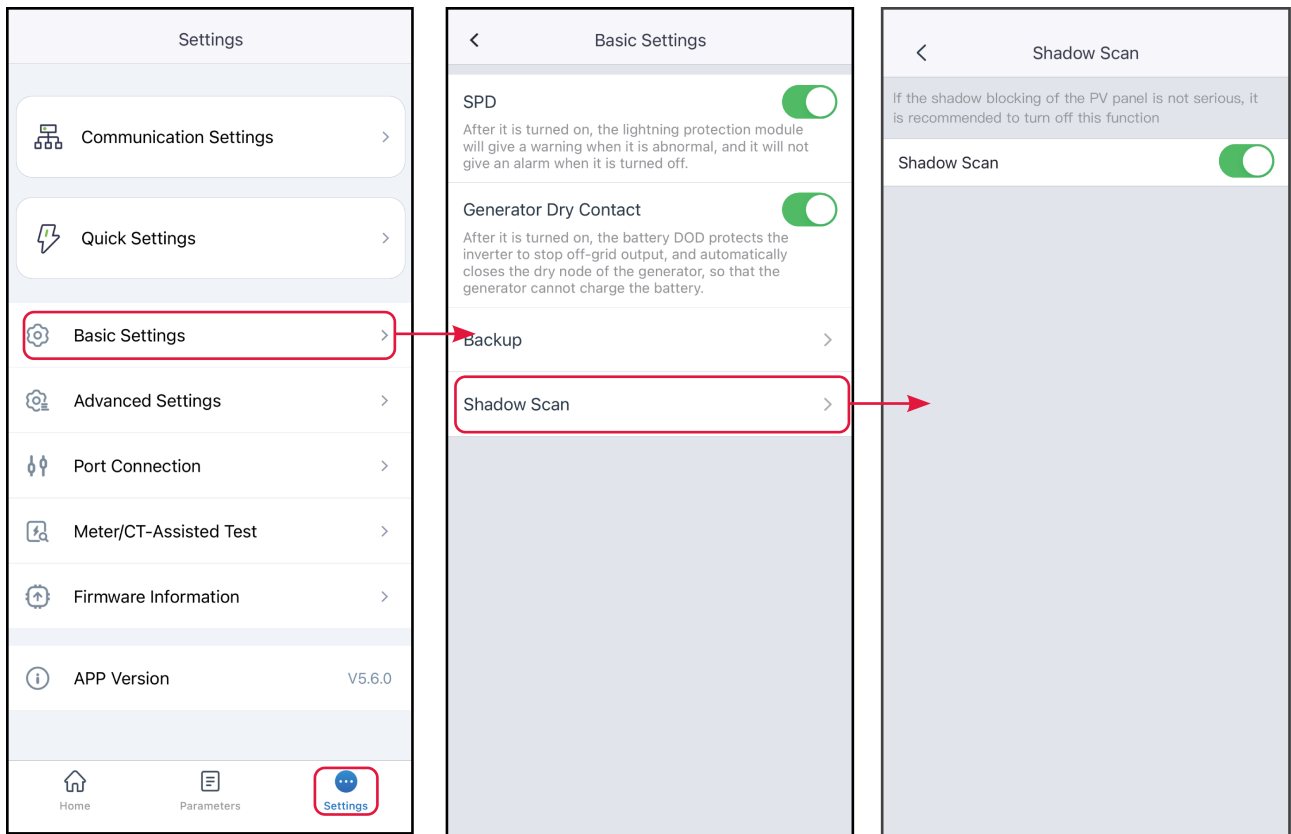

### 7.1.6.3 Setting the Back-up Power Parameters

After enabling Backup, the battery will power the load connected to the backup port of the inverter to ensure Uninterrupted Power Supply when the power grid fails.

**Step 1** : Tap **Home** > **Settings** > **Basic Settings** > **Backup**, to set the parameters.

**Step 2** : Set the backup supply function based on actual needs.

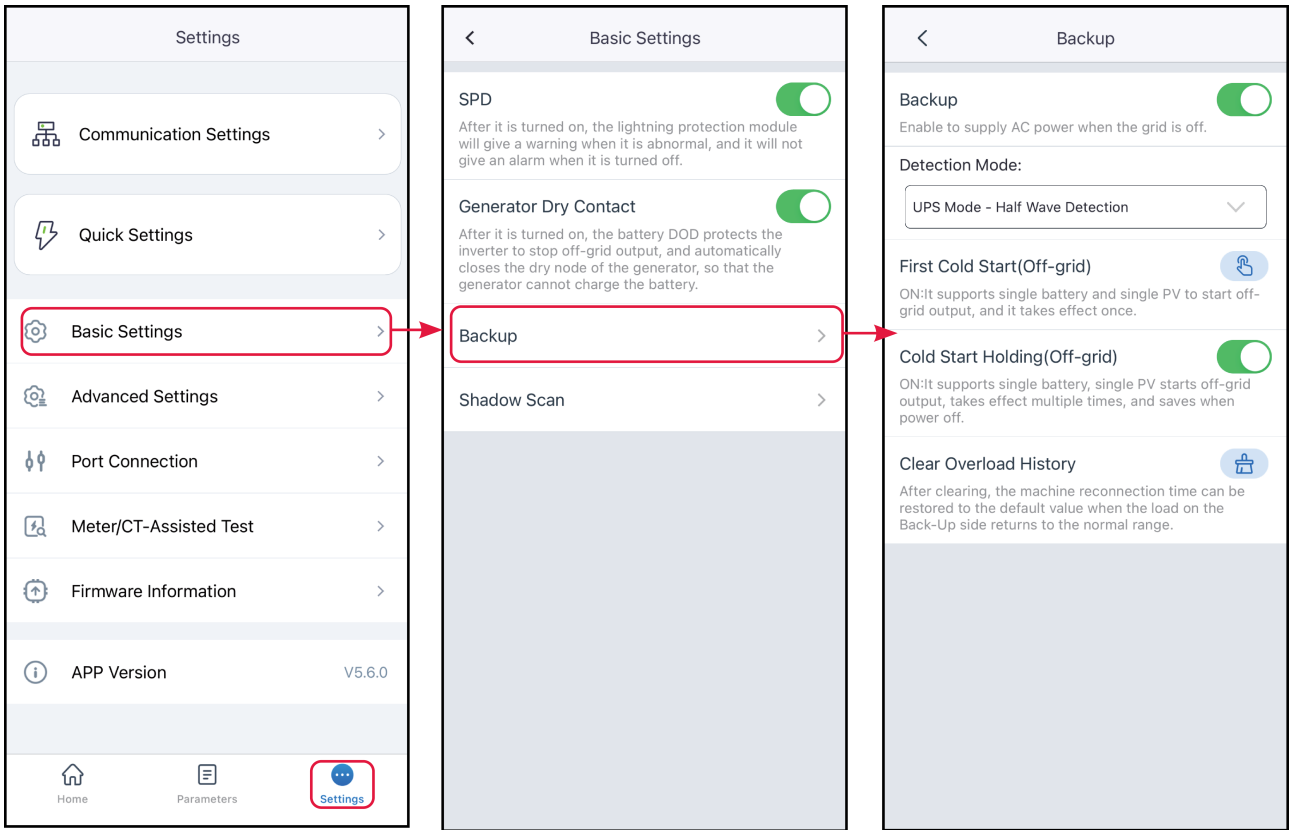

No.	Parameters	Description
1	UPS Mode- Full Wave Detection	Check whether the utility grid voltage is too high or too low.
2	UPS Mode- Half Wave Detection	Check whether the utility grid voltage is too low.
3	EPSmode-with LVRT support.	Stop detecting utility grid voltage.
4	First Cold Start (Off-grid)	It will only take effect once. In off-grid mode, enable First Cold Start (Off-grid) to output backup supply with battery or PV.
5	Cold Start Holding (Off-grid)	Take effect multiple times. In off-grid mode, enable First Cold Start (Off-grid) to output backup supply with battery or PV.

No.	Parameters	Description
6	Clear Overload History	Once the power of loads connected to the inverter BACK-UP ports exceeds the rated load power, the inverter will restart and detect the power again. The inverter will perform restart and detection several times until the overloading problem is solved. Tap Clear Overload History to reset the restart time interval after the power of the loads connected to the BACK-UP ports meets the requirements. The inverter will restart immediately.

#### 7.1.6.4 Setting Power Adjustment Parameters

**Step 1:** Go to the settings interface via **Home > Settings > Basic Settings > Power Scheduling**.

**Step 2:** Set the active power dispatch or reactive power dispatch parameters according to the actual situation.

< Active Dispatch

Local control: Self-control according to user needs;  
Remote control: Passive control according to the requirements of the power grid (enabled by default).

Current Active Power Dispatch Mode:

Extreme Speed Percentage Derating(Remote) 100.0%

Local Control

Active Dispatch Mode:

Active Power (W) ✓

Active Power 11000 11000 ✓

Range[-400000,400000]W

< Reactive Scheduling

Local control: Self-control according to user needs;  
Remote control: Passive control according to the requirements of the power grid (enabled by default).

Reactive Power Dispatch Mode

Disable

Local Control

Select Mode:

Disable ✓

Fixed Value Compensation

Percentage Compensation

PF Compensation

SLG00CON0124

No.	Parameter	Description
		Active Scheduling

No.	Parameter	Description
1	Active Scheduling Mode	<p>According to the requirements of the power grid company in the country/region where the inverter is located, control the active power according to the selected dispatch mode. Supports:</p> <ul style="list-style-type: none"> <li>• Disabled: Disables active scheduling.</li> <li>• Fixed value reduction: Dispatch according to a fixed value.</li> <li>• Percentage reduction: Dispatch based on a percentage of the rated power.</li> </ul>
2	Active Power	<ul style="list-style-type: none"> <li>• When the active power dispatch mode is set to fixed value derating, the active power is set to a fixed value.</li> <li>• When the active power dispatch mode is set to percentage derating, the active power is set as a percentage of the rated power. 比。</li> </ul>
Reactive Scheduling		
3	Reactive Scheduling Mode	<p>According to the requirements of the power grid company in the country/region where the inverter is located, control the reactive power according to the selected dispatch mode. Supports:</p> <ul style="list-style-type: none"> <li>• Disabled: Disables reactive scheduling.</li> <li>• Fixed value compensation: Dispatch according to a fixed value.</li> <li>• Percentage compensation: Dispatch based on a percentage of the rated power.</li> <li>• PF compensation.</li> </ul>
4	Status	Set the power factor as lagging or leading based on actual needs and local grid standards and requirements.

No.	Parameter	Description
5	Reactive Power	<ul style="list-style-type: none"> <li>When the reactive power dispatch mode is set to fixed value derating, the reactive power is set to a fixed value.</li> <li>When the reactive power dispatch mode is set to percentage derating, the reactive power is set as a percentage of the rated power.</li> </ul>
6	Power Factor	When the reactive power dispatch mode is set to PF compensation, set the power factor.

## 7.1.7 Setting Advanced Parameters

### NOTICE

Contact the supplier or after sales service for Advanced Setting password.  
Password for professional technicians only.

### 7.1.7.1 Setting DRED/Remote Shutdown/RCR/EnWG 14a

Enable DRED/Remote Shutdown/RCR before connecting the third party DRED, remote shutdown, or RCR device to comply with local laws and regulations.

**Step 1** : Tap **Home > Settings > Advanced Settings > DRED/Remote Shutdown/RCR** to set the parameters.

**Step 2** : Enable or disable the function based on actual needs.

**Step 3** : For areas where the EnWG 14a regulation applies, when enabling the RCR function, you need to select the RCR mode according to the actual device type and set the DI port power.

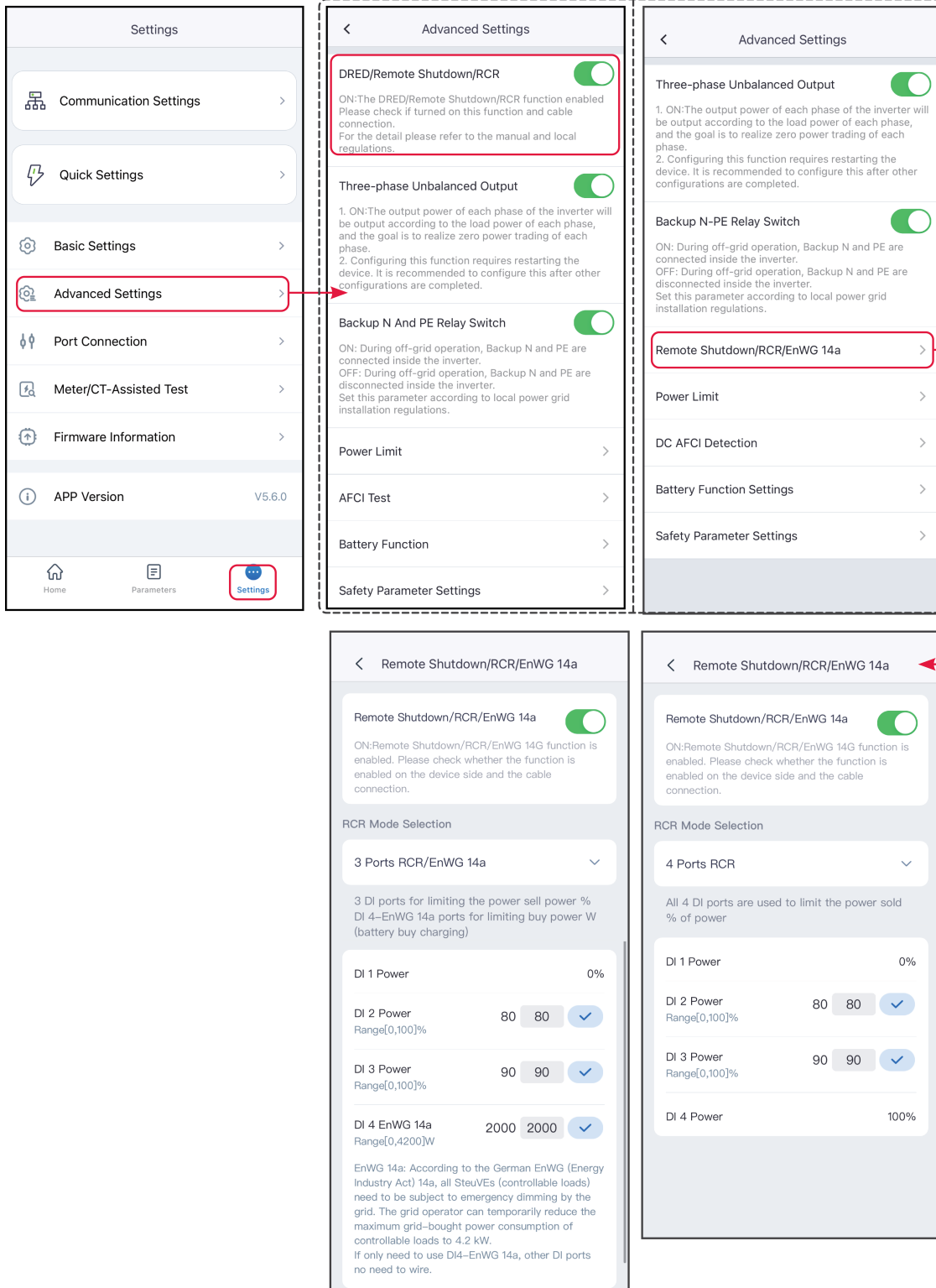

### 7.1.7.2 Setting Three-phase Unbalanced Output

Enable the Three-phase unbalanced output when connecting unbalanced loads,

which means L1, L2, L3 of the inverter respectively connected to loads with different power. Only for three phase inverters.

**Step 1 :** Tap **Home > Settings > Advanced Settings > Three-phase Unbalanced Output** to set the parameters.

**Step 2 :** Enable or disable the function based on actual needs.

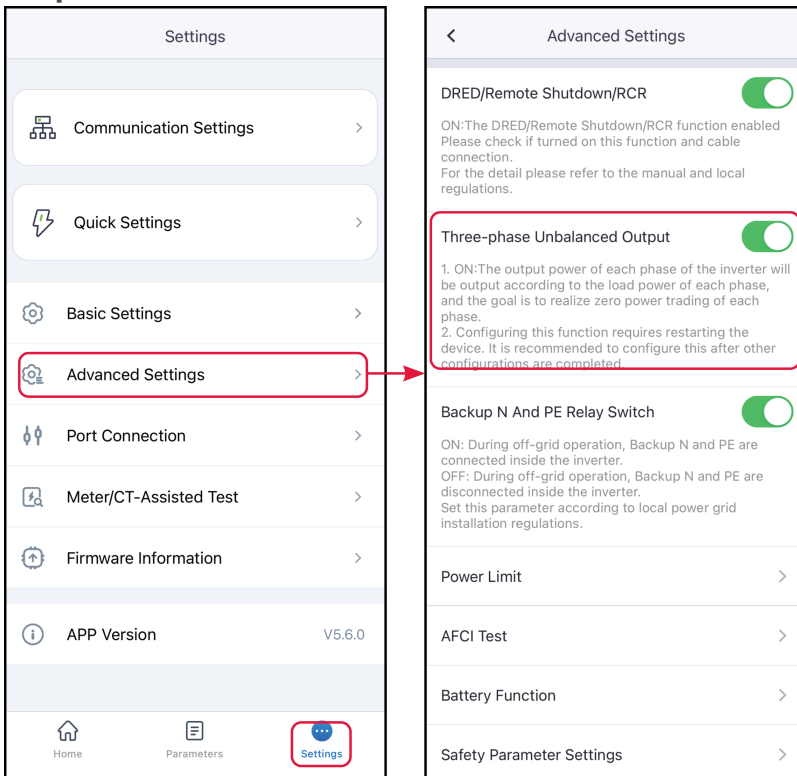

### 7.1.7.3 Setting the Backup N and PE Relay Switch

To comply with local laws and regulations, ensure that the relay inside the back-up port remains closed and the N and PE wires are connected when the inverter is working off-grid.

**Step 1 :** Tap **Home > Settings > Advanced Settings > Backup N and PE Relay Switch** to set the parameters.

**Step 2 :** Enable or disable the function based on actual needs.

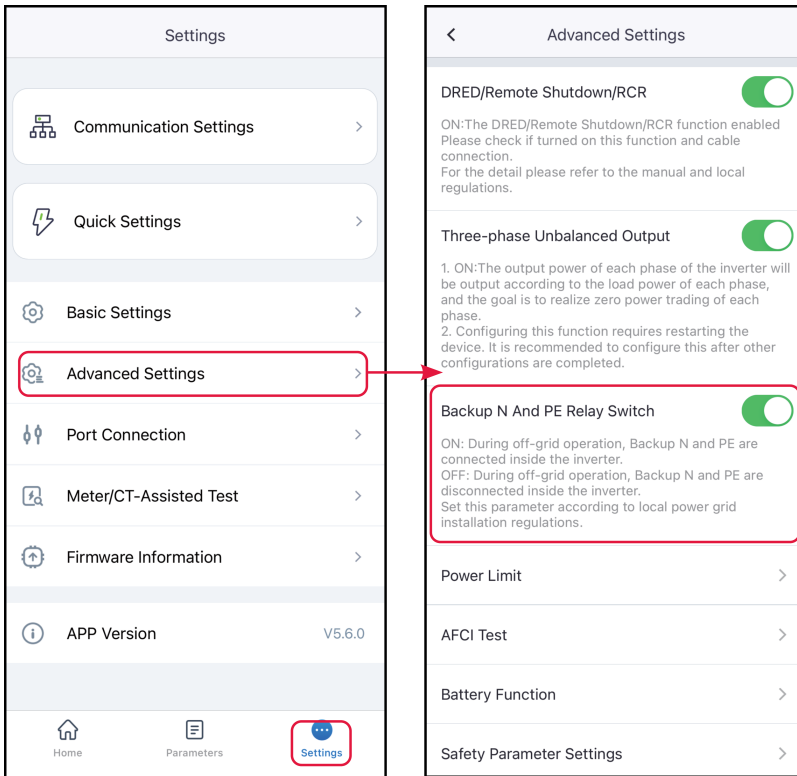

### 7.1.7.4 Setting the Power Limit Parameters

**Step 1:** Tap **Home** > **Settings** > **Advanced Settings** > **Power Limit** to set the parameters.

**Step 2 :** Turn on or off the power limit function according to actual needs.

**Step 3 :** After turning on the function, enter the parameter value according to actual needs and tap "v" to successfully set the parameter.

#### 7.1.7.4.1 Set the grid-connected power limit parameters (general)

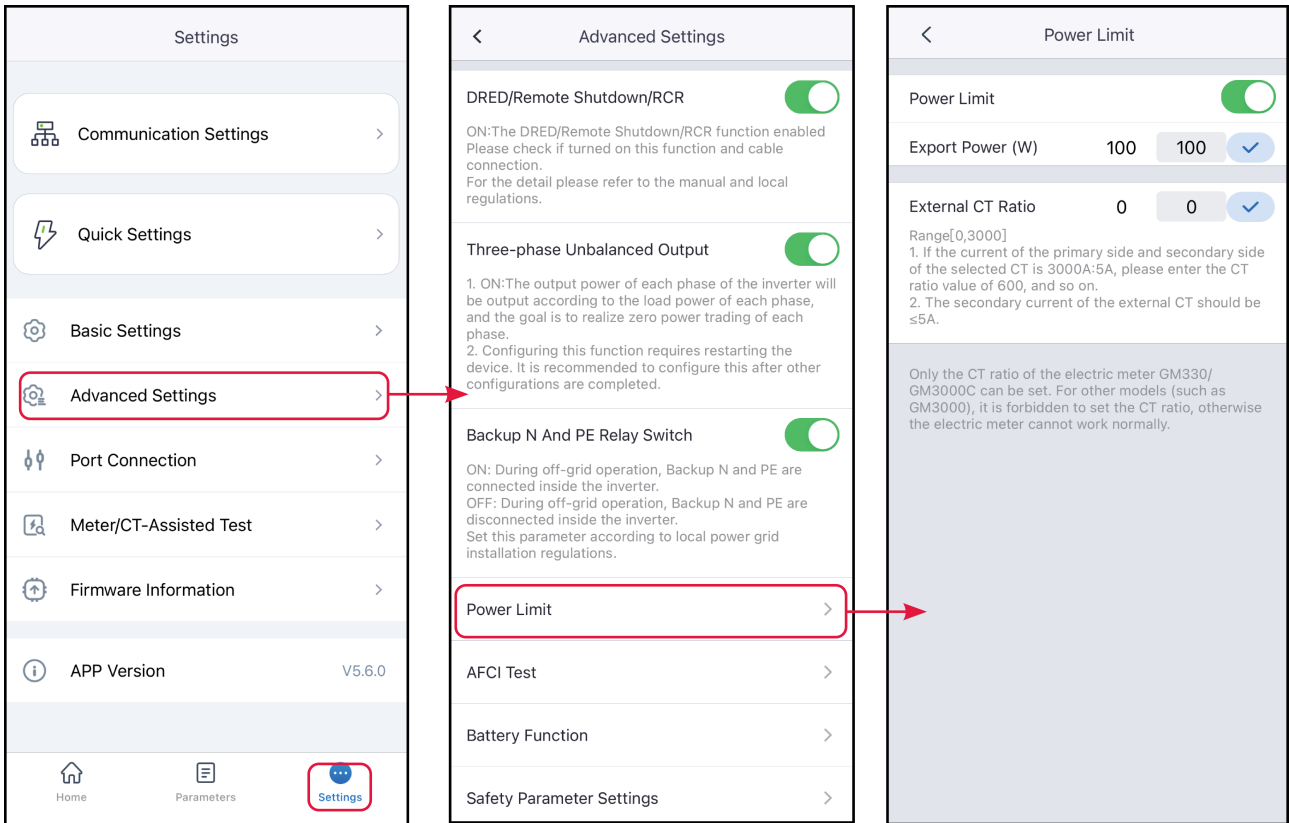

No.	Parameters	Description
1	Power Limit	Turn on this function when output power needs to be limited according to the grid standards of some countries or regions.
2	Export Power	Set according to the maximum power that can be input to the grid.
3	External Meter CT ratio	Set the ratio of the primary current to the secondary current of the external CT.

#### 7.1.7.4.2 Setting the Power Limit Parameters (Australia)

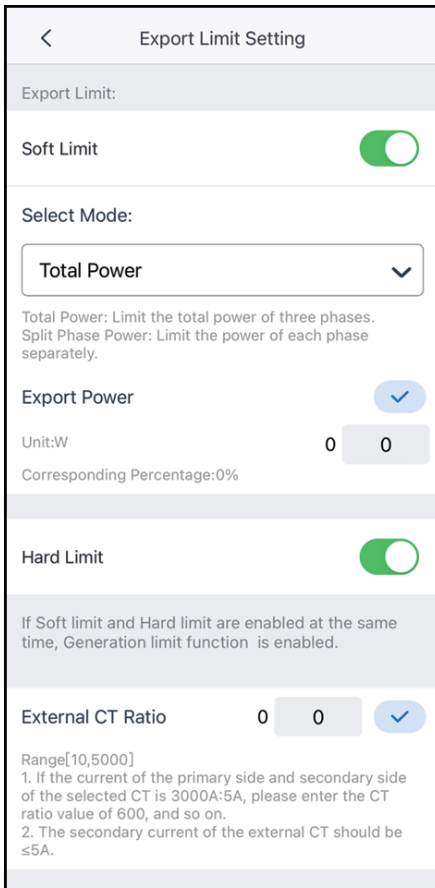

SLG00CON0133

No.	Parameters	Description
1	Software Power Limit	When output power needs to be limited according to grid standards in some countries or regions, turn on this function.
2	Limit Setting	<ul style="list-style-type: none"> <li>• Set according to the maximum power that can be actually input to the grid.</li> <li>• Supports setting of fixed power value or percentage. The set percentage is the percentage of the limit power to the rated power of the inverter.</li> <li>• After setting the fixed value, the percentage changes automatically; after setting the percentage, the fixed value changes automatically.</li> </ul>

No.	Parameters	Description
3	Hardware Power Limit	After enabling this function, when the amount of electricity fed into the grid exceeds the limit value, the inverter will automatically disconnect from the grid.
4	External Meter CT Ratio	Set the ratio of the primary current to the secondary current of the external CT.

### 7.1.7.5 Setting the AFCI Detection

**Step 1 :** Tap Home > Settings > Advanced Settings > AFCI Test to set the parameters.

**Step 2 :** Enable AFCI Test, Clear AFCI Alarm and Self-Check based on actual needs.

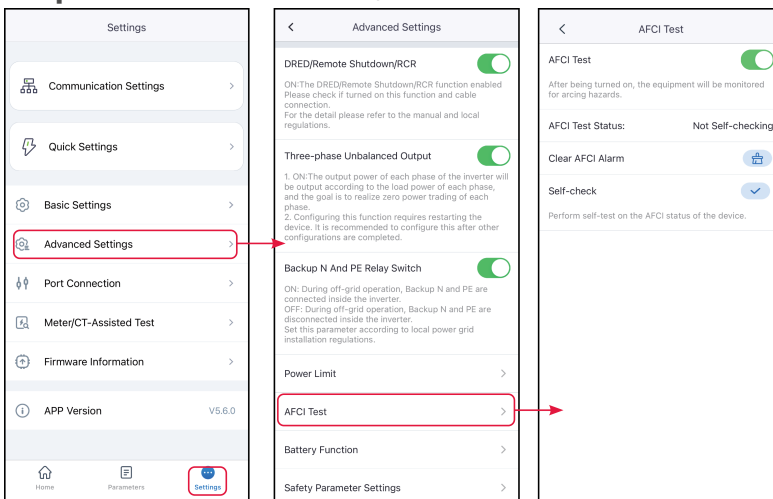

No.	Parameters	Description
1	AFCI Test	Enable or disable AFCI accordingly.
2	AFCI Test Status	The detection status like Not Self-checking.
3	Clear AFCI Alarm	Clear ARC Faulty alarm records.
4	Self-check	Tap to check whether the AFCI function works normally.

### 7.1.7.6 Setting PV Connect Mode

Select the PV connect mode based on the actual connections between the PV strings

and MPPT ports of the inverter.

**Step 1 :** Tap **Home > Settings > Advanced Settings > PV Connect Mode** to set the parameters.

**Step 2 :** Set the connect mode to Independent Access, Partial Parallel Connect or Parallel Connection based on actual connections.

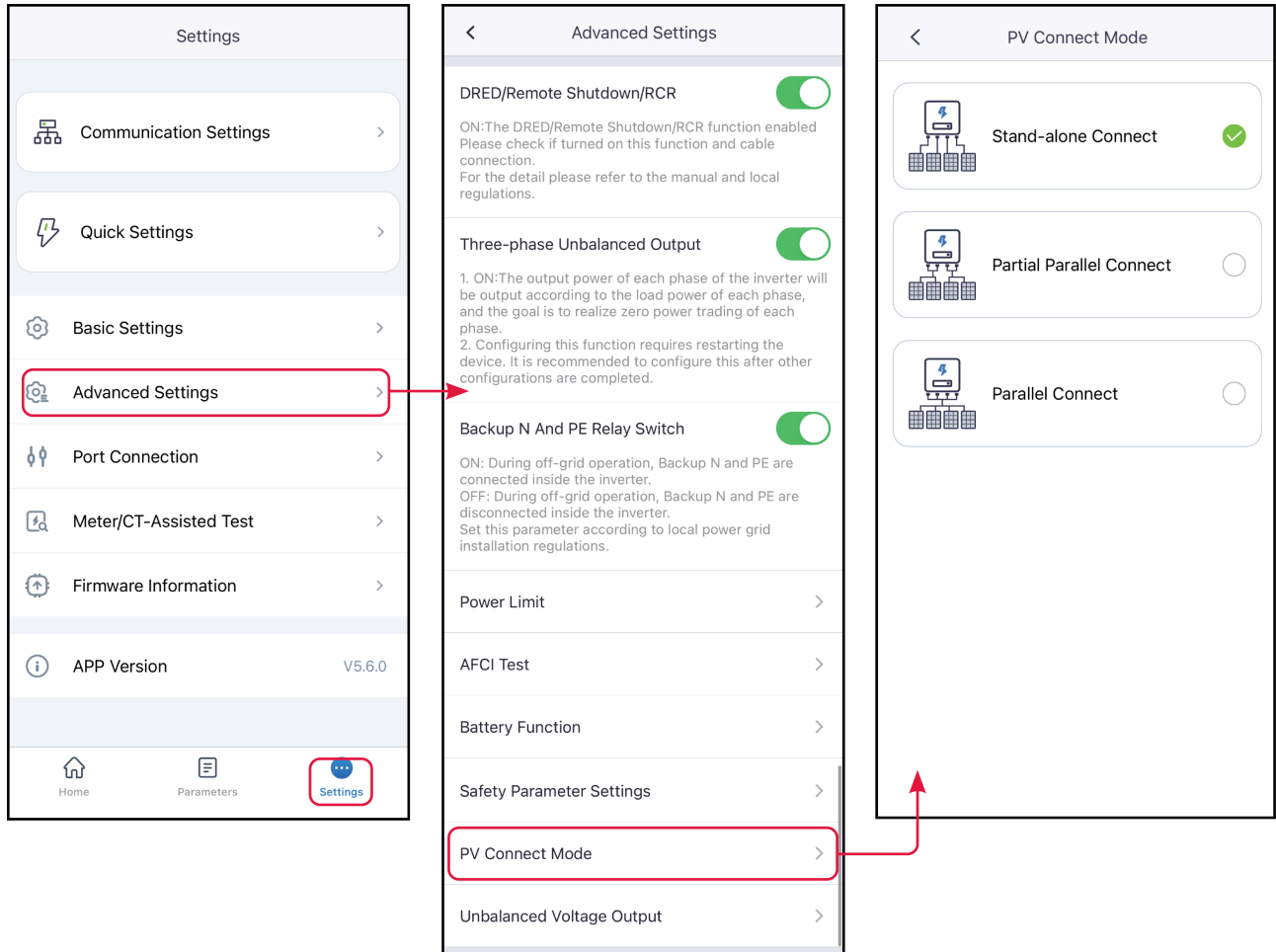

No.	Parameters	Description
1	Stand-alone Connect	The external PV string is connected to multi MPPT terminals of the inverter.
2	Partial Parallel Connect	The PV strings are connected to the inverter in both stand-alone and parallel connection. For example, one PV string connect to MPPT1 ad MPPT2, another PV string connect to MPPT3.

No.	Parameters	Description
3	Parallel Connect	When an external PV string is connected to the PV input port on the inverter side, one PV string is connected to multiple PV input ports.

### 7.1.7.7 Setting the Unbalanced Voltage Output

**Step 1 :** Tap **Home > Settings > Advanced Settings > Unbalanced Voltage Output** to see the parameters.

**Step 2 :** Enable or disable the function based on actual needs.

**Step 3 :** After enabling the Unbalance Voltage Function, set parameters based on actual needs. And tap 'V'. The parameters are set successfully.

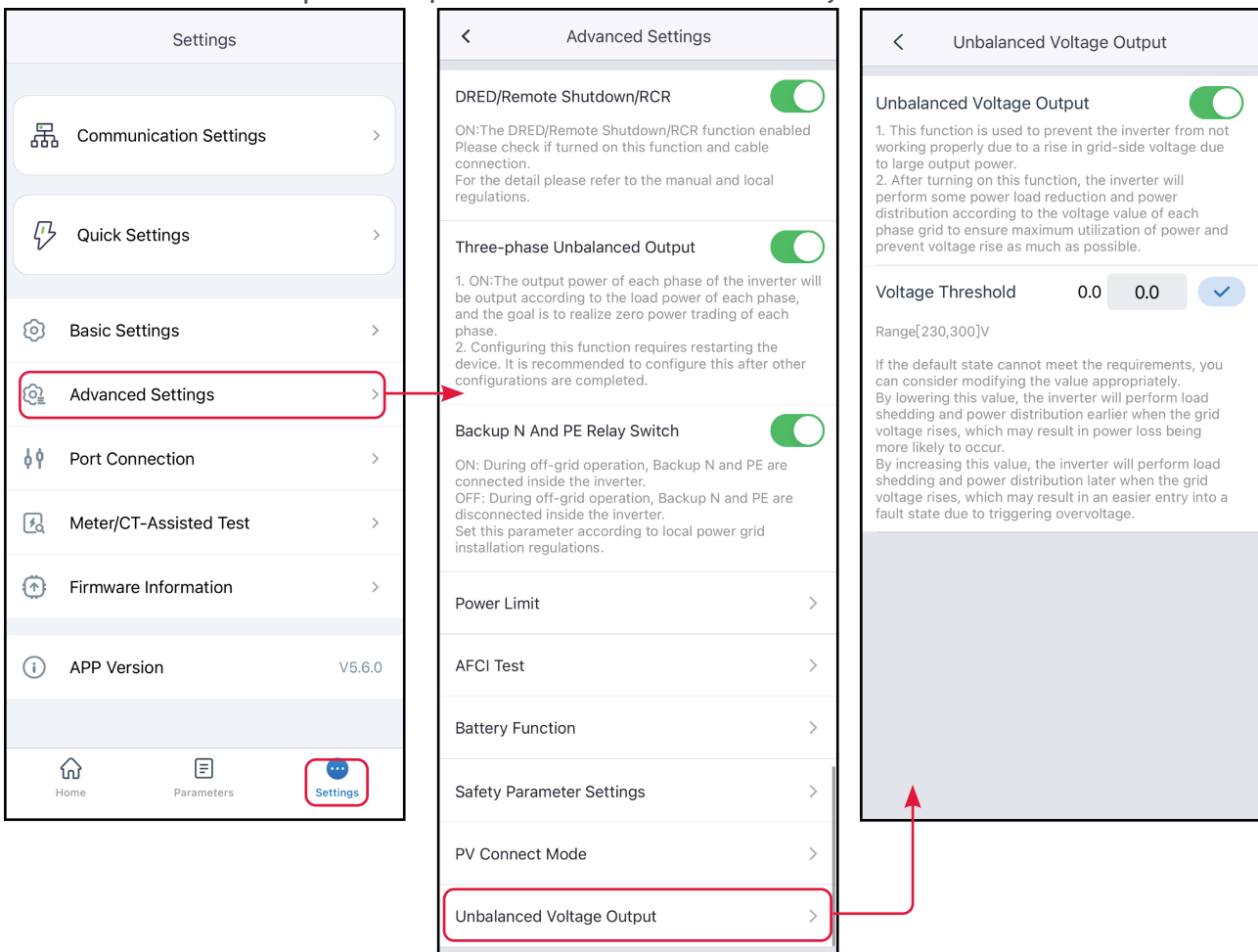

### 7.1.7.8 Setting Power Adjustment Response Parameters

**Step 1:** Go to the parameter settings page via **Home > Settings > Advanced Settings**

> **Power Adjustment Response Parameters.**

**Step 2:** Based on actual requirements, select **Disable**, **Slope Adjustment**, or **First-Order Low-Pass Filter** Mode from the Active Power Adjustment drop-down menu. If you select slope adjustment, enter the power change gradient value; if you select first-order low-pass filter mode, enter the first-order low-pass filter time parameter value.

**Step 3:** Based on actual requirements, select **Disable**, **Slope Adjustment**, or **First-Order Low-Pass Filter** Mode from the Reactive Power Adjustment drop-down menu. If you select slope adjustment, enter the power change gradient value; if you select first-order low-pass filter mode, enter the first-order low-pass filter time parameter value.

**Step 4:** Click ✓ to save the settings.

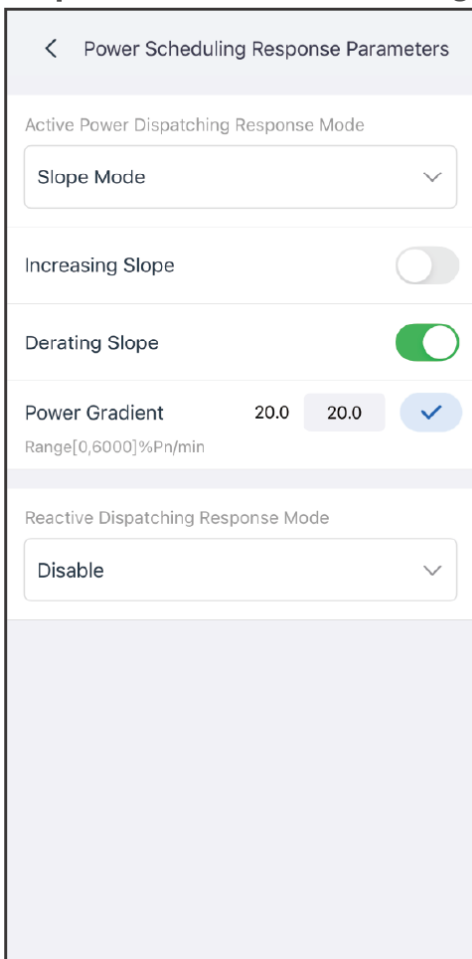

SLG00CON0125

No.	Parameter	Description
	Active Adjustment Response Mode	

No.	Parameter	Description
1	First-order Low-pass Filter	Within the response time constant, active adjustment is implemented according to a first-order low-pass curve.
2	First-order Low-pass Filter Time Parameter	Set the time constant within which the active power changes based on the first order LPF curve.
3	Slope Adjustment	Implement active power dispatch based on the power change slope.
4	Power Change Gradient	Set the slope of active power adjustment changes.
Reactive Adjustment Response Mode		
5	First-order Low-pass Filter	Within the response time constant, reactive adjustment is implemented according to a first-order low-pass curve.
6	First-order Low-pass Filter Time Parameter	Set the time constant within which the reactive power changes based on the first order LPF curve.
7	Slope Adjustment	Implement reactive power dispatch based on the power change slope.
8	Power Change Gradient	Set the slope of reactive power adjustment changes.

### 7.1.7.9 Setting the Power Scheduling Parameters

Active power or reactive power can be regulated by directly setting the power value, a percentage of rated power, or the power factor (PF) value.

**Step 1:** Tap **Home > Settings > Basic Settings > Power Dispatch Parameter Settings** to set the parameters.

**Step 2:** In the Active Power Dispatch Mode dropdown menu, select one of the following based on your requirements: **Disabled, Active Power Setpoint(W)**, or **Active Power Setpoint(%)**.

**Step 3:** In the Reactive Power Dispatch Mode dropdown menu, select one of the following based on your requirements: **Disabled, Reactive Power Setpoint(Var)**, **Reactive Power Setpoint(%)**, or **PF Compensation**.

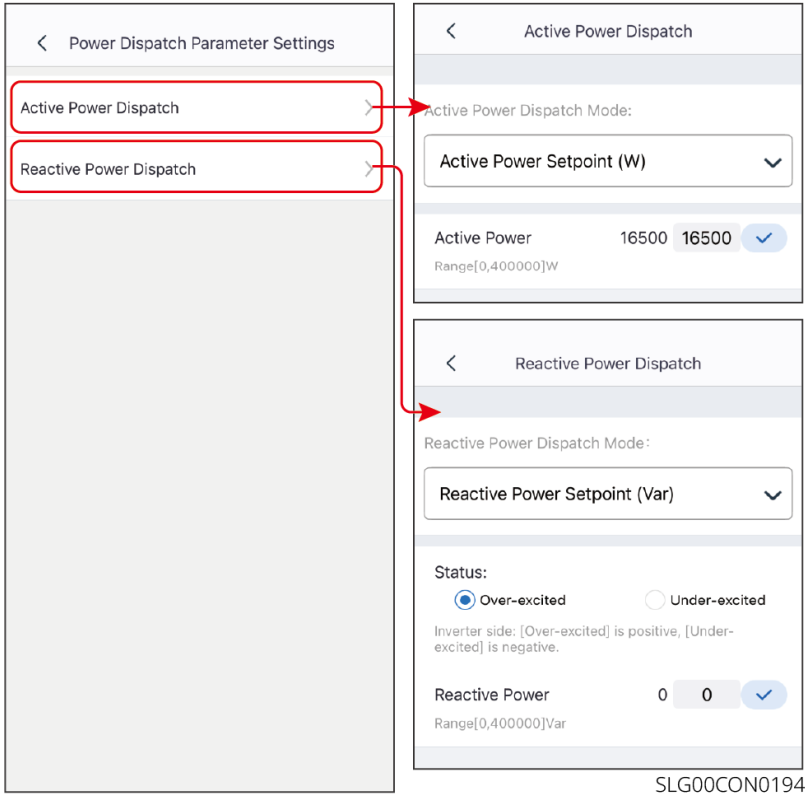

SLG00CON0194

### 7.1.7.10 Restore Factory Settings

To restore the device to its factory default settings, perform the following steps.

**Step 1:** Go to the settings page by selecting **Home > Settings > Advanced Settings > Restore Factory Settings**.

**Step 2:** Tap **Restore Factory Settings** to restore the interface prompt section to factory settings.

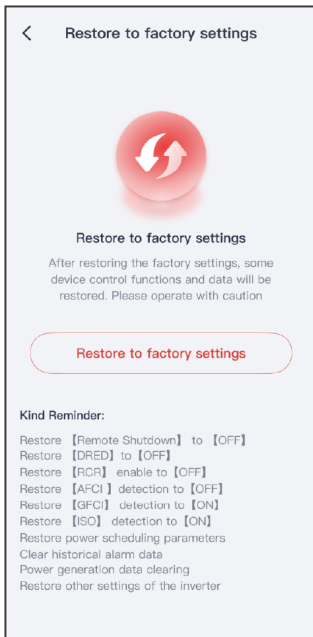

SLG00CON0122

## 7.1.8 Setting the Battery

### 7.1.8.1 Set Parameters for Lithium Battery

**Step 1:** Tap **Home > Settings > Advanced Settings > Battery Function Settings** to set the parameters.

**Step 2:** Set the parameters based on actual needs.

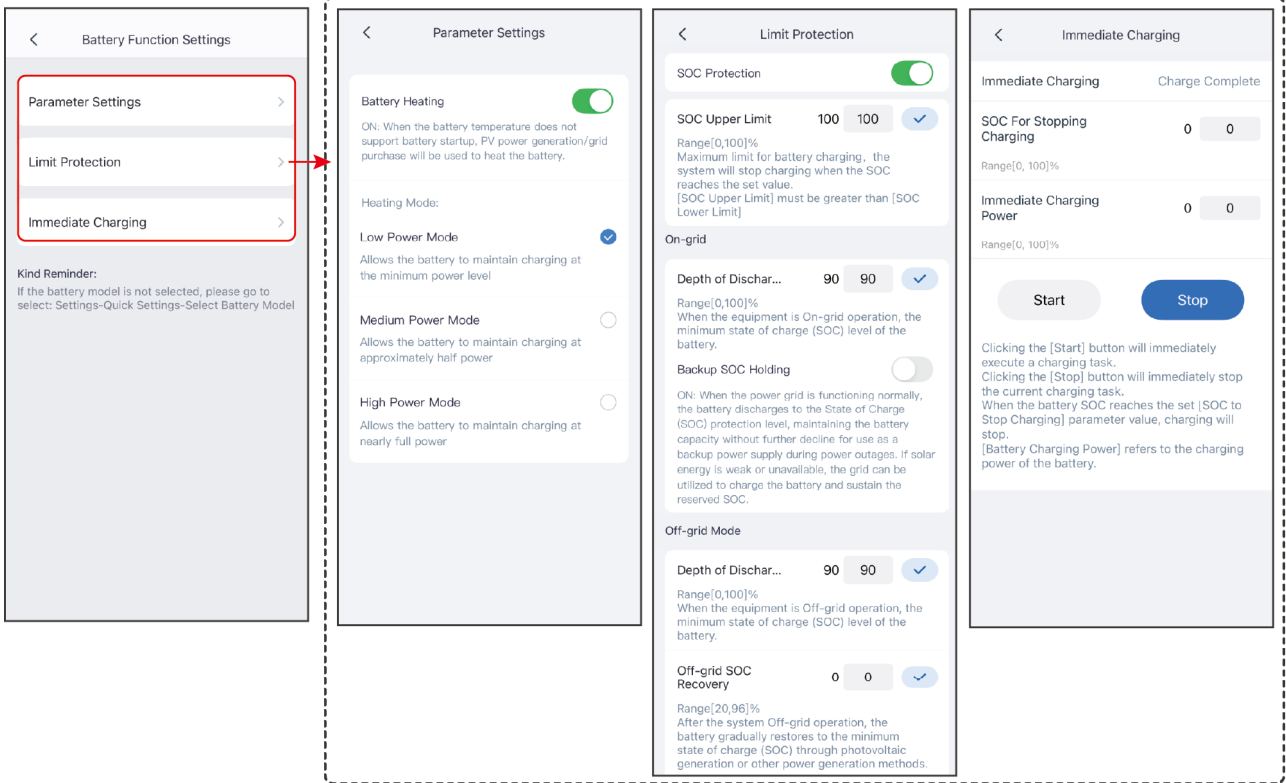

SLG00CON0072

No.	Parameter	Description
Parameter Settings		
1	Max. Charging Current	Only applicable to certain models. Set the maximum charging current based on actual needs.
2	Max. Discharging Current	Only applicable to certain models. Set the maximum discharging current based on actual needs.

No.	Parameter	Description
3	Battery Heating	<p>Optional. This option is displayed on the interface when a battery that supports heating is connected. After the battery heating function is turned on, when the temperature is below the value that starts up the battery, PV power or electricity from the grid will be used to heat the battery.</p> <p>Heating Mode:</p> <ul style="list-style-type: none"> <li>• GW5.1-BAT-D-G20/GW8.3-BAT-D-G20 <ul style="list-style-type: none"> <li>◦ Low Power Mode: Maintains minimum battery power input capacity, turns on when the temperature is below -9°C, and turns off when the temperature is above or equal to -7°C.</li> <li>◦ Medium Power Mode: to maintain the moderate power input capacity of the battery. It will be turned on when the temperature is less than 6°C, and turned off when it is greater than or equal to 8°C.</li> <li>◦ High Power Mode: to maintain the higher power input capacity of the battery. It will be turned on when the temperature is less than 11°C, and turned off when it is greater than or equal to 13°C.</li> </ul> </li> <li>• GW14.3-BAT-LV-G10 <ul style="list-style-type: none"> <li>◦ Low Power Mode: Maintains minimum battery power input capacity, turns on when the temperature is below 5°C, and turns off when the temperature is above or equal to 7°C.</li> <li>◦ Medium Power Mode: to maintain the moderate power input capacity of the battery. It will be turned on when the temperature is less than 10°C, and turned off when it is greater than or equal to 12°C.</li> <li>◦ High Power Mode: to maintain the higher power input capacity of the battery. It will be turned on when the temperature is less than 20°C, and turned off when it is greater than or equal to 22°C.</li> </ul> </li> </ul>

No.	Parameter	Description
4	Battery Wake-up	<ul style="list-style-type: none"> <li>• After being turned on, the battery can be awakened when it shuts down due to undervoltage protection.</li> <li>• Only applicable to lithium batteries without circuit breakers. After being turned on, the output voltage of the battery port is about 60V.</li> </ul>
Limit Protection		
5	SOC Protection	Start battery protection when the battery capacity is lower than the Depth of Discharge.
6	SOC Limit	The upper limit value for battery charging. Charging stops when the battery SOC reaches the SOC upper limit.
7	Discharge Depth (On-grid)	The maximum discharge value allowed for the battery when the inverter is in the on-grid scenario.
8	Backup Power SOC Maintenance	To ensure that the battery SOC is sufficient to maintain normal operation when the system is off-grid, the battery will purchase electricity from the grid and charge to the set SOC protection value when the system is connected to the grid.
9	Discharge Depth (Off-grid)	The maximum discharge value allowed for the battery when the inverter is in the off-grid scenario.
10	Off-grid SOC Recovery	When the inverter is operating off-grid, if the battery SOC drops below the lower limit, the inverter stops outputting power and only charges the battery until the battery SOC returns to the off-grid recovery SOC value. If the SOC lower limit value is higher than the off-grid recovery SOC value, charge to SOC lower limit +10%.
Immediate Charging		
11	Immediate Charging	Enable to charge the battery by the grid immediately. This takes effect once. Enable or Disable based on actual needs.

No.	Parameter	Description
12	SOC for Stopping Charging	Stop charging the battery once the battery SOC reaches SOC For Stopping Charging.
13	Immediate Charging Power	Indicates the percentage of the charging power to the inverter rated power when enabling Immediate Charging. For example, for an inverter with a rated power of 10kW, when set to 60, the charging power is 6kW.
14	Start	Start charging immediately.
15	Stop	Immediately stop the current charging task.

### 7.1.9 Setting Safety Parameters

#### NOTICE

Set the custom safety parameters in compliance with local requirements. Do not change the parameters without the prior consent of the grid company.

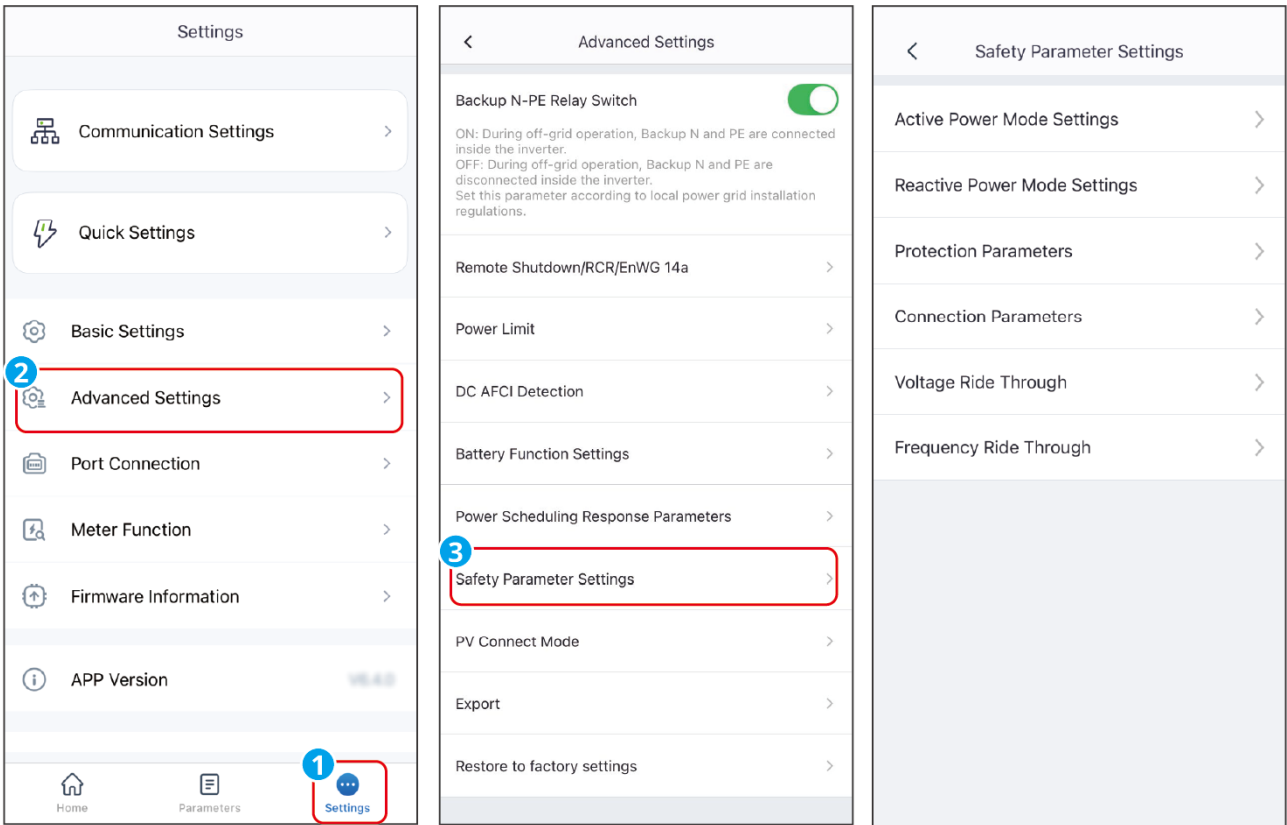

SLG00CON0076

### 7.1.9.1 Setting the Reactive Power Mode

**Step 1 :** Tap Home > Settings > Advanced Settings > Safety Parameter Setting > Reactive Power Mode Settings to set the parameters.

**Step 2 :** Set the parameters based on actual needs.

#### Q(U) Curve

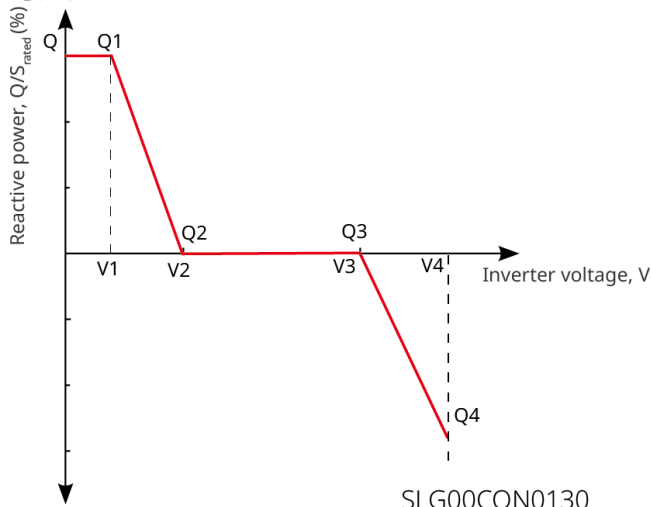

SLG00CON0130

#### Cosφ Curve

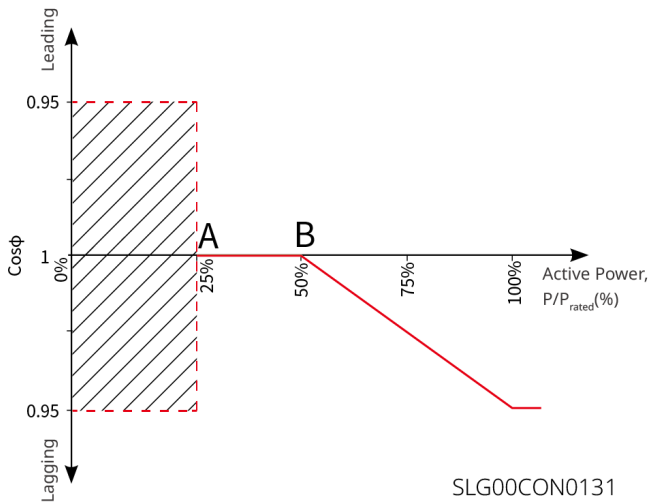

No.	Parameters	Description
Fix PF		
1	Fix PF	Enable Fix PF when it is required by local grid standards and requirements. After the parameters are set successfully, the power factor remains unchanged during the operation of the inverter.
2	Under-excited	Set the power factor as lagging or leading based on actual needs and local grid standards and requirements.
3	Over-excited	
4	Power Factor	Set the power factor based on actual needs. Range: 0~-0.8, or +0.8~+1.
Fix Q		
1	Fix Q	Enable Fix Q when it is required by local grid standards and requirements.
2	Over-excited/Under-excited	Set the reactive power as inductive or capacitive reactive power based on actual needs and local grid standards and requirements.
3	Reactive Power	Set the ratio of reactive power to apparent power.
Q(U) Curve		
1	Q(U) Curve	Enable Q(U) Curve when it is required by local grid standards and requirements.

No.	Parameters	Description
2	Mode Selection	Set Q(U) curve mode, supporting basic mode and slope mode.
3	Vn Voltage	The percentage of actual voltage to the rated voltage at Vn point, n=1, 2, 3, 4. When set to 90, it means: $V/V_{rated}\% = 90\%$ .
4	Vn Reactive Power	The percentage of the reactive output power to the apparent power at Vn point, n=1, 2, 3, 4. For example, setting <b>Vn Reactive Power</b> to 48.5 means $Q/S_{rated}\%=48.5\%$ .
5	Voltage Deadband Width	When Q(U) curve mode is set to slope mode, this parameter defines the voltage deadband range where no reactive power output is required.
6	Over-excitation Slope	(In Q(U) slope mode) Sets the positive or negative slope for reactive power variation during over-voltage conditions.
7	Under-excitation Slope	
8	Vn Reactive Power	The percentage of the reactive output power to the apparent power at Vn point, n=1, 2, 3, 4. For example, setting <b>Vn Reactive Power</b> to 48.5 means $Q/S_{rated}\%=48.5\%$ .
9	Q(U) Curve Response Time Constant	The reactive power must reach 95% of the target value within 3 time constants, following a first-order low-pass filter curve.
10	Extended Function	Enable the extended function and configure the corresponding parameters.
11	Lock-In Power	When the inverter output reactive power to the rated power ratio is between the Lock-in power and Lock-out power, the ratio meets Q(U) curve requirements.
12	Lock-out Power	
Cosφ(P) Curve		

No.	Parameters	Description
1	Cos $\phi$ (P) Curve	Enable Cos $\phi$ Curve when it is required by local grid standards and requirements.
2	Mode Selection	Set cos $\phi$ (P) Curve Mode and support basic mode and slope mode configurations.
3	N-point Power	The percentage of inverter output active power relative to rated power at the N-point. N=A, B, C, D, E.
4	N-point cos $\phi$ Value	N-point Power Factor N=A, B, C, D, E.
5	Over-excitation Slope	When cos $\phi$ (P) curve mode is set to slope mode, configures the power variation slope as either positive or negative.
6	Under-excitation Slope	
7	N-point Power	The percentage of inverter output active power relative to rated power at the N-point. N=A, B, C.
8	N-point cos $\phi$ Value	N-point Power Factor N=A, B, C.
9	cos $\phi$ (P) Curve Response Time Constant	The reactive power must reach 95% of the target value within 3 time constants, following a first-order low-pass filter curve.
10	Extended Function	Enable the extended function and configure the corresponding parameters.
11	Lock-in Voltage	When the grid voltage is between Lock-in Voltage and Lock-out Voltage, the voltage meets Cos $\phi$ curve requirements.
12	Lock-out Voltage	
Q(P) Curve		
1	Q(P) Curve Function	Enable Q(P) Curve when it is required by local grid standards and requirements.
2	Mode Selection	Set Q(P) curve mode, supporting basic mode and slope mode.

No.	Parameters	Description
3	Pn-point Power	The percentage of the output reactive power to the rated power at Pn point, n=1, 2, 3, 4, 5, 6. For example, setting to 90 means $Q/P_{rated}\%=90\%$ .
4	Pn-point Reactive Power	The percentage of the output active power to the rated power at Pn point, n=1, 2, 3, 4, 5, 6. For example, When set to 90, it means: $P/P_{rated}\% = 90\%$ .
5	Over-excitation Slope	When the Q(P) curve mode is set to slope mode, configure the power variation slope as either a positive or negative value.
6	Under-excitation Slope	
7	Pn-point Power	Ratio of reactive power to rated power at Pn points (n=1, 2, 3). For example, setting to 90 means $Q/P_{rated}\%=90\%$ .
8	Pn-point Reactive Power	Ratio of active power to rated power at Pn points (n=1, 2, 3). For example, When set to 90, it means: $P/P_{rated}\% = 90\%$ .
9	Time Constant	The reactive power must reach 95% of the target value within 3 time constants, following a first-order low-pass filter curve.

### 7.1.9.2 Setting the Active Power Mode

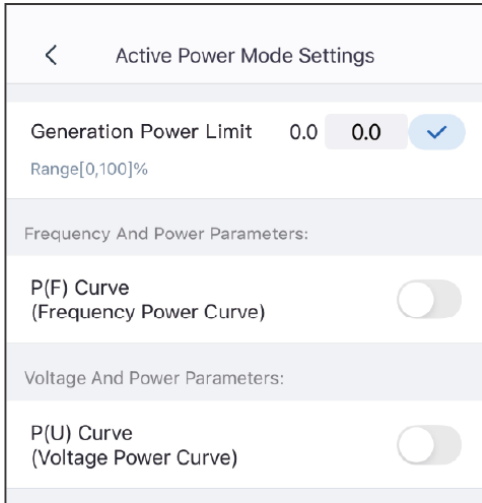

SLG00CON0149

**Step 1:** Tap **Home > Settings > Advanced Settings > Safety Parameter Settings > Active Power Mode Settings** to set the parameters.

**Step 2:** Set the parameters based on actual needs.

### P(F) Curve

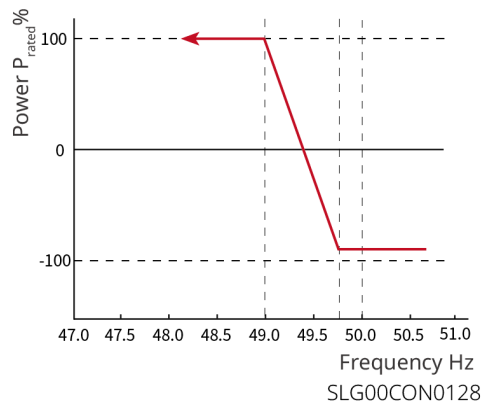
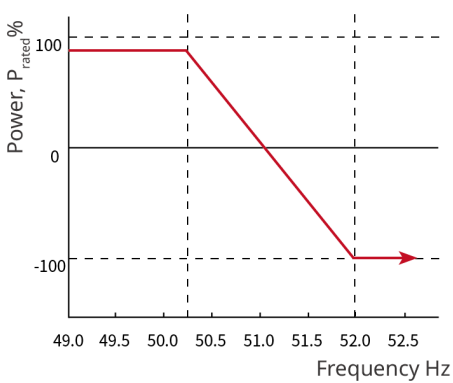

SLG00CON0128

### P(U) Curve

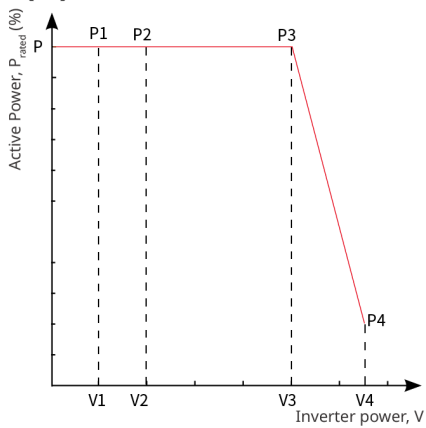

SLG00CON0129

No.	Parameters	Explanation
1	Generation Power Limit	Set the change slope when the active output power increases or decreases.
2	Power Gradient	Set the active power change slope.
Overfrequency Unloading		
1	P(F) Curve	Enable P(F) Curve when it is required by local grid standards and requirements.
2	Over-Frequency Load Shedding Mode	Set the overfrequency unloading mode based on actual needs. <ul style="list-style-type: none"> <li>• Slope mode: adjusts power based on the over frequency point and load reduction slope.</li> <li>• Stop mode: adjusts the power based on the over-frequency start point and over-frequency end point.</li> </ul>
3	Overfrequency Threshold	The inverter output active power will decrease when the utility grid frequency is too high. The inverter output power will decrease when the utility grid frequency is higher than <b>Overfrequency Threshold</b> .
4	Import/Export Electricity Conversion Frequency	When the set frequency value is reached, the system switches from selling electricity to buying electricity.
5	Overfrequency Endpoint	The inverter output active power will decrease when the utility grid frequency is too high. The inverter output power will stop decreasing when the utility grid frequency is higher than <b>Overfrequency Endpoint</b> .

No.	Parameters	Explanation
6	Over-Frequency Power Slope Reference Power	Adjust the inverter output power based on Apparent Active Power, Rated Active Power, Momentary Active Power, Or Max. Active Power.
7	Power response to overfrequency gradient	The inverter output active power will increase when the utility grid frequency is too high. Indicates the slope when the inverter output power decreases.
8	Tentential Delay Ta	Indicates the delayed response time when the inverter output power is higher than the <b>Overfrequency Threshold</b> .
9	Hysteretic Function	Enable the hysteretic function.
10	Frequency Hysteresis Point	During over-frequency load reduction, if the frequency decreases, the power output is based on the lowest point of the load reduction power until the frequency is less than the hysteresis point and the power is restored.
11	Hysteresis Waiting Time	For over-frequency load reduction and frequency decrease, when the frequency is less than the hysteresis point, the power recovery waiting time, that is, it takes a certain amount of time to recover the power.
12	Hysteresis Power Recovery Slope Reference Power	For over-frequency load reduction and frequency decrease, when the frequency is less than the hysteresis point, the power recovery benchmark, that is, the power recovery is based on the recovery slope * the rate of change of the reference power. Support: Pn rated power, Ps apparent power, Pm current power, Pmax maximum power, power difference ( $\Delta P$ ).

No.	Parameters	Explanation
13	Hysteretic Power Recovery Slope	For over-frequency load reduction and frequency reduction, when the frequency is less than the hysteresis point, the power change slope when the power is restored.
Underfrequency Loading		
1	P(F) Curve	Enable P(F) Curve when it is required by local grid standards and requirements.
2	Underfrequency Load Mode	Set the underfrequency unloading mode based on actual needs. <ul style="list-style-type: none"> <li>• Slope mode: adjusts power based on the underfrequency point and load increase slope.</li> <li>• Stop mode: adjusts the power based on the underfrequency start point and underfrequency end point.</li> </ul>
3	Underfrequency Threshold	The inverter output active power will increase when the utility grid frequency is too low. The inverter output power will increase when the utility grid frequency is lower than <b>Underfrequency Threshold</b> .
4	Import/Export Electricity Conversion Frequency	When the set frequency value is reached, the system switches from selling electricity to buying electricity.
5	Underfrequency Endpoint	The inverter output active power will increase when the utility grid frequency is too low. The inverter output power will stop increasing when the utility grid frequency is lower than <b>Underfrequency Endpoint</b> .

No.	Parameters	Explanation
6	Over-Frequency Power Slope Reference Power	Adjust the inverter output power based on Apparent Active Power, Rated Active Power, Momentary Active Power, Or Max. Active Power.
7	Under-Frequency Power Slope	The inverter output active power will increase when the utility grid frequency is too low. The slope of the inverter output power when it rises.
8	Tentional Delay Ta	Indicates the delayed response time when the inverter output power is lower than the <b>Underfrequency Threshold</b> .
9	Hysteretic Function	Enable the hysteretic function.
10	Frequency Hysteresis Point	During underfrequency loading, if the frequency increases, the power is output according to the lowest point of the loaded power until the frequency is higher than the hysteresis point and the power is restored.
11	Hysteresis Waiting Time	For underfrequency loading, the frequency increases, when the frequency is higher than the hysteresis point, the waiting time for power recovery, that is, it takes a certain amount of time to recover the power.
12	Hysteresis Power Recovery Slope Reference Power	For underfrequency loading, the frequency increases, when the frequency is higher than the hysteresis point, the benchmark for power recovery, that is, the power recovery is carried out according to the recovery slope * the rate of change of the benchmark power. Support: Pn rated power, Ps apparent power, Pm current power, Pmax maximum power, power difference ( $\Delta P$ ).

No.	Parameters	Explanation
13	Hysteretic Power Recovery Slope	For under-frequency loading, frequency increase, when the frequency is higher than the hysteresis point, the power change slope when power is restored.
14	P(U) Curve	Enable P(U) Curve when it is required by local grid standards and requirements.
15	Vn Voltage	The percentage of actual voltage to the rated voltage at Vn point, n= 1, 2, 3, 4. For example, setting Vn Voltage to 90 means $V/V_{rated}\%=90\%$ .
16	Vn Active Power	The percentage of the output active power to the apparent power at Vn point, (n= 1, 2, 3, 4). For example, setting <b>Vn Reactive Power</b> to 48.5 means $P/P_{rated}\%=48.5\%$ .
17	Output Response Mode	Set the active power output response mode. Supports: <ul style="list-style-type: none"> <li>• PT-1 Behavior, realize active scheduling based on the first-order LPF curve within the response time constant.</li> <li>• Gradient Control, realize active scheduling based on the power change slope.</li> </ul>
18	Power Gradient	When the output response mode is set to Gradient Control, active power scheduling is achieved according to the power change gradient.
19	First-order Low-pass Filter Time Parameter	Set the time constant within which the active power changes based on the first order LPF curve when the Output Response Mode is set to be First-order Low-pass Filter Time Parameter.
20	Overload Function Switch	When enabled, the maximum active power output is 1.1 times the rated power; otherwise, the maximum active power output is consistent with the rated power value.

### 7.1.9.3 Setting Protection Parameters

**Step 1 :** Tap **Home > Settings > Advanced Settings > Safety Parameter Settings >**

**Protection Parameters** to set the parameters.

**Step 2:** Set the parameters based on actual needs.

No.	Parameters	Description
1	OV Stage n Trip Value	Set the grid overvoltage protection threshold value, n=1,2,3,4.
2	OV Stage n Trip Time	Set the grid overvoltage protection tripping time, n=1,2,3,4.
3	UV Stage n Trip Value	Set the grid undervoltage protection threshold value, n=1,2,3,4.
4	UV Stage n Trip Time	Set the grid undervoltage protection tripping time.
5	10min Overvoltage Trip Threshold	Set the 10min overvoltage protection threshold value.
6	10min Overvoltage Trip Time	Set the 10min overvoltage protection tripping time.
7	OF Stage n Trip Value	Set the grid overfrequency triggering n-th order protection point, n=1,2,3,4.
8	OF Stage n Trip Time	Set the grid overfrequency trigger n-th order trip time, n=1,2,3,4.
9	UF Stage n Trip Value	Set the grid underfrequency triggering n-th order protection point, n=1,2,3,4.
10	UF Stage n Trip Time	Set the grid underfrequency trigger n-th order trip time, n=1,2,3,4.

#### 7.1.9.4 Setting Connection Parameters

**Step 1 :** Tap **Home > Settings > Advanced Settings > Safety Parameter Settings > Protection Parameters** to set the parameters.

**Step 2:** Set the parameters based on actual needs.

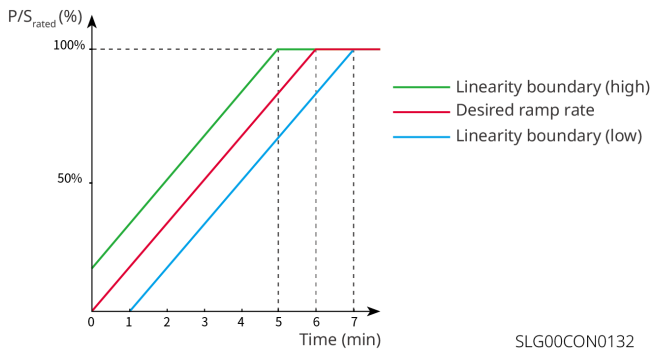

No.	Parameters	Description
Ramp Up		
1	Upper Voltage	The inverter cannot connect to the grid if it is powered on for the first connection and the grid voltage is higher than the <b>Upper Voltage</b> .
2	Lower Voltage	The inverter cannot connect to the grid if it is powered on for the first connection and the grid voltage is lower than the <b>Lower Voltage</b> .
3	Upper Frequency	The inverter cannot connect to the grid if it is powered on for the first connection and the grid frequency is higher than the <b>Upper Frequency</b> .
4	Lower Frequency	The inverter cannot connect to the grid if it is powered on for the first connection and the grid frequency is lower than the <b>Lower Frequency</b> .
5	Observation Time	The waiting time for connecting the inverter to the grid when meeting the following requirements. 1. The inverter is powered on for the first connection. 2. The utility grid voltage and frequency meet certain requirements.
6	Soft Ramp Up Gradient	Enable the start up power slope.
7	Soft Ramp Up Gradient	Indicates the percentage of incremental output power per minute based on the local requirements when the inverter is powered on for the first time.
Reconnection		

No.	Parameters	Description
8	Upper Voltage	The inverter cannot connect to the grid if it is reconnecting due to a fault and the grid voltage is higher than the <b>Upper Voltage</b> .
9	Lower Voltage	The inverter cannot connect to the grid if it is reconnecting due to a fault and the grid voltage is lower than the <b>Lower Voltage</b> .
10	Upper Frequency	The inverter cannot connect to the grid if it is reconnecting due to a fault and the grid frequency is higher than the <b>Upper Frequency</b> .
11	Lower Frequency	The inverter cannot connect to the grid if it is reconnecting due to a fault and the grid frequency is lower than the <b>Lower Frequency</b> .
12	Observation Time	The waiting time for connecting the inverter to the grid when meeting the following requirements. 1. The inverter is reconnecting to the grid due to a fault. 2. The utility grid voltage and frequency meet certain requirements.
13	Reconnection Gradient	Enable the start up power slope.
14	Reconnection Gradient	Indicates the percentage of incremental output power per minute based on the local requirements when the inverter is powered on for the first time. For example, setting Reconnection Gradient to 10 means the reconnect slope is 10%P/Srated/min.

#### 7.1.9.5 Setting Voltage Ride Through Parameters

**Step 1** : Tap **Home** > **Settings** > **Advanced Settings** > **Safety Parameter Settings** > **Voltage Ride Through** to set the parameters.

**Step 2** : Set the parameters based on actual needs.

No.	Parameters	Description
LVRT		
1	UVn Voltage	The ratio of the ride through voltage to the rated voltage at UVn point during LVRT. n=1,2,3,4,5,6,7。
2	UVn Time	The ride through time at UVn point during LVRT. n=1,2,3,4,5,6,7
3	Enter Into LVRT Threshold	The inverter will not be disconnected from the utility grid immediately when the grid voltage is between Enter Into LVRT Threshold and Exit LVRT Endpoint.
4	Exit LVRT Endpoint	
5	Slope K2	K-factor for reactive power during LVRT.
6	Zero Current Mode	The system outputs zero current during LVRT.
7	Entry Threshold	Set the entry threshold of zero current mode.
HVRT		
1	OVn Voltage	The ratio of the ride through voltage to the rated voltage at OVn point during HVRT. n=1,2,3,4,5,6,7。
2	OVn Time	The ride through time at OVn point during HVRT. n=1,2,3,4,5,6,7。
3	Enter High Crossing Threshold	The inverter will not be disconnected from the utility grid immediately when the grid voltage is between Enter High Crossing Threshold and Exit High Crossing Threshold.
4	Exit High Crossing Threshold	
5	Slope K2	K-factor for reactive power during HVRT.

No.	Parameters	Description
6	Zero Current Mode	The system outputs zero current during HVRT.
7	Entry Threshold	Set the entry threshold of zero current mode.

### 7.1.9.6 Setting Frequency Ride Through Parameters

**Step 1 :** Tap **Home > Settings > Advanced Settings > Safety Parameter Settings > Frequency Ride Through** to set the parameters.

**Step 2 :** Set the parameters based on actual needs.

No.	Parameters	Description
1	UFn Frequency	The frequency at the UFn point during frequency ride through.
2	UFn Frequency	The frequency at the UFn point during frequency ride through. n=1,2,3.
3	UFn Time	The ride through duration at the UFn point during frequency ride through. n=1,2,3.
4	OFn Frequency	The frequency at the OFn point during frequency ride through. n=1,2,3.
5	OFn Time	The ride through duration at the OFn point during frequency ride through. n=1,2,3.

### 7.1.10 Exporting Parameters

#### 7.1.10.1 Exporting Safety Parameters

After selecting the safety code, some models support exporting safety parameter files.

**Step 1 :** Tap **Home > Settings > Advanced Settings > Export** to export the parameters.

**Step 2 :** Select Safety Parameters, and tap **Export** to start downloading the current safety parameter file. When the export is complete, tap **Share** and choose how you want to open the exported file.

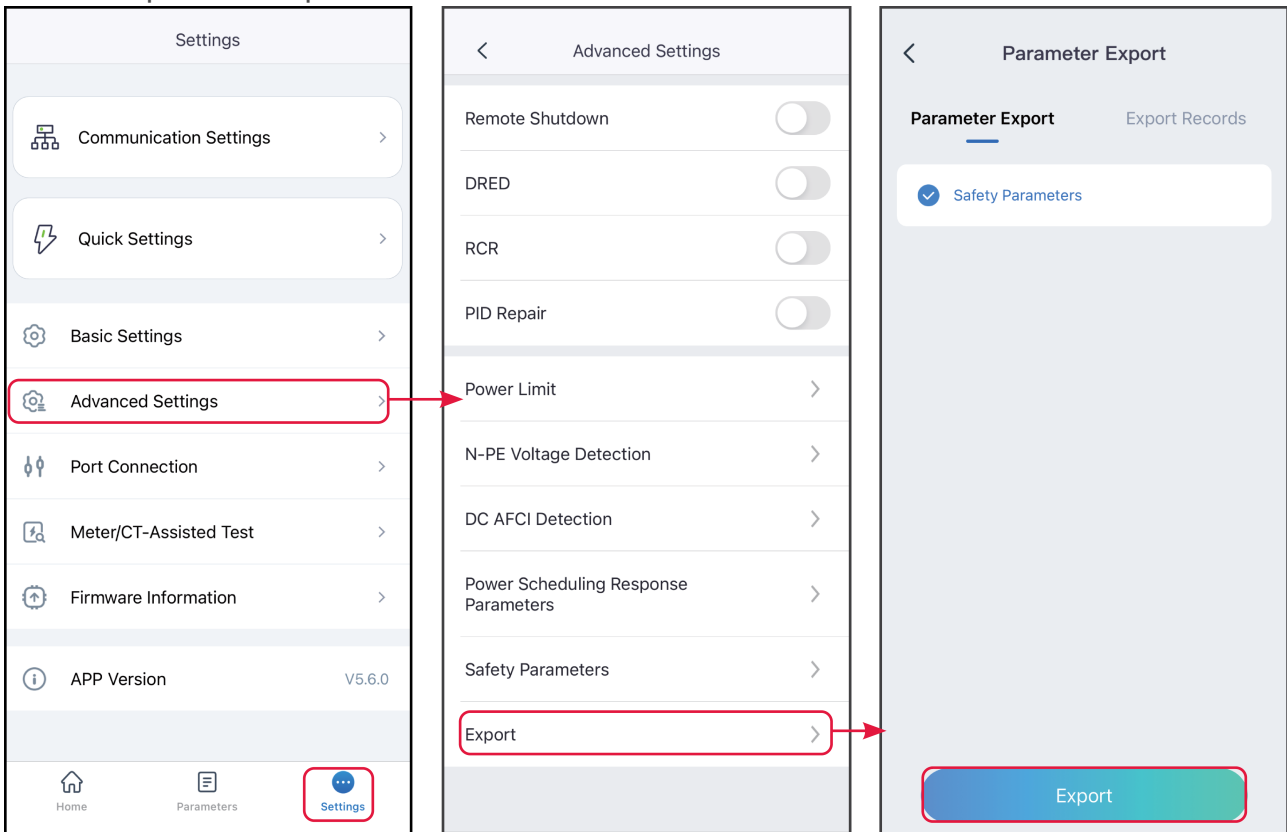

### 7.1.10.2 Exporting Log Parameters

**Step 1 :** Tap **Home > Settings > Advanced Settings > Export**.

**Step 2 :** Select the device type to export logs, such as inverter logs, communication module logs, etc.

**Step 3:** Select the log type to export, download and export the log file. After the export is complete, tap **Share** and choose how to open the exported file according to actual needs.

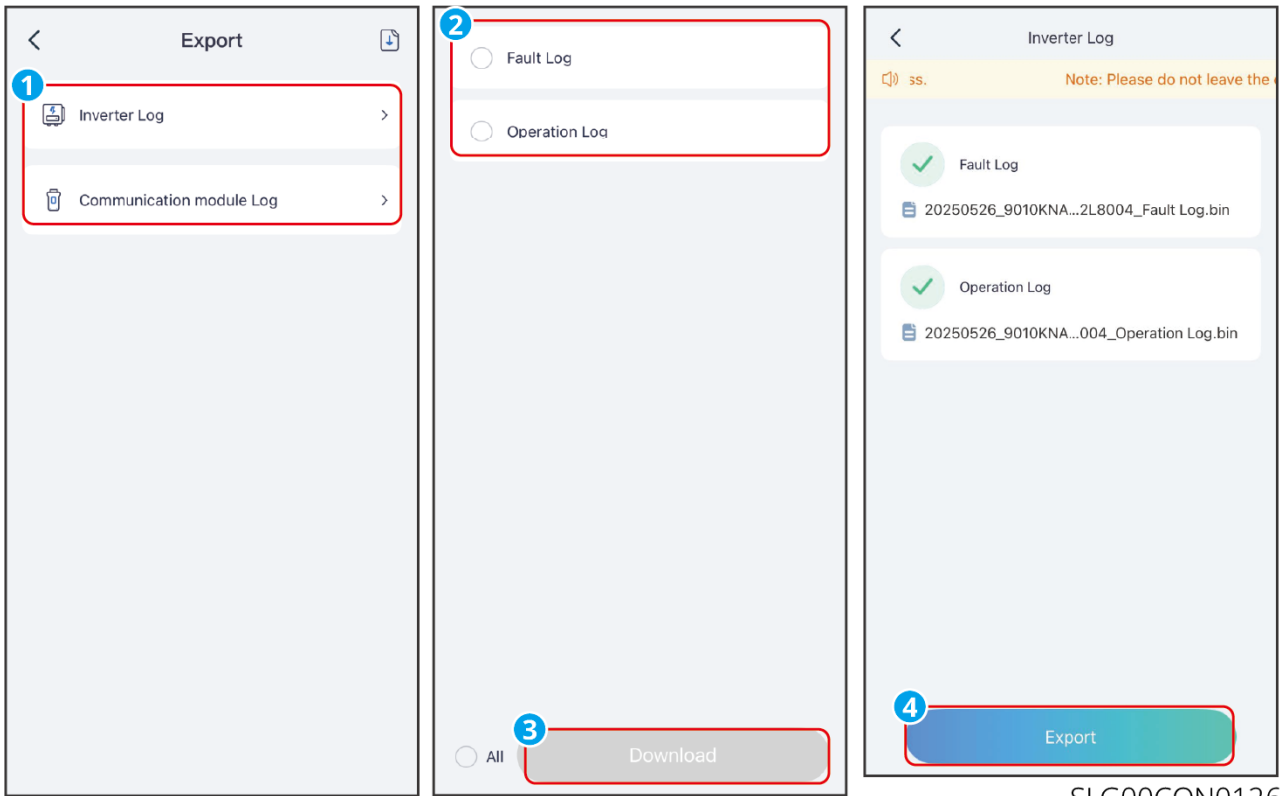

SLG00CON0126

## 7.1.11 Setting Generator/Load Control

### 7.1.11.1 Setting Load Control

#### NOTICE

- Loads and generators can be controlled by SolarGo app when the inverter supports load control function.
- For ET40-50kW series inverters, the load control function is supported only when the inverter is used with STS. The inverter supports load control of the GENERATOR port or the BACKUP LOAD port.

**Step 1:** Tap **Home > Settings > Port Connection** to set the parameters.

**Step 2:** Select **Generator Control** or **Load Control** based on actual needs.

- **Dry Contact Mode:** when the switch is ON, the loads will be powered; when the switch is OFF, the power will be cut off. Turn on or off the switch based on actual

needs.

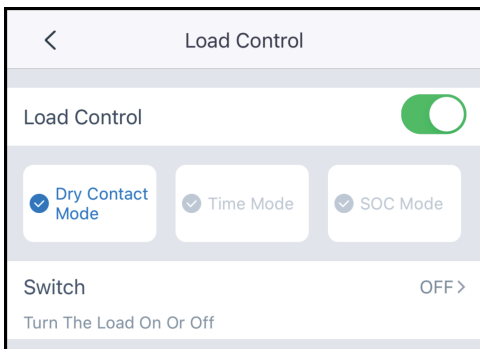

- Time Mode: set the time to enable the load, and the load will be powered automatically within the setting time period. Select standard mode or intelligent mode.

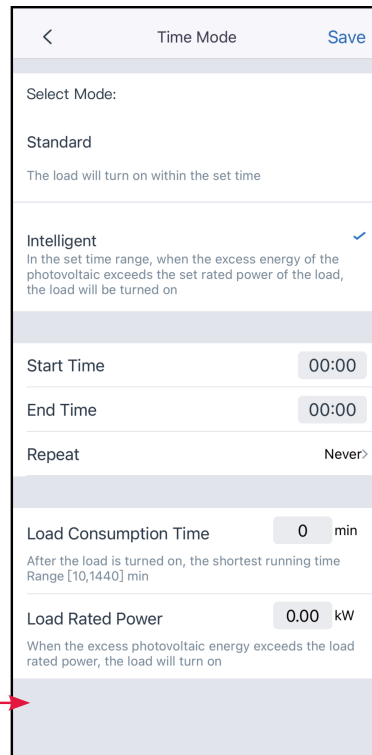
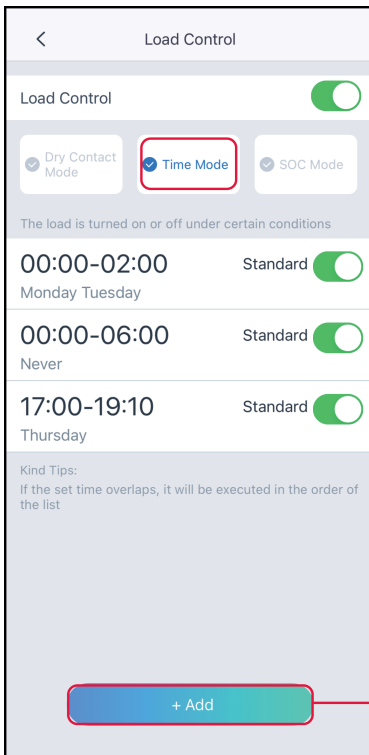

No.	Parameters	Description
1	Standard	The loads will be powered within the setting time period.
2	Intelligent	Once the excess energy of the photovoltaic exceeds the load nominal power within the time period, the loads will be powered.

No.	Parameters	Description
3	Start Time	The time mode will be on between the Start Time and End Time.
4	End Time	
5	Repeat	The repeat days.
6	Load Consumption Time	The shortest load working time after the loads been powered. The time is set to prevent the loads be turned on and off frequently when the PV power fluctuates greatly. Only for Intelligent mode.
7	Load Rated Power	The loads will be powered when the excess energy of the photovoltaic exceeds the nominal power of load. Only for Intelligent mode.

- SOC Mode: the inverter has integrated dry contact controlling port, which can control whether the load is powered or not by contactor. In off-grid mode, the load connected to the port will not be powered if the BACKUP overload is detected or the battery SOC value is lower than the Off-grid battery protection value. Set Off-grid Battery Protection Value based on actual needs.

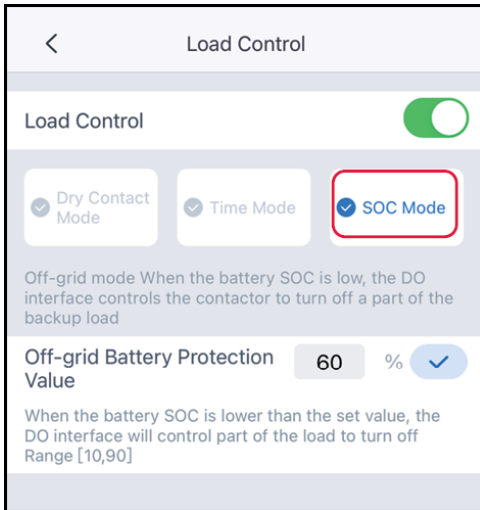

### 7.1.11.2 Setting the Generator Parameters

## NOTICE

- When the inverter supports the generator control function, the generator can be controlled through the SolarGo App.
- For ET40-50kW series inverters, the generator can be connected and controlled only when the inverter is used with STS.

**Step 1** : Tap **Home > Settings > Port Connection** to set the parameters.

**Step 2**: Select Generator Connection or Load Connection based on actual needs.

**Step 3** : When setting the generator control function, select the generator type according to the actual access situation. Currently supported:**Not Installed, Manual Control Of Generator** or **Automatic Control Generator**. And set the parameters according to the selected generator type.

- Not Installed: If no generator is connected in the system, select Not Installed.
- Manual Control Of Generator(Doesn't Support Dry Node Connection): Start or stop the generator manually. The inverter cannot control the generator when Manual Control Of Generator(Doesn't Support Dry Node Connection) is selected.
- Automatic control generator (Supports dry node connection): If the generator has dry contact port and is connected to the inverter, set the generator control mode to Switch Control Mode or Automatic Control Mode based on actual needs.
  - Switch Control Mode: The generator will start working when the Generator Dry Node Switch is on, and stop automatically after reaching Run Time.
  - Automatic Control Mode: The generator will work during Run Time, but stop working during Prohibited Working Hours.

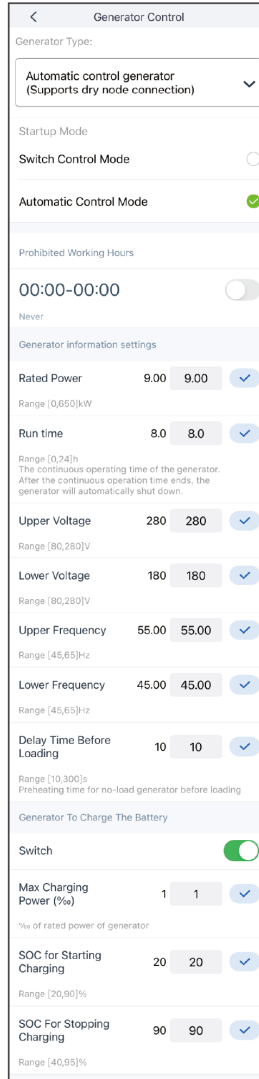
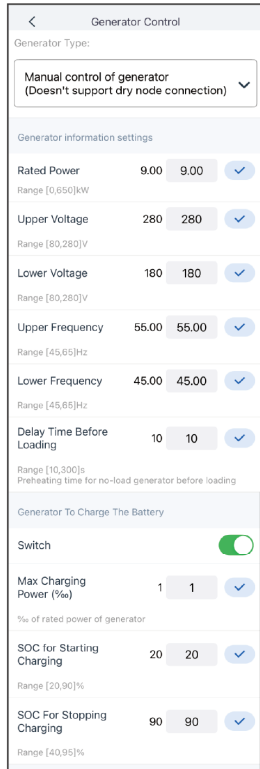
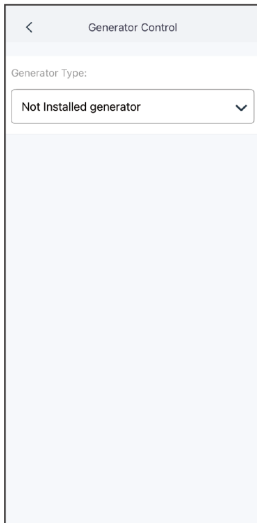

SLG00CON0079

No.	Parameters	Description
1	Startup Mode	Switch Control Mode/Automatic Control Mode
Switch Control Mode		
2	Generator Dry Node Switch	Only for Switch Control Mode.
3	Run Time	Set the generator's continuous runtime, after which the generator will be turned off.
Automatic Control Mode		
4	Prohibited Working Hours	Set the time period during which the generator cannot work.

No.	Parameters	Description
5	Run Time	Set the generator's continuous runtime, after which the generator will be turned off. If the generator start-up operation time includes prohibited working time, the generator will stop running during this time period; after the prohibited working time, the generator will restart running and timing.

No.	Parameters	Description
Generator Information Settings		
1	Rated Power	Set the rated power of the generator.
2	Run Time	Set the continuous running time of the generator. The generator will be shut down after the continuous running time ends.
3	Upper Voltage	Set the operation voltage range of the generator.
4	Lower Voltage	
5	Frequency Cap	Set the operation frequency range of the generator.
6	Lower Frequency	
7	Preheating time	Set the generator no-load preheating time.
Parameter settings for generator charging batteries		
8	Switch	Select whether to use the generator to generate electricity to charge the battery.
9	Max.charging power (%)	The charging power when the generator generates electricity to charge the battery.
10	Start charging SOC	When the battery SOC is lower than this value, the generator generates electricity to charge the battery.
11	Stop charging SOC	When the battery SOC is higher than this value, stop charging the battery.

### 7.1.12 Setting the Meter Parameters

### 7.1.12.1 Bind/Unbind Meter

#### NOTICE

- When the PV system uses both the grid-connected inverter and the energy storage inverter to achieve coupling or microgrid functions, dual meters may be used in the system. Please set the meter binding information according to the actual usage.
- Applicable only to GoodWe meters.

**Step 1 :** Tap **Home > Settings > Meter Function > Meter Binding** to enter the binding interface.

**Step 2 :** Tap **Quantity/Location of Meters** to select the actual application scenario. Supported options: Meter 1 (built-in) No Meter 2; Meter 1 (external) No Meter 2; Meter 1 (built-in) Meter 2 (external); Meter 1 (external) Meter 2 (external). the interface of Meter 1 (built-in) Meter 2 (external) is used as an example to explain how to bind the meter.

**Step 3 :** As shown in the figure below, when you choose to use an external meter, you need to manually add the external meter information. Tap  to bind the meter by manually entering the meter SN or scanning the meter SN QR code. When the bound meter model is GM330, please set the meter CT ratio according to the actual situation and click ✓ to complete the setting. If you use other meters, you do not need to set the meter CT ratio.

**Step 4 :** (Optional) If you need to unbind the external meter, please tap **Remove Binding**.

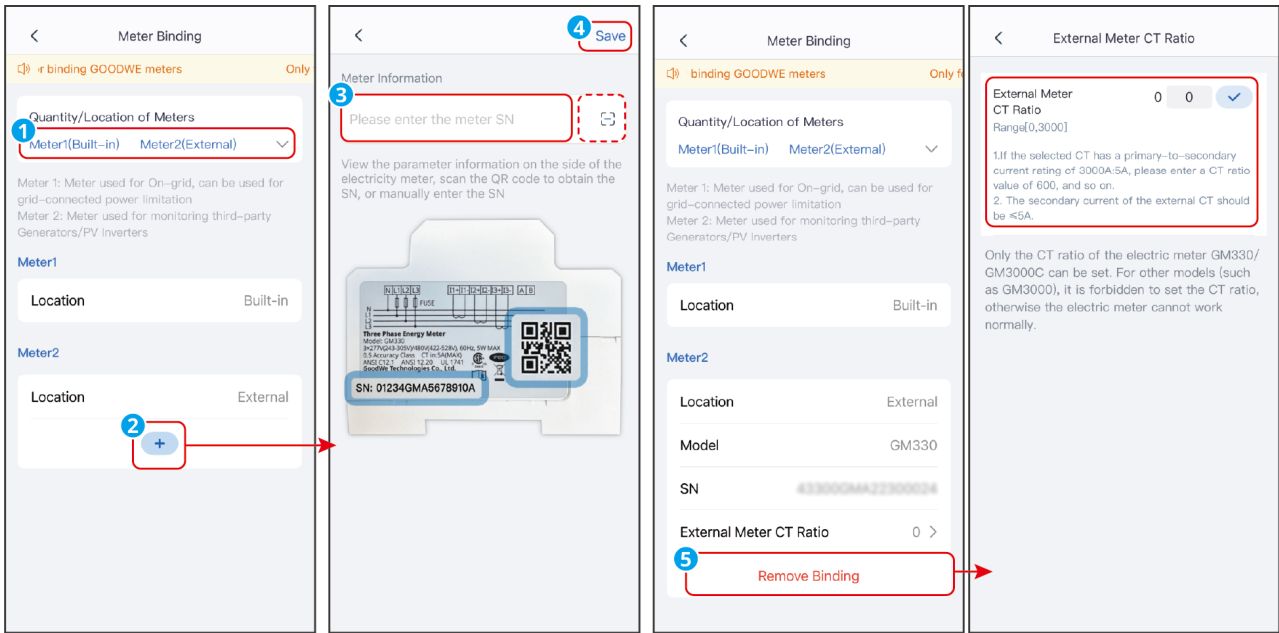

SLG00CON0123

### 7.1.12.2 Meter/CT-Assisted Test

Meter/CT-Assisted Test is used to auto-check if the Smart Meter and CT are connected in the right way and their working status.

**Step 1 :** Tap **Home > Settings > Meter/CT Assisted Test** to set the function.

**Step 2 :** Tap **Start Test** to start test. Check Test Result after test.

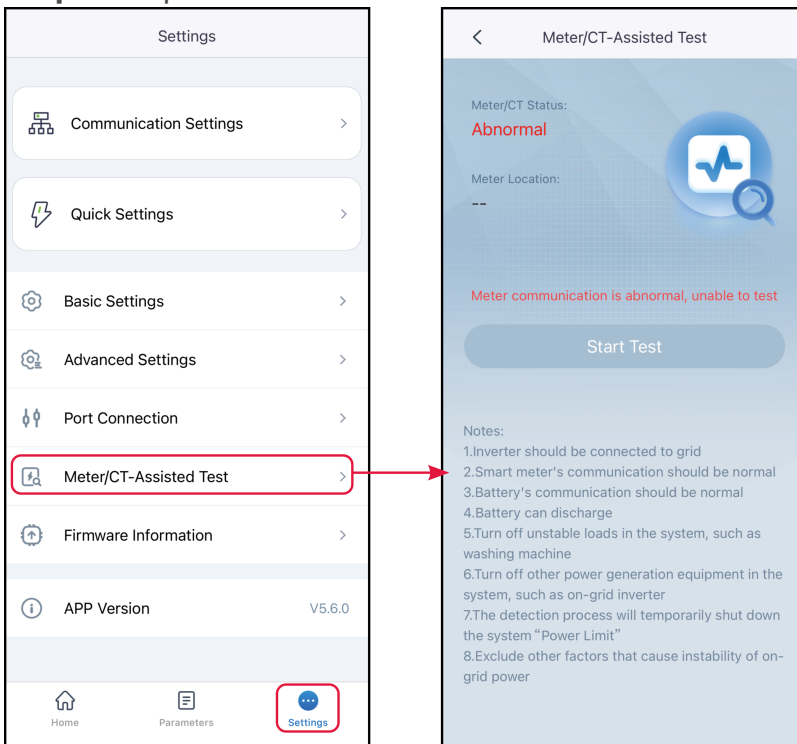

## 7.1.13 Equipment Maintenance

### 7.1.13.1 Checking Firmware Information/Upgrading Firmware Version

Upgrade the DSP version, ARM version, BMS version, AFCI version, or STS version of the inverter, or firmware version of the communication module. Some devices do not support upgrading the firmware version through SolarGo app.

#### NOTICE

If the Firmware Upgrade dialog box pops up once logging into the app, click Firmware Upgrade to directly go to the firmware information page.

#### 7.1.13.1.1 Regular Upgrade

#### NOTICE

- When there is a red dot on the right side of the firmware information, please click to view the firmware update information.
- During the upgrade process, please ensure that the network is stable and the device is connected to SolarGo, otherwise the upgrade may fail.

**Step 1 :** Tap **Home > Settings > Firmware Information** to check the firmware version. If the firmware upgrade dialog box pops up, tap **Firmware Upgrade** and turn to the upgrade interface.

**Step 2 :** (Optional) Tap **Check For Update** to confirm whether the latest firmware version is available for updating.

**Step 3:** Tap **Firmware Upgrade** to enter the firmware upgrade interface.

**Step 4 :** (Optional) Tap **Learn More** to view firmware-related information, such as the current version, the latest version, firmware update records, etc.

**Step 5 :** Tap **Upgrade** and complete the upgrade according to the prompts on the interface.

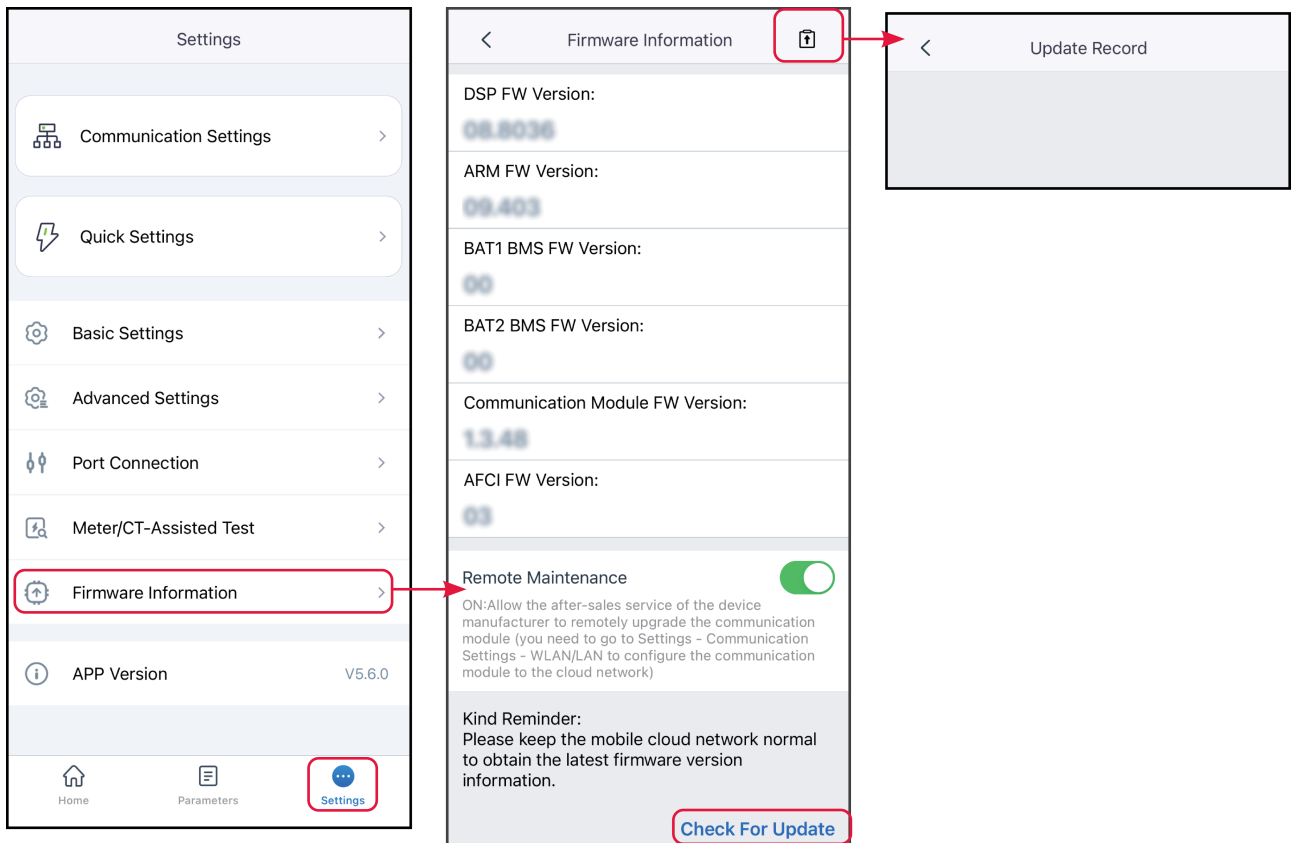

### 7.1.13.1.2 One-click Upgrade

NOTICE

- When there is a red dot on the right side of the firmware information, please click to view the firmware update information.
- During the upgrade process, please ensure that the network is stable and the device is connected to SolarGo, otherwise the upgrade may fail.

**Step 1** : Tap **Home** > **Settings** > **Firmware Information**. Tap **Firmware Information** as prompted to enter the firmware upgrade page.

**Step 2** : Tap **Upgrade** and follow the prompts to complete the upgrading. If you only need to upgrade a specific firmware version, tap **Learn More** to check the firmware related information and tap **Firmware Upgrade** below the firmware version you want to upgrade, and follow the on-screen prompts to complete the operation.

**Step 3** : Tap **Learn More** to view all current firmware version information.

**Step 4**: (Optional) Tap ,to view the version upgrade record.

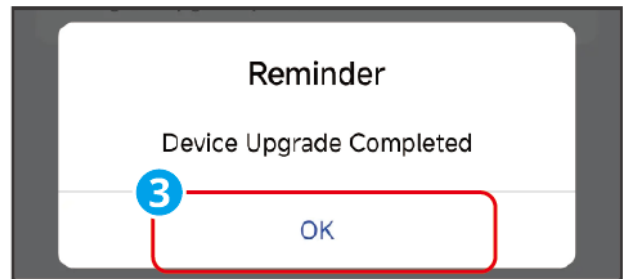
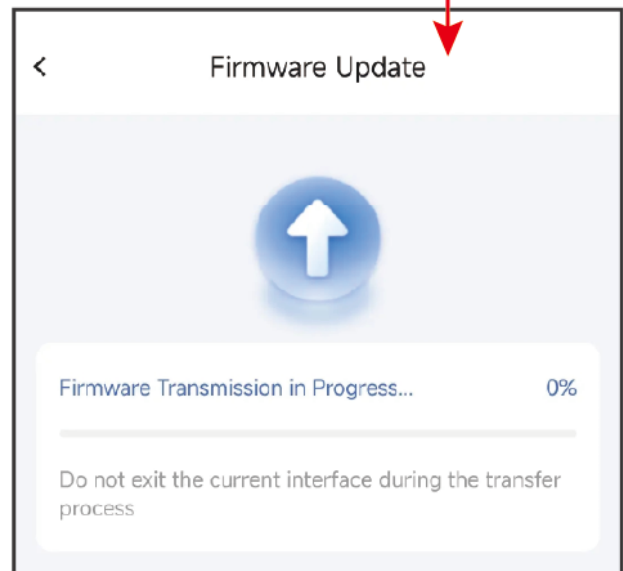
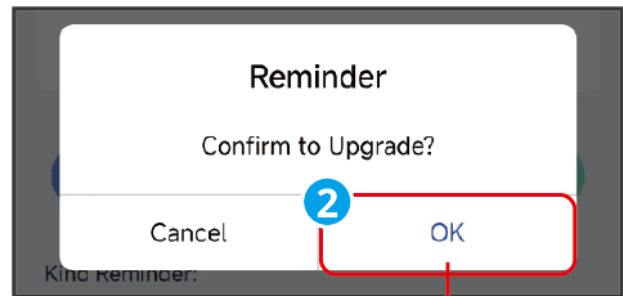
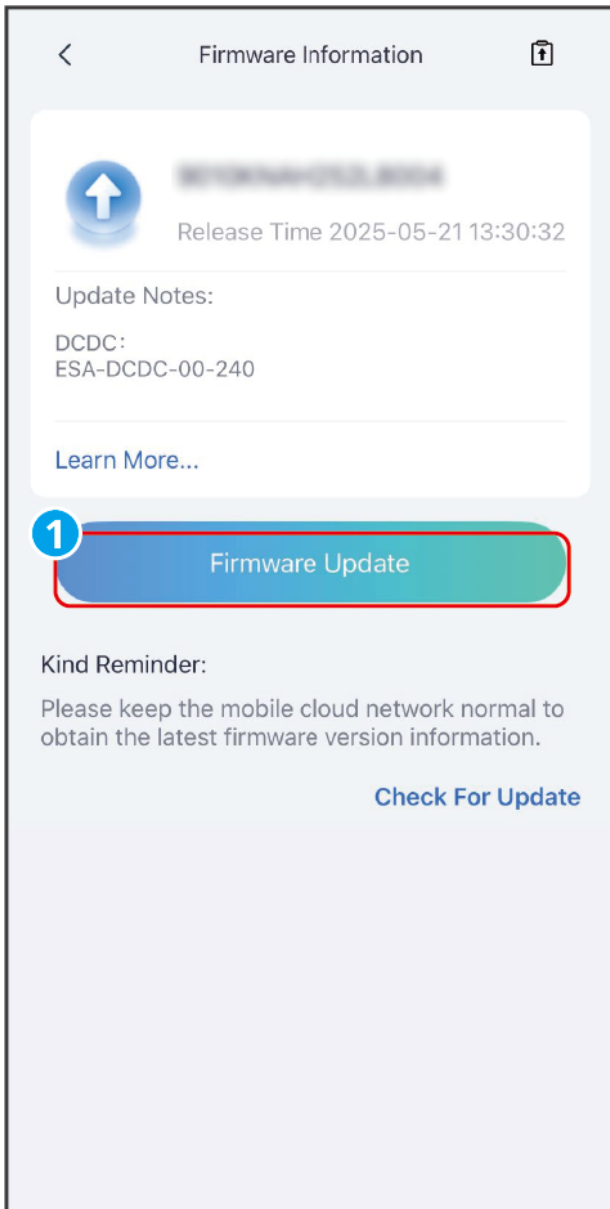

SLG00CON0127

### 7.1.13.1.3 Automatic Upgrade

## NOTICE

- When using WiFi/LAN Kit-20 or WiFi Kit-20 module communication and the module firmware version is V2.0.1 or above, the device automatic upgrade function can be enabled.
- After the device automatic upgrade function is enabled, if the module version is updated and the device has been connected to the network, the corresponding firmware version can be automatically upgraded.

**Step 1 :** Tap **Home > Settings > Firmware Information.**

**Step 2 :** Enable or disable the automatic device upgrade function according to actual needs.

### 7.1.13.1.4 Checking Firmware Information

**Step 1:** Tap **Parameters > Firmware Version** to check the version information.



SLG00CON0191

### 7.1.13.2 Change the Login Password

#### NOTICE

The login password can be changed. Keep the changed password in mind after changing it. Contact the after-sales service if you forget the password.

**Step 1 :** Tap **Home > Settings > Change Login Password** to change the password.

**Step 2 :** Change the password based on actual needs.

< Change Login Password Save

Please enter the new password 

Please enter new password again 

Note: 8-16 characters, need a combination of numbers and uppercase or lowercase letters (0-9, a-z, A-Z)

SLG00CON0088

# 8 System Commissioning and Power Plant Monitoring

## 8.1 Setting Inverter Parameters via App

SEMS+ App is a software used for remote power plant monitoring or local device debugging. It supports installers or owners in:

- Remotely monitoring the power plant operation and setting the operating parameters for the plant and equipment.
- Locally connecting to devices to view their operating status and set device parameters.

For detailed functions, please refer to the [《SEMS+ App User Manual》](#). The user manual can be obtained from the official website or by scanning the QR code below.



SEMS+ App User Manual

### 8.1.1 Download and Install SEMS+ App

#### Mobile Requirements:

- Operating System Requirements: Android 7.0 and above, iOS 15.1 and above.
- The mobile phone must support a web browser and connect to the Internet.
- The mobile phone must support WLAN/Bluetooth functionality.

#### Download Methods:

##### Method 1:

Search for SEMS+ in Google Play, App Store, Huawei, Honor, Xiaomi, OPPO, and vivo

app stores to download and install.



### Method 2:

Scan the QR code below to download and install.



## 8.2 Monitoring Power Plants via SEMS+ WEB

SEMS+ WEB is a monitoring platform that can communicate via WiFi or LAN. The following are the common functions of SEMS+ WEB:

1. Manage organization or user information, etc.
2. Add and monitor power plant information, etc.
3. Maintain equipment.

For detailed functions, please refer to the ["SEMS+ WEB User Manual"](#).



SEMS+ WEB User Manual

# 9 Maintenance

## 9.1 Power OFF the System

### DANGER

- When performing operation and maintenance on devices in the system, please power off the system. Operating devices with power on may cause device damage or electric shock DANGER.
- After the device is powered off, the internal components require some time to discharge. Please wait until the device is completely discharged according to the label time requirements.
- Restarting the battery should be done using the air switch power-on method.
- When shutting down the battery system, please strictly adhere to the battery system power-off requirements to prevent damage to the battery system.
- When there are multiple batteries in the system, powering off any one battery can power off all batteries.

### NOTICE

- The circuit breakers between the inverter and the battery, and between the battery systems, must be installed in accordance with local laws and regulations.
- To ensure effective protection of the battery system, keep the cover plate of the battery system switch closed. The protective cover can automatically close after being opened. If the battery system switch will not be used for an extended period, secure it with screws.

### Power-off Process

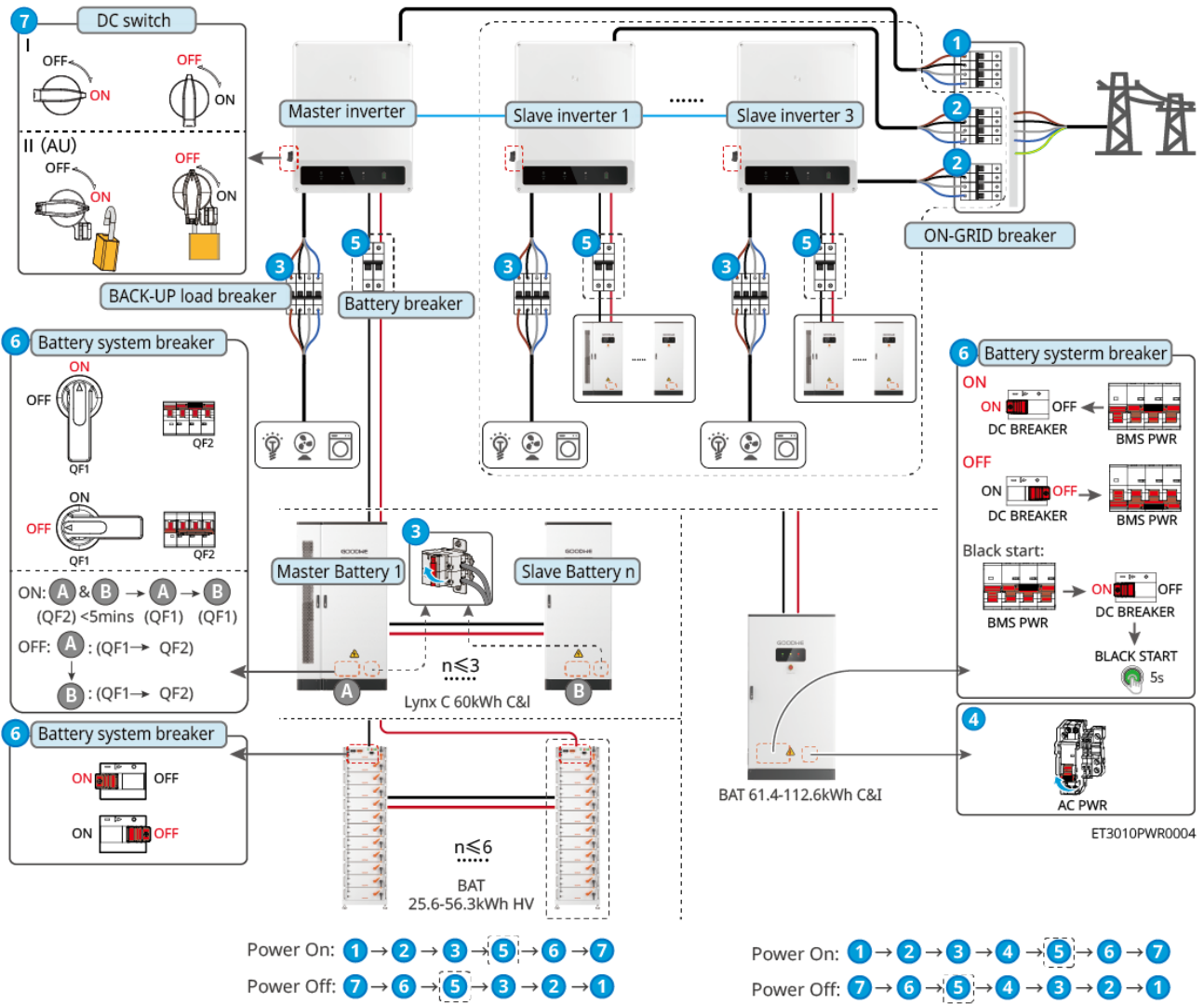

5: Optional according to local laws and regulations.

## 9.2 Removing the Equipment

**DANGER**

- Ensure the device is powered off.
- Wear personal protective equipment when operating the device.
- Use proper disassembly tools when removing wiring terminals to avoid damaging the terminals or the device.
- Unless otherwise specified, the device disassembly method is the reverse order of the installation method, which will not be reiterated in this document.

1. Power down the system.
2. Label all connected cables in the system to indicate their type.
3. Disconnect the cables connected to the Inverter, Battery, and smart meter in the system, such as DC cables, AC cables, Communication cables, and PE cables.
4. Remove devices such as the smart communication stick, Inverter, Battery, and smart meter.
5. Store the equipment properly. If it will be put into use again later, ensure the storage conditions meet the requirements.

## 9.3 Disposing of the Equipment

When the equipment can no longer be used and needs to be disposed of, please dispose of the equipment according to the electrical waste disposal regulations of the country/region where the equipment is located. Do not dispose of the equipment as household waste.

## 9.4 Routine Maintenance

### WARNING

- If any issues are found that may affect the battery or energy storage inverter system, contact after-sales personnel. Disassembly by unauthorized personnel is prohibited.
- If exposed copper wires are found inside the conductive wires, do not touch them due to high voltage danger. Contact after-sales personnel. Disassembly by unauthorized personnel is prohibited.
- In case of other emergencies, contact after-sales personnel immediately. Operate under the guidance of after-sales personnel or wait for them to perform on-site operations.

Maintenance Content	Maintenance Method	Maintenance Cycle	Maintenance Purpose
System Cleaning	Check if there is any foreign matter or dust on the heat sink, fan, and inlet/outlet vents. Check if the installation space meets requirements, and check for any debris accumulation around the equipment.	Once every 6 months	Prevent cooling failures.
System Installation	Check if the equipment installation is secure and if the fastening screws are loose. Check for any damage or deformation on the equipment's exterior.	Once every 6 months to once a year	Confirm equipment installation stability.
Electrical Connections	Check if electrical connections are loose, if cable exteriors are damaged, or if copper wires are exposed.	Once every 6 months to once a year	Confirm electrical connection reliability.
Sealing	Check if the sealing of the equipment's cable entry holes meets requirements. If gaps are too large or unsealed, reseal them.	Once a year	Confirm the machine is sealed and its waterproof performance is intact.
Battery Maintenance	If the battery has not been used for a long time or is not fully charged, it is recommended to charge the battery periodically.	Once every 15 days	Protect battery service life.

## 9.5 fault

### 9.5.1 Viewing Fault/Alarms Information

All detailed fault and alarm information for the energy storage system is displayed in the [SolarGo App], [SEMS+ App], and [SEMS+ WEB]. If your product is abnormal and

no related fault information is seen in the [SolarGo App], [SEMS+ App], or [SEMS+ WEB], please contact the after-sales service center.

- SolarGo App

View the energy storage system alarm information via [Home] > [Parameters] > [Alarms].

- SEMS+ App

1. Open the SEMS+ App and log in with any account.
2. View all power station fault information via [power station] > [Alarms].
3. Click on a specific fault name to view the time the fault occurred, possible causes, and solutions.

SEMS+ WEB

- Open SEMS+ WEB and log in with any account.
- On the power station details interface, click [Alarms] to view all alarm information for the current power station.

## 9.5.2 Fault Information and Troubleshooting

Please perform troubleshooting according to the following methods. If the troubleshooting methods cannot help you, please contact the after-sales service center.

When contacting the after-sales service center, please collect the following information to facilitate a quick resolution.

1. Product information, such as: serial number, software version, device installation time, fault occurrence time, fault occurrence frequency, etc.
2. Device installation environment, such as: weather conditions, whether components are obstructed, have shadows, etc. It is recommended to provide photos, videos, and other files of the installation environment to assist in problem analysis.
3. Grid conditions.

### 9.5.2.1 System Failure

If the system experiences an issue not listed, or if following the instructions still cannot prevent the problem or abnormality, immediately stop operating the system

and contact your dealer at once.

No.	fault	Resolution
1	Unable to search for the Smart Communication Stick's wireless signal	<ol style="list-style-type: none"> <li>1. Ensure no other devices are connected to the Smart Communication Stick's wireless signal.</li> <li>2. Ensure the App is upgraded to the latest version.</li> <li>3. Ensure the Smart Communication Stick is powered normally, with the blue signal light blinking or steadily lit.</li> <li>4. Ensure the smart device is within the communication range of the Smart Communication Stick.</li> <li>5. Refresh the App device list.</li> <li>6. Restart the inverter.</li> </ol>
2	Unable to connect to the Smart Communication Stick's wireless signal	<ol style="list-style-type: none"> <li>1. Ensure no other devices are connected to the Smart Communication Stick's wireless signal.</li> <li>2. Restart the inverter or the communication stick, then try connecting to the Smart Communication Stick's wireless signal again.</li> <li>3. Ensure Bluetooth encryption pairing is successful.</li> </ol>
3	Unable to find the router SSID	<ol style="list-style-type: none"> <li>1. Place the router closer to the Smart Communication Stick, or add a WiFi repeater to enhance the WiFi signal.</li> <li>2. Reduce the number of devices connected to the router.</li> </ol>
4	After all configurations are completed, the Smart Communication Stick fails to connect to the router	<ol style="list-style-type: none"> <li>1. Restart the inverter.</li> <li>2. Check if the network name, encryption method, and password in the WiFi configuration match those of the router.</li> <li>3. Restart the router.</li> <li>4. Place the router closer to the Smart Communication Stick, or add a WiFi repeater to enhance the WiFi signal.</li> </ol>

No.	fault	Resolution
5	After all configurations are completed, the Smart Communication Stick fails to connect to the server	Restart the router and the inverter.

## 9.5.2.2 Inverter Fault

### 9.5.2.2.1 Troubleshooting (Fault Codes F01-F40)

Fault Code	Fault Name	Fault Cause	Troubleshooting Recommendation
F01	Grid Power Outage	<ol style="list-style-type: none"> <li>1. Grid power outage.</li> <li>2. AC wiring or AC switch is disconnected.</li> </ol>	<ol style="list-style-type: none"> <li>1. The alarm will clear automatically after grid power is restored.</li> <li>2. Check if the AC wiring or AC switch is disconnected.</li> </ol>

Fault Code	Fault Name	Fault Cause	Troubleshooting Recommendation
F02	Grid Overvoltage Protection	Grid voltage is higher than the allowable range, or the duration of high voltage exceeds the high voltage ride-through (HVRT) setpoint.	<ol style="list-style-type: none"> <li>1. If it occurs occasionally, it may be due to a temporary grid anomaly. The inverter will resume normal operation after detecting a normal grid, requiring no manual intervention.</li> <li>2. If it occurs frequently, check if the grid voltage is within the allowable range. If not, contact the local power operator. If it is, also modify the grid overvoltage protection point after obtaining consent from the local power operator.</li> <li>3. If normal operation cannot be restored for a long time, check if the AC-side circuit breaker and output cables are properly connected.</li> </ol>

Fault Code	Fault Name	Fault Cause	Troubleshooting Recommendation
F03	Grid Undervoltage Protection	Grid voltage is lower than the allowable range, or the duration of low voltage exceeds the low voltage ride-through (LVRT) setpoint.	<ol style="list-style-type: none"> <li>1. If it occurs occasionally, it may be due to a temporary grid anomaly. The inverter will resume normal operation after detecting a normal grid, requiring no manual intervention.</li> <li>2. If it occurs frequently, check if the grid voltage is within the allowable range. If not, contact the local power operator. If it is, also modify the grid undervoltage protection point after obtaining consent from the local power operator.</li> <li>3. If normal operation cannot be restored for a long time, check if the AC-side circuit breaker and output cables are properly connected.</li> </ol>

Fault Code	Fault Name	Fault Cause	Troubleshooting Recommendation
F04	Grid Rapid Overvoltage Protection	Abnormal grid voltage detection or extremely high voltage triggering the fault.	<p>1. If it occurs occasionally, it may be due to a temporary grid anomaly. The inverter will resume normal operation after detecting a normal grid, requiring no manual intervention.</p> <p>2. If it occurs frequently, check if the grid voltage is within the allowable range. If not, contact the local power operator. If it is, also modify the grid undervoltage protection point after obtaining consent from the local power operator.</p> <p>3. If normal operation cannot be restored for a long time, check if the AC-side circuit breaker and output cables are properly connected.</p>
F05	10min Overvoltage Protection	The moving average of grid voltage within 10min exceeds the range specified by safety regulations.	Check if the grid voltage is operating at a high level for an extended period. If it occurs frequently, check if the grid frequency is within the allowable range. If not, contact the local power operator. If it is, also modify the grid 10min overvoltage protection point after obtaining consent from the local power operator.

Fault Code	Fault Name	Fault Cause	Troubleshooting Recommendation
F06	Grid Overfrequency	Grid anomaly: The actual grid frequency is higher than the local grid standard requirement.	<p>1. If it occurs occasionally, it may be due to a temporary grid anomaly. The inverter will resume normal operation after detecting a normal grid, requiring no manual intervention.</p> <p>2. If it occurs frequently, check if the grid frequency is within the allowable range. If not, contact the local power operator. If it is, also modify the grid overfrequency protection point after obtaining consent from the local power operator.</p>
F07	Grid Underfrequency	Grid anomaly: The actual grid frequency is lower than the local grid standard requirement.	<p>1. If it occurs occasionally, it may be due to a temporary grid anomaly. The inverter will resume normal operation after detecting a normal grid, requiring no manual intervention.</p> <p>2. If it occurs frequently, check if the grid frequency is within the allowable range. If not, contact the local power operator. If it is, also modify the grid overfrequency protection point after obtaining consent from the local power operator.</p>

Fault Code	Fault Name	Fault Cause	Troubleshooting Recommendation
F08	Grid Frequency Instability	Grid anomaly: The rate of change of the actual grid frequency does not comply with the local grid standard.	<p>1. If it occurs occasionally, it may be due to a temporary grid anomaly. The inverter will resume normal operation after detecting a normal grid, requiring no manual intervention.</p> <p>2. If it occurs frequently, check if the grid frequency is within the allowable range. If not, contact the local power operator.</p>
F09	Anti-islanding Protection	The grid has been disconnected, but grid voltage is maintained due to the presence of loads. Grid connection is stopped according to safety regulation protection requirements.	<p>1. If it occurs occasionally, it may be due to a temporary grid anomaly. The inverter will resume normal operation after detecting a normal grid, requiring no manual intervention.</p> <p>2. If it occurs frequently, check if the grid frequency is within the allowable range. If not, contact the local power operator.</p>
F10	LVRT Undervoltage	Grid anomaly: The duration of abnormal grid voltage exceeds the time specified by the LVRT/HVRT regulations.	<p>1. If it occurs occasionally, it may be due to a temporary grid anomaly. The inverter will resume normal operation after detecting a normal grid, requiring no manual intervention.</p> <p>2. If it occurs frequently, check if the grid voltage and frequency are within the allowable range and stable. If not, contact the local power operator.</p>

Fault Code	Fault Name	Fault Cause	Troubleshooting Recommendation
F11	HVRT Overvoltage	Grid anomaly: The duration of abnormal grid voltage exceeds the time specified by the LVRT/HVRT regulations.	<p>1. If it occurs occasionally, it may be due to a temporary grid anomaly. The inverter will resume normal operation after detecting a normal grid, requiring no manual intervention.</p> <p>2. If it occurs frequently, check if the grid voltage and frequency are within the allowable range and stable. If not, contact the local power operator.</p>
F12	30mA GFCI Protection	The input-to-ground insulation impedance becomes low during inverter operation.	<p>1. If it occurs occasionally, it may be caused by a temporary external wiring anomaly. It will resume normal operation after the fault is cleared, requiring no manual intervention.</p> <p>2. If it occurs frequently or cannot be restored for a long time, check if the PV string's impedance to ground is too low.</p>
F13	60mA GFCI Protection	The input-to-ground insulation impedance becomes low during inverter operation.	<p>1. If it occurs occasionally, it may be caused by a temporary external wiring anomaly. It will resume normal operation after the fault is cleared, requiring no manual intervention.</p> <p>2. If it occurs frequently or cannot be restored for a long time, check if the PV string's impedance to ground is too low.</p>

Fault Code	Fault Name	Fault Cause	Troubleshooting Recommendation
F14	150mA GFCI Protection	The input-to-ground insulation impedance becomes low during inverter operation.	<p>1. If it occurs occasionally, it may be caused by a temporary external wiring anomaly. It will resume normal operation after the fault is cleared, requiring no manual intervention.</p> <p>2. If it occurs frequently or cannot be restored for a long time, check if the PV string's impedance to ground is too low.</p>
F15	GFCI Gradual Change Protection	The input-to-ground insulation impedance becomes low during inverter operation.	<p>1. If it occurs occasionally, it may be caused by a temporary external wiring anomaly. It will resume normal operation after the fault is cleared, requiring no manual intervention.</p> <p>2. If it occurs frequently or cannot be restored for a long time, check if the PV string's impedance to ground is too low.</p>
F16	DCI Level 1 Protection	The DC component of the inverter output current is higher than the range allowed by safety regulations or the machine's default settings.	<p>1. If it is caused by an external fault, the inverter will automatically resume normal operation after the fault disappears, requiring no manual intervention.</p> <p>2. If this alarm occurs frequently, affecting normal power generation of the power station, contact the distributor or after-sales service center.</p>

Fault Code	Fault Name	Fault Cause	Troubleshooting Recommendation
F17	DCI Level 2 Protection	The DC component of the inverter output current is higher than the range allowed by safety regulations or the machine's default settings.	<ol style="list-style-type: none"> <li>1. If it is caused by an external fault, the inverter will automatically resume normal operation after the fault disappears, requiring no manual intervention.</li> <li>2. If this alarm occurs frequently, affecting normal power generation of the power station, contact the distributor or after-sales service center.</li> </ol>

Fault Code	Fault Name	Fault Cause	Troubleshooting Recommendation
F18	Low Insulation Resistance	<ol style="list-style-type: none"> <li>1. PV string shorted to protective earth.</li> <li>2. The PV string installation environment is humid for a long time and the wiring has poor insulation to ground.</li> <li>3. Battery port wiring has low insulation impedance to ground.</li> </ol>	<ol style="list-style-type: none"> <li>1. Check the impedance of the PV string/battery port to protective earth. A value greater than 80kΩ is normal. If the measured value is less than 80kΩ, locate and rectify the short-circuit point.</li> <li>2. Check if the inverter's protective earth wire is correctly connected.</li> <li>3. If it is confirmed that the impedance is indeed below the default value in rainy/overcast conditions, reset the inverter's "Insulation Resistance Protection Point" via the App.</li> </ol> <p>For inverters in the Australian and New Zealand markets, the following additional alarm methods are available when an insulation resistance fault occurs:</p> <ol style="list-style-type: none"> <li>1. The inverter is equipped with a buzzer. When a fault occurs, the buzzer sounds continuously for 1 minute; if the fault is not resolved, the buzzer sounds again every 30 minutes.</li> <li>2. If the inverter is added to a monitoring platform and the alarm notification method is set, alarm information can be sent to the customer via email.</li> </ol>

Fault Code	Fault Name	Fault Cause	Troubleshooting Recommendation
F19	Grounding Abnormal	<ol style="list-style-type: none"> <li>1. The inverter's protective earth wire is not connected.</li> <li>2. When the PV string output is grounded, the inverter output side is not connected to an isolation transformer.</li> </ol>	<ol style="list-style-type: none"> <li>1. Confirm whether the inverter's protective earth wire is properly connected.</li> <li>2. In scenarios where the PV string output is grounded, confirm whether the inverter output side is connected to an isolation transformer.</li> </ol>
F20	Hardware Reverse Power Flow Protection	Load abnormal fluctuation	<ol style="list-style-type: none"> <li>1. If it is caused by an external fault, the inverter will automatically resume normal operation after the fault disappears, requiring no manual intervention.</li> <li>2. If this alarm occurs frequently, affecting normal power generation of the power station, contact the distributor or after-sales service center.</li> </ol>

Fault Code	Fault Name	Fault Cause	Troubleshooting Recommendation
F21	Internal Comm Loss	Sub DSP1 communication timeout - Main DSP, Sub DSP2 communication timeout - Main DSP, Sub DSP2 communication timeout - Sub DSP1, Main DSP communication timeout - Sub DSP1, Main DSP communication timeout - Sub DSP2, or Sub DSP1 communication timeout - Sub DSP2: 1. Chip not powered on. 2. Chip firmware version error.	Disconnect the AC output side switch and DC input side switch, wait for 5 minutes, then close the AC output side switch and DC input side switch. If the fault persists, contact the distributor or after-sales service center.

Fault Code	Fault Name	Fault Cause	Troubleshooting Recommendation
		Main DSP CAN module error, Sub DSP1 CAN module error, or Sub DSP2 CAN module error: 1. Frame format error. 2. Parity check error. 3. CAN bus offline. 4. Hardware CRC check error. 5. Control bit set to receive (transmit) during transmission (reception). 6. Transmission to a disallowed unit.	
F22	Generator Waveform Detection Fault	1. This fault will be displayed continuously when no generator is connected. 2. When the generator is operating, this fault is triggered if it does not comply with generator safety regulations.	
F23	Generator Abnormal Connection		
F24	Generator Voltage Low		
F25	Generator Voltage High		
F26	Generator Frequency Low		

Fault Code	Fault Name	Fault Cause	Troubleshooting Recommendation
F27	Generator Frequency High		<p>1. Ignore this fault if no generator is connected.</p> <p>2. If this fault appears when the generator malfunctions, it is normal. Wait for a period after the generator recovers, and the fault will clear automatically.</p> <p>3. This fault does not affect the normal operation of off-grid mode.</p> <p>4. When both the generator and grid are connected and meet safety regulation requirements, grid priority is given for grid connection, and the system will operate in grid-connected state.</p>
F28	Parallel Unit I/O Self-check Abnormal	Parallel communication cable not securely connected or parallel IO chip damaged.	Check if the parallel communication cable is securely connected, then check if the IO chip is damaged. If yes, replace the IO chip.
F29	Parallel Grid Line Reversed	Some units' grid lines are reversed with others.	Reconnect the grid lines.
F30	AC HCT check Abnormal	AC current sensor has sampling abnormality.	Disconnect the AC output side switch and DC input side switch, wait for 5 minutes, then close the AC output side switch and DC input side switch. If the fault persists, contact the distributor or after-sales service center.

<b>Fault Code</b>	<b>Fault Name</b>	<b>Fault Cause</b>	<b>Troubleshooting Recommendation</b>
F31	GFCI HCT Check Abnormal	Leakage current sensor has sampling abnormality.	Disconnect the AC output side switch and DC input side switch, wait for 5 minutes, then close the AC output side switch and DC input side switch. If the fault persists, contact the distributor or after-sales service center.
F32	Inverter Internal Failure	Inverter has a fault.	Disconnect the AC output side switch and DC input side switch, wait for 5 minutes, then close the AC output side switch and DC input side switch. If the fault persists, contact the distributor or after-sales service center.
F33	Flash Read/Write Error	Possible causes: Flash content changed; Flash lifespan exhausted;	1. Upgrade to the latest firmware version. 2. Contact the distributor or after-sales service center.
F34	AFCI Check Failure	During the arc fault self-check process, the arc fault module did not detect an arc fault as expected.	Disconnect the AC output side switch and DC input side switch, wait for 5 minutes, then close the AC output side switch and DC input side switch. If the fault persists, contact the distributor or after-sales service center.

Fault Code	Fault Name	Fault Cause	Troubleshooting Recommendation
F35	Cabinet Overtemperature	Cabinet temperature is too high, possible causes: 1. Inverter installation location is not ventilated. 2. Ambient temperature is too high. 3. Internal fan operation is abnormal.	1. Check if the ventilation at the inverter installation location is adequate and if the ambient temperature exceeds the maximum allowable ambient temperature range. 2. If ventilation is poor or ambient temperature is too high, improve its ventilation and heat dissipation conditions. 3. If ventilation and ambient temperature are normal, contact the distributor or after-sales service center.

Fault Code	Fault Name	Fault Cause	Troubleshooting Recommendation
F36	Bus Overvoltage	BUS overvoltage, possible causes: 1. PV voltage is too high; 2. Inverter BUS voltage sampling is abnormal; 3. The isolation effect of the dual-split transformer at the inverter's rear end is poor, causing mutual interference when two inverters are connected in parallel, with one inverter reporting DC overvoltage when grid-connected;	Disconnect the AC output side switch and DC input side switch, wait for 5 minutes, then close the AC output side switch and DC input side switch. If the fault persists, contact the distributor or after-sales service center.

Fault Code	Fault Name	Fault Cause	Troubleshooting Recommendation
F37	PV Input Overvoltage	PV input voltage is too high, possible cause: PV array configuration error, too many PV panels connected in series per string, causing the string's open-circuit voltage to be higher than the inverter's maximum operating voltage.	Check the series configuration of the corresponding PV array string to ensure the string's open-circuit voltage is not higher than the inverter's maximum operating voltage. The inverter alarm will clear automatically after the PV array is correctly configured.
F38	PV Persistent Hardware Overcurrent	1. Module configuration is unreasonable. 2. Hardware damage.	Disconnect the AC output side switch and DC input side switch, wait for 5 minutes, then close the AC output side switch and DC input side switch. If the fault persists, contact the distributor or after-sales service center.
F39	PV Persistent Software Overcurrent	1. Module configuration is unreasonable. 2. Hardware damage.	Disconnect the AC output side switch and DC input side switch, wait for 5 minutes, then close the AC output side switch and DC input side switch. If the fault persists, contact the distributor or after-sales service center.

<b>Fault Code</b>	<b>Fault Name</b>	<b>Fault Cause</b>	<b>Troubleshooting Recommendation</b>
F40, F98	String Reversed (String 1-n) n: Determined based on the actual number of inverter strings.	PV string reversed.	Check if the string is reversed.

#### 9.5.2.2.2 Troubleshooting (Fault Code F41-F80)

<b>Fault Code</b>	<b>Fault Name</b>	<b>Fault Cause</b>	<b>Troubleshooting Recommendation</b>
F41	Generator Port Overload	<ol style="list-style-type: none"> <li>1. The off-grid side output exceeds specifications.</li> <li>2. Short circuit on the off-grid side.</li> <li>3. Off-grid terminal voltage is too low.</li> <li>4. When used as a large load port, the large load exceeds specifications.</li> </ol>	Confirm the off-grid side output voltage, current, power, and other data to identify the cause of the issue.

Fault Code	Fault Name	Fault Cause	Troubleshooting Recommendation
F42	DC Arcing Failure (String 1-n) n: Determined by the actual number of inverter strings.	1. DC side connection terminals are loose; 2. DC side connection terminals have poor contact; 3. DC cable core is damaged or has poor contact.	1. After the unit reconnects to the grid, check if the voltage and current of each circuit abnormally decrease to zero; 2. Check if the DC side terminals are securely connected.
F43	Grid Waveform Abnormal	Utility grid abnormality: Anomaly detected in grid voltage triggers the fault.	1. If it occurs occasionally, it may be due to a temporary utility grid abnormality. The inverter will resume normal operation after detecting a normal grid, requiring no manual intervention. 2. If it occurs frequently, please check if the grid voltage and frequency are within the allowable range and stable. If not, contact the local power operator.
F44	Grid Phase Loss	Utility grid abnormality: Single-phase voltage dip in the grid.	1. If it occurs occasionally, it may be due to a temporary utility grid abnormality. The inverter will resume normal operation after detecting a normal grid, requiring no manual intervention. 2. If it occurs frequently, please check if the grid voltage and frequency are within the allowable range and stable. If not, contact the local power operator.

<b>Fault Code</b>	<b>Fault Name</b>	<b>Fault Cause</b>	<b>Troubleshooting Recommendation</b>
F45	Grid Voltage Imbalance	Excessive difference in grid phase voltages.	<p>1. If it occurs occasionally, it may be due to a temporary utility grid abnormality. The inverter will resume normal operation after detecting a normal grid, requiring no manual intervention.</p> <p>2. If it occurs frequently, please check if the grid voltage and frequency are within the allowable range and stable. If not, contact the local power operator.</p>
F46	Grid Phase Sequence Failure	Inverter and grid wiring abnormality: Wiring is not in positive sequence.	<p>1. Check if the inverter and grid wiring are in positive sequence. The fault will automatically disappear after correct wiring (e.g., swapping any two live wires).</p> <p>2. If the fault persists despite correct wiring, contact the dealer or after-sales service center.</p>
F47	Grid Rapid Shutdown Protection	Rapidly shuts down output after detecting a grid power outage condition.	The fault automatically disappears after grid power supply is restored.
F48	Grid Neutral Wire Loss (Split grid)	Neutral wire loss in a split-phase grid.	<p>1. The alarm automatically disappears after grid power supply is restored.</p> <p>2. Check if the AC wiring or AC switch is disconnected.</p>
F49	L-PE Short Circuit	Low impedance or short circuit between output phase line and PE.	Measure the impedance between the output phase line and PE, locate the point with low impedance and repair it.

<b>Fault Code</b>	<b>Fault Name</b>	<b>Fault Cause</b>	<b>Troubleshooting Recommendation</b>
F50	DCV Level 1 Protection	Abnormal load fluctuation.	1. If caused by an external fault, the inverter will automatically resume normal operation after the fault disappears, requiring no manual intervention. 2. If this alarm occurs frequently, affecting normal power plant generation, contact the dealer or after-sales service center.
F51	DCV Level 2 Protection	Abnormal load fluctuation.	
F52	Residual Current (GFCI) Multiple Fault Shutdown	North American safety regulations require manual recovery or waiting 24h after multiple faults, no automatic recovery.	Please check if the PV string-to-ground impedance is too low.
F53	DC Arcing (AFCI) Multiple Fault Shutdown	North American safety regulations require manual recovery or waiting 24h after multiple faults, no automatic recovery.	1. After the unit reconnects to the grid, check if the voltage and current of each circuit abnormally decrease to zero; 2. Check if the DC side terminals are securely connected.
F54	External Communication Link Broken	Communication loss with external devices of the inverter, possibly due to external device power issues, communication protocol mismatch, or unconfigured corresponding external devices.	Determine based on the actual model and enabled detection bits; external devices not supported by certain models will not be detected.

<b>Fault Code</b>	<b>Fault Name</b>	<b>Fault Cause</b>	<b>Troubleshooting Recommendation</b>
F55	Back-up Port Overload Fault	Prevents the inverter from sustained overload output.	Turn off some off-grid loads to reduce the inverter's off-grid output power.
F56	Back-up Port Overvoltage Fault	Prevents inverter output overvoltage from damaging loads.	1. If it occurs occasionally, it may be caused by load switching and requires no manual intervention. 2. If it occurs frequently, contact the dealer or after-sales service center.
F57	External Box Fault	Waiting too long for the Box to switch the relay during grid-to-off-grid transition.	1. Check if the Box is functioning normally; 2. Check if the Box communication wiring is correct;
F58	CT Loss Fault	CT connection wire disconnected (Japanese safety regulation requirement).	Check if the CT wiring is correct;
F59	Parallel CAN Communication Abnormal	Parallel communication cables are not securely connected or some units are offline.	Check if all units are powered on and if the parallel communication cables are securely connected.
F60	Parallel Back-up Connection Reversed	Some units' backup lines are reversed with others.	Reconnect the backup lines.
F61	Inverter Soft Start Failure	Inverter soft start failure during off-grid cold start.	Check if the inverter module is damaged.

<b>Fault Code</b>	<b>Fault Name</b>	<b>Fault Cause</b>	<b>Troubleshooting Recommendation</b>
F62	AC HCT Failure	HCT sensor abnormality exists.	Disconnect the AC output side switch and DC input side switch, wait 5 minutes, then close the AC output side switch and DC input side switch. If the fault persists, contact the dealer or after-sales service center.
F63	GFCI HCT Failure	Residual current sensor abnormality exists.	Disconnect the AC output side switch and DC input side switch, wait 5 minutes, then close the AC output side switch and DC input side switch. If the fault persists, contact the dealer or after-sales service center.
F64	Inverter Internal Failure	Inverter fault exists.	Disconnect the AC output side switch and DC input side switch, wait 5 minutes, then close the AC output side switch and DC input side switch. If the fault persists, contact the dealer or after-sales service center.
F65	AC Terminal Overtemperature	AC terminal temperature is too high, possible causes: 1. Inverter installation location is not ventilated. 2. Ambient temperature is too high. 3. Internal fan operation is abnormal.	1. Check if the inverter installation location has good ventilation and if the ambient temperature exceeds the maximum allowable range. 2. If ventilation is poor or ambient temperature is too high, improve its ventilation and heat dissipation conditions. 3. If both ventilation and ambient temperature are normal, contact the dealer or after-sales service center.

Fault Code	Fault Name	Fault Cause	Troubleshooting Recommendation
F66	INV Module Overtemperature	Inverter module temperature is too high, possible causes: 1. Inverter installation location is not ventilated. 2. Ambient temperature is too high. 3. Internal fan operation is abnormal.	1. Check if the inverter installation location has good ventilation and if the ambient temperature exceeds the maximum allowable range. 2. If ventilation is poor or ambient temperature is too high, improve its ventilation and heat dissipation conditions. 3. If both ventilation and ambient temperature are normal, contact the dealer or after-sales service center.
F67	Boost Module Overtemperature	Boost module temperature is too high, possible causes: 1. Inverter installation location is not ventilated. 2. Ambient temperature is too high. 3. Internal fan operation is abnormal.	1. Check if the inverter installation location has good ventilation and if the ambient temperature exceeds the maximum allowable range. 2. If ventilation is poor or ambient temperature is too high, improve its ventilation and heat dissipation conditions. 3. If both ventilation and ambient temperature are normal, contact the dealer or after-sales service center.

Fault Code	Fault Name	Fault Cause	Troubleshooting Recommendation
F68	AC Capacitor Overtemperature	Output filter capacitor temperature is too high, possible causes: 1. Inverter installation location is not ventilated. 2. Ambient temperature is too high. 3. Internal fan operation is abnormal.	1. Check if the inverter installation location has good ventilation and if the ambient temperature exceeds the maximum allowable range. 2. If ventilation is poor or ambient temperature is too high, improve its ventilation and heat dissipation conditions. 3. If both ventilation and ambient temperature are normal, contact the dealer or after-sales service center.
F69	PV IGBT Short Circuit Fault	Possible causes: 1. IGBT short circuit 2. Inverter sampling circuit abnormality	Disconnect the AC output side switch and DC input side switch, wait 5 minutes, then close the AC output side switch and DC input side switch. If the fault persists, contact the dealer or after-sales service center.
F70	PV IGBT Open Circuit Fault	1. Software issue causing no PWM generation: 2. Drive circuit abnormality: 3. IGBT open circuit	
F71	NTC Abnormal	NTC temperature sensor abnormality.	Disconnect the AC output side switch and DC input side switch, wait 5 minutes, then close the AC output side switch and DC input side switch. If the fault persists, contact the dealer or after-sales service center.

<b>Fault Code</b>	<b>Fault Name</b>	<b>Fault Cause</b>	<b>Troubleshooting Recommendation</b>
F72	PWM Abnormal	PWM abnormal waveform detected.	Disconnect the AC output side switch and DC input side switch, wait 5 minutes, then close the AC output side switch and DC input side switch. If the fault persists, contact the dealer or after-sales service center.
F73	CPU Interrupt Abnormal	CPU interrupt abnormality.	Disconnect the AC output side switch and DC input side switch, wait 5 minutes, then close the AC output side switch and DC input side switch. If the fault persists, contact the dealer or after-sales service center.
F74	Microelectronics Fault	Functional safety detection detected an abnormality.	Disconnect the AC output side switch and DC input side switch, wait 5 minutes, then close the AC output side switch and DC input side switch. If the fault persists, contact the dealer or after-sales service center.
F75	PV HCT Fault	boost current sensor abnormality.	Disconnect the AC output side switch and DC input side switch, wait 5 minutes, then close the AC output side switch and DC input side switch. If the fault persists, contact the dealer or after-sales service center.
F76	1.5V Reference Abnormal	Reference circuit fault.	Disconnect the AC output side switch and DC input side switch, wait 5 minutes, then close the AC output side switch and DC input side switch. If the fault persists, contact the dealer or after-sales service center.
F77	0.3V Reference Abnormal	Reference circuit fault.	
F78	CPLD Version Identification Error	CPLD version identification error.	Disconnect the AC output side switch and DC input side switch, wait 5 minutes, then close the AC output side switch and DC input side switch. If the fault persists, contact the dealer or after-sales service center.

<b>Fault Code</b>	<b>Fault Name</b>	<b>Fault Cause</b>	<b>Troubleshooting Recommendation</b>
F79	CPLD Communication Fault	CPLD and DSP communication content error or timeout.	Disconnect the AC output side switch and DC input side switch, wait 5 minutes, then close the AC output side switch and DC input side switch. If the fault persists, contact the dealer or after-sales service center.
F80	Model Identification Fault	Fault related to model identification error.	Disconnect the AC output side switch and DC input side switch, wait 5 minutes, then close the AC output side switch and DC input side switch. If the fault persists, contact the dealer or after-sales service center.

#### 9.5.2.2.3 Troubleshooting (Fault Codes F81-F121)

<b>Fault Code</b>	<b>Fault Name</b>	<b>Possible Cause</b>	<b>Troubleshooting Suggestions</b>
F81	P-Bus Overvoltage		Disconnect the AC output side switch and the DC input side switch, wait for 5 minutes, then close the AC output side switch and the DC input side switch. If the fault persists, please contact the dealer or after-sales service center.

Fault Code	Fault Name	Possible Cause	Troubleshooting Suggestions
F82	N-Bus Overvoltage	BUS overvoltage, possible causes: 1. PV voltage is too high; 2. Inverter BUS voltage sampling is abnormal; 3. The isolation effect of the dual-split transformer at the inverter's output side is poor, causing mutual interference when two inverters are grid-connected, and one inverter reports DC overvoltage during grid connection;	
F83	Bus Overvoltage (Sub CPU1)		Disconnect the AC output side switch and the DC input side switch, wait for 5 minutes, then close the AC output side switch and the DC input side switch. If the fault persists, please contact the dealer or after-sales service center.
F84	P-Bus Overvoltage (Sub CPU1)		

Fault Code	Fault Name	Possible Cause	Troubleshooting Suggestions
F85	N-Bus Overvoltage (Sub CPU1)	BUS overvoltage, possible causes: 1. PV voltage is too high; 2. Inverter BUS voltage sampling is abnormal; 3. The isolation effect of the dual-split transformer at the inverter's output side is poor, causing mutual interference when two inverters are grid-connected, and one inverter reports DC overvoltage during grid connection;	
F86	Bus Overvoltage (Sub CPU2)		Disconnect the AC output side switch and the DC input side switch, wait for 5 minutes, then close the AC output side switch and the DC input side switch. If the fault persists, please contact the dealer or after-sales service center.
F87	P-Bus Overvoltage (Sub CPU2)		

Fault Code	Fault Name	Possible Cause	Troubleshooting Suggestions
F88	N-Bus Overvoltage (Sub CPU2)	BUS overvoltage, possible causes: 1. PV voltage is too high; 2. Inverter BUS voltage sampling is abnormal; 3. The isolation effect of the dual-split transformer at the inverter's output side is poor, causing mutual interference when two inverters are grid-connected, and one inverter reports DC overvoltage during grid connection;	
F89	P-Bus Overvoltage (CPLD)		Disconnect the AC output side switch and the DC input side switch, wait for 5 minutes, then close the AC output side switch and the DC input side switch. If the fault persists, please contact the dealer or after-sales service center.

Fault Code	Fault Name	Possible Cause	Troubleshooting Suggestions
F90	N-Bus Overvoltage(CPLD)	BUS overvoltage, possible causes: 1. PV voltage is too high; 2. Inverter BUS voltage sampling is abnormal; 3. The isolation effect of the dual-split transformer at the inverter's output side is poor, causing mutual interference when two inverters are grid-connected, and one inverter reports DC overvoltage during grid connection;	
F91	FlyCap Software Overvoltage	FlyCap overvoltage, possible causes: 1. PV voltage is too high; 2. Inverter flycap voltage sampling is abnormal;	Disconnect the AC output side switch and the DC input side switch, wait for 5 minutes, then close the AC output side switch and the DC input side switch. If the fault persists, please contact the dealer or after-sales service center.
F92	FlyCap Hardware Overvoltage		

Fault Code	Fault Name	Possible Cause	Troubleshooting Suggestions
F93	FlyCap Undervoltage	FlyCap undervoltage, possible causes: 1. PV energy is insufficient; 2. Inverter flycap voltage sampling is abnormal;	Disconnect the AC output side switch and the DC input side switch, wait for 5 minutes, then close the AC output side switch and the DC input side switch. If the fault persists, please contact the dealer or after-sales service center.
F94	FlyCap Precharge Failure	FlyCap precharge failure, possible causes: 1. PV energy is insufficient; 2. Inverter flycap voltage sampling is abnormal;	Disconnect the AC output side switch and the DC input side switch, wait for 5 minutes, then close the AC output side switch and the DC input side switch. If the fault persists, please contact the dealer or after-sales service center.
F95	FlyCap Precharge Abnormal	1. Unreasonable control loop parameters 2. Hardware damage	Disconnect the AC output side switch and the DC input side switch, wait for 5 minutes, then close the AC output side switch and the DC input side switch. If the fault persists, please contact the dealer or after-sales service center.

Fault Code	Fault Name	Possible Cause	Troubleshooting Suggestions
F96, F97	String Overcurrent(String1-n) n: Determined based on the actual number of inverter strings	Possible causes: 1. String overcurrent; 2. String current sensor abnormal	Disconnect the AC output side switch and the DC input side switch, wait for 5 minutes, then close the AC output side switch and the DC input side switch. If the fault persists, please contact the dealer or after-sales service center.
F99, F100	String Loss(String1-n) n: Determined based on the actual number of inverter strings	String fuse disconnected (if present)	Check if the fuse is disconnected.
F101	Battery 1 Precharge fault	Battery 1 precharge circuit fault (precharge resistor burned out, etc.)	Check if the precharge circuit is in good condition. After only the battery is powered on, check if the battery voltage and bus voltage are consistent. If not, please contact the dealer or after-sales service center.
F102	Battery 1 Relay Failure	Battery 1 relay cannot operate normally	After the battery is powered on, check if the battery relay is working and if a closing sound is heard. If it does not operate, please contact the dealer or after-sales service center.

<b>Fault Code</b>	<b>Fault Name</b>	<b>Possible Cause</b>	<b>Troubleshooting Suggestions</b>
F103	Battery 1 Connection Overvoltage	Battery 1 connection voltage exceeds the machine's rated range	Confirm if the battery voltage is within the machine's rated range.
F104	Battery 2 Precharge fault	Battery 2 precharge circuit fault (precharge resistor burned out, etc.)	Check if the precharge circuit is in good condition. After only the battery is powered on, check if the battery voltage and bus voltage are consistent. If not, please contact the dealer or after-sales service center.
F105	Battery 2 Relay Failure	Battery 2 relay cannot operate normally	After the battery is powered on, check if the battery relay is working and if a closing sound is heard. If it does not operate, please contact the dealer or after-sales service center.
F106	Battery 2 Connection Overvoltage	Battery 2 connection voltage exceeds the machine's rated range	Confirm if the battery voltage is within the machine's rated range.
F107	On-grid PWM Sync Failure	Abnormal occurred during carrier synchronization grid connection	<ol style="list-style-type: none"> <li>1. Check if the synchronization cable connection is normal</li> <li>2. Check if the master/slave settings are normal;</li> <li>3. Disconnect the AC output side switch and the DC input side switch, wait for 5 minutes, then close the AC output side switch and the DC input side switch. If the fault persists, please contact the dealer or after-sales service center.</li> </ol>
F108	DSP Communication fault	-	-

<b>Fault Code</b>	<b>Fault Name</b>	<b>Possible Cause</b>	<b>Troubleshooting Suggestions</b>
F109	External STS fault	Inverter and STS connection cable abnormal	Check if the wiring sequence of the harness between the inverter and the STS corresponds one-to-one in order.
F110	Export Limit Protection	<ol style="list-style-type: none"> <li>1. Inverter reports error and disconnects from grid</li> <li>2. meter communication is unstable</li> <li>3. Reverse power flow condition occurs</li> </ol>	<ol style="list-style-type: none"> <li>1. Check if there are other error messages from the inverter. If yes, handle them accordingly;</li> <li>2. Check if the meter connection is reliable;</li> <li>3. If this alarm occurs frequently and affects the normal power generation of the power station, please contact the dealer or after-sales service center.</li> </ol>
F111	Bypass Overload	-	-
F112	Black Start Failure	-	-
F113	Offgrid AC Ins Volt High	-	-
F114	Relay Failure2	Relay abnormal, causes: <ol style="list-style-type: none"> <li>1. Relay abnormal (relay short circuit)</li> <li>2. Relay sampling circuit abnormal.</li> <li>3. AC side wiring abnormal (可能存在虚接或短路现象)</li> </ol>	Disconnect the AC output side switch and the DC input side switch, wait for 5 minutes, then close the AC output side switch and the DC input side switch. If the fault persists, please contact the dealer or after-sales service center.
F115	SVG Precharge Disabled	SVG precharge hardware failure	Contact the dealer or after-sales service center.

<b>Fault Code</b>	<b>Fault Name</b>	<b>Possible Cause</b>	<b>Troubleshooting Suggestions</b>
F116	Nighttime SVG PID Prevention fault	PID prevention hardware abnormal	
F117	DSP Version Identification Error	DSP software version identification error	Disconnect the AC output side switch and the DC input side switch, wait for 5 minutes, then close the AC output side switch and the DC input side switch. If the fault persists, please contact the dealer or after-sales service center.
F118	MOS Continuous Overvoltage	<ol style="list-style-type: none"> <li>1. Software issue causing inverter drive to turn off earlier than flyback drive;</li> <li>2. Inverter drive circuit abnormal causing failure to turn on;</li> <li>3. PV voltage is too high;</li> <li>4. Mos voltage sampling abnormal;</li> </ol>	Disconnect the AC output side switch and the DC input side switch, wait for 5 minutes, then close the AC output side switch and the DC input side switch. If the fault persists, please contact the dealer or after-sales service center.
F119	Bus Short Circuit fault	Hardware damage	If the inverter remains disconnected from the grid after a BUS short circuit fault occurs, please contact the dealer or after-sales service center.

Fault Code	Fault Name	Possible Cause	Troubleshooting Suggestions
F120	Bus Sampling Abnormal	1. BUS voltage sampling hardware fault	Disconnect the AC output side switch and the DC input side switch, wait for 5 minutes, then close the AC output side switch and the DC input side switch. If the fault persists, please contact the dealer or after-sales service center.
F121	DC Side Sampling Abnormal	1. BUS voltage sampling hardware fault 2. Battery voltage sampling hardware fault 3. Dcrlly relay fault	Disconnect the AC output side switch and the DC input side switch, wait for 5 minutes, then close the AC output side switch and the DC input side switch. If the fault persists, please contact the dealer or after-sales service center.

Fault Code	Fault Name	Possible Cause	Troubleshooting Suggestions
F122	PV Access Mode Setting Error	<p>There are three PV access modes.</p> <p>Taking four MPPTs as an example:</p> <p>1. Parallel mode: i.e., AAAA mode (same-source mode), PV1-PV4 are from the same source, all 4 PV strings are connected to the same photovoltaic panel.</p> <p>2. Partial parallel mode: i.e., AACC mode, PV1 and PV2 are from the same source and connected together, PV3 and PV4 are from the same source and connected together.</p> <p>3. Independent mode: i.e., ABCD mode (non-same-source), PV1, PV2, PV3, PV4 are independently connected, each of the 4 PV strings is connected to one</p>	<p>Check if the PV access mode is set correctly (ABCD, AACC, AAAA). Reset the PV access mode correctly.</p> <p>1. Confirm if each PV string is correctly connected in practice;</p> <p>2. If the PV strings are correctly connected, check the currently set "PV Access Mode" via the APP or screen to see if it corresponds to the actual access mode;</p> <p>3. If the currently set "PV Access Mode" does not match the actual access mode, use the APP or screen to set the "PV Access Mode" to the mode consistent with the actual situation. After setting, disconnect the PV and AC power supply and restart;</p> <p>4. After setting, if the current "PV Access Mode" matches the actual access mode but this fault is still reported, please contact the dealer or after-sales service center.</p>

Fault Code	Fault Name	Possible Cause	Troubleshooting Suggestions
		photovoltaic panel. This fault is reported if the actual PV access mode does not match the PV access mode set in the device.	

**9.5.2.2.4 Troubleshooting (Fault Codes F122-F163)**

Fault Code	Fault Name	Possible Cause	Troubleshooting Recommendations
F123	Multi-channel PV Phase Error	PV Input Mode Setting Error	<p>Check if the PV Access Mode is set correctly (ABCD, AACC, AAAA). Reset the PV Access Mode correctly.</p> <ol style="list-style-type: none"> <li>1. Confirm that each actual PV channel is correctly connected.</li> <li>2. If the PV is correctly connected, check via the APP or screen whether the currently set "PV Access Mode" corresponds to the actual connection mode.</li> <li>3. If the currently set "PV Access Mode" does not match the actual connection mode, use the APP or screen to set the "PV Access Mode" to the mode consistent with the actual situation. After setting, disconnect and restart the PV and AC power supply.</li> <li>4. After setting, if the current "PV Access Mode" matches the actual connection mode but this fault still occurs, please contact the dealer or after-sales service center.</li> </ol>
F124	Battery 1 Reverse Connection fault	Battery 1 positive and negative terminals are reversed	Check if the polarity of the battery terminals matches that of the machine's terminals.
F125	Battery 2 Reverse Connection fault	Battery 2 positive and negative terminals are reversed	Check if the polarity of the battery terminals matches that of the machine's terminals.

<b>Fault Code</b>	<b>Fault Name</b>	<b>Possible Cause</b>	<b>Troubleshooting Recommendations</b>
F126	Battery Abnormal Connection	Battery abnormal connection	Check if the battery is working normally.
F127	BAT Overtemperature	Battery temperature is too high. Possible causes: 1. Poor ventilation at the inverter installation location. 2. Ambient temperature is too high. 3. Internal fan operation is abnormal.	Disconnect the AC output side switch and DC input side switch. After 5 minutes, close the AC output side switch and DC input side switch. If the fault persists, please contact the dealer or after-sales service center.
F128	Ref Voltage Abnormal	Reference circuit fault	Disconnect the AC output side switch and DC input side switch. After 5 minutes, close the AC output side switch and DC input side switch. If the fault persists, please contact the dealer or after-sales service center.
F129	Cabinet Under Temperature	Cabinet temperature is too low. Possible cause: Ambient temperature is too low.	Disconnect the AC output side switch and DC input side switch. After 5 minutes, close the AC output side switch and DC input side switch. If the fault persists, please contact the dealer or after-sales service center.
F130	AC Side SPD fault	AC side surge protective device failure	Replace the AC side surge protective device.
F131	DC Side SPD fault	DC side surge protective device failure	Replace the DC side surge protective device.

Fault Code	Fault Name	Possible Cause	Troubleshooting Recommendations
F132	Internal Fan Abnormal	Internal fan abnormal. Possible causes: 1. Abnormal fan power supply. 2. Mechanical fault (stall). 3. Fan aging or damage.	Disconnect the AC output side switch and DC input side switch. After 5 minutes, close the AC output side switch and DC input side switch. If the fault persists, please contact the dealer or after-sales service center.
F133	External Fan Abnormal	External fan abnormal. Possible causes: 1. Abnormal fan power supply. 2. Mechanical fault (stall). 3. Fan aging or damage.	
F134	PID Diagnosis Abnormal	PID hardware fault or PV voltage too high causing PID suspension	No action required for PID suspension warning caused by high PV voltage. For PID hardware fault, clear the PID fault by turning the PID switch off and then on, and replace the PID device.

Fault Code	Fault Name	Possible Cause	Troubleshooting Recommendations
F135	Trip-Switch Trip Warning	Possible causes: Overcurrent or PV reverse connection causing the trip-switch to open.	Contact the dealer or after-sales service center. The cause of tripping is a PV short circuit or reverse connection. Check if there is a historical PV short circuit warning or historical PV reverse connection warning. If present, maintenance personnel need to check the corresponding PV condition. After checking and confirming no fault, you can manually close the trip-switch and clear this warning via the APP interface by clearing historical faults.
F136	Historical PV IGBT Short Circuit Warning	Possible causes: Overcurrent causing the trip-switch to open.	Contact the dealer or after-sales service center. Maintenance personnel need to check the Boost hardware and external string for faults according to the historical PV short circuit warning subcode. After checking and confirming no fault, you can clear this warning via the APP interface by clearing historical faults.

Fault Code	Fault Name	Possible Cause	Troubleshooting Recommendations
F137 , F138	Historical PV Reverse Connection Warning (String 1-n) (n: determined by the actual number of inverter strings)	Possible causes: PV reverse connection causing the trip-switch to open.	Contact the dealer or after-sales service center. Maintenance personnel need to check if the corresponding string has a reverse connection according to the historical PV reverse connection warning subcode, and check if there is a voltage difference in the PV panel configuration. After checking and confirming no fault, you can clear this warning via the APP interface by clearing historical faults.
F139	Flash Read/Write Error Warning	Possible causes: 1. Flash content changed. 2. Flash lifespan exhausted.	1. Upgrade to the latest firmware. 2. Contact the dealer or after-sales service center.
F140	Meter Comm Loss	This warning may only occur when anti-reverse flow function is enabled. Possible causes: 1. Meter not connected. 2. Incorrect wiring of the communication cable between the meter and the inverter.	Check the meter wiring and connect the meter correctly. If the fault persists after checking, please contact the dealer or after-sales service center.
F141	PV Panel Type Identification Failed	PV panel identification hardware abnormal	Contact the dealer or after-sales service center.

<b>Fault Code</b>	<b>Fault Name</b>	<b>Possible Cause</b>	<b>Troubleshooting Recommendations</b>
F142	PV String Mismatch	PV string mismatch, different open-circuit voltage configurations for two strings under the same MPPT	Check the open-circuit voltages of the two strings. Configure strings with the same open-circuit voltage under the same MPPT. Prolonged string mismatch poses safety risks.
F143	CT Not Connected	CT not connected	Check the CT wiring.
F144	CT Reverse Connection	CT reverse connection	Check the CT wiring.
F145	PE Loss	Ground wire not connected	Check the ground wire.
F146	String Terminal High Temperature (String 1~8)	Register 37176 PV terminal temperature alarm subcode 1 is set	-
F147	String Terminal High Temperature (String 9~16)	Register 37177 PV terminal temperature alarm subcode 2 is set	-
F148	String Terminal High Temperature (String 17~20)	Register 37178 PV terminal temperature alarm subcode 3 is set	-

<b>Fault Code</b>	<b>Fault Name</b>	<b>Possible Cause</b>	<b>Troubleshooting Recommendations</b>
F149	Historical PV Reverse Connection Warning (String 33~48)	Possible causes: PV reverse connection causing the trip-switch to open.	Contact the dealer or after-sales service center. Maintenance personnel need to check if the corresponding string has a reverse connection according to the historical PV reverse connection warning subcode, and check if there is a voltage difference in the PV panel configuration. After checking and confirming no fault, you can clear this warning via the APP interface by clearing historical faults.
F150	Battery 1 Low Voltage	Battery voltage is below the set value	-
F151	Battery 2 Low Voltage	Battery voltage is below the set value	-
F152	Low Voltage of Battery Power	Battery in non-charging mode, voltage below shutdown voltage	-
F153	Battery 1 High Voltage	-	-
F154	Battery 2 High Voltage	-	-

<b>Fault Code</b>	<b>Fault Name</b>	<b>Possible Cause</b>	<b>Troubleshooting Recommendations</b>
F155	Online Low Insulation Resistance	<p>1. Photovoltaic string shorted to protective earth.</p> <p>2. Photovoltaic string installed in a long-term humid environment with poor line-to-ground insulation.</p>	<p>1. Check the impedance between the photovoltaic string and protective earth. If a short circuit is found, rectify the short point.</p> <p>2. Check if the inverter's protective earth wire is correctly connected.</p> <p>3. If it is confirmed that the impedance is indeed below the default value in rainy/cloudy conditions, reset the "Insulation Resistance Protection Point".</p>
F156	Micro-grid Overload Warning	backup port input current too high	Occasional occurrence requires no action; if this alarm occurs frequently, please contact the dealer or after-sales service center.
F157	Manual Reset	-	-
F158	Generator Phase Sequence Abnormal	-	-
F159	Multiplexed Port Configuration Abnormal	Multiplexed (Generator) port configured as micro-grid or large load, but a generator is actually connected	Use the APP to change the configuration of the multiplexed (generator) port.
F160	EMS Forced Off-grid	EMS issued forced off-grid command, but off-grid function is not enabled	Enable the off-grid function.

<b>Fault Code</b>	<b>Fault Name</b>	<b>Possible Cause</b>	<b>Troubleshooting Recommendations</b>
F161	Passive Anti-islanding Protection	-	-
F162	Grid Type Fault	Actual grid type (two-phase or split-phase) does not match the set safety standard	Switch to the corresponding safety standard according to the actual grid type.
F163	Grid Phase Instability	Grid abnormal: Grid voltage phase change rate does not comply with local grid standards.	<p>1. If it occurs occasionally, it may be due to temporary grid abnormality. The inverter will resume normal operation after detecting a normal grid, requiring no manual intervention.</p> <p>2. If it occurs frequently, check if the grid frequency is within the allowable range. If not, please contact the local power operator.</p>

#### 9.5.2.2.5 Fault Symptom Handling

Fault Name	Fault Cause	Fault Handling Suggestions
Generator Failure	<ol style="list-style-type: none"> <li>1. If the generator is not connected, this fault will be displayed continuously.</li> <li>2. When the generator is operating, if it does not meet the generator safety regulations, this fault will be triggered.</li> </ol>	<ol style="list-style-type: none"> <li>1. If the generator is not connected, ignore this fault;</li> <li>2. When this fault occurs due to generator failure, it is normal. After the generator recovers, wait for a period of time, and the fault will be automatically cleared;</li> <li>3. This fault does not affect the normal operation of off-grid mode</li> <li>4. When both the generator and grid are connected and meet safety requirements, the grid has priority for grid connection, and it will operate in grid-connected state.</li> </ol>
BMS Status Bit Error	BMS module failure	Disconnect the AC output side switch and DC input side switch, after 5 minutes, close the AC output side switch and DC input side switch. If the fault still exists, please contact the dealer or after-sales service center.
Ambient Overtemperature	<ol style="list-style-type: none"> <li>1. Poor ventilation of the machine</li> <li>2. Hot air flow back to the ambient temperature sampling point</li> </ol>	Disconnect the AC output side switch and DC input side switch, after 5 minutes, close the AC output side switch and DC input side switch. If the fault still exists, please contact the dealer or after-sales service center.

Fault Name	Fault Cause	Fault Handling Suggestions
PV Terminal Overtemperature	PV terminal overtemperature, possible causes: 1. Inverter installation location is not ventilated. 2. Ambient temperature is too high. 3. Internal fan operation is abnormal.	1. Check whether the ventilation at the inverter installation location is good and whether the ambient temperature exceeds the maximum allowable ambient temperature range. 2. If it is not ventilated or the ambient temperature is too high, please improve its ventilation and heat dissipation conditions. 3. If both ventilation and ambient temperature are normal, please contact the dealer or after-sales service center.
BAT Terminal Overtemperature	BAT terminal overtemperature, possible causes: 1. Inverter installation location is not ventilated. 2. Ambient temperature is too high.	1. Check whether the ventilation at the inverter installation location is good and whether the ambient temperature exceeds the maximum allowable ambient temperature range.
AC Terminal Overtemperature Warning	AC terminal overtemperature, possible causes: 1. Inverter installation location is not ventilated. 2. Ambient temperature is too high. 3. Internal fan operation is abnormal.	2. If it is not ventilated or the ambient temperature is too high, please improve its ventilation and heat dissipation conditions. 3. If both ventilation and ambient temperature are normal, please contact the dealer or after-sales service center.

<b>Fault Name</b>	<b>Fault Cause</b>	<b>Fault Handling Suggestions</b>
BAT Terminal Overtemperature Warning	BAT terminal overtemperature, possible causes: 1. Inverter installation location is not ventilated. 2. Ambient temperature is too high.	1. Check whether the ventilation at the inverter installation location is good and whether the ambient temperature exceeds the maximum allowable ambient temperature range. 2. If it is not ventilated or the ambient temperature is too high, please improve its ventilation and heat dissipation conditions. 3. If both ventilation and ambient temperature are normal, please contact the dealer or after-sales service center.
Three-phase on-grid fault	Three-phase external wiring error	Rewire.
External STS Failure	Abnormal connection cable between inverter and STS	Check whether the wiring sequence of the harness connection between the inverter and STS corresponds one by one in order.

<b>Fault Name</b>	<b>Fault Cause</b>	<b>Troubleshooting Suggestion</b>
Parallel Comm Timeout Shutdown	In parallel operation, if a slave unit has not communicated with the master unit for over 400 seconds.	Check if the parallel communication harness is securely connected. Check for duplicate slave addresses.
Three-phase off-grid phase loss fault	Phase loss in a three-phase system.	1. Check if all inverters are powered on. 2. Check if each phase of the three-phase system is connected to an inverter.

Fault Name	Fault Cause	Troubleshooting Suggestion
EPO	External hardware EPO button triggered or remote EPO command triggered.	<ol style="list-style-type: none"> <li>1. If triggered intentionally via remote shutdown, it can be ignored.</li> <li>2. If not triggered intentionally, please contact the dealer or after-sales service center.</li> </ol>
High Combustible Gas Concentration	Automatically triggered when the combustible gas device detects a concentration of 20% LEL or higher.	<ol style="list-style-type: none"> <li>1. After the fault occurs, the unit will automatically open the air damper to exhaust and reduce the concentration. The fault will clear automatically after the concentration remains below 5% LEL for 15 minutes.</li> <li>2. If the fault triggers a cluster-level fire protection fault, the air damper will automatically close. Confirm the damper status within 30s to ensure the cluster-level fire protection operates in a sealed space.</li> <li>3. Please contact the dealer or after-sales service center.</li> </ol>
Combustible Gas Device Air Damper Control/Feedback Signal Mismatch	Mismatch between the control signal to open the air damper and the feedback signal.	<ol style="list-style-type: none"> <li>1. Check the harness signal connections for issues.</li> <li>2. Please contact the dealer or after-sales service center.</li> </ol>
One-Touch Shutdown	Check via the App if the one-touch shutdown function is enabled.	Disable the one-touch shutdown.

Fault Name	Fault Cause	Troubleshooting Suggestion
Offline Shutdown	-	-
Remote Shutdown	-	-
On-Grid SPD Fault	-	<ol style="list-style-type: none"> <li>1. Try restarting the unit and observe if the fault clears.</li> <li>2. If the fault persists after restarting, please contact the dealer or after-sales service center.</li> </ol>
Off-Grid SPD Fault	-	<ol style="list-style-type: none"> <li>1. Try restarting the unit and observe if the fault clears.</li> <li>2. If the fault persists after restarting, please contact the dealer or after-sales service center.</li> </ol>
Child Node Communication Failure	Internal communication abnormality.	<ol style="list-style-type: none"> <li>1. Try restarting the unit and observe if the fault clears.</li> <li>2. If the fault persists after restarting, please contact the dealer or after-sales service center.</li> </ol>
Dehumidifier Communication Fault	Abnormal communication link between the dehumidifier and the LC control box.	<ol style="list-style-type: none"> <li>1. Check the communication harness link and observe if the fault clears.</li> <li>2. Try restarting the unit and observe if the fault clears.</li> <li>3. If the fault persists after restarting, please contact the dealer or after-sales service center.</li> </ol>

Fault Name	Fault Cause	Troubleshooting Suggestion
Combustible Gas Detection Device Communication Fault	<ol style="list-style-type: none"> <li>1. The combustible gas device was not properly configured with the 485 address set to 2 during factory settings.</li> <li>2. Abnormal communication link between the combustible gas device and the LC control box.</li> </ol>	<ol style="list-style-type: none"> <li>1. Check the communication harness link and observe if the fault clears.</li> <li>2. Try restarting the unit and observe if the fault clears.</li> <li>3. Use the method provided by the combustible gas device manufacturer to check if the device address is 2. If not, modify it.</li> <li>4. If the fault persists after restarting, please contact the dealer or after-sales service center.</li> </ol>
DG Communication Failure	Abnormal communication link between the control board and the diesel generator.	<ol style="list-style-type: none"> <li>1. Check the communication harness link and observe if the fault clears.</li> <li>2. Try restarting the unit and observe if the fault clears.</li> <li>3. If the fault persists after restarting, please contact the dealer or after-sales service center.</li> </ol>
Battery Over Voltage	<ol style="list-style-type: none"> <li>1. Single cell voltage too high.</li> <li>2. Voltage sampling line abnormal.</li> </ol>	Record the fault phenomenon, restart the battery, wait a few minutes, and confirm if the fault disappears. If the problem persists after restarting, please contact the after-sales service center.
Battery Undervoltage	<ol style="list-style-type: none"> <li>1. Total battery voltage too high.</li> <li>2. Voltage sampling line abnormal.</li> </ol>	

Fault Name	Fault Cause	Troubleshooting Suggestion
	1. Total battery voltage too low. 2. Voltage sampling line abnormal.	
Battery Overcurrent	1. Charging current too high, battery current limiting abnormal: sudden changes in temperature and voltage values. 2. Inverter response abnormal.	
	Battery discharge current too high.	
Battery Overtemperature	1. Ambient temperature too high. 2. Temperature sensor abnormal.	
Battery Undertemperature	1. Ambient temperature too low. 2. Temperature sensor abnormal.	
Battery Terminal Overtemperature	Terminal temperature too high.	

Fault Name	Fault Cause	Troubleshooting Suggestion
Battery Imbalance	<ol style="list-style-type: none"> <li>1. Excessive temperature difference. At different stages, the battery will limit its power, i.e., limit charge/discharge current. Therefore, this issue is generally difficult to occur.</li> <li>2. Cell capacity degradation, leading to excessive internal resistance and large temperature rise during overcurrent, causing significant temperature difference.</li> <li>3. Poor welding of cell tabs, causing the cell to heat up too quickly during overcurrent.</li> <li>4. Temperature sampling issue.</li> <li>5. Power line connection loose.</li> </ol>	

Fault Name	Fault Cause	Troubleshooting Suggestion
	1. Inconsistent cell aging levels. 2. Slave board chip issues can also cause excessive cell voltage difference. 3. Slave board balancing issues can also cause excessive cell voltage difference. 4. Harness issues.	
Insulation Resistance	Insulation resistance damaged.	Check if the ground wire is properly connected, restart the battery. If the problem persists after restarting, please contact the after-sales service center.
Pre-charging Failure	Pre-charging failed.	Indicates that during pre-charging, the voltage across the pre-charge MOS always exceeds the specified threshold. After powering off and restarting, observe if the fault persists. Check if the wiring is correct and if the pre-charge MOS is damaged.
Sampling Line Fault	Battery sampling line poor contact or disconnected.	Check wiring, restart the battery. If the problem persists after restarting, please contact the after-sales service center.
	Cell voltage sampling line poor contact or disconnected.	Check wiring, restart the battery. If the problem persists after restarting, please contact the after-sales service center.
	Cell temperature sampling line poor contact or disconnected.	

Fault Name	Fault Cause	Troubleshooting Suggestion
	Dual-channel current comparison error too large, or current sampling line loop abnormal.	
	Dual-channel voltage comparison error too large, or MCU and AFE voltage comparison error too large, or voltage sampling line loop abnormal.	
	Temperature sampling line loop abnormal, poor contact, or disconnected.	
	Overvoltage level 5 or overtemperature level 5, tripped three-terminal fuse.	
Relay or MOS Overtemperature	Relay or MOS overtemperature.	This fault indicates the MOS tube temperature exceeds the specified threshold. Power off and let it stand for 2 hours for temperature recovery.
Shunt Overtemperature	Shunt overtemperature.	This fault indicates the shunt temperature exceeds the specified threshold. Power off and let it stand for 2 hours for temperature recovery.

Fault Name	Fault Cause	Troubleshooting Suggestion
BMS1 Other Fault 1 (Residential Storage)	Relay or MOS open circuit.	<ol style="list-style-type: none"> <li>1. Upgrade software, power off and let stand for 5 minutes, restart and see if the fault persists.</li> <li>2. If it persists, replace the battery pack.</li> </ol>
	Relay or MOS short circuit.	<ol style="list-style-type: none"> <li>1. Upgrade software, power off and let stand for 5 minutes, restart and see if the fault persists.</li> <li>2. If it persists, replace the battery pack.</li> </ol>
	Communication abnormal between master cluster and slave clusters, or cell inconsistency between clusters.	<ol style="list-style-type: none"> <li>1. Check the slave battery information, software version, and whether the communication cable connection to the master is normal.</li> <li>2. Upgrade software.</li> </ol>
	Battery system loop harness abnormal, causing the interlock signal not to form a loop.	Check if the terminal resistor is installed correctly.
	BMS and PCS communication abnormal.	<ol style="list-style-type: none"> <li>1. Confirm the communication cable interface definition between the inverter and the connected battery is correct.</li> <li>2. Please contact the after-sales service center to check backend data and observe if the inverter and battery software match correctly.</li> </ol>
	BMS master and slave controller communication harness abnormal.	<ol style="list-style-type: none"> <li>1. Check wiring, restart the battery.</li> <li>2. Upgrade battery software. If the problem persists after restarting, please contact the after-sales service center.</li> </ol>

Fault Name	Fault Cause	Troubleshooting Suggestion
	Communication loss between main negative chips.	
	Circuit breaker, shunt trip abnormal.	<ol style="list-style-type: none"> <li>1. Power off and let stand for 5 minutes, restart and see if the fault persists.</li> <li>2. Observe the blind plugs at the bottom of the PACK and PCU, check if the communication pins are loose or misaligned.</li> </ol>
	MCU self-test failure.	Upgrade software, restart the battery. If the problem persists after restarting, please contact the after-sales service center.
	<ol style="list-style-type: none"> <li>1. Software version too low or BMS board damaged.</li> <li>2. Large number of parallel inverters, excessive inrush current during battery pre-charging.</li> </ol>	<ol style="list-style-type: none"> <li>1. Upgrade software, observe if the fault persists.</li> <li>2. For parallel systems, perform a black start of the battery first, then start the inverters.</li> </ol>
	MCU internal fault.	Upgrade software, restart the battery. This usually indicates MCU or external component damage. If the problem persists after restarting, please contact the after-sales service center.
	Total control current exceeds the specified threshold.	<ol style="list-style-type: none"> <li>1. Power off and let stand for 5 minutes, restart and see if the fault persists.</li> <li>2. Check if the inverter power setting is too high, causing it to exceed the bus load.</li> </ol>

Fault Name	Fault Cause	Troubleshooting Suggestion
	Inconsistent cells in parallel clusters.	Confirm if the cells in the parallel clusters are consistent.
	Reverse polarity connection of parallel cluster battery positive/negative terminals.	Check if the positive/negative terminals of the parallel cluster batteries are reversed.
	Severe overtemperature, overvoltage, etc., triggering the fire protection system.	Contact the after-sales service center.
Air Conditioner Failure	Air conditioner abnormal failure.	Try restarting the system. If the fault is not resolved, please contact the after-sales service center.
	Cabinet door not closed.	Check if the cabinet door is properly closed.
	Supply voltage too high.	Confirm the supply voltage meets the air conditioner input voltage requirements. Confirm compliance before reapplying power.
	Insufficient supply voltage.	
	No voltage input.	
	Unstable supply voltage.	
	Compressor voltage unstable.	Try restarting the system. If the fault is not resolved, please contact the after-sales service center.
	Sensor poor contact or damaged.	

Fault Name	Fault Cause	Troubleshooting Suggestion
	Air conditioner fan abnormal.	
BMS1 Other Fault 2 (Residential Storage)	DCDC internal voltage or current abnormal.	Refer to specific DC fault content.
	DCDC overload or heatsink temperature too high, etc.	
	Cell sampling abnormal or inconsistent aging levels.	Please contact the after-sales service center.
	Fan operation not executed normally.	Please contact the after-sales service center.
	Output terminal screw loose or poor contact.	<ol style="list-style-type: none"> <li>1. Power off the battery, check wiring and output terminal screw condition.</li> <li>2. After confirmation, restart the battery, observe if the fault persists. If it persists, please contact the after-sales service center.</li> </ol>
	Battery used for too long or cells severely damaged.	Please contact the after-sales service center to replace the pack.
	<ol style="list-style-type: none"> <li>1. Software version too low or BMS board damaged.</li> <li>2. Large number of parallel inverters, excessive inrush current during battery pre-charging.</li> </ol>	<ol style="list-style-type: none"> <li>1. Upgrade software, observe if the fault persists.</li> <li>2. For parallel systems, perform a black start of the battery first, then start the inverters.</li> </ol>

Fault Name	Fault Cause	Troubleshooting Suggestion
	Heating film damaged.	Please contact the after-sales service center.
	Heating film three-terminal fuse blown, heating function unavailable.	Please contact the after-sales service center.
	Software model, Cell Type, hardware model mismatch.	Check if the software model, SN, Cell Type, and hardware model are consistent. If not, please contact the after-sales service center.
	Thermal management board communication wire break.	<ol style="list-style-type: none"> <li>1. Power off and let stand for 5 minutes, restart and see if the fault persists.</li> <li>2. If the fault does not recover, contact after-sales to replace the pack.</li> </ol>
	Pack fan fault signal triggered.	
DCDC Fault	Output terminal voltage too high.	Check the output terminal voltage. If the output voltage is normal and the fault does not clear after restarting the battery, please contact the after-sales service center.
	DCDC module detects battery voltage exceeds maximum charging voltage.	Stop charging, discharge to SOC below 90% or let stand for 2 hours. If ineffective and the fault persists after restart, please contact the after-sales service center.
	Heatsink temperature too high.	Let the battery stand for 1 hour for heatsink temperature to drop. If ineffective and the fault persists after restart, please contact the after-sales service center.

Fault Name	Fault Cause	Troubleshooting Suggestion
	Battery discharge current too high.	Check if the load exceeds the battery's discharge capability. Turn off the load or stop PCS operation for 60s. If ineffective and the fault persists after restart, please contact the after-sales service center.
	Output terminal power harness positive/negative terminals reversed with parallel cluster battery or PCS.	Turn off the battery manual switch, check if the output terminal wiring is correct, restart the battery.
	Output power relay cannot close.	Check if the output terminal wiring is correct and if there is a short circuit. If ineffective and the fault persists after restart, please contact the after-sales service center.
	Power device temperature too high.	Let the battery stand for 1 hour for internal power device temperature to drop. If ineffective and the fault persists after restart, please contact the after-sales service center.
	Relay welded/stuck.	If the fault persists after restart, please contact the after-sales service center.
Battery Rack Circulating Current Failure	1. Cell imbalance. 2. First power-on without full charge calibration.	Record the fault phenomenon, restart the battery, wait a few minutes, and confirm if the fault disappears. If the problem persists after restarting, please contact the after-sales service center.
BMS1 Other Fault 3 (Large-scale Storage)	Communication abnormal with Linux module.	1. Check if the communication cable connection is normal. 2. Upgrade software, restart the battery and observe if the fault persists. If it persists, please contact the after-sales service center.

<b>Fault Name</b>	<b>Fault Cause</b>	<b>Troubleshooting Suggestion</b>
	Cell temperature rise too fast.	Cell abnormal, contact after-sales to replace the pack.
	SOC below 10%.	Charge the battery.
	SN writing does not comply with rules.	Check if the SN digit count is normal. If abnormal, please contact the after-sales service center.
	1. Communication abnormal within battery cluster daisy chain. 2. Inconsistent cell aging levels between battery clusters.	1. Check the pack contact condition within a single cluster. 2. Confirm the usage status of each cluster, such as cumulative charge/discharge capacity, cycle count, etc. 3. Please contact the after-sales service center.
	Pack internal humidity too high.	-
	Fuse blown.	Contact after-sales to replace the pack.
	Battery level low.	Charge the battery.
BMS1 Other Fault 4 (Large-scale Storage)	Circuit breaker abnormal.	Contact after-sales to replace the pack.
	External device abnormal.	Contact after-sales to replace the pack.
Contactator Failure 1	-	-
Contactator Failure 2	-	-
Overload Protection (Ksic)	Sustained overload (exceeding 690kVA) for 10s.	Please contact the after-sales service center.

Fault Name	Fault Cause	Troubleshooting Suggestion
Overload Protection (Smart Port)	Sustained overload (exceeding 690kVA) for 10s.	Please contact the after-sales service center.
Overcurrent Protection (Ksic)	-	-
Overcurrent Protection (Smart Port)	-	-
Master AC On Meter Comm Error	1. Meter may not be connected to the master. 2. Meter communication cable may be loose.	1. Check if the meter is connected to the master. 2. Check if the meter communication cable is loose.
Parallel Slave Meter Error	Meter connected to a slave unit.	Set the unit with the meter connected as the master.
Slave AC On Timeout with Master	1. Slave address setting error. 2. Slave communication cable loose.	1. Check for duplicate slave addresses. 2. Check if the parallel communication cable is loose.

### 9.5.2.3 Battery Fault

- **Lynx C Series 60kWh Commercial and Industrial Battery System**

No.	Fault Name	Possible Cause	Troubleshooting
1	Battery Over Voltage	Charging continues when the battery is fully charged	Stop charging. If it does not recover automatically, please contact professional technical personnel to restart the system.

No.	Fault Name	Possible Cause	Troubleshooting
2	Battery Undervoltage	Discharging continues when the battery is fully discharged	Stop discharging. If it does not recover automatically, please contact professional technical personnel to restart the system.
3	Battery Overcurrent	Current exceeds the system maximum during charging or discharging	Reduce power. If it does not recover automatically, please contact professional technical personnel to restart the system.
4	Battery Overtemperature	Temperature is too high during charging or discharging	Perform cooling. If it does not recover automatically, please contact professional technical personnel to restart the system.
5	Battery Undertemperature	Temperature is too low during charging or discharging	Perform heating. If it does not recover automatically, please contact professional technical personnel to restart the system.
6	Battery Terminal Overtemperature	Temperature is too high during charging or discharging	Perform cooling. If it does not recover automatically, please contact professional technical personnel to restart the system.
7	Battery Imbalance	Excessive temperature or voltage difference between individual cells	Stop charging/discharging and wait for temperature recovery. Perform balancing if voltage difference is excessive.
8	Insulation Resistance	System insulation resistance is low	Check grounding condition
9	Precharge Failure	Precharge circuit component failure	Check precharge circuit components
10	Harness Fault	Abnormal voltage, temperature, or current sensing harness	Check the corresponding harness
11	Relay Open Circuit	Relay Failure	Replace the relay
12	Relay Short Circuit	Relay Failure	Replace the relay

No.	Fault Name	Possible Cause	Troubleshooting
13	Parallel Cluster Fault	Slave cluster communication loss	Check the reliability of the master-slave harness connection
14	PCS Comm Loss	Abnormal communication harness with PCS	Check the reliability of the harness connection
15	BMU Communication Fault	Abnormal communication harness between BCU and BMU	Check the reliability of the harness connection
16	Breaker Sticking Fault	Molded case circuit breaker failure	Replace the molded case circuit breaker
17	Fire Suppression System Triggered	Internal thermal runaway in the system	Please contact the after-sales service center.
18	Air Conditioner Failure	Abnormal fault in the air conditioning system	Please contact the after-sales service center.

• **BAT-S Series 25.6-56.3kWh High-Voltage Battery**

No.	Fault Name	Possible Causes	Troubleshooting
1	Charging Overvoltage <sup>2</sup>	<ul style="list-style-type: none"> <li>Cell voltage/total voltage is too high</li> <li>Voltage sampling line abnormality</li> </ul>	<ol style="list-style-type: none"> <li>Power off and let it sit for 5 minutes. After restarting, check if the fault persists.</li> <li>If the fault is not resolved, contact GoodWe after-sales service.</li> </ol>

No.	Fault Name	Possible Causes	Troubleshooting
2	Charging Overvoltage <sup>3</sup>	<ul style="list-style-type: none"> <li>• Cell voltage/total voltage is too high</li> <li>• Voltage sampling line abnormality</li> </ul>	<ol style="list-style-type: none"> <li>1. Power off and let it sit for 5 minutes. After restarting, check if the fault persists.</li> <li>2. If the fault is not resolved, contact GoodWe after-sales service.</li> </ol>
3	Discharge Undervoltage <sup>3</sup>	<ul style="list-style-type: none"> <li>• Cell voltage/total voltage is too low</li> <li>• Voltage sampling line abnormality</li> </ul>	<ol style="list-style-type: none"> <li>1. Power off and let it sit for 5 minutes. After restarting, check if the fault persists.</li> <li>2. Determine the inverter's working condition. Check if the battery is not being charged due to issues like operating mode. Try charging the battery via the inverter and observe if the fault is resolved.</li> <li>3. If the fault is not resolved, contact GoodWe after-sales service.</li> </ol>

No.	Fault Name	Possible Causes	Troubleshooting
4	Discharge Undervoltage2	<ul style="list-style-type: none"> <li>• Cell voltage/total voltage is too low</li> <li>• Voltage sampling line abnormality</li> </ul>	<ol style="list-style-type: none"> <li>1. Power off and let it sit for 5 minutes. After restarting, check if the fault persists.</li> <li>2. Determine the inverter's working condition. Check if the battery is not being charged due to issues like operating mode. Try charging the battery via the inverter and observe if the fault is resolved.</li> <li>3. If the fault is not resolved, contact GoodWe after-sales service.</li> </ol>
5	Cell Overvoltage2	<ul style="list-style-type: none"> <li>• Cell voltage/total voltage is too high</li> <li>• Voltage sampling line abnormality</li> </ul>	<ol style="list-style-type: none"> <li>1. Power off and let it sit for 5 minutes. After restarting, check if the fault persists.</li> </ol> <p>If the fault is not resolved, contact GoodWe after-sales service.</p>
6	Cell Undervoltage2	Cell undervoltage	<ol style="list-style-type: none"> <li>1. Power off and let it sit for 5 minutes. After restarting, check if the fault persists.</li> <li>2. Determine the inverter's working condition. Check if the battery is not being charged due to issues like operating mode. Try charging the battery via the inverter and observe if the fault is resolved.</li> <li>3. If the fault is not resolved, contact GoodWe after-sales service.</li> </ol>

No.	Fault Name	Possible Causes	Troubleshooting
7	Significant Cell Voltage Variation <sup>2</sup>	Significant cell voltage variation	<ol style="list-style-type: none"> <li>1. Restart the battery and wait for 12 hours.</li> <li>2. If the fault is not resolved, contact GoodWe after-sales service.</li> </ol>
8	Charging Overcurrent <sup>2</sup>	<ul style="list-style-type: none"> <li>• Charging current is too high, battery current limiting abnormality: Sudden changes in temperature and voltage values</li> <li>• Inverter response abnormality</li> </ul>	<ol style="list-style-type: none"> <li>1. Power off and let it sit for 5 minutes. After restarting, check if the fault persists.</li> <li>2. Check if the inverter power setting is too high, causing it to exceed the battery's rated operating current.</li> <li>3. If the fault is not resolved, contact GoodWe after-sales service.</li> </ol>
9	Discharge Overcurrent <sup>2</sup>	<ul style="list-style-type: none"> <li>• Discharge current is too high, battery current limiting abnormality: Sudden changes in temperature and SOC values</li> <li>• Inverter response abnormality</li> </ul>	
10	Battery Cell High Temperature <sup>2</sup>	<ul style="list-style-type: none"> <li>• Cell temperature is too high</li> <li>• Temperature sensor abnormality</li> </ul>	<ol style="list-style-type: none"> <li>1. Power off and let it sit for 30 minutes. After restarting, check if the fault persists.</li> <li>2. If the fault is not resolved, contact GoodWe after-sales service.</li> </ol>

No.	Fault Name	Possible Causes	Troubleshooting
11	Battery Cell Low Temperature2	<ul style="list-style-type: none"> <li>• Ambient temperature is too low</li> <li>• Temperature sensor abnormality</li> </ul>	<ol style="list-style-type: none"> <li>1. Power off and let it sit for 30 minutes. After restarting, check if the fault persists.</li> <li>2. If the fault is not resolved, contact GoodWe after-sales service.</li> </ol>
12	Charging Overtemperature2	<ul style="list-style-type: none"> <li>• Cell temperature is too high</li> <li>• Temperature sensor abnormality</li> </ul>	<ol style="list-style-type: none"> <li>1. Power off and let it sit for 30 minutes. After restarting, check if the fault persists.</li> <li>2. If the fault is not resolved, contact GoodWe after-sales service.</li> </ol>
13	Charging Low Temperature2	<ul style="list-style-type: none"> <li>• Ambient temperature is too low</li> <li>• Temperature sensor abnormality</li> </ul>	<ol style="list-style-type: none"> <li>1. Power off and let it sit for 30 minutes. After restarting, check if the fault persists.</li> <li>2. If the fault is not resolved, contact GoodWe after-sales service.</li> </ol>
14	Discharge Overtemperature2	<ul style="list-style-type: none"> <li>• Cell temperature is too high</li> <li>• Temperature sensor abnormality</li> </ul>	<ol style="list-style-type: none"> <li>1. Power off and let it sit for 30 minutes. After restarting, check if the fault persists.</li> <li>2. If the fault is not resolved, contact GoodWe after-sales service.</li> </ol>

No.	Fault Name	Possible Causes	Troubleshooting
15	Discharge Low Temperature2	<ul style="list-style-type: none"> <li>• Ambient temperature is too low</li> <li>• Temperature sensor abnormality</li> </ul>	<ol style="list-style-type: none"> <li>1. Power off and let it sit for 30 minutes. After restarting, check if the fault persists.</li> <li>2. If the fault is not resolved, contact GoodWe after-sales service.</li> </ol>
16	Significant Cell Temperature Variation2	Significant cell temperature variation	<ol style="list-style-type: none"> <li>1. Power off and let it sit for 30 minutes. After restarting, check if the fault persists.</li> <li>2. If the fault is not resolved, contact GoodWe after-sales service.</li> </ol>
17	Precharge Disabled	Precharge MOS closure failure	<ol style="list-style-type: none"> <li>1. Power off and let it sit for 5 minutes. After restarting, check if the fault persists.</li> <li>2. If the fault is not resolved, contact GoodWe after-sales service.</li> </ol>
18	Battery Tripping	Battery Trip	<ol style="list-style-type: none"> <li>1. Let it sit for 10 minutes, then re-close to restore.</li> <li>2. If the fault is not resolved, contact GoodWe after-sales service.</li> </ol>

No.	Fault Name	Possible Causes	Troubleshooting
19	Battery and Inverter Comm Failure	Battery and Inverter Comm Failure	<ol style="list-style-type: none"> <li>1. Confirm the wiring sequence of the communication cable and DC cable is correct, and that the connection is normal.</li> <li>2. Restart the inverter and battery.</li> <li>3. If the fault is not resolved, contact GoodWe after-sales service.</li> </ol>
20	Specific Failures	Battery specific failure	Please contact the after-sales service center.
21	Parallel Cluster Fault	Slave cluster lost connection Parallel cluster failure	Check the reliability of the master-slave harness communication connection. Please contact the after-sales service center.
22	Application Software Fault	Software self-test failure	Please contact the after-sales service center.
23	Microelectronics Fault	Electronic component failure	Please contact the after-sales service center.
24	Main Controller Overload	Exceeds power line carrying capacity range	Stop charging. If it does not recover automatically, please contact professional technical personnel to restart the system.
25	SN Abnormality	Batteries with identical SN exist	Please contact the after-sales service center.
26	Circuit Breaker Abnormality	Molded case circuit breaker abnormal trip	Replace the molded case circuit breaker.

• **BAT-C Series 61.4-112.6kWh Commercial and Industrial Battery System**

No.	Fault Name	Possible Cause	Troubleshooting
1	Charging Overvoltage <sup>2</sup>	<ul style="list-style-type: none"> <li>• Cell voltage/Total voltage too high</li> <li>• Voltage sampling line abnormal</li> </ul>	<ol style="list-style-type: none"> <li>1. Power off and let it rest for 5 minutes. After restarting, check if the fault persists.</li> <li>2. If the fault is not resolved, contact GoodWe after-sales service.</li> </ol>
2	Charging Overvoltage <sup>3</sup>	<ul style="list-style-type: none"> <li>• Cell voltage/Total voltage too high</li> <li>• Voltage sampling line abnormal</li> </ul>	<ol style="list-style-type: none"> <li>1. Power off and let it rest for 5 minutes. After restarting, check if the fault persists.</li> <li>2. If the fault is not resolved, contact GoodWe after-sales service.</li> </ol>
3	Discharge Undervoltage <sup>3</sup>	<ul style="list-style-type: none"> <li>• Cell voltage/Total voltage too low</li> <li>• Voltage sampling line abnormal</li> </ul>	<ol style="list-style-type: none"> <li>1. Power off and let it rest for 5 minutes. After restarting, check if the fault persists.</li> <li>2. Confirm the inverter's working status. Check if the inverter is not charging the battery due to working mode or other issues. Try charging the battery via the inverter and observe if the fault is resolved.</li> <li>3. If the fault is not resolved, contact GoodWe after-sales service.</li> </ol>

No.	Fault Name	Possible Cause	Troubleshooting
4	Discharge Undervoltage2	<ul style="list-style-type: none"> <li>• Cell voltage/Total voltage too low</li> <li>• Voltage sampling line abnormal</li> </ul>	<ol style="list-style-type: none"> <li>1. Power off and let it rest for 5 minutes. After restarting, check if the fault persists.</li> <li>2. Confirm the inverter's working status. Check if the inverter is not charging the battery due to working mode or other issues. Try charging the battery via the inverter and observe if the fault is resolved.</li> <li>3. If the fault is not resolved, contact GoodWe after-sales service.</li> </ol>
5	Cell Overvoltage2	<ul style="list-style-type: none"> <li>• Cell voltage/Total voltage too high</li> <li>• Voltage sampling line abnormal</li> </ul>	<ol style="list-style-type: none"> <li>1. Power off and let it rest for 5 minutes. After restarting, check if the fault persists.</li> </ol> <p>If the fault is not resolved, contact GoodWe after-sales service.</p>
6	Cell Undervoltage2	Cell undervoltage	<ol style="list-style-type: none"> <li>1. Power off and let it rest for 5 minutes. After restarting, check if the fault persists.</li> <li>2. Confirm the inverter's working status. Check if the inverter is not charging the battery due to working mode or other issues. Try charging the battery via the inverter and observe if the fault is resolved.</li> <li>3. If the fault is not resolved, contact GoodWe after-sales service.</li> </ol>

No.	Fault Name	Possible Cause	Troubleshooting
7	Significant Cell Voltage Variation <sup>2</sup>	Significant cell voltage variation	<ol style="list-style-type: none"> <li>1. Restart the battery and wait for 12 hours.</li> <li>2. If the fault is not resolved, contact GoodWe after-sales service.</li> </ol>
8	Charging Overcurrent <sup>2</sup>	<ul style="list-style-type: none"> <li>• Charging current too high, battery current limiting abnormal: Sudden change in temperature and voltage values</li> <li>• Inverter response abnormal</li> </ul>	<ol style="list-style-type: none"> <li>1. Power off and let it rest for 5 minutes. After restarting, check if the fault persists.</li> <li>2. Check if the inverter power setting is too high, causing it to exceed the battery's rated operating current.</li> <li>3. If the fault is not resolved, contact GoodWe after-sales service.</li> </ol>
9	Discharge Overcurrent <sup>2</sup>	<ul style="list-style-type: none"> <li>• Discharge current too high, battery current limiting abnormal: Sudden change in temperature and SOC values</li> <li>• Inverter response abnormal</li> </ul>	
10	Battery Cell High Temperature <sup>2</sup>	<ul style="list-style-type: none"> <li>• Cell temperature too high</li> <li>• Temperature sensor abnormal</li> </ul>	<ol style="list-style-type: none"> <li>1. Power off and let it rest for 30 minutes. After restarting, check if the fault persists.</li> <li>2. If the fault is not resolved, contact GoodWe after-sales service.</li> </ol>

No.	Fault Name	Possible Cause	Troubleshooting
11	Battery Cell Low Temperature2	<ul style="list-style-type: none"> <li>• Ambient temperature too low</li> <li>• Temperature sensor abnormal</li> </ul>	<ol style="list-style-type: none"> <li>1. Power off and let it rest for 30 minutes. After restarting, check if the fault persists.</li> <li>2. If the fault is not resolved, contact GoodWe after-sales service.</li> </ol>
12	Charging Overtemperature2	<ul style="list-style-type: none"> <li>• Cell temperature too high</li> <li>• Temperature sensor abnormal</li> </ul>	<ol style="list-style-type: none"> <li>1. Power off and let it rest for 30 minutes. After restarting, check if the fault persists.</li> <li>2. If the fault is not resolved, contact GoodWe after-sales service.</li> </ol>
13	Charging Low Temperature2	<ul style="list-style-type: none"> <li>• Ambient temperature too low</li> <li>• Temperature sensor abnormal</li> </ul>	<ol style="list-style-type: none"> <li>1. Power off and let it rest for 30 minutes. After restarting, check if the fault persists.</li> <li>2. If the fault is not resolved, contact GoodWe after-sales service.</li> </ol>
14	Discharge Overtemperature2	<ul style="list-style-type: none"> <li>• Cell temperature too high</li> <li>• Temperature sensor abnormal</li> </ul>	<ol style="list-style-type: none"> <li>1. Power off and let it rest for 30 minutes. After restarting, check if the fault persists.</li> <li>2. If the fault is not resolved, contact GoodWe after-sales service.</li> </ol>

No.	Fault Name	Possible Cause	Troubleshooting
15	Discharge Low Temperature2	<ul style="list-style-type: none"> <li>• Ambient temperature too low</li> <li>• Temperature sensor abnormal</li> </ul>	<ol style="list-style-type: none"> <li>1. Power off and let it rest for 30 minutes. After restarting, check if the fault persists.</li> <li>2. If the fault is not resolved, contact GoodWe after-sales service.</li> </ol>
16	Significant Cell Temperature Variation2	Significant cell temperature variation	<ol style="list-style-type: none"> <li>1. Power off and let it rest for 30 minutes. After restarting, check if the fault persists.</li> <li>2. If the fault is not resolved, contact GoodWe after-sales service.</li> </ol>
17	Precharge Disabled	Precharge MOS closing failure	<ol style="list-style-type: none"> <li>1. Power off and let it rest for 5 minutes. After restarting, check if the fault persists.</li> <li>2. If the fault is not resolved, contact GoodWe after-sales service.</li> </ol>
18	Battery Tripping	Battery Trip	<ol style="list-style-type: none"> <li>1. Let it rest for 10 minutes, then re-close to recover.</li> <li>2. If the fault is not resolved, contact GoodWe after-sales service.</li> </ol>

No.	Fault Name	Possible Cause	Troubleshooting
19	Battery and Inverter Comm Failure	Battery and inverter communication failure	<ol style="list-style-type: none"> <li>1. Confirm the wiring sequence of the communication cable and DC cable is correct, and check for proper connectivity.</li> <li>2. Restart the inverter and battery.</li> <li>3. If the fault is not resolved, contact GoodWe after-sales service.</li> </ol>
20	Specific Failures	Battery specific failure	Please contact the after-sales service center.
21	Parallel Cluster Fault	Slave cluster lost connection Parallel cluster failure	Check the reliability of the master/slave harness communication connection Please contact the after-sales service center.
22	Application Software Fault	Software self-check failure	Please contact the after-sales service center
23	Microelectronics Fault	Electronic component failure	Please contact the after-sales service center
24	Main Controller Overload	Exceeds power cable carrying capacity range	Stop charging. If it does not recover automatically, please contact a professional technician to restart the system.
25	SN Abnormal	Batteries with identical SN exist	Please contact the after-sales service center
26	Circuit Breaker Abnormal	Molded case circuit breaker abnormal disconnection	Replace the molded case circuit breaker

No.	Fault Name	Possible Cause	Troubleshooting
27	Circuit Breaker Sticking Fault	Molded case circuit breaker fault or auxiliary circuit breaker fault	Replace the molded case circuit breaker or replace the auxiliary circuit breaker
28	Fire Protection System Triggered	Internal thermal runaway or false fire protection trigger	Please contact the after-sales service center
29	Air Conditioning Fault	Abnormal fault occurred in the air conditioning system	Please contact the after-sales service center
30	Door Access Fault	Door abnormally opened or door access sensor damaged	Close the door or replace the door access sensor
31	Emergency Stop Triggered	Emergency stop pressed or emergency stop button damaged	Replace the emergency stop button
32	PACK Fan Fault	PACK fan stalled or not working	Replace the corresponding PACK fan

### 9.5.3 Post-Fault Clearance Processing

In energy storage systems, after certain faults are handled, post-processing is required for the system to resume normal operation.

#### 9.5.3.1 Clearing AFCI Fault Alarms

【Software Used】 : SolarGo App

【Clearing Method】 :

1. Navigate via [Home] > [Settings] > [Advanced Settings] > [DC Arc Detection].
2. Click the [Clear AFCI Fault Alarms] button.

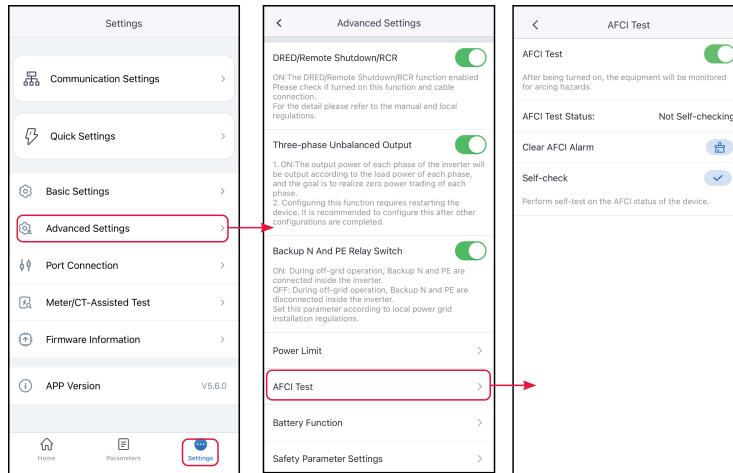

# 10 technical parameter

## 10.1 Smart Meter Technical Data

### 10.1.1 GM330

technical parameter		GM330
Measurement Range	Supported Grid Type	Three-phase, split-phase, single-phase
	Voltage Range L-L (Vac)	172~817
	Voltage Range L-N (Vac)	100~472
	Nominal Frequency (Hz)	50/60
	CT ratio	nA:5A
Communication Parameters	Communication Method	RS485
	Communication Distance (m/ft)	1000/3280
Accuracy Parameters	Voltage/Current	Class 0.5
	Active Energy	Class 0.5
	Reactive Energy	Class 1
General Parameters	Dimensions (WxHxD mm/in)	72x85x72/2.83x3.35x2.83
	Housing	4-module
	Weight (g/lb)	240/0.53
	Mounting Method	DIN rail
	User Interface	4 LEDs, Reset Button
	Power Consumption (W)	≤5
Environmental Parameters	IP Rating	IP20
	Operating Temperature Range (°C/°F)	-30~+70/-22~+158
	Storage Temperature Range (°C/°F)	-30~70/-22~+158
	Relative Humidity (no condensation)	0~95%

technical parameter		GM330
	Max. Operating Altitude (m/ft)	3000/9842
Certification Parameters	Certificates	UL1741/ANSI

### 10.1.2 GM3000

Technical Parameter		GM3000
Application		Three-phase
Voltage	Nominal Voltage	3L+N/400V
	Voltage Range	100V~240V
	Frequency	50Hz/60Hz
Current	Rated Current	CT in: 120A/40mA;
	Current Range	0.48A~120A
Power Consumption		<3W
Data Detection		Voltage/Current/Active Power/Reactive Power/Power Factor/Frequency
Energy Calculation		Active/Reactive Power
Accuracy	Voltage/Current	Class I
	Active	Class I
	Reactive	Class II
Communication		RS485 (Max. Baud Rate 9600/ModBus Protocol/Max. Cable Length 100m)
Display		LED, USB, Reset Button
Device	Dimensions (L x W x H mm)	36 x 85 x 66.5
	Weight (g)	450
	Ingress Protection Rating	IP20(Indoor)
	Mounting Method	Back Panel Mounting
Operating Temperature		-25 ~ +60° C
Storage Temperature		-25 ~ +60° C
Humidity		<95% Non-condensing

Operating Altitude(m)	< 2000m
Safe Service Life (Years)	≥25

### 10.1.3 GMK330

model	GMK330
<b>Measurement Range</b>	
Supported Grid Type	1P2W/3P3W/3P4W
Operating voltage (Vac)*	3P4W: 90~264 L-N 3P3W: 90~264 L-L
Frequency (Hz)	50/60
CT ratio	120A: 40mA 200A: 50mA*
Number of CTs	3
<b>Accuracy Parameters</b>	
voltage/current	Class 0.5
Active Energy	Class 0.5
Reactive Energy	Class 1
<b>Communication Parameters</b>	
Communication Method	RS485
Communication Distance (m)	1000
<b>General Parameters</b>	
Dimensions (W*H*D mm)	72*85*72
Housing	4-module
Weight (g)	240
Mounting Method	DIN rail

<b>model</b>	<b>GMK330</b>
User Interface	4 LEDs, Reset button
Power Consumption (W)	< 5
<b>Environmental Parameters</b>	
IP Rating	IP20
Operating Temperature Range (°C)	-30-+70
Storage Temperature Range (°C)	-30-+70
Relative Humidity (non-condensing)	0-95%
Max. Operating Altitude (m)	3000

\*Supports 1.1 times rated voltage input.

\*The standard CT for the meter has been uniformly changed to the 120A:40mA specification. Meters equipped with the 200A:50mA specification CT will no longer be sold after June 2026.

## 10.2 Smart Dongle Technical Data

### 10.2.1 4G Kit-CN-G21

<b>Product Model</b>	<b>4G Kit-CN-G21</b>
Device Management	
Max. Supported Inverter Quantity	1
Power Parameters	
Input Voltage (V)	5
Power Consumption (W)	≤4
Interface Method	USB

<b>Product Model</b>	<b>4G Kit-CN-G21</b>
<b>Communication Parameters</b>	
4G/3G/2G	LTE-FDD: B1/B3/B5/B8 LTE-TDD: B34/B39/B40/B41
GNSS Positioning	BeiDou, GPS
Bluetooth	Bluetooth V5.0
<b>Mechanical Parameters</b>	
Dimensions (W×H×D mm)	48.3*95.5*32.1
Weight (g)	87
indicator	LED* 2
Mounting Method	Plug and Play
SIM Card Size	Micro sim, 15mm*12mm
<b>Environmental Parameters</b>	
Operating Temperature Range (°C)	-30~+65
Storage Temperature Range (°C)	-40~+70
Relative Humidity	0-100%
IP Rating	IP66
Max. Operating Altitude (m)	4000
<b>Compliance Standards</b>	
Certification	SRRC, CTA

### 10.2.2 4G Kit-CN-G20

<b>Product Model</b>	<b>4G Kit-CN-G20</b>
<b>Device Management</b>	
Max. Supported Inverter Quantity	1
<b>Power Parameters</b>	
Input Voltage (V)	5
Power Consumption (W)	≤4
Interface Type	USB







Product Model	4G Kit-CN-G20
Communication Parameters	
4G/3G/2G	LTE-FDD: B1/B3/B5/B8 LTE-TDD: B34/B39/B40/B41
GNSS Positioning	/
Bluetooth	Bluetooth V5.0
Mechanical Parameters	
Dimensions (W×H×D mm)	48.3*95.5*32.1
Weight (g)	87
indicator	LED* 2
Mounting Method	Plug and Play
SIM Card Size	Micro sim, 15mm*12mm
Environmental Parameters	
Operating Temperature Range (°C)	-30~+65
Storage Temperature Range (°C)	-40~+70
Relative Humidity	0-100%
IP Rating	IP66
Max. Operating Altitude (m)	4000
Compliant Standards	
Certification	SRRC、CTA

### 10.2.3 WiFi/LAN Kit-20

technical parameter		WiFi/LAN Kit-20
Output Voltage (V)		5
Power Consumption (W)		≤2
Communication Interface		USB
Communication Parameters	Ethernet	10M/100Mbps Adaptive
	Wireless	IEEE 802.11 b/g/n @2.4 GHz

technical parameter		WiFi/LAN Kit-20
	Bluetooth	Bluetooth V4.2 BR/EDR and Bluetooth LE Standard
Mechanical Parameters	Dimensions (Width × Height × Thickness mm)	48.3*159.5*32.1
	Weight (g)	82
	Ingress Protection Rating	IP65
	Mounting Method	USB Port Plug and Unplug
Operating Temperature Range (°C)		-30~+60
Storage Temperature Range (°C)		-40~+70
Relative Humidity		0-95%
Max. Operating Altitude (m)		4000

#### 10.2.4 Ezlink3000

indicator /Silk Screen	Color	Status	Description
Power indicator 	Blue		Flashing = The communication stick is operating normally.
			Off = The communication stick is powered off.
Communi cation indicator 	Green		Steady on = The communication stick is connected to the server.
			Double flash = The communication stick is not connected to the router.
			Quadruple flash = The communication stick is connected to the router but not to the server.
RELOAD	-	-	<ul style="list-style-type: none"> <li>• Short press for 1-3 seconds to restart the communication stick.</li> <li>• Long press for 6-10 seconds to restore factory settings.</li> </ul> <p>Double-click quickly to enable Bluetooth signal (only lasts for 5 minutes).</p>

# 11 Appendix

## 11.1 FAQ

### 11.1.1 How to conduct auxiliary detection for smart meters/CT?

The meter detection function can detect whether the meter CT is connected correctly and the current operating status of the meter and CT.

- Method One:

1. Go to **[Home]** > **[Settings]** > **[Meter/CT Auxiliary Detection]** to enter the detection page.
2. Click Start Detection, wait for the detection to complete, and then view the detection results.

- Method Two:

1. Click  > **[System Setup]** > **[Quick Setting]** > **[Meter/CT Assisted Test]** to enter the detection page.
2. Click Start Detection, wait for the detection to complete, and then view the detection results.

### 11.1.2 How to Upgrade the Device Version

Through firmware information, you can view or upgrade:

The inverter's DSP version, ARM version, communication module software version, battery's BMS version, DCDC version, etc.

- **Prompt Upgrade:**

When the user opens the App, an upgrade prompt pops up on the home page. The user can choose whether to upgrade. If they choose to upgrade, they can complete the upgrade by following the on-screen instructions.

- **Regular Upgrade:**

Go to **[Home]** > **[Settings]** > **[Firmware Information]** to access the firmware information view.

Tap "Check for Updates". If a new version is available, complete the upgrade by following the on-screen instructions.

- **Forced Upgrade:**

The App pushes upgrade information. The user must upgrade as prompted; otherwise, the App cannot be used. Complete the upgrade by following the on-screen instructions.

### **Inverter Software Version Upgrade**

- The inverter supports software upgrade via a USB drive.
- Before using a USB drive to upgrade the device, please contact the after-sales service center to obtain the software upgrade package and upgrade method.

## **11.2 Abbreviations**

<b>Abbreviation</b>	<b>English Description</b>	<b>Description in English</b>
Ubatt	Battery Voltage Range	Battery voltage range
Ubatt,r	Nominal Battery Voltage	Nominal battery voltage
Ibatt,max (C/D)	Max. Charging Current Max. Discharging Current	Max. charging/discharging current
EC,R	Rated Energy	Rated energy
UDCmax	Max.Input Voltage	Max. Input Voltage
UMPP	MPPT Operating Voltage Range	MPPT Voltage Range
IDC,max	Max. Input Current per MPPT	Max. input current per MPPT
ISC PV	Max. Short Circuit Current per MPPT	Max. short-circuit current per MPPT
PAC,r	Nominal Output Power	Nominal output power
Sr (to grid)	Nominal Apparent Power Output to Utility Grid	Nominal Apparent Power Output to Utility Grid
Smax (to grid)	Max. Apparent Power Output to Utility Grid	Max. Apparent Power Output to Utility Grid
Sr (from grid)	Nominal Apparent Power from Utility Grid	Nominal apparent power from utility grid
Smax (from grid)	Max. Apparent Power from Utility Grid	Max. apparent power from utility grid

<b>Abbreviation</b>	<b>English Description</b>	<b>Description in English</b>
UAC,r	Nominal Output Voltage	Nominal output voltage
fAC,r	Nominal AC Grid Frequency	Nominal AC Grid Frequency
IAC,max(to grid)	Max. AC Current Output to Utility Grid	Max. AC Current Output to Utility Grid
IAC,max(from grid)	Max. AC Current From Utility Grid	Max. Current from Grid
P.F.	Power Factor	Power Factor
Sr	Back-up Nominal apparent power	Off-grid nominal apparent power
Smax	Max. Output Apparent Power (VA) Max. Output Apparent Power without Grid	Max. Apparent Power to Grid
IAC,max	Max. Output Current	Max. Current to Grid
UAC,r	Nominal Output Voltage	Max. output voltage
fAC,r	Nominal Output Frequency	Nominal output voltage frequency
Toperating	Operating Temperature Range	Operating Temperature Range
IDC,max	Max. Input Current	Max. input current
UDC	Input Voltage	Input voltage
UDC,r	DC Power Supply	DC input
UAC	Power Supply/AC Power Supply	Input voltage range / AC input
UAC,r	Power Supply/Input Voltage Range	Input voltage range / AC input
Toperating	Operating Temperature Range	Operating Temperature Range
Pmax	Max Output Power	Maximum Power
PRF	TX Power	Transmit power
PD	Power Consumption	Power consumption
PAC,r	Power Consumption	Power consumption
F (Hz)	Frequency	Frequency
ISC PV	Max. Input Short Circuit Current	Max. input short-circuit current
Udcmin-Udcmax	Range of input Operating Voltage	Operating Voltage range

<b>Abbreviation</b>	<b>English Description</b>	<b>Description in English</b>
UAC,rang(L-N)	Power Supply Input Voltage	Adapter input voltage range
Usys,max	Max System Voltage	Max. system voltage
Haltitude,max	Max. Operating Altitude	Max. operating altitude
PF	Power Factor	Power Factor
THDi	Total Harmonic Distortion of Current	Current harmonic
THDv	Total Harmonic Distortion of Voltage	Voltage harmonic
C&I	Commercial & Industrial	Commercial & Industrial
SEMS	Smart Energy Management System	Smart Energy Management System
MPPT	Maximum Power Point Tracking	Maximum power point tracking
PID	Potential-Induced Degradation	Potential-induced degradation
Voc	Open-Circuit Voltage	Open-circuit voltage
Anti PID	Anti-PID	Anti-PID
PID Recovery	PID Recovery	PID Recovery
PLC	Power-line Commucation	Power-line communication
Modbus TCP/IP	Modbus Transmission Control / Internet Protocol	Modbus TCP/IP
Modbus RTU	Modbus Remote Terminal Unit	Modbus based on serial link
SCR	Short-Circuit Ratio	Short-circuit ratio
UPS	Uninterruptable Power Supply	Uninterruptible power supply
ECO mode	Economical Mode	Economic Mode
TOU	Time of Use	Time of use
ESS	Energy Stroage System	Energy storage system
PCS	Power Conversion System	Power conversion system
RSD	Rapid shutdown	Rapid Shutdown
EPO	Emergency Power Off	Emergency Poweroff
SPD	Surge Protection Device	Surge protection
ARC	zero injection/zero export Power Limit / Export Power Limit	Power Limit
DRED	Demand Response Enabling Device	Demand response enabling device

Abbreviation	English Description	Description in English
RCR	Ripple Control Receiver	-
AFCI	AFCI	AFCI DC arc protection
GFCI	Ground Fault Circuit Interrupter	Ground fault circuit interrupter
RCMU	Residual Current Monitoring Unit	Residual current monitoring unit
FRT	Fault Ride Through	Fault ride through
HVRT	High Voltage Ride Through	High voltage ride through
LVRT	Low Voltage Ride Through	Low voltage ride through
EMS	Energy Management System	Energy management system
BMS	Battery Management System	Battery management system
BMU	Battery Measure Unit	Battery measure unit
BCU	Battery Control Unit	Battery control unit
SOC	State of Charge	State of charge
SOH	State of Health	State of health
SOE	State Of Energy	State of energy
SOP	State Of Power	State of power
SOF	State Of Function	State of function
SOS	State Of Safety	State of safety
DOD	Depth of discharge	Depth of discharge

## 11.3 Explanation of Terms

- **Explanation of Overvoltage Categories**
  - **Overvoltage Category I:** Equipment connected to circuits which have measures to limit transient overvoltages to a very low level.
  - **Overvoltage Category II:** Energy-consuming equipment supplied from a fixed electrical installation. This category includes appliances, portable tools, and other household and similar loads. If special requirements for reliability and suitability apply to such equipment, Overvoltage Category III shall be used.
  - **Overvoltage Category III:** Equipment in fixed electrical installations where special requirements for reliability and suitability must be met. This includes switching devices in fixed installations and industrial equipment permanently connected to fixed electrical installations.
  - **Overvoltage Category IV:** Equipment used at the origin of the electrical installation, including electricity meters and primary overcurrent protection devices.

- **Explanation of Damp Location Categories**

Environmental Parameters	Grade		
	3K3	4K2	4K4H
Temperature Range	0~+40°C	-33~+40°C	-33~+40°C
Humidity Range	5% to 85%	15% to 100%	4% to 100%

- **Explanation of Environmental Categories:**

- **Outdoor Inverter:** Ambient air temperature range from -25°C to +60°C, suitable for Pollution Degree 3 environments.
- **Indoor Type II Inverter:** Ambient air temperature range from -25°C to +40°C, suitable for Pollution Degree 3 environments.
- **Indoor Type I Inverter:** Ambient air temperature range from 0°C to +40°C, suitable for Pollution Degree 2 environments.

- **Explanation of Pollution Degree Categories**

- **Pollution Degree 1:** No pollution or only dry, non-conductive pollution.
- **Pollution Degree 2:** Normally only non-conductive pollution occurs. Temporary conductivity caused by condensation must be expected.
- **Pollution Degree 3:** Conductive pollution occurs, or dry non-conductive pollution becomes conductive due to condensation.
- **Pollution Degree 4:** Persistent conductivity occurs, for example due to conductive dust, rain, or snow.

## 11.4 Battery SN Code Meaning

\*\*\*\*\*2388\*\*\*\*\*  
  
 11-14位

LXD10DSC0002

The 11th to 14th digits of the product SN code are the production time code.  
 The production date in the above image is 2023-08-08

- The 11th and 12th digits are the last two digits of the production year, e.g., 2023 is represented as 23;
- The 13th digit is the production month, e.g., August is represented as 8;  
Details are as follows:

Month	Jan-Sep	October	November	December
Month Code	1~9	A	B	C

- The 14th digit is the production date, e.g., the 8th day is represented as 8;  
Numbers are used preferentially, e.g., 1~9 represent the 1st to 9th days, A represents the 10th day, and so on. Among them, the letters I and O are not used to avoid confusion. Details are as follows:

Production Date	1	2	3	4	5	6	7	8	9
Code	1	2	3	4	5	6	7	8	9

Production Date	10	11	12	13	14	15	16	17	18
Code	A	B	C	D	E	F	G	H	J

Production Date	21	22	23	24	25	26	27	28	29
Code	M	N	P	Q	R	S	T	U	V

## 11.5 Safety Country

No.	Safety Code	No.	Safety Code
Europe			
1	IT-CEI 0-21	43	CZ-C
2	IT-CEI 0-16	44	CZ-D
3	DE LV with PV	45	RO-A
4	DE LV without PV	46	RO-B
5	DE-MV	47	RO-D
6	ES-A	48	GB-G98
7	ES-B	49	GB-G99-A

No.	Safety Code	No.	Safety Code
8	ES-C	50	GB-G99-B
9	ES-D	51	GB-G99-C
10	ES-island	52	GB-G99-D
11	BE	53	NI-G98
12	FR	54	IE-16/25A
13	FR-island-50Hz	55	IE-72A
14	FR-island-60Hz	56	IE-ESB
15	PL-A	57	IE-EirGrid
16	PL-B	58	PT-D
17	PL-C	59	EE
18	PL-D	60	NO
19	NL-16/20A	61	FI-A
20	NL-A	62	FI-B
21	NL-B	63	FI-C
22	NL-C	64	FI-D
23	NL-D	65	UA-A1
24	SE-A	66	UA-A2
25	SE MV	67	EN 50549-1
26	SK-A	68	EN 50549-2
27	SK-B	69	DK-West-B-MVHV
28	SK-C	70	DK-East-B-MVHV
29	HU	71	DK-West-C-MVHV
30	CH	72	DK-East-C-MVHV
31	CY	73	DK-West-D-MVHV
32	GR	74	DK-East-D-MVHV
33	DK-West-A	75	FR-Reunion
34	DK-East-A	76	BE-LV (>30kVA)
35	DK-West-B	77	BE-HV
36	DK-East-B	78	CH-B
37	AT-A	79	NI-G99-A
38	AT-B	80	NI-G99-B

No.	Safety Code	No.	Safety Code
39	BG	81	NI-G99-C
40	CZ-A-09	82	NI-G99-D
41	CZ-B1-09	83	IE-LV
42	CZ-B2-09	84	IE-MV
<b>Globe</b>			
1	60Hz-Default	5	IEC 61727-50Hz
2	50Hz-Default	6	IEC 61727-60Hz
3	127Vac-60Hz-Default	7	Warehouse
4	127Vac-50Hz-Default		
<b>America</b>			
1	Argtina	30	US-ISO-NE-480Vac
2	US-208Vac	31	US-ISO-NE-208Vac-3P
3	US-240Vac	32	US-ISO-NE-220Vac-3P
4	Mexico-220Vac	33	US-ISO-NE-240Vac-3P
5	Mexico-440Vac	34	PR-208Vac
6	US-480Vac	35	PR-240Vac
7	US-208Vac-3P	36	PR-480 Vac
8	US-220Vac-3P	37	PR-208Vac-3P
9	US-240Vac-3P	38	PR-220Vac-3P
10	US-CA-208Vac	39	PR-240Vac-3P
11	US-CA-240Vac	40	Cayman
12	US-CA-480Vac	41	Brazil-220Vac
13	US-CA-208Vac-3P	42	Brazil-208Vac
14	US-CA-220Vac-3P	43	Brazil-230Vac
15	US-CA-240Vac-3P	44	Brazil-240Vac
16	US-HI-208Vac	45	Brazil-254Vac
17	US-HI-240Vac	46	Brazil-127Vac
18	US-HI-480Vac	47	Brazil-ONS
19	US-HI-208Vac-3P	48	Barbados
20	US-HI-220Vac-3P	49	Chile-BT
21	US-HI-240Vac-3P	50	Chile-MT

No.	Safety Code	No.	Safety Code
22	US-Kauai-208Vac	51	Colombia
23	US-Kauai-240Vac	52	Colombia<0.25MW 1P
24	US-Kauai-480Vac	53	Colombia<0.25MW 3P
25	US-Kauai-208Vac-3P	54	IEEE 1547-208Vac
26	US-Kauai-220Vac-3P	55	IEEE 1547-20Vac
27	US-Kauai-240Vac-3P	56	IEEE 1547-240Vac
28	US-ISO-NE-208Vac	57	IEEE 1547-230/400Vac
29	US-ISO-NE-240Vac		
Oceania			
1	Australia-A	4	Newzealand
2	Australia-B	5	Newzealand:2015
3	Australia-C	6	NZ-GreGrid
Asia			
1	China A	25	JP-420Vac-50Hz
2	China B	26	JP-420Vac-60Hz
3	China's high pressure	27	JP-480Vac-50Hz
4	China's highest pressure	28	JP-480Vac-60Hz
5	China Power Station	29	Sri Lanka
6	China 242 Shandong	30	Singapore
7	China 242 Hebei	31	Israel-OG
8	China PCS	32	Israel-LV
9	Taiwan	33	Israel-MV
10	Hongkong	34	Israel-HV
11	China 242 Northeast	35	Vietnam
12	Thailand-MEA	36	Malaysia-LV
13	Thailand-PEA	37	Malaysia-MV
14	Mauritius	38	DEWA-LV
15	Korea	39	DEWA-MV
16	India	40	Saudi Arabia
17	India-CEA	41	JP-690Vac-50Hz

No.	Safety Code	No.	Safety Code
18	Pakistan	42	JP-690Vac-60Hz
19	Philippines	43	Srilanka
20	Philippines-127Vac	44	IEC 61727-127Vac-50Hz
21	JP-50Hz	45	IEC 61727-127Vac-60Hz
22	JP-60Hz	46	JP-550Vac-50Hz
23	JP-440Vac-50Hz	47	JP-550Vac-60Hz
24	JP-440Vac-60Hz	48	India-Higher
Africa			
1	South Africa-LV	4	Ghana
2	South Africa-B-MV	5	Ghana-HV
3	South Africa-C-MV		

# Contact Information

GoodWe Technologies Co., Ltd.  
No. 90 Zijin Road, Suzhou New District, China  
400-998-1212  
[www.goodwe.com](http://www.goodwe.com)  
[service@goodwe.com](mailto:service@goodwe.com)